

Digital electropneumatic Positioner SideControl



Type 8792 can be combined with...



Yoke type actuators



Rotary actuators

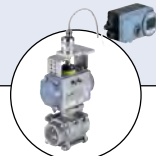

Rotary actuators with remote positioner

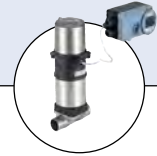

Process control valve with remote positioner

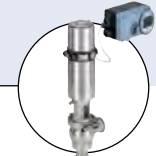

Hygienic process control valve with remote positioner

- Compact and robust design
- Easy to start using Tune function
- Integrated diagnostic functions for valve monitoring
- Dynamic positioning system with no air consumption in controlled state
- PROFIBUS DP-V1, DeviceNet, EtherNet/IP, PROFINET, Modbus TCP or büS (Bürkert System Bus)

The robust and compact positioner is designed to standardisation acc. to IEC 60534-6-1 or VDI/VDE 3845 (IEC 60534-6-2) for assembly with linear and rotary actuators. In addition, the remote version with the displacement position sensor can be combined with Bürkert process control valves. The digital electropneumatic positioner SideControl can be operated with the usual current and voltage standard signals and can also be equipped with the fieldbus interface. The Positioner is equipped with additional diagnostic functions to monitor the state of the valve. Through status signals, valve diagnostic messages are transmitted according to NAMUR NE 107 recommendations and recorded as history. With the diagnosis, the operating conditions of the control valve can be monitored. This allows planned maintenance and optimises plant availability. Operation occurs via the external operation and display module with a backlit graphical display. The user operation is very simple and clear, identical to the Bürkert positioner or process controller TopControl, Type 8692/8693. The pilot valve system can be used equally for single and double-acting actuators. It is characterised by a defined safety feature in case of failure of the electrical or pneumatic power supply and possesses an enormous air capacity range with pressure supply up to 7 bar.

Technical data	
Material	
Body	Aluminium plastic-coated
Seal	EPDM, NBR, FKM
Operating voltages	24 V DC \pm 10 %
Residual ripple	Max. 10 %
Setpoint setting	0/4 ... 20 mA and 0 ... 5/10 V
Input resistance	0/4 ... 20 mA: 180 Ω 0 ... 5/10 V: 19 k Ω
Analogue feedback	4 ... 20 mA, 0 ... 20 mA 0 ... 10 V, 0 ... 5 V
Binary input	Galvanically isolated, 0 ... 5 V = log "0", 10 ... 30 V = log "1"
Binary output	2 Outputs (optional), galvanically separated
Current limit	100 mA, Output will be synchronised when overloaded
Control medium	neutral gases, air, quality classes acc. to ISO 8573-1
Dust concentration	Class 7 (< 40 μ m particle size)
Particle density	Class 5 (< 10 mg/m ³)
Pressure condensation point	Class 3 (< -20 °C)
Oil concentration	Class X (< 25 mg/m ³)
Ambient temperature	-10 to +60 °C (without Ex-Approval) 0 to +60 °C (with ATEX / IECEx-Approval)
Pilot air ports	Threaded ports G 1/4
Supply pressure	1.4 ... 7 bar ^{1) 2)}
Air supply filter	Exchangeable (aperture size ~0,1 mm)
Actuator system	
Air capacity	Single and double-acting to 150 l _v /min, 50 l _v /min (with 1.4 bar ²⁾) for aeration and ventilation 150 l _v /min (with 6 bar ²⁾) for aeration and ventilation (Q _{min} = 100 l _v /min (acc. to the definition with decrease in pressure from 7 ... 6 bar absolute)
Position detection module	Potentiometer, max. angle 180°
Stroke range valve spindle	Min. 30° on the rotary shaft, depending on lever
Installation	As required, display above or sideways

¹⁾ The supply pressure has to be 0.5 ... 1 bar above the minimum required pilot pressure for the valve actuator

²⁾ Pressure specifications: Overpressure with respect to atmospheric pressure

continued on next page

Technical data, continued

Technical data	
Type of protection	IP65/IP67 acc. to EN 60529, Type 4X acc. to NEMA 250 standard
Power consumption	< 5 W
Electrical connection	M12, 8 pin/4 pin; M8, 4 pin
Multipole connection	2x M20 x 1,5 (cable Ø 6... 12 mm) on screw terminals (0.14... 1.5 mm ²)
Cable gland	1x M12 x 1,5 (cable Ø 3... 6.5 mm)
Remote version	
Bus communication	PROFIBUS DP-V1, DeviceNet, EtherNet/IP, PROFINET, Modbus TCP or bÜS (based on CANopen)
Protection class	III acc. to DIN EN 61140
Conformity	EMC directive 2014/30/EU
CSA approval information	
Product category code	Class 3221 82-VALVES - Actuators - Certified to US standards Class 3221 02-VALVES - Actuators
Considered standards	CAN/CSA-C22 2 No. 139 UL 429
CSA trademark	
Ex-Approval	ATEX $\text{Ex ec ic IIC T4 Gc} / \text{Ex tc IIIC T135 } ^\circ\text{C Dc}$ Certificate; BVS 16 ATEX E 118 X
	IECEX $\text{Ex ec ic IIC T4 Gc} / \text{Ex tc IIIC T135 } ^\circ\text{C Dc}$ Certificate; IECEX BVS 16.0091 X

Technical data - Linear Remote Position Sensor (ELEMENT)	
Electrical connection	
Cable gland	1x M16 x 1,5 (cable Ø 5... 10 mm) on terminal screws (0.14... 1.5 mm ²)
Connection cable length	10 m
Operating voltage	24 V DC \pm 10 %
Power consumption	< 0.3 W
Sensor measurement range	3... 45 mm (Stroke range valve spindle)
Actual position signal	digital (RS485)
Ambient temperature	-25 to +80 °C
Protection class	III acc. to DIN EN 61140
Type of protection	IP65 and IP67 acc. to EN 60529, Type 4X acc. to NEMA 250 standard
Type of Ignition protection	II 3D Ex tc IIIC T135 °C Dc II 3G Ex nA IIC T4 Gc
Conformity	EMC directive 2014/30/EU
Approvals	cULus Certificate no. 238179

Technical data - rotative Remote Position Sensor (NAMUR)	
Electrical connection	2 m round cable (shielded)
Operating voltage	10... 30 V DC
Residual ripple	< 0.8 W
Sensor measurement range	0° to 360°
Actual position signal	digital (RS485)
Ambient temperature	-25 to +80 °C
Protection class	III acc. to DIN EN 61140
Type of protection	IP65 acc. to EN 60529
Conformity	EMC directive 2014/30/EU
Approvals	UL (cULus) Certificate no. E226909

Technical data - Position feedback with proximity switches (Accessory)	
Electrical connection	M12, 4 pin
Output function	3-wire, normally open contact, PNP
Operating voltage	10... 30 V DC
Residual ripple	\leq 10 % U _{ss}
DC rated current	\leq 100 mA
Type of protection	IP65 and IP67
Protection class	III acc. to DIN EN 61140
Conformity	EMC directive 2014/30/EU
Approvals	cCSAus

Note: The position feedback has two proximity switches which are independently adjustable via switch lugs.

Using a remote positioner the length of the control air pipes influences the dynamics and attainable accuracy of the position control loop. The length of the control air pipes therefore should be as short as possible.

Example of assembly variations of positioner SideControl

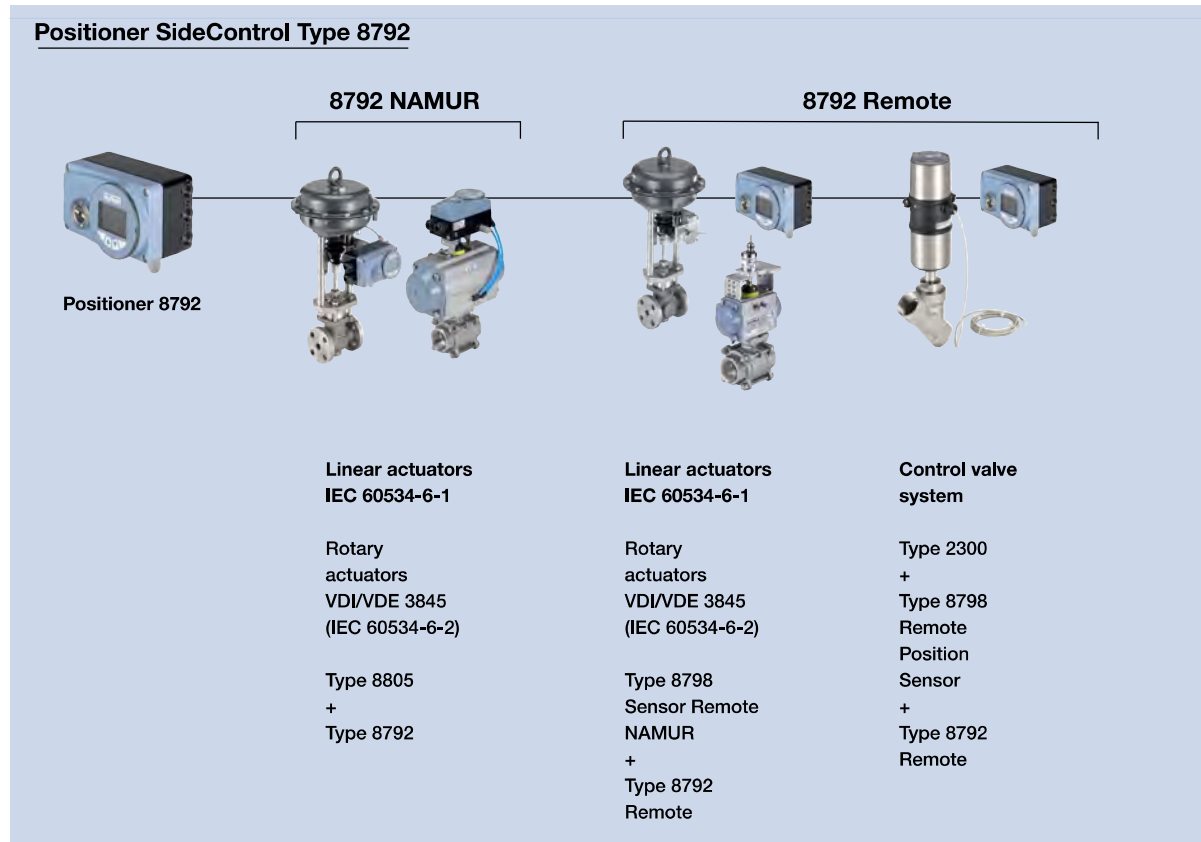

DTS 1000121137 EN Version: T Status: RL (released | freigegeben | validé) printed: 21.11.2018

Assembly options

NAMUR Version

(Positioner with integrated position sensor, assembly acc. to NAMUR/IEC 60534-6-1 and VDI/VDE 3845 (IEC 60534-6-2))

Assembly on linear actuator



Description	Article no.
Adapter kit	787215

Assembly on rotary actuator



Description	Article no.
Adapter kit	787338
Assembly bridge	770294

Dimensions [mm]

Adapter kit

Assembly bridge

Actuator shaft height	A	B	C
20	46,5	80	-
30	56,5	80	130
50	76,5	-	130

Position feedback with proximity switches

(upgrade feature for SideControl NAMUR)

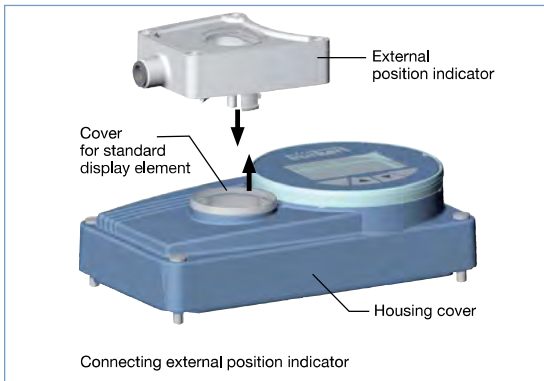

Description	Article no.
Position feedback	677218

DTS 1000121137 EN Version: T Status: RL (released | freigegeben | validé) printed: 21.11.2018

Assembly options *continued*

Remote version

(Displaced positioner with external remote position sensor)

Assembly with accessory brackets



Description	Article no.
Assembly bracket for wall mounting	675715 

Dimensions [mm]

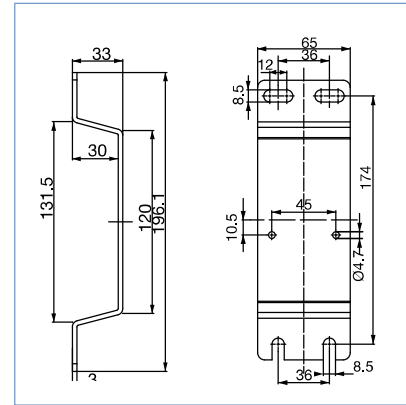

Assembly on DIN-Rail

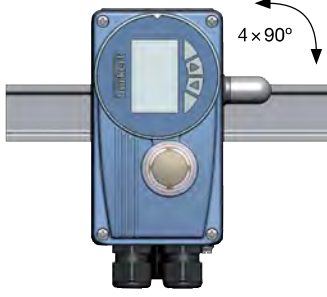

The adapter can be turned every 90° on the DIN-Rail

4 × 90°

Description	Article no.
DIN rail assembly kit	675702 

Dimensions [mm]

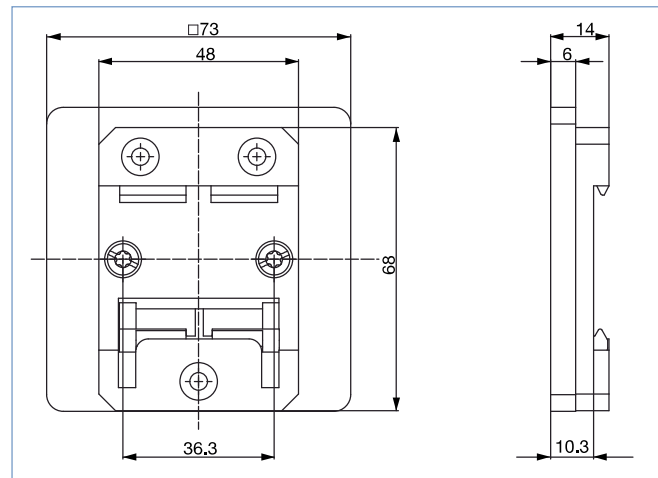

Assembly options *continued*

Remote version

(Remote position sensor for displaced positioner)

Type 8798



Description	Article no.	
	Standard	ATEX II 3 GD
Remote Position Sensor		
Mounting on control valves Type 23xx	212360	226860
Mounting on control valves Type 27xx	211535	226859

Description	Article no.
Remote Position Sensor NAMUR	211536

Dimensions

For mounting on Control valves ELEMENT Types 23xx

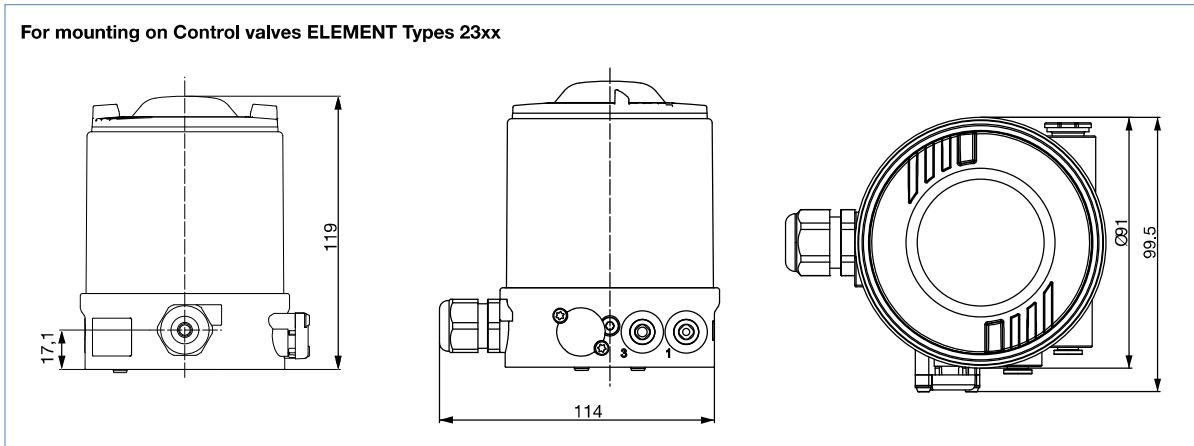

Dimensions

Mounting on control valves according to NAMUR (IEC 60534-6-1 / VDI/VDE 3845 (IEC 60534-6-2))

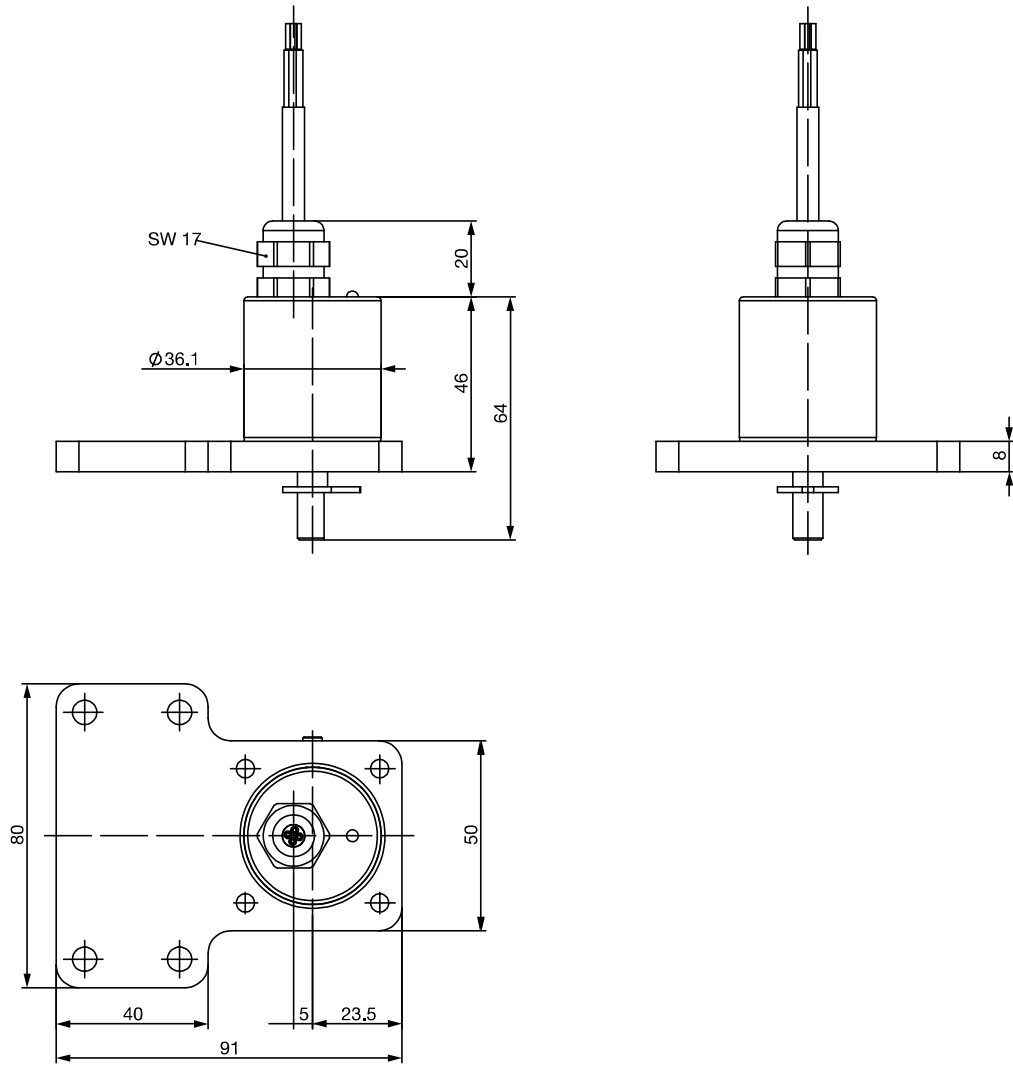

Ordering Chart (further version on request)

Positioner SideControl Type 8792 NAMUR version

NAMUR IEC 60534-6-1 VDI/VDE 3845 (IEC 60534-6-2)

Communication	Electrical connection	Analogue feedback	2 Binary outputs	Diagnostic functions ¹⁾	cCSAus	ATEX II 3 GD / IECEx	Article no.
Single and double-acting, universal air capacity							
without fieldbus communication	Cable gland	no	no		yes		206610
		no	yes	yes	yes		206612
		yes	yes	yes	yes		206611
		yes	yes	yes	yes	yes	310306
	Multipole	no	no			yes	206613
		no	yes	yes	yes		206615
		yes	yes	yes	yes		206614
		yes	yes	yes	yes	yes	206616
PROFIBUS DP-V1	Multipole	via Bus	no		yes		310308
		via Bus	no			yes	310309
		via Bus	yes	yes		yes	206617
		via Bus	yes	yes	yes		239094
DeviceNet	Multipole	no	no		yes		239095
		no	yes	yes		yes	317932
EtherNet/IP	Multipole	via Bus	no	yes			317933
		via Bus	yes	yes			317938
		via Bus	no	yes		yes	317939
		via Bus	yes	yes		yes	317942
PROFINET	Multipole	via Bus	no	yes			317943
		via Bus	yes	yes			317948
		via Bus	no	yes		yes	317949
		via Bus	yes	yes		yes	317952
Modbus TCP	Multipole	via Bus	no	yes			317953
		via Bus	yes	yes			317958
		via Bus	no	yes		yes	317959
		via Bus	yes	yes		yes	317962
bÜS - Bürkert System Bus	Multipole	via Bus	no	yes			317963
		via Bus	yes	yes			317968
		via Bus	no	yes		yes	317969
		via Bus	yes	yes		yes	317969

Positioner SideControl Type 8792 remote version

Communication	Electrical connection	Analogue feedback	2 Binary outputs	Diagnostic functions ¹⁾	cCSAus	ATEX II 3 GD / IECEx	Article no.
Single-acting with low air capacity for actuator series Type 23xx (Ø 70/90 mm)							
without fieldbus communication	Cable gland	yes	yes	yes	yes		224870
		no	yes	yes	yes		224871
EtherNet/IP	Multipole	via Bus	yes	yes			317936
PROFINET		via Bus	yes	yes			317946
Modbus TCP		via Bus	yes	yes			317956
bÜS - Bürkert System Bus		via Bus	yes	yes			317966
Single and double-acting with universal air capacity for actuator series Type 23xx (Ø 130 mm) and 27xx (Ø 175/225 mm)							
without fieldbus communication	Cable gland	no	no		yes		206623
		yes	yes	yes	yes		206624
		no	yes	yes	yes		206625
		yes	yes	yes	yes	yes	310310
EtherNet/IP	Multipole	via Bus	yes	yes			317935
PROFINET		via Bus	yes	yes			317945
Modbus TCP		via Bus	yes	yes			317955
bÜS - Bürkert System Bus		via Bus	yes	yes			317965

¹⁾ see additional software functions parametrisable diagnostic functions on page 13**Note:** cCSAus approval in preparation for device versions with EtherNet/IP, PROFINET, Modbus TCP and bÜS

Ordering Chart, continued

Remote Position Sensor for SideControl Type 8792 remote version

Assembly variations	Electrical connection	cULus	ATEX II 3 GD / IECEx	Article no.
Control valve Type 23xx	Cable gland - 10 m round cable	yes	no	212360
	Cable gland - 10 m round cable	no	yes	226860
Control valve Type 27xx	Cable gland - 10 m round cable	yes	no	211535
	Cable gland - 10 m round cable	no	yes	226859
NAMUR (rotative)	Cable gland - 2 m round cable (max. extension 10 m)	yes	no	211536

Ordering chart for accessories

Description	Article no.
Accessories for SideControl NAMUR	
Assembly bridge VDI/VDE 3845 (IEC 60534-6-2), stainless steel	770294
Adapter kit VDI/VDE 3845 (IEC 60534-6-2), stainless steel	787338
Adapter kit linear actuators IEC 60534-6-1, stainless steel	787215
Position feedback with proximity switches (optional upgrade feature) ¹⁾	677218

Accessories for SideControl Remote	
Bracket for wall mounting, stainless steel	675715
DIN rail assembly kit, Aluminium/stainless steel	675702
Adapter kit - remote sensor control valves Type 23xx Actuator size Ø 70/90/130 mm	679917
Adapter kit - remote sensor control valves Type 27xx Actuator size Ø 175 / 225 mm	679945
Sensor Puck (replacement part)	682240

Standard Accessories	
M12 socket 8 pin with 5 m cable for power supply and input/output signals	919267
M8 plug 4 pin for binary outputs, with solder joints	917131
USB bÜS-Interface Set (bÜS-Stick + connection cable with M12 plug + connection cable M12 on micro USB for the bÜS service interface) to connect with PC-Tool Bürkert Communicator (only for device versions with EtherNet/IP, PROFINET, Modbus TCP and bÜS - Bürkert System Bus)	772551
bÜS cable extension M12, length 1 m	772404
bÜS cable extension M12, length 3 m	772405
bÜS cable extension M12, length 5 m	772406
bÜS cable extension M12, length 10 m	772407
SIM card	291773
Silencer G ¼" (replacement part)	780780
Sensor puck (replacement part)	682240
USB interface for serial communication (only for device versions with PROFIBUS / DeviceNet or without fieldbus communication)	227093
Software Bürkert Communicator	http://www.buerkert.de/de/type/8920

* Related Communication software can be downloaded from www.buerkert.com (8792)

¹⁾ External end position feedback for upgrading SideControl NAMUR

Connection options

Multi-pin connection

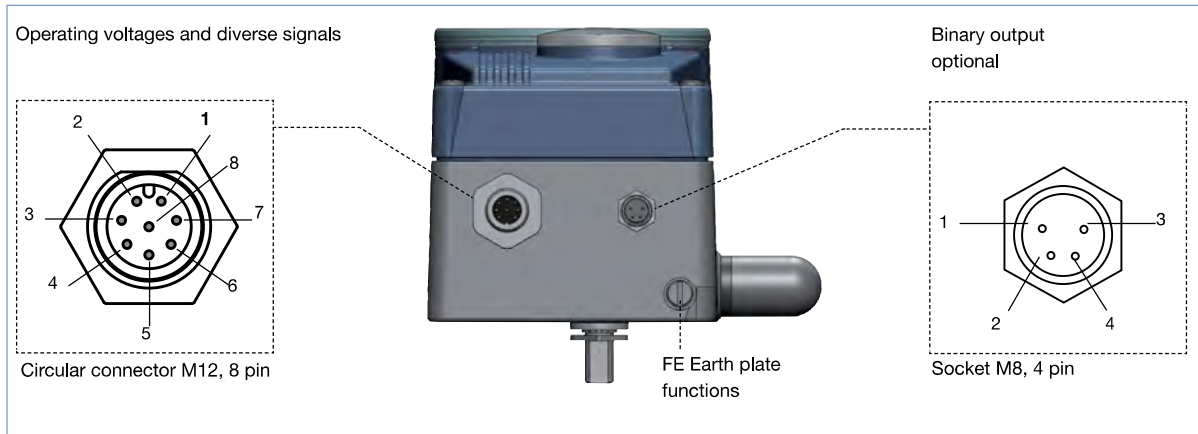

Circular connector M12, 8 pin (Setpoint)

Pin	Configuration	External Circuitry / signal level
1	Setpoint + (0/4 ... 20 mA or 0 ... 5/10 V)	1 + (4 ... 20 mA or 0 ... 10 V) Complete galvanically separated
2	Setpoint GND	2 GND
3	GND	3 24 V DC ± 10 % Max. Residual ripple 10 %
4	+24 V	4 24 V DC ± 10 % Max. Residual ripple 10 %
5	Binary input +	5 + 0 ... 5 V (log. 0) 10 ... 30 V (log. 1)
6	Binary input GND	6 GND

Optional analogue feedback

8	Analogue feedback +	8 + (0/4 ... 20 mA or 0 ... 5/10 V,) Complete galvanically separated
7	Analogue feedback GND	7 GND

Socket M8, 4 pin (only with Binary Output Option)

Pin	Configuration	External Circuitry / signal level
1	Binary Output 1	1 24 V / 0 V, NC / NO relative to operating voltage GND (terminal GND)
2	Binary Output 2	2 24 V / 0 V, NC / NO relative to operating voltage GND (terminal GND)
3	Binary Output GND	3 GND

Electrical connection Position feedback with proximity switches (accessory for upgrading)

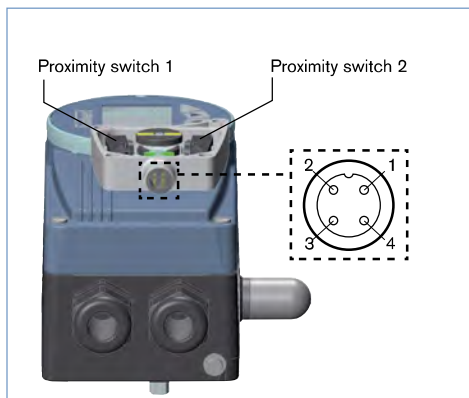

Pin	Config.	External circuit / signal level
1	Supply 10 ... 30 V	+ 10 V ... +30 V 1 10 ... 30 V
2	Switching output (NO) Proximity switch 1	+ 10 V ... +30 V 2 Open / 10 ... 30 V
3	GND	GND 3 GND
4	Switching output (NO) Proximity switch 2	+ 10 V ... +30 V 4 Open / 10 ... 30 V

Connection options, continued

Cable gland connection

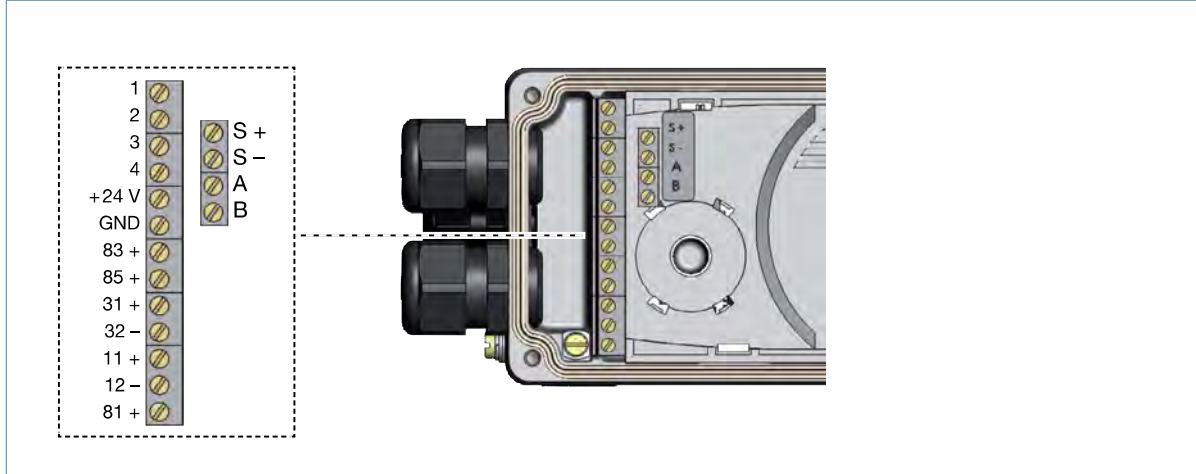

Terminal	Configuration	External Circuitry / signal level
11 +	Setpoint +	11 + + (4 ... 20 mA or 0 ... 10 V) Complete galvanically separated
12 -	Setpoint GND	12 - GND
81 +	Binary input +	81 + + $\begin{cases} 05 \text{ V (log. 0)} \\ 10 \text{ V (log. 1)} \end{cases}$ Obtained at GND operating voltages (GND clamps)
+24 V	Operating voltages +	+24 V 24 V DC $\pm 10\%$
GND	Operating voltages GND	GND max. Residual ripple 10%

Terminals 1, 2, 3, 4: not connected

Optional Analogue feedback / Binary Output

Terminal	Configuration	External Circuitry / signal level
83 +	Binary Output 1	83 + 24 V / 0 V, NC / NO Obtained at GND operating voltages (GND clamps)
85 +	Binary Output 2	85 + 24 V / 0 V, NC / NO Obtained at GND operating voltages (GND clamps)
31 +	Analogue feedback +	31 + \rightarrow + (0/4 ... 20 mA or 0 ... 5/10 V) Complete galvanically separated
32 -	Analogue feedback GND	32 - \rightarrow GND

Terminal 1, 2, 3, 4 : NC

Optional remote version in connection with remote positioner sensor Type 8798

Terminal	Configuration	External Circuitry / signal level
Remote Sensor	A	Serial interface, A cable
	B	Serial interface, B cable
	S +	Supply sensor +
	S -	Supply sensor -
A		A A line
B		B B line
S +		S + +
S -		S - -

For version without remote version: terminals A, B, +, - not connected

Remote sensor Type 8798

Terminal	Wire colour for cable type		Configuration	External Circuitry
	1	2		
1	white	black	Supply Sensor -	1 8791 or
2	brown		Supply Sensor +	2 8792 / 8793
3	yellow	orange	Serial Interface, B line	3 8791 or
4	green	red	Serial Interface, A line	4 8792 / 8793

Terminal 1, 2, 3, 4 : NC

Connection options, continued

Connection PROFIBUS DP

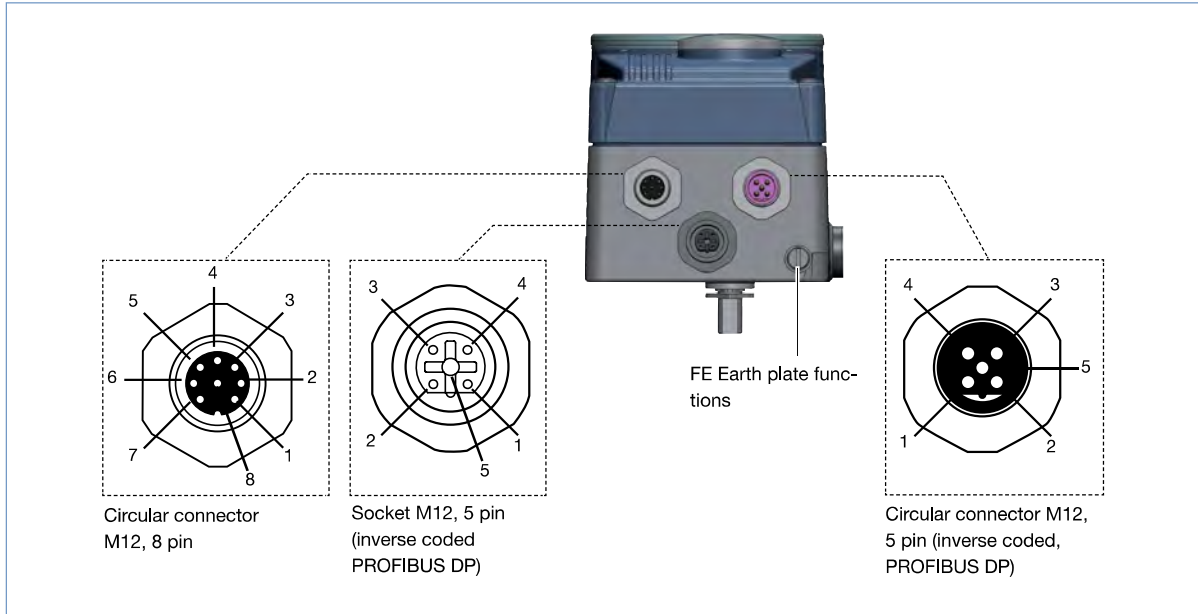

Operating voltage - circular connector M12, 8 pin

Pin	Configuration	External Circuitry / signal level
1	Not configured	
2	Not configured	
3	GND	24 V DC ± 10 % max. Residual ripple 10 %
4	+ 24 V	
5	Binary input +	
6	Binary input -	
7	Binary Output 1 (oriented at Pin 3)	
8	Binary Output 2 (oriented at Pin 3)	

Fieldbus connection - socket/circular connector M12, 5 pin

Pin	Configuration	External Circuitry / signal level
1	VP+ 5	Load resistance supply
2	RxD/TxD-N	Receive and send information -N, A Circuitry
3	DGND	Information transfer potential (measured to 5 V)
4	RxD/TxD-P	Receive and send information -P, B Circuitry
5	Shield	Shield / protective earth

Fieldbus connection DeviceNet - M12, 5 pin circular connector

Pin	Signal	Colour	Configuration
1	Shielding	Not used	
2	V+	Not used	
3	V-	Not used	
4	CAN H	White	
5	CAN L	Blue	

DTS 1000121137 EN Version: T Status: RL (released | freigegeben | validé) printed: 21.11.2018

EtherNet/IP, PROFINET, Modbus TCP connection

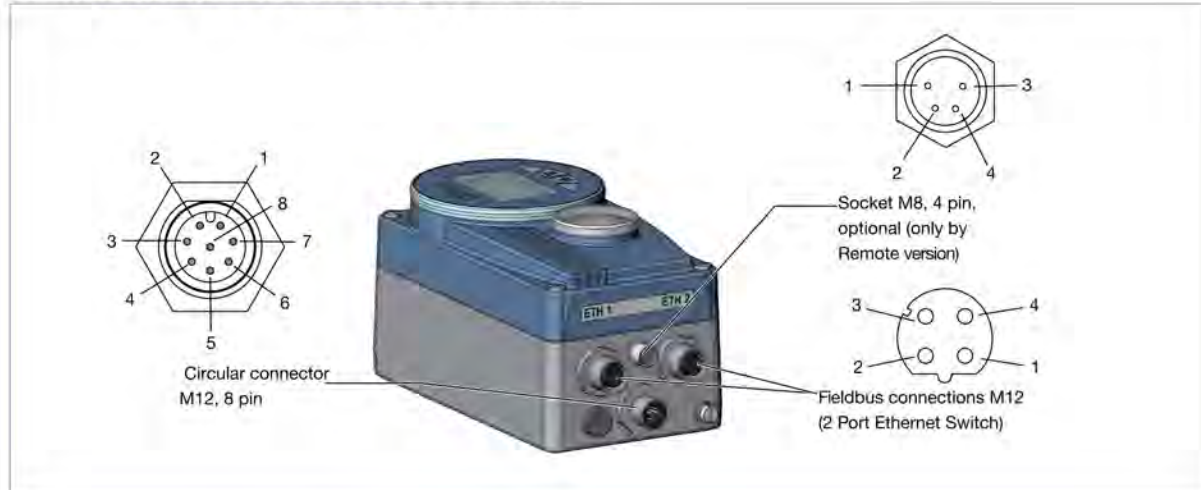

Fieldbus connections M12 D-coded

Connections for EtherNet/IP takes place over circular connector M12, 4 pin D-coded

	Pin 1	Transmit +
	Pin 2	Receive +
	Pin 3	Transmit -
	Pin 4	Receive -

Operating system - circular connector M12, 8 pin

Pin	Configuration	Device side	External circuitry / signal level
1	not allocated		
2	not allocated		
Operating voltage			
3	GND		24 V DC ± 10 % max. residual ripple 10%
4	+ 24 V		
Input signals (e.g. SPS)			
5	Binary input +		0...5 V (log.0) 10...30 V (log.1)
6	Binary input -		
		6	GND (identical to pin 3)
Output signal (e.g. SPS) - (Only used for binary output option)			
7	Binary output 1 (correlated to pin 3)	7	0...24 V
8	Binary output 2 (correlated to pin 3)	8	0...24 V

Connection of the digital, non-contact displacement transducer, Type 8798

Pin	Configuration	Device side	External circuitry
1	Sensor power supply +	S +	
2	Sensor power supply -	S -	
3	Serial interface, A-line	A	
4	Serial interface, B-line	B	

DTS: 1000121137 EN Version: T Status: RL (released | freigegeben | validé) printed: 21.11.2018

Anschluss büS (Bürkert System Bus)

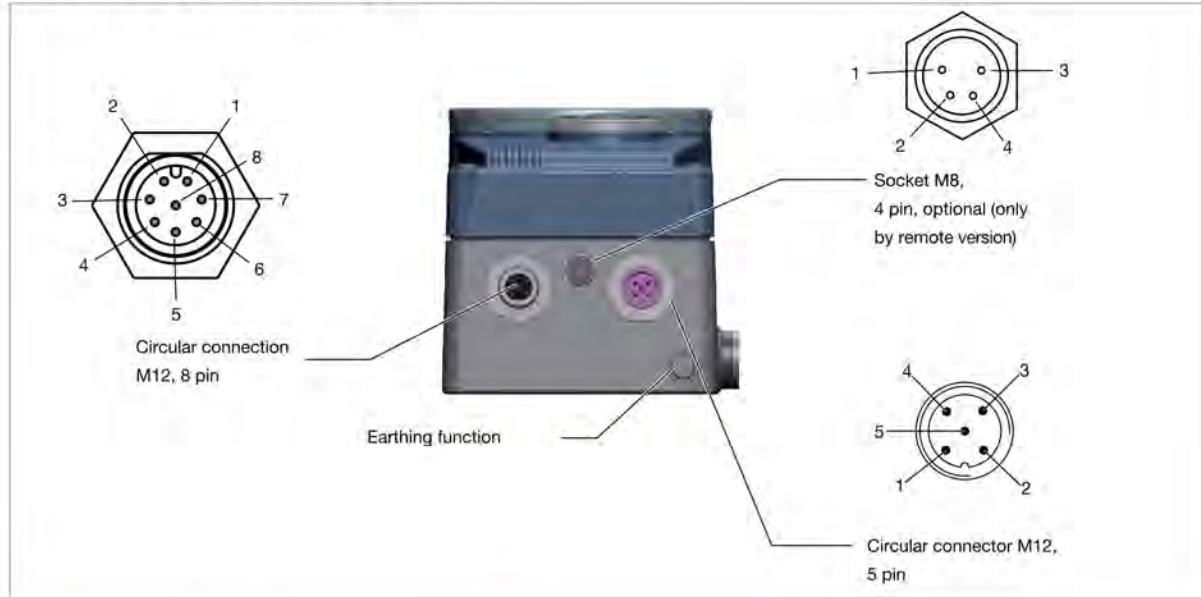

Fieldbus connection- circular connection M12x1, 5 pin

Pin	Wire colour	Configuration
1	CAN-Schild / Shielding	CAN-Schild / Shielding
2	not allocated	
3	Black	Black GND / CAN_GND
4	White	White CAN_H
5	Blue	Blue CAN_L

Operating voltage - circular connections M12, 8 pin

Pin	Configuration	Device side	External circuitry / signal level
1	not allocated		
2	not allocated		
Operating voltage			
3	GND		24 V DC ± 10 % max. residual ripple 10%
4	+ 24 V		
Input signal (e.g. SPS)			
5	Binary input +		0...5 V (log.0) 10...30 V (log.1)
6	Binary input -		
Output signal (e.g. SPS) - (Nur belegt bei Option Binärausgang)			
7	Binary output 1 (correlated to pin 3)		0...24 V
8	Binary output 2 (correlated to pin 3)		0...24 V

DTS 1000121137 EN Version: T Status: RL (released | freigegeben | validé) printed: 21.11.2018

Connection of digital remote position sensor Type 8798 - Socket M8, 4 pin (optional)

Pin	Configuration	Device side	External circuitry
1	Sensor power supply +	S +	
2	Sensor power supply -	S -	
3	Serial interface, A-line	A	
4	Serial interface, B-line	B	

Connection of analogue remote position sensor - Socket M8, 4 pin (optional)

Pin	Configuration	Device side	External circuitry
1	Potentiometer 1	1	
2	Sliding contact 2	2	
3	Potentiometer 3	3	
4	not allocated		

DTS 1000121137 EN Version: T Status: RL (released | freigegeben | validé) printed: 21.11.2018

Signal flow plan

Position control loop

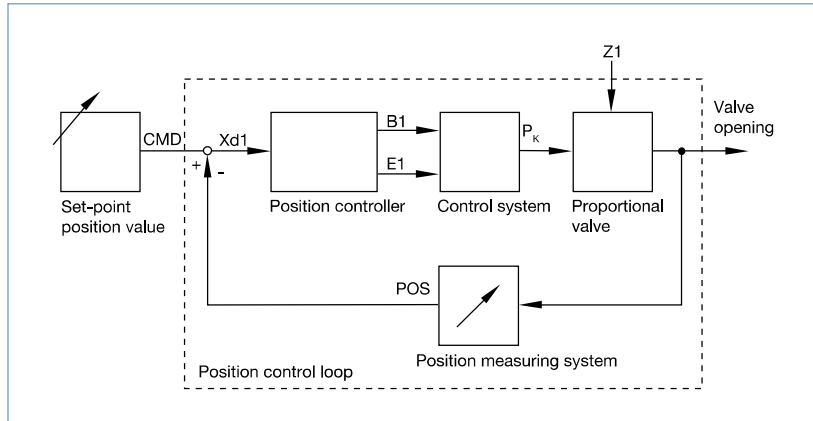

Additional software options of the SideControl positioner Type 8792 (extract)

- Automatic start of the control system
- Automatic or manual characteristics curves selection
- Setting of the seal and the maximum stroke threshold respectively
- Parameterisation of the positioner
- Limitation of the stroke range
- Limitation of the manipulating speed
- Setting of the moving direction
- Configuration of the binary input
- Signal range splitting on several controllers
- Configuration of analogue or 2 binary outputs
- Signal fault detection
- Safety position
- Code protection
- Contrast inversion of the display
- Parametrisable diagnostic functions* / Binary output (option)
 - Operating-hours counter
 - Path accumulator
 - Position monitoring
 - Graphical display of the dwell time density and movement range
 - Monitoring of the mechanical end positions in the armature

*You will find more diagnostic functions with a detailed description in the operating manual for Type 8792/93

Schematic diagram of SideControl, Type 8792

Without Fieldbus interface

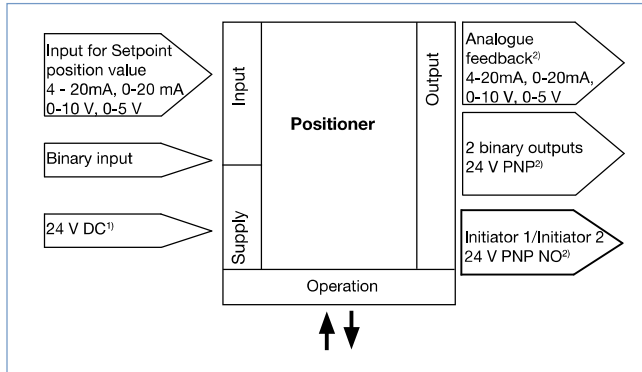

With PROFIBUS DP, DeviceNet, EtherNet/IP, PROFINET, Modbus TCP and büS - Bürkert System Bus

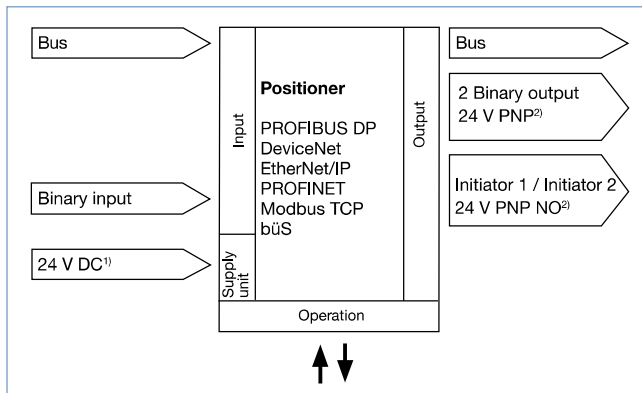

¹ The operating voltage is supplied with a 3-wire unit independent from the setpoint signal

² Alternative options

Dimensions [mm]

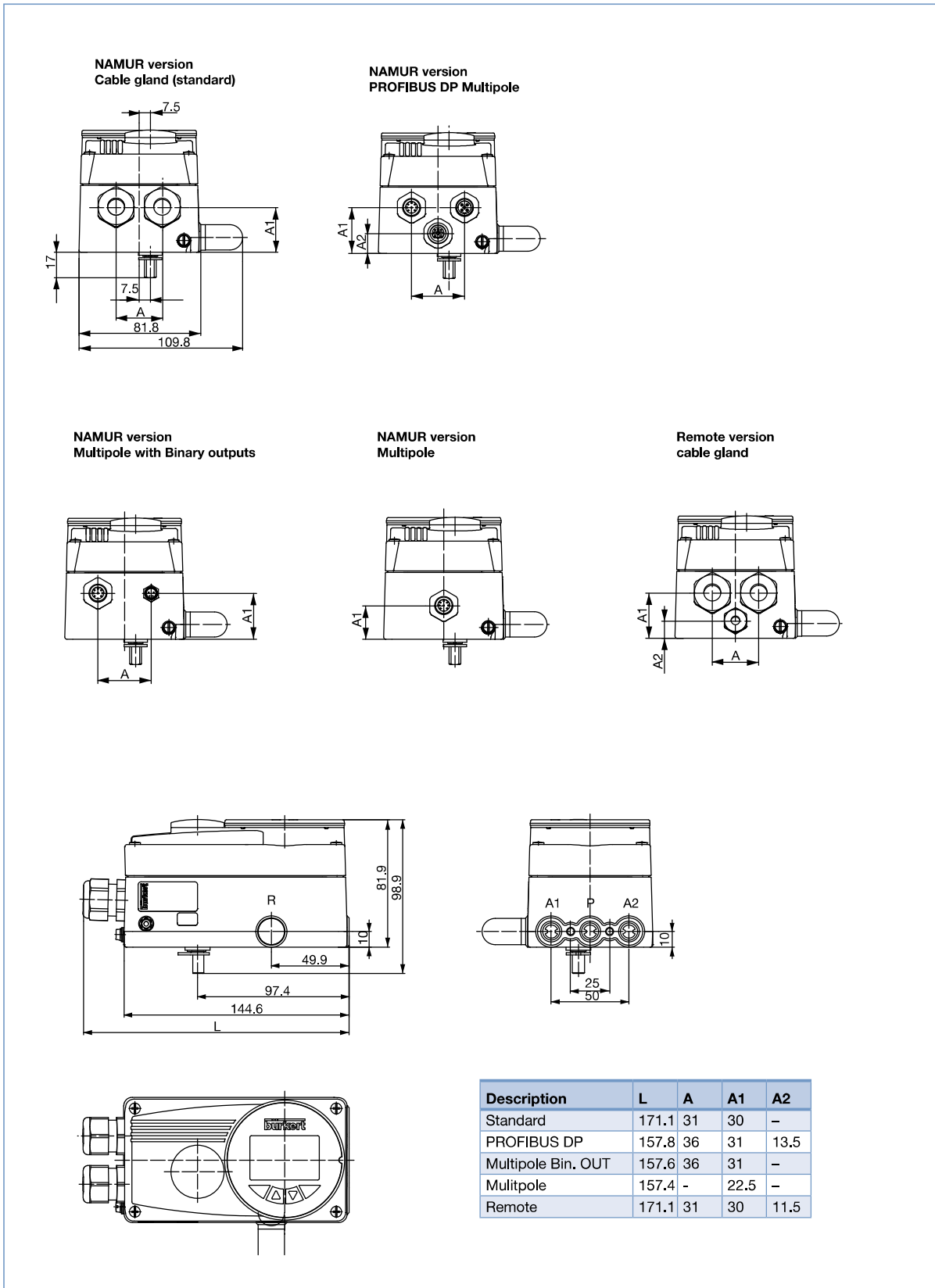

Description	L	A	A1	A2
Standard	171.1	31	30	-
PROFIBUS DP	157.8	36	31	13.5
Multipole Bin. OUT	157.6	36	31	-
Multipole	157.4	-	22.5	-
Remote	171.1	31	30	11.5

DTS 1000121137 EN Version: T Status: RL (released | freigegeben | validé) printed: 21.11.2018

Dimensions [mm], continued

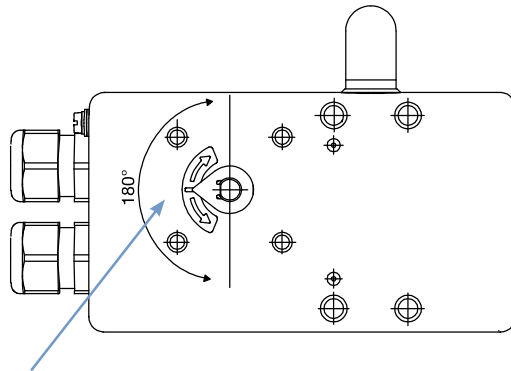

The rotation angle of the sensor must be within a range of 180°

With the valve open approx. 50 %, the sensor indicator should be in this position.

Standard Version

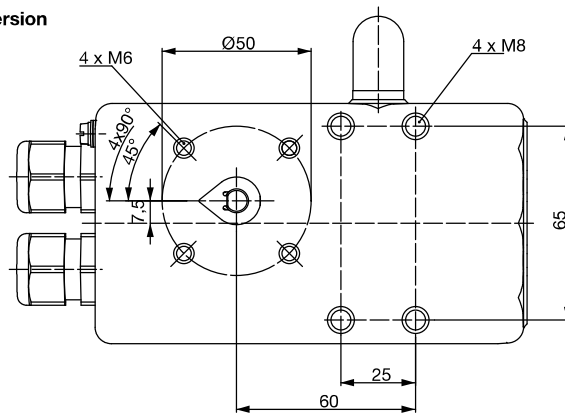

Remote version

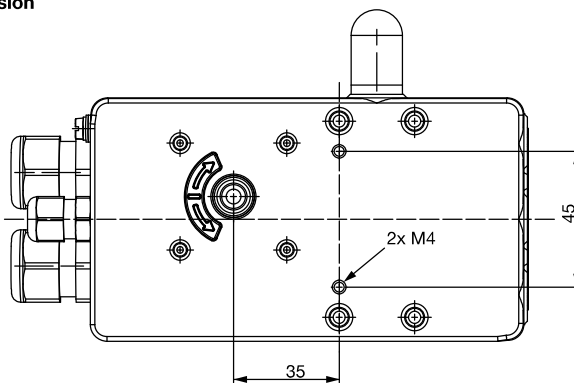

Dimensions [mm], continued

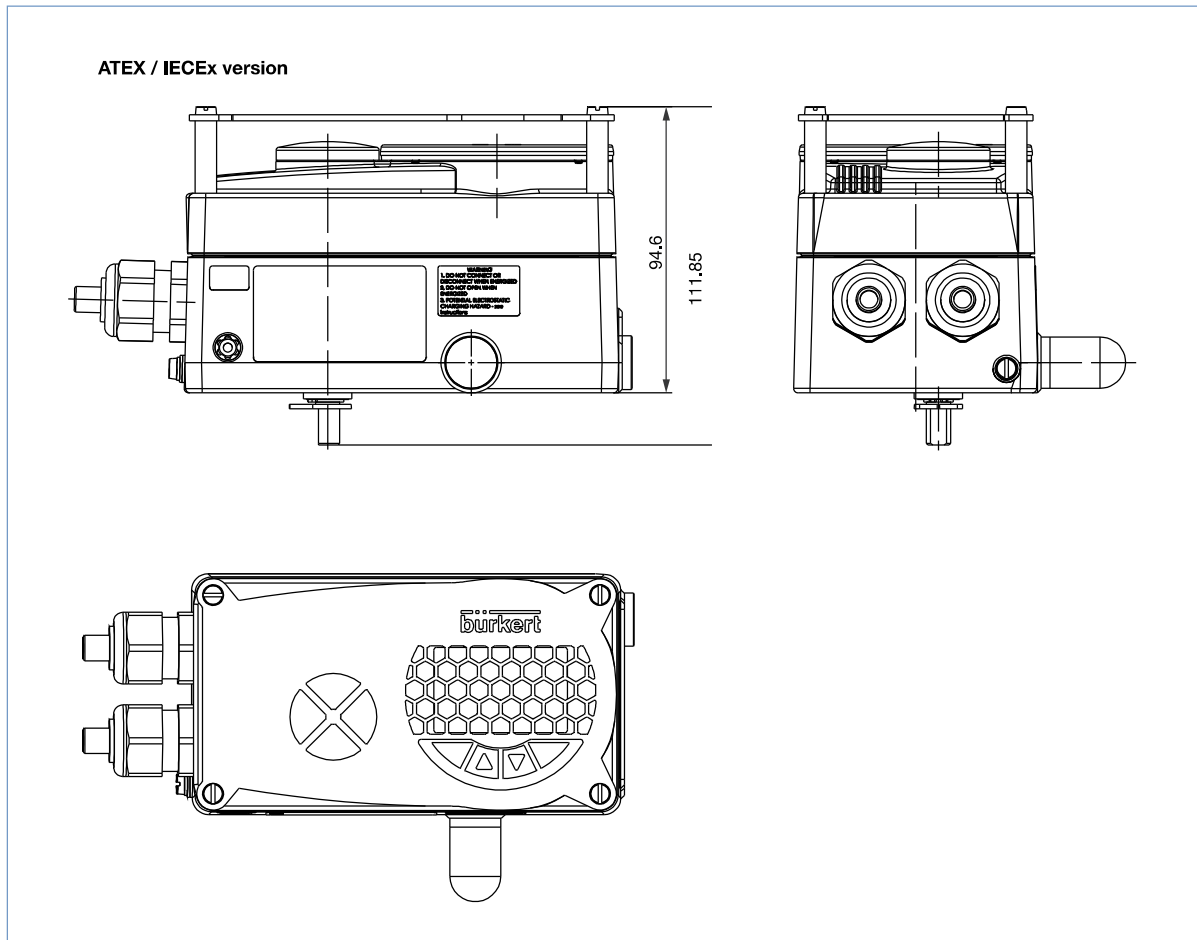

To find your nearest Bürkert facility, click on the orange box → www.burkert.com