

แม่แรงไฮดรอลิก รุ่นยกสูง Multi Stage-Telescopic Jacks

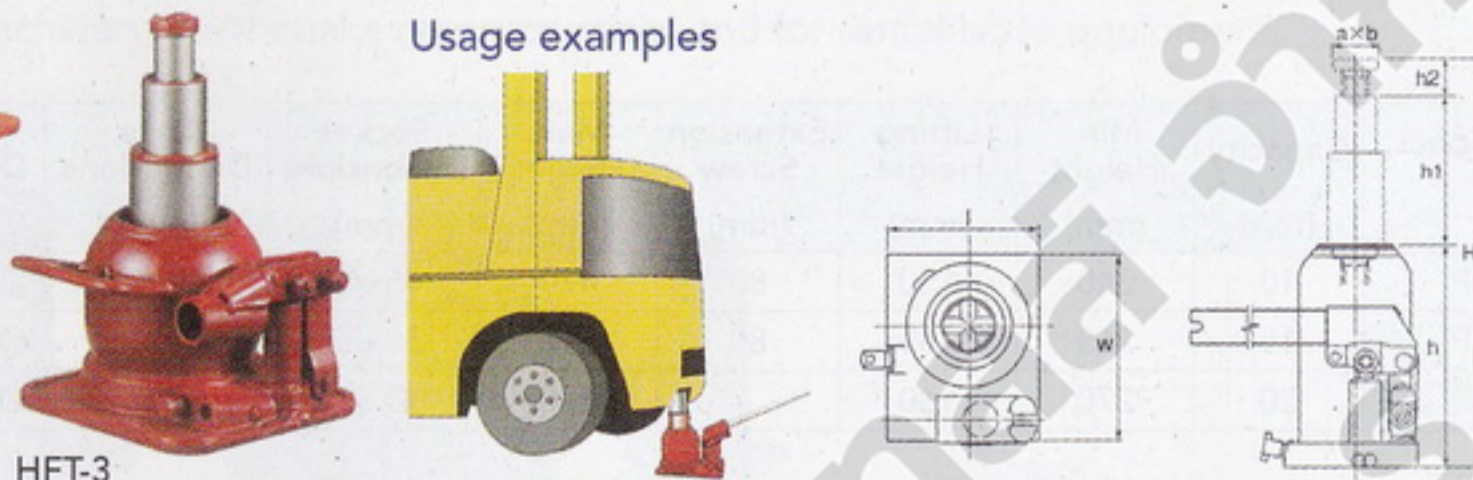

- Used to jack-up low-floor trucks and four-wheel-drive vehicles, etc these jacks can be used with a high stroke from a low position.
- These jacks can be used with a high stroke from a low position.



Specs.	Capacity	Min. Height	Lifting Height	Extension Screw	Max. Height	Socket Dimensions	Base Dimensions	Handle Dimensions	Operating Force	No. of Operations	Adapter	Required Oil	Gross mass
Model	KN (ton)	(mm)	(mm)	(mm)	(mm)	(mm)	(mm)	(mm)	(N)		(cc)	(kg)	
NPD-1.5-5	15 (1.5)	170	205	-	375	Ø 27	90x90	Ø 19.1x380	250	64	-	115	2.7
HPD-4 I	40 (4)	150	160	30	340	31x32	90x110	Ø 21.7x545	200	102	-	189	4.4
HFD-10-2	100 (10)	170	180	70	420	45x47	118x180	Ø 21.7x605	178	279	-	390	8.3
HFD-15	150 (15)	170	180	70	420	45x47	118x180	Ø 21.7x605	178	279	-	505	12

Forklift Use

Specs.	Capacity	Min. Height	Lifting Height	Extension Screw	Max. Height	Socket Dimensions	Base Dimensions	Handle Dimensions	Operating Force	No. of Operations	Required Oil	Gross mass
Model	KN (ton)	(mm)	(mm)	(mm)	(mm)	(mm)	(mm)	(mm)	(N)		(cc)	(kg)
HFD10F-3	100 (10)	120	100	-	220	Ø 38	118x180	Ø 21.7x605	178	93	245	6.8
HFT-3	30 (3)	120	150	-	270	Ø 34	154x167	Ø 21.7x600	274	108	330	8.2

- * Horizontal use is not recommended.
- * The HFT-3 is a three stage-telescopic jack.

แม่แรงไฮดรอลิก รุ่นตัวเล็กพิเศษ Mini Jacks



- These models can operate both vertically and horizontally in extremely tight locations.
- They are the smallest product in the hydraulic jack range. Centering operations and level adjustment can be performed easily.



Horizontal spec. model also available
Usage only possible in the range of 90° in the orientation of the diagram

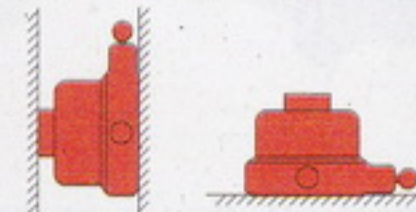

Usage examples

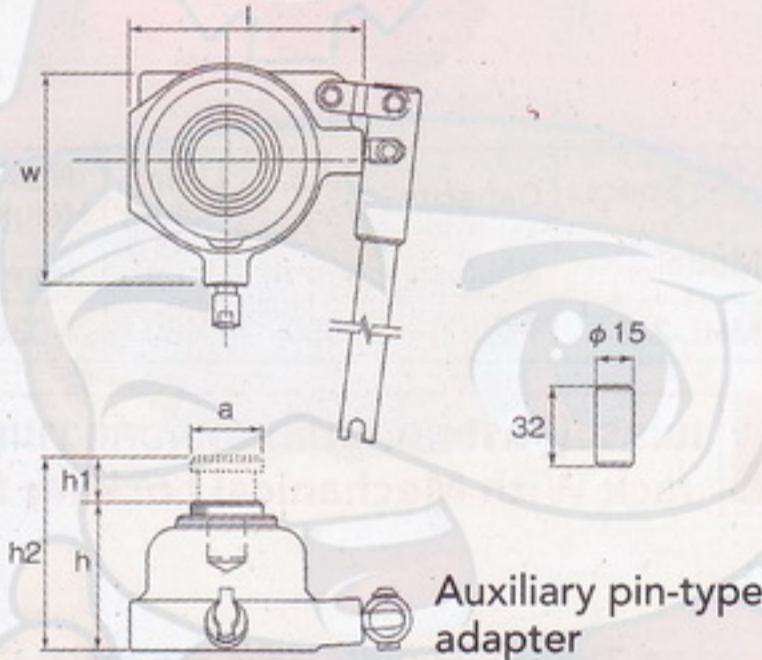
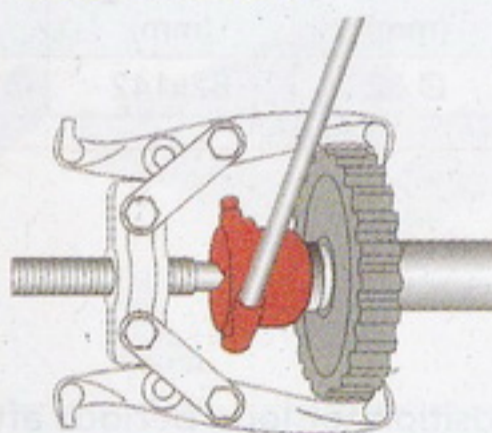

Specs.	Capacity	Min. Height	Lifting Height	Max. Height	Socket Dimensions	Base Dimensions	Handle Dimensions	Operating Force	No. of Operations	Adapter	Required Oil	Gross mass
Model	KN (ton)	(mm)	(mm)	(mm)	(mm)	(mm)	(mm)	(mm)	(N)		(cc)	(kg)
MMJ-5C-2	50 (5)	60	20	80	Ø 28	94x89	Ø 14x240	255	36	thin-type/pin-type	25	1.7
MMJ-5T-2	50 (5)	85	40	125	Ø 28	94x89	Ø 14x240	255	75	thin-type/pin-type	40	2.2
MMJ-10	100 (10)	120	30	150	Ø 42	102x108	Ø 18x440	274	45	thin-type	77	4.9
MMJ-20	200 (20)	130	30	160	Ø 53	112x119	Ø 22x605	343	63	thin-type	110	7.7
MMJ-50Y	500 (50)	140	30	170	Ø 80	174x178	Ø 22x680	382	97	thin-type	370	19.0

