



Perfecting the Air

# INVERTER AIR COOLED PACKAGED AIR CONDITIONERS

FLOOR STANDING TYPE

DUCT TYPE



**R-410A**

COOLING ONLY 50Hz



DIRECT AIR BLOW    DUCT CONNECTION

**FLOOR STANDING TYPE**

**DUCT TYPE**

**OUTDOOR UNIT**

# Inverter Packaged Air Conditioner Line Up for Factories and Offices

## Product Line Up **R-410A**

### RZUR-Q Series

Cooling only

50Hz

Capacity	kW Btu/h	23.2 79,000	28.9 99,000	
<b>FLOOR STANDING TYPE (DIRECT AIR BLOW)</b> <small>Specifications Page 7</small>		 FVGR08QV2S	 FVGR10QV2S	
	<b>OUTDOOR UNIT</b>	 RZUR08QY2S	 RZUR10QY2S	











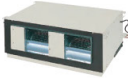
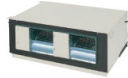
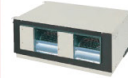
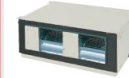
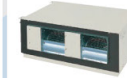

### RZUR-Q Series

Cooling only

#### Enhanced lineup

Wider capacity range with 2 new lineups of 12 and 20 HP

50Hz

Capacity	kW Btu/h	23.2 79,000	28.9 99,000	34.7 118,000	46.3 158,000	52.0 177,000	57.7 197,000
<b>FLOOR STANDING TYPE (DUCT CONNECTION)</b> <small>Specifications Page 7</small>			 FVPR10QY2S	 FVPR12QY2S	 FVPR16QY2S	 FVPR18QY2S	 FVPR20QY2S
	<b>DUCT TYPE</b> <small>Specifications Page 8</small>	 FDR08QY2S	 FDR10QY2S	 FDR12QY2S	 FDR16QY2S	 FDR18QY2S	 FDR20QY2S
<b>OUTDOOR UNIT</b>	 RZUR08QY2S	 RZUR10QY2S	 RZUR12QY2S	 RZUR16QY2S	 RZUR18QY2S	 RZUR20QY2S	

#### DIRECT AIR BLOW

Direct air blow from indoor unit with plenum

- Comfortable factory air conditioning using multiple indoor units installed in accordance with the space.
- Installation is next to walls, so units will not affect the factory layout even if the changes are made.

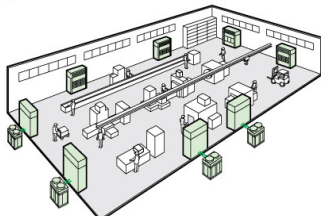

#### DUCT CONNECTION / DUCT TYPE

Air blow via connected ducts

- Comfortable air conditioning of the entire factory by connecting a blow duct at the top of the indoor unit.

Note: Ducts to be procured locally.

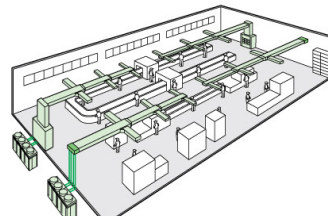

## Cooling Capacity improvement

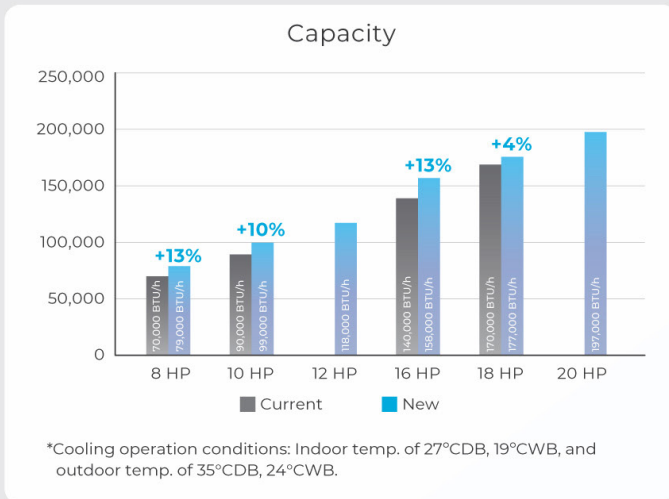

RZUR-Q series increase Cooling Capacity to full BTU/h to maximize product potential.



## SEER Improvement

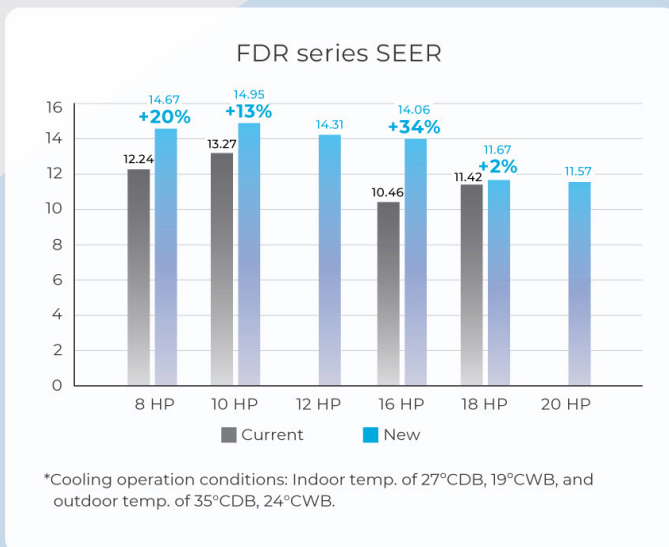

FDR-Q series provides greater energy saving due to higher SEER\* as compared to FDR-P series.

\*SEER: Seasonal Energy Efficiency Ratio



## Design flexibility

### Compact & lightweight design

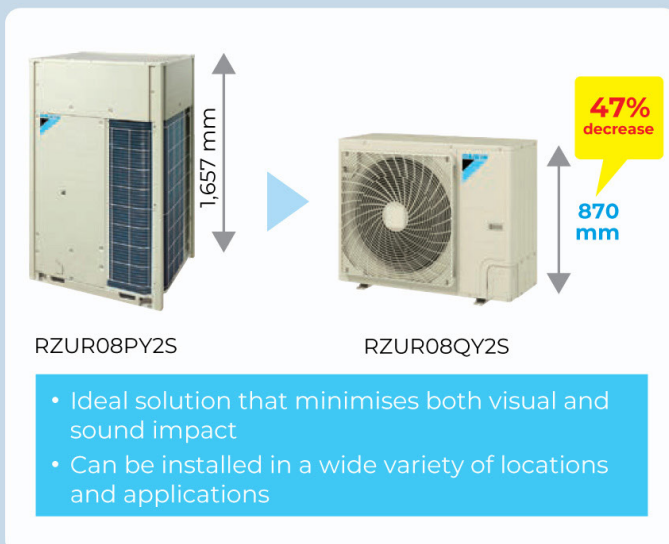

The new design has been optimised for the RZUR08QY2S with the height reduced to only 870 mm.

This low height casing design provides occupants with a clear, unobstructed view of the scenery.

## Automatic adjustment of external static pressure New

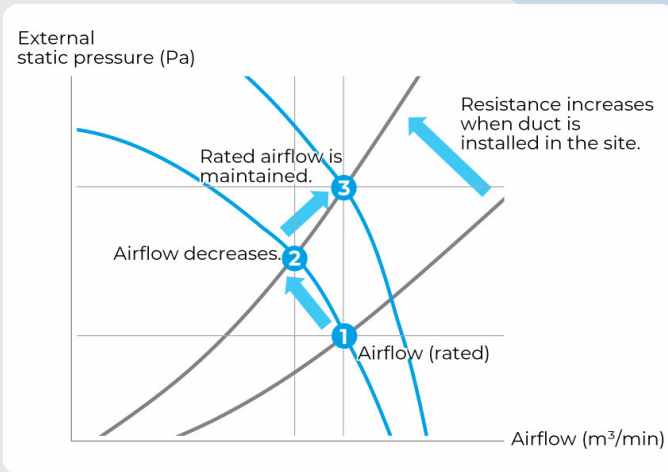

The RZUR08QY2S model has the external static pressure automatic adjustment function for maintaining the rated airflow and capacity by automatically adjusting the external static pressure during the test operation to suit the resistance of the installation site.

\* For RZUR08QY2S Maximum Automatic Adjustment External Static Pressure is 40Pa. This function is set as default no field setting required.  
 \*\* For Other models except RZUR08QY2S; High External Static Pressure Mode is up to 78.4Pa can be achieved via field setting.

## Comfort

### Long Air Throw 23 m.

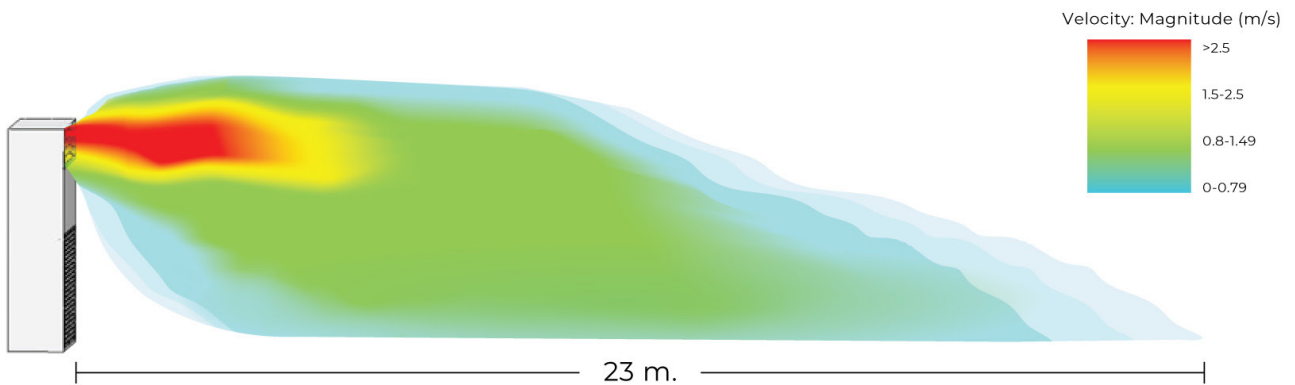

\*For FVGR08/10QV2S Test result from Daikin Airconditioning (Thailand) Ltd in May 2023 Test condition: Dry Bulb temperature 35 °C Wet Bulb temperature 26°C, Fan speed Setting: High, Operation mode: Fan(Fan only operation)

### Nighttime quiet operation function

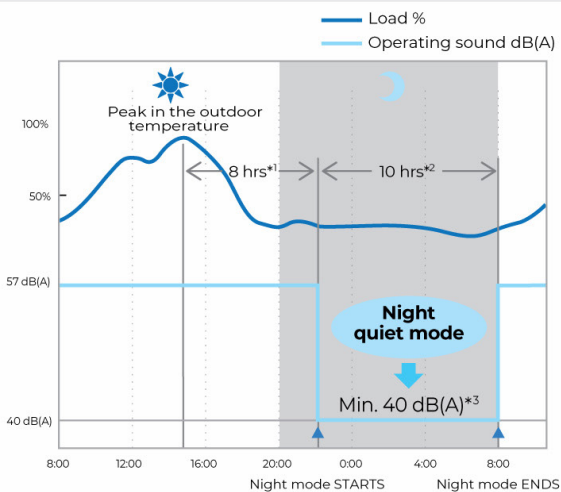

The nighttime quiet operation function automatically suppresses the nighttime operating sound by reducing operation capacity to maintain the quiet environment of the neighborhood. Three selectable modes are available depending on the required level.

- \*1. Initial setting is 8 hours. Can be selected from 6, 8 and 10 hours.
- \*2. Initial setting is 9 hours. Can be selected from 8, 9 and 10 hours.
- \*3. In case of RZUR10QY2S.

Notes: · This function is available in setting at site.

- The operating sound in quiet operation mode is the actual value measured by our company.
- The relationship of outdoor temperature (load) and time shown above is just an example.

# Reliability

## Backup operation function

### Compressor backup operation function

Emergency operation



Malfunction

\* For RZUR12-20QY2S models. On-site settings are required using the PCB of the outdoor unit.

## Centralized management system extension

High efficiency integrated control

### Intelligent Touch Manager

Lighting and ventilation control, energy use can be monitored and managed by one controller.

Intelligent Touch Manager

10.4 inch width touch screen



Centralized management can integrate with D-BACS system with high speed data transfer.

Centralized control is now available when using with Inverter packaged air conditioners.

Display of air filter cleaning times and self-inspection function for simple maintenance.

## Auto restart

Automatically turn on the operation unit after facing unexpected shut down.

\* Auto restart function can be turned ON/OFF by field setting

# Automatic refrigerant charge function

Contribute to optimised operation efficiency, higher quality and easier installation.

## Optimised operation efficiency New

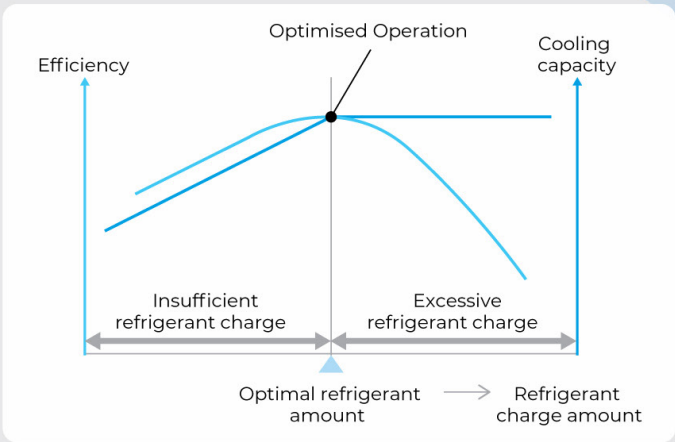

This function prevents a capacity shortage or energy loss due to excessive or insufficient refrigerant.

## Higher quality and easier installation New

**1** Calculation of necessary refrigerant amount from design drawing

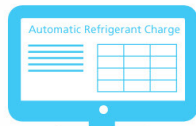

**2** Start of automatic refrigerant charge operation

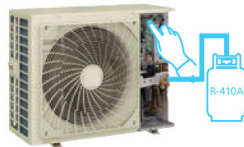

- Automatic completion by proper refrigerant amount
- Monitoring refrigerant charging is unnecessary
- No recalculation of charge amounts due to minor design changes locally

The automatic refrigerant charge function automates the charging of the proper refrigerant amount and easy start by pressing one button.

\* There are conditions in the range of ambient temperature in which the automatic refrigerant charge can be used. Refer to the installation manual for details.

\* The refrigerant amount that can be automatically charged may differ from the additional refrigerant amount that is provided from calculations, but there are no problems in performance and quality.

# Enhanced varieties of factory modification

○ Standard model  
  New functions   Factory modification

Factory Modification	Floor Standing Type		Duct Type
	Direct Air Blow	Duct Connection	
Auto restart	○	○	○
Change fan motor and pulley	-	□	□
Discharge grill plenum chamber	○	□	□
Side discharge grill on discharge plenum chamber	□	□	-
Front suction high efficiency filter chamber	-	□	-
Front suction base flange for front suction high efficiency filter chamber	-	□	-
Suction grill for front suction high efficiency filter chamber	-	□	-
Rear suction	-	□	-
Drain pump	□	□	-

# Electricity Cost compare with Non-Inverter model

Electricity cost/year reduce **35%** averagely

SBU	Non-inverter		Inverter		Diff Electric cost/year	% Reduce
	Model	Electric cost / Year	Model	Electric cost / Year		
Duct	AFDR08NY1	129,518 THB	FDR08QY2S	78,623 THB	<b>50,895 THB</b>	<b>39%</b>
	AFDR10NY1	164,834 THB	FDR10QY2S	96,682 THB	<b>68,151 THB</b>	<b>41%</b>
	AFDR13NY1	214,861 THB	FDR12QY2S	121,925 THB	<b>92,936 THB</b>	<b>43%</b>
	AFDR15NY1	258,047 THB	FDR16QY2S	164,068 THB	<b>93,979 THB</b>	<b>36%</b>
	AFDR18NY1	307,880 THB	FDR18QY2S	221,440 THB	<b>86,441 THB</b>	<b>28%</b>
	AFDR20NY1	361,788 THB	FDR20QY2S	248,591 THB	<b>113,197 THB</b>	<b>31%</b>
Floor Direct blow	AFVR08NV1	123,825 THB	FVGR08QV2S	82,034 THB	<b>41,791 THB</b>	<b>34%</b>
	AFVR10NV1	161,688 THB	FVGR10QV2S	106,987 THB	<b>54,701 THB</b>	<b>34%</b>
Floor Duct Connection	AFPR10NY1	164,834 THB	FVPR10QY2S	103,836 THB	<b>60,997 THB</b>	<b>37%</b>
	AFPR13NY1	213,952 THB	FVPR12QY2S	151,739 THB	<b>62,162 THB</b>	<b>29%</b>
	AFPR15NY1	257,066 THB	FVPR16QY2S	77,038 THB	<b>80,029 THB</b>	<b>31%</b>
	AFPR18NY1	304,171 THB	FVPR18QY2S	204,123 THB	<b>100,048 THB</b>	<b>33%</b>
	AFPR20NY1	357,189 THB	FVPR20QY2S	226,651 THB	<b>130,538 THB</b>	<b>37%</b>

\*Electric cost refer calculation method from ISO16358-1:2013 same method as EGAT Air Conditioning No 5 Label (Operating 8hr/day, Electric cost 5.00Baht/unit), Calculation base on same capacity(BTU/h)



# Specifications

## FLOOR STANDING TYPE

### DIRECT AIR BLOW

Model Name	Indoor unit		FVGR08QV2S		FVGR10QV2S	
	Outdoor unit		RZUR08QY2S		RZUR10QY2S	
Rated cooling capacity*1 (Min-Max.)	Btu/h		79,000 (11,000-80,000)		99,000 (21,000-100,000)	
	kW		23.2 (3.10-23.50)		28.9 (6.10-29.30)	
Power consumption <sup>1</sup>	kW		8.89		11.33	
SEER			14.06		13.51	
COP			2.61		2.55	
Indoor unit	Power supply		1 Phase, 220 V, 50 Hz			
	Colour		Ivory White			
	Air flow rate (H/L)		m <sup>3</sup> /min		75 / 66 / 52	
			cfm		2,650 / 2,330 / 1,840	
	Fan	Motor output	kW		0.245×2	
			Drive		Direct Drive	
	Dimensions (H×W×D)		mm		1,870×1,170×510	
	Machine weight		kg		155	
Sound level		dB(A)		60.5 / 57.5 / 53.0		
Drain		mm		PS 1B Internal thread		
Outdoor unit	Power supply		3 Phase, 380 V, 50 Hz			
	Colour		Ivory white			
	Compressor	Type	Hermetically sealed swing type		Hermetically sealed scroll type	
		Motor output	kW		kW	
	Coil type		Micro Channel		Cross Fin Coil	
	Air flow rate (H)		m <sup>3</sup> /min		m <sup>3</sup> /min	
			cfm		cfm	
	Dimensions (H×W×D)		mm		mm	
	Machine weight		kg		kg	
	Sound level <sup>2</sup>		dB(A)		dB(A)	
	Operation range		°CDB		°CDB	
Refrigerant charge		kg		kg		
Refrigerant Piping	Liquid	mm		mm		
	Gas	mm		mm		
Max. piping length	m		70 (equivalent length 90 m)			
Max. level difference	m		50*		50	
Safety Device	High Pressure Switch, Fan Driver Overload Protector, Inverter Overload Protector, Fuse, Bimetal Thermostat(Overload relay)					

\* 40M if the outdoor unit is lower than the indoor unit

\*\* SEER refer calculation method from JIS C 9612

### DUCT CONNECTION

Model Name	Indoor unit		FVPR10QY2S	FVPR12QY2S	FVPR16QY2S	FVPR18QY2S	FVPR20QY2S	
	Outdoor unit		RZUR10QY2S	RZUR12QY2S	RZUR16QY2S	RZUR18QY2S	RZUR20QY2S	
Rated cooling capacity*1,4 (Min-Max.)	Btu/h		99,000 (21,000-100,000)	118,000 (45,000-120,000)	158,000 (44,000-160,000)	177,000 (47,000-180,000)	197,000 (47,000-200,000)	
	kW		28.90 (6.1-29.30)	34.70 (13.3-35.20)	46.30 (12.9-46.90)	52.00 (13.7-52.80)	57.70 (13.7-58.60)	
Power consumption <sup>1,4</sup>	kW		10.90	12.39	15.70	20.00	25.42	
SEER			13.92	11.35	13.03	12.66	12.69	
COP			2.65	2.80	2.95	2.60	2.27	
Indoor unit	Power supply		3 Phase, 380 V, 50 Hz					
	Colour		Ivory White					
	Air flow rate (H)		m <sup>3</sup> /min		m <sup>3</sup> /min		m <sup>3</sup> /min	
			cfm		cfm		cfm	
	External static pressure <sup>3</sup>		Pa		Pa		Pa	
	Fan	Motor output	kW		kW		kW	
			Drive		Drive		Drive	
	Dimensions (H×W×D)		mm		mm		mm	
Machine weight		kg		kg		kg		
Sound level		dB(A)		dB(A)		dB(A)		
Drain		mm		mm		mm		
Outdoor unit	Power supply		3 Phase, 380 V, 50 Hz					
	Colour		Ivory white					
	Compressor	Type	Hermetically sealed scroll type					
		Motor output	kW		kW		kW	
	Coil type		Cross Fin Coil					
	Air flow rate (H)		m <sup>3</sup> /min		m <sup>3</sup> /min		m <sup>3</sup> /min	
			cfm		cfm		cfm	
	Dimensions (H×W×D)		mm		mm		mm	
	Machine weight		kg		kg		kg	
	Sound level <sup>2</sup>		dB(A)		dB(A)		dB(A)	
	Operation range		°CDB		°CDB		°CDB	
Refrigerant charge		kg		kg		kg		
Refrigerant Piping	Liquid	mm		mm		mm		
	Gas	mm		mm		mm		
Max. piping length	m		70 (equivalent length 90 m)					
Max. level difference	m		50		50			
Safety Device	High Pressure Switch, Fan Driver Overload Protector, Overcurrent Relay, Inverter Overload Protector							

Note: \*1. Indoor temp.: 27°CDB, 19°CWB / outdoor temp.: 35°CDB, 24°CWB / Equivalent piping length: 7.5 m, level difference: 0 m.

\*2. Anechoic chamber conversion value, measured at a point 1 m in front of the unit at a height of 1.5 m. During actual operation, these values are normally somewhat higher as a result of ambient conditions and oil recovery mode. When there is concern for noise in the surrounding area such as residences, we recommend investigating the installation location and taking soundproofing measures.

\*3. The value is the external static pressure with standard pulley.

\*4. Capacity are net, including a deduction for cooling for indoor fan motor heat

\*\* SEER refer calculation method from JIS C 9612

## DUCT TYPE

Model Name	Indoor unit		FDR08QY2S	FDR10QY2S	FDR12QY2S	FDR16QY2S	FDR18QY2S	FDR20QY2S
	Outdoor unit		RZUR08QY2S	RZUR10QY2S	RZUR12QY2S	RZUR16QY2S	RZUR18QY2S	RZUR20QY2S
Rated cooling capacity*1,5 (Min-Max.)	Btu/h		79,000 (11,000-80,000)	99,000 (21,000-100,000)	118,000 (45,000-120,000)	158,000 (44,000-160,000)	177,000 (47,000-180,000)	197,000 (47,000-200,000)
	kW		23.20 (3.1-23.50)	28.90 (6.1-29.30)	34.70 (13.3-35.20)	46.30 (12.9-46.90)	52.00 (13.7-52.80)	57.70 (13.7-58.60)
Power consumption*1,5	kW		8.92	10.70	11.19	15.69	21.22	26.39
SEER			14.67	14.95	14.13	14.06	11.67	11.57
COP			2.60	2.70	3.10	2.95	2.45	2.19
Indoor unit	Power supply		3 Phase, 380 V, 50 Hz					
	Colour		Ivory White					
	Air flow rate (H)	m <sup>3</sup> /min	78		120		166	
		cfm	2,750		4,240		5,860	
	External static pressure <sup>3</sup>		98		150			
	Fan	Motor output	1.5			2.2		
		Drive	Belt Drive					
	Dimensions (H×W×D)		500×1,330×850		625×1,980×850		760×2,195×870	
	Machine weight		106		187		216	
	Sound level		57		59		60	
Drain		PS 3/4B Internal thread		PS 1B Internal thread				
Outdoor unit	Power supply		3 Phase, 380 V, 50 Hz					
	Colour		Ivory white					
	Compressor	Type	Hermetically sealed swing type		Hermetically sealed scroll type			
		Motor output	3.2×1	4.5×1	(3.5×1)+(3.5×1)	(4.9×1)+(4.2×1)		
			Micro Channel		Cross fin coil			
	Air flow rate (H)		126	178	257	297		
	Dimensions (H×W×D)		870×1,100×460		1,657×930×765		1,657×1,240×765	
	Machine weight		113	185	260	291		
	Sound level*2		61	57	60	65		
	Operation range		10 to 49					
Refrigerant charge		3.8	6.7	8.2	11.7			
Refrigerant Piping	Liquid	Ø 9.5 (Brazing)		Ø 12.7 (Brazing)		Ø 15.9 (Brazing)		
	Gas	Ø 19.1 (Brazing)	Ø 22.2 (Brazing)	Ø 28.6 (Brazing)				
Max. piping length		70 (equivalent length 90 m)						
Max. level difference		50 <sup>4</sup>	50					
Safety Device		High Pressure Switch, Fan Driver Overload Protector, Inverter Overload Protector, Fuse, Bimetal thermostat (Overload Relay)						

Note: \*1. Indoor temp.: 27°CDB, 19°CWB / outdoor temp.: 35°CDB, 24°CWB / Equivalent piping length: 7.5 m, level difference: 0 m.

\*2. Anechoic chamber conversion value, measured at a point 1 m in front of the unit at a height of 1.5 m.

During actual operation, these values are normally somewhat higher as a result of ambient conditions and oil recovery mode.

When there is concern for noise the surrounding area such as residences, we recommend investigating the installation location and taking soundproofing measures.

\*3. The value is the external static pressure with standard pulley.

\*4. Max. 40 m if the outdoor unit is lower than the indoor unit.

\*5. Capacity are net, including a deduction for cooling for indoor fan motor heat

\*\* SEER refer calculation method from JIS C 9612

## Option

### FLOOR STANDING TYPE

Option	Direct Air Blow		Duct Connection	
	FVGR08/10QV2S	FVPR10QY2S	FVPR12/16QY2S	FVPR18/20QY2S
Discharge grill plenum chamber (Including pulley and belt)	—	BPCV10Q	BPCV16Q	BPCV20Q
Filter chamber	—	BFU1B250	BFU1B400	BFU1B500

### DUCT TYPE

Option	FDR08QY2S	FDR10QY2S	FDR12QY2S	FDR16QY2S	FDR18QY2S	FDR20QY2S
Discharge grill plenum chamber (Including pulley and belt)	BPCD10Q		BPCD16Q		BPCD20Q	

### CONTROL SYSTEM

Option	FVGR-QY2S	FVPR-QY2S	FDR-QY2S
Simplified remote controller	BRC2E61 (Built-in)	BRC2E61 (Built-in)	BRC2E61
Navigator remote controller	—	BRC1E63	
Intelligent touch controller	DCS601C51		
Central remote controller	DCS302CA61		
Unified ON/OFF controller	DCS301B61		
Schedule timer	DST301BA61		
Wiring adaptor for electrical appendices (Group control adaptor) ★	KRP4AA51		
Wiring adaptor for electrical appendices ★	—	KRP2A61	
Adaptor for wiring ★	—		
Adaptor for wiring (operation status output) ★	—		
Remote sensor (for indoor temperature)	BRCS01A-6		
Mounting plate for adaptor PCB ☆	BRP20A-3		BRP20A-2

Note: Mounting plate ☆ is necessary for each adaptor marked ★.

# Fan Performance

FLOOR STANDING TYPE

## DUCT CONNECTION

FVPR10QY2S

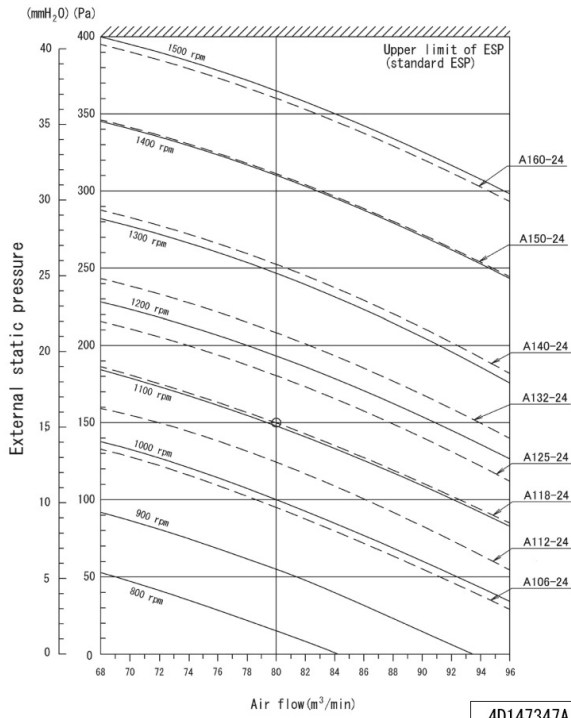

FVPR12QY2S  
FVPR16QY2S

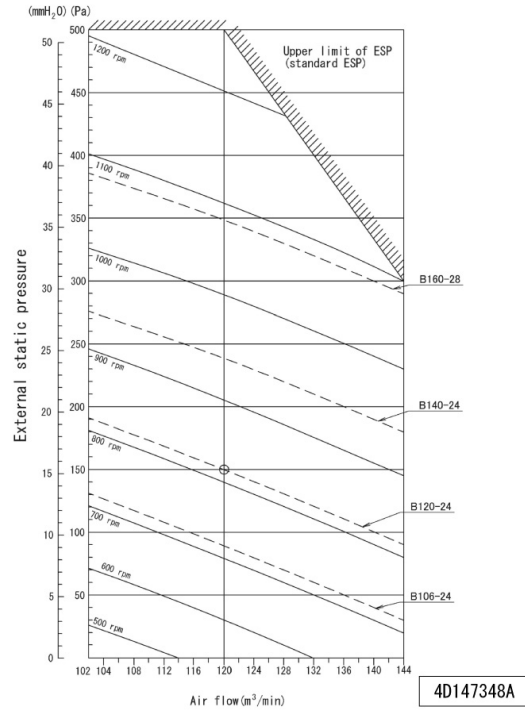

FVPR18QY2S  
FVPR20QY2S

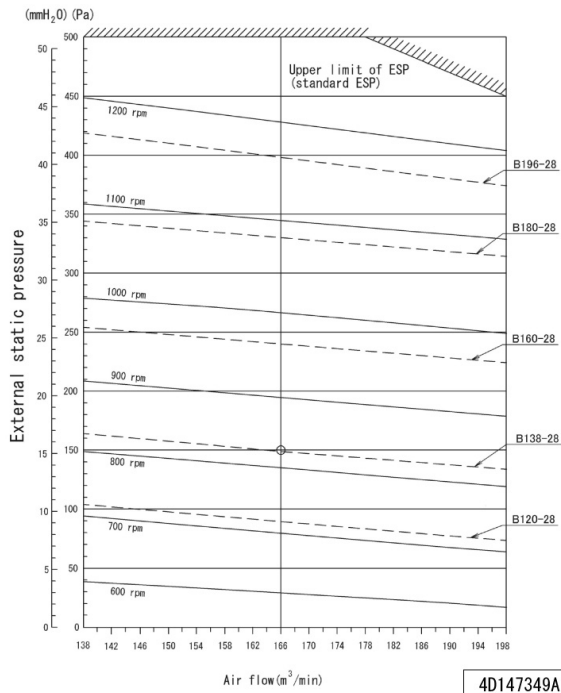

## DUCT TYPE

**FDR08QY2S  
FDR10QY2S**

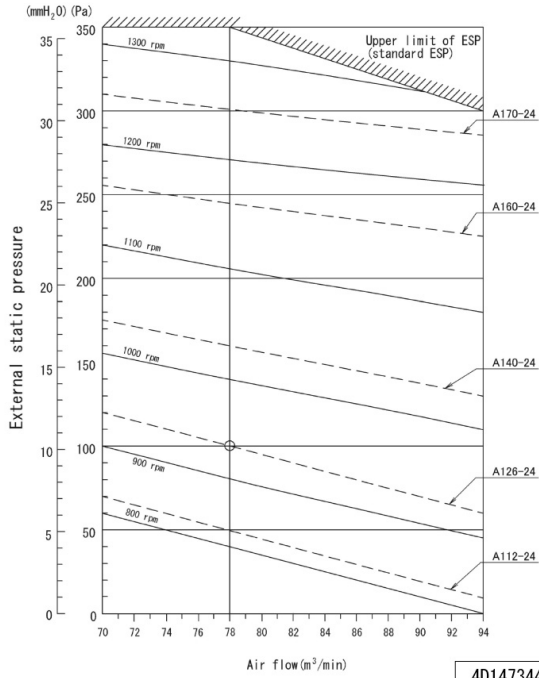

4D147344A

**FDR12QY2S  
FDR16QY2S**

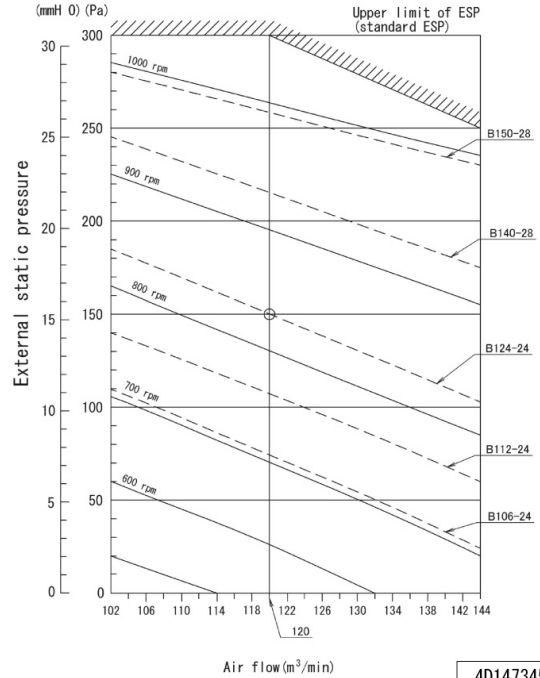

4D147345A

**FDR18QY2S  
FDR20QY2S**

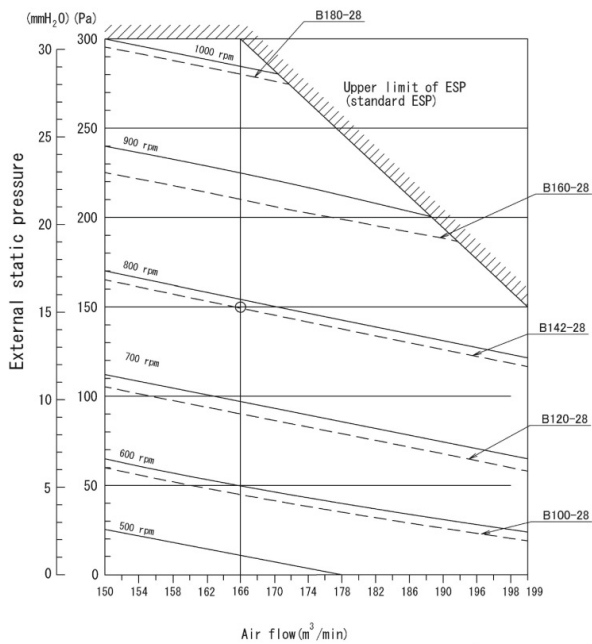

4D147346A



# RZUR10QY2S

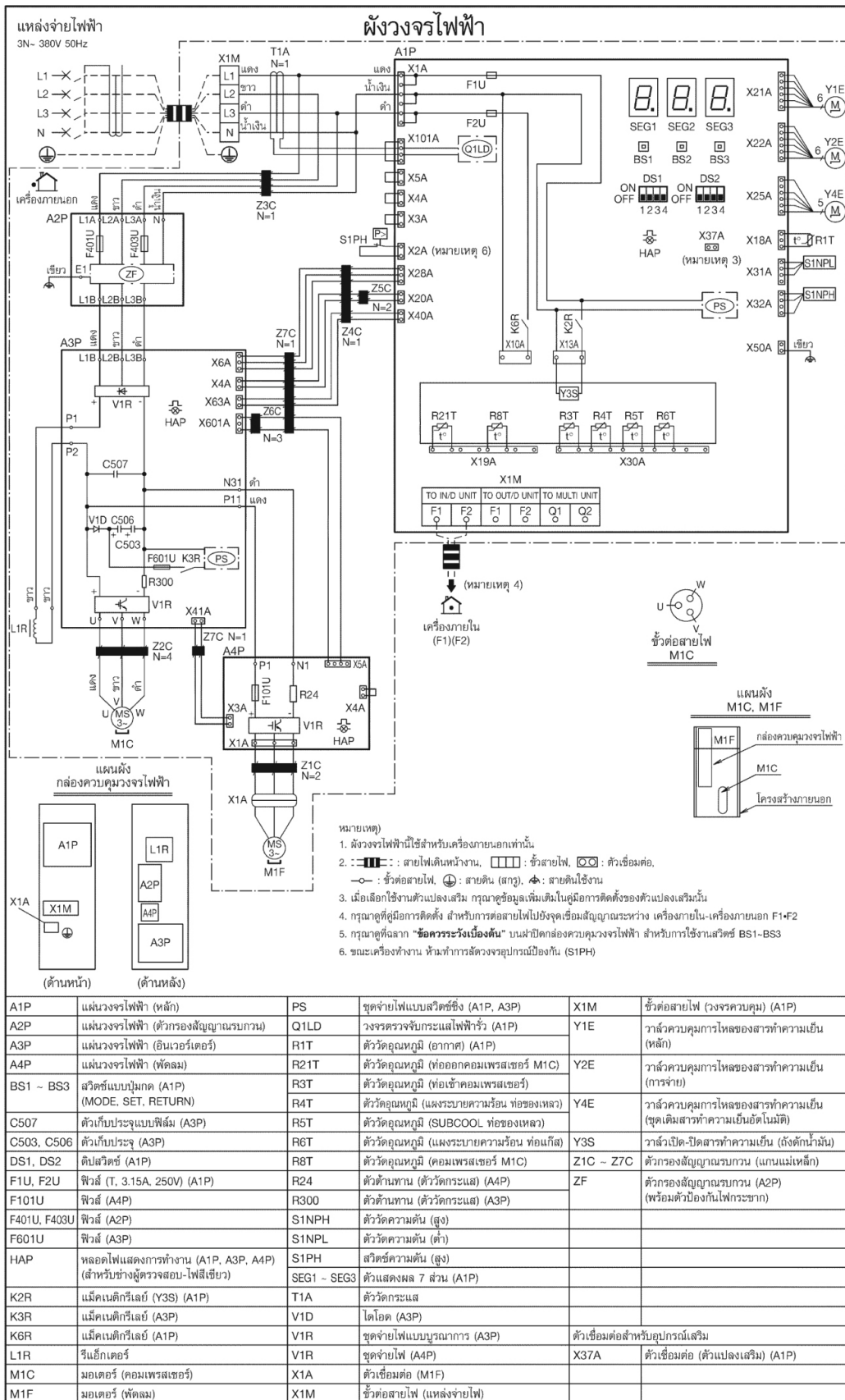

3D144823A



# MEMO

A large, empty white rectangular area intended for writing a memo. The area is completely blank, with no text or markings inside. It is surrounded by a light blue border at the top and sides, and a light grey border at the bottom.

# Piping Diagrams

## RZUR08QY2S

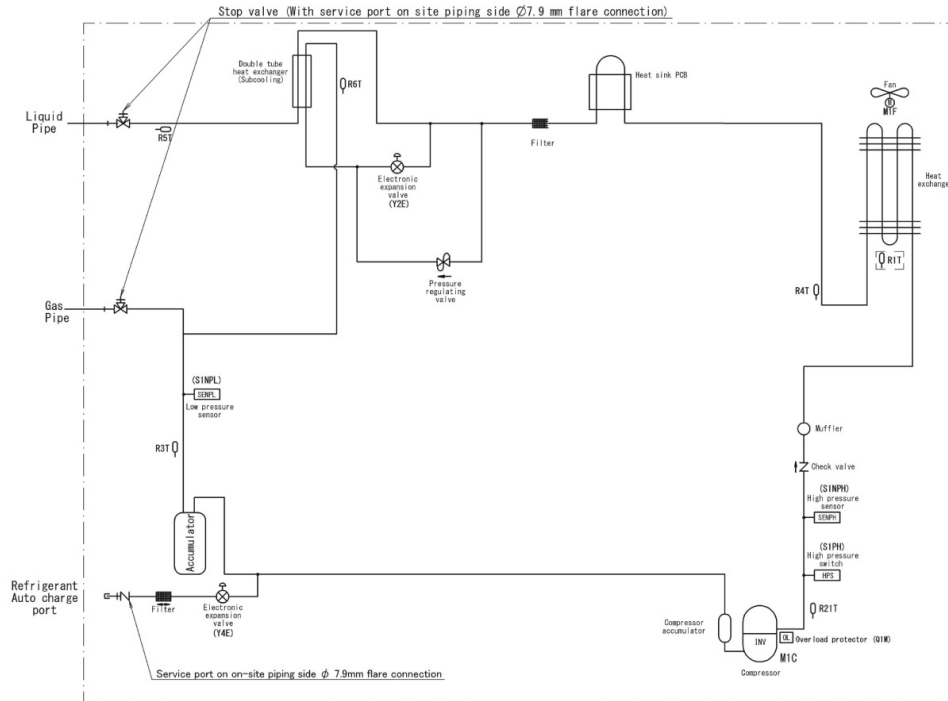

3D129633

## RZUR10QY2S

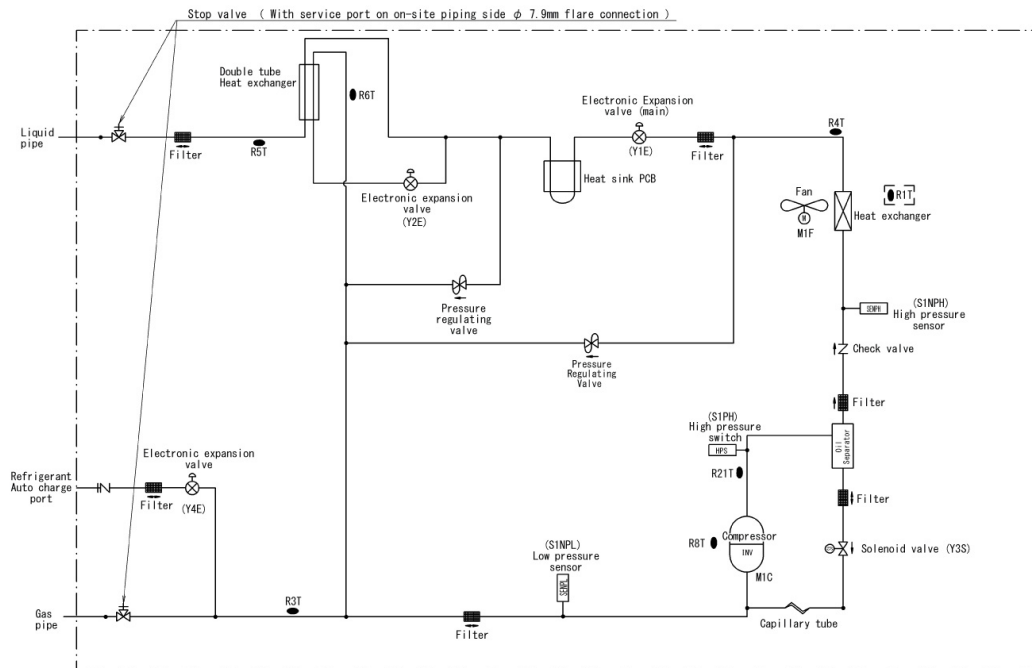

3D147181

# RZUR12/16/18/20QY2S

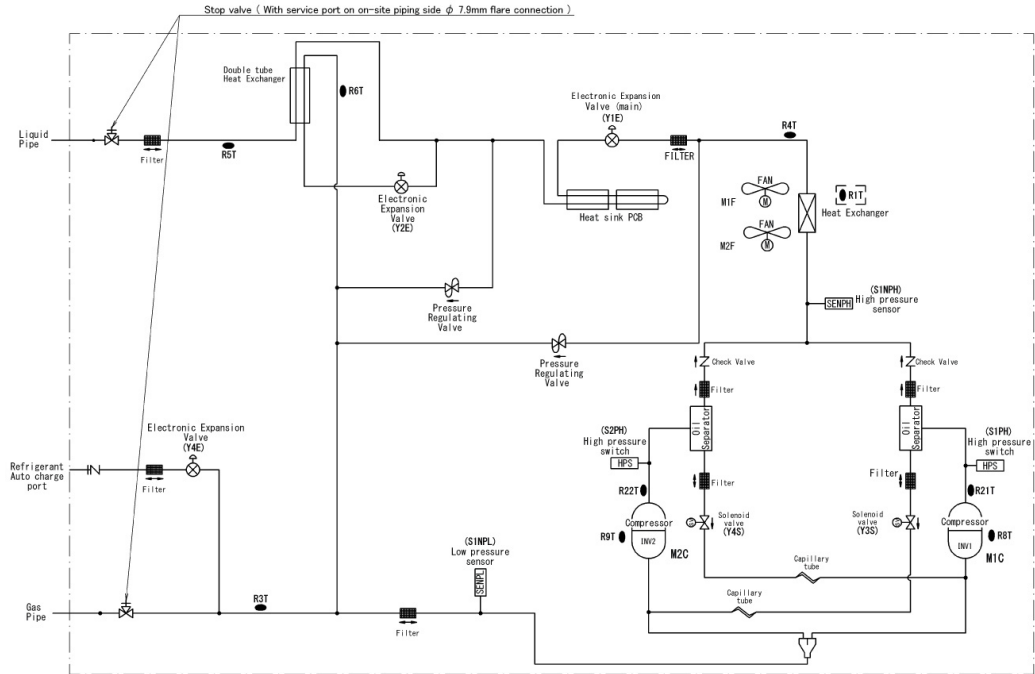

3D147180

# Dimensions (Unit:mm)

## FLOOR STANDING TYPE

### DIRECT AIR BLOW

FVGR08QV2S  
FVGR10QV2S

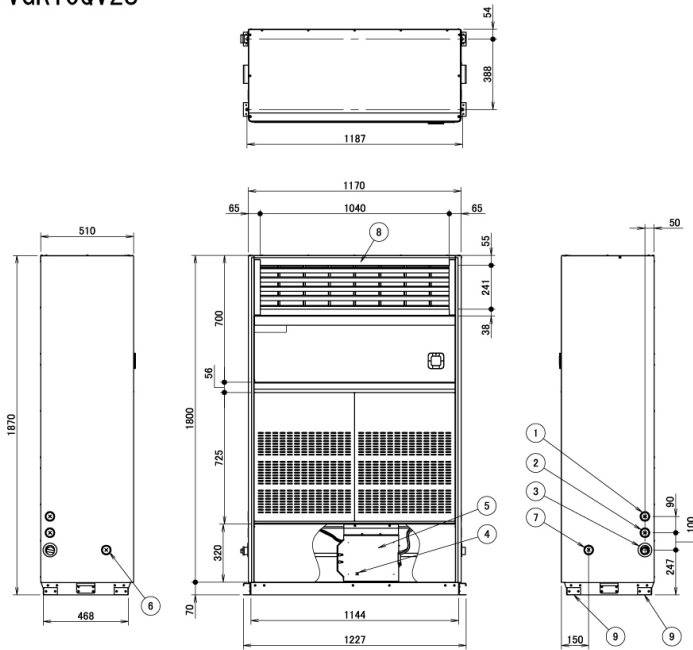

พื้นที่สำหรับซ่อมบำรุง หมายเหตุ 1)

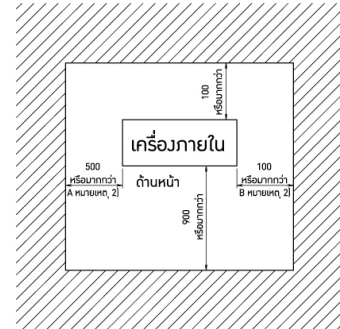

หมายเหตุ 1) แสดงกรณีเดินท่อด้านซ้าย  
(ถ้าเริ่มเดินจากโอบานคือกรณีเดินท่อด้านซ้าย ต้องปรับปริมาณบานอบ  
หากต้องการเปลี่ยนเป็นเดินท่อด้านขวา)  
2) ให้สังเกตขนาด A กับ B กรณีเดินท่อด้านขวา

9	สลักยึดฐาน	สำหรับโอบัด M12
8	หน้าแปลนด้านปล่อยลม	
7	จุดเชื่อมต่อสายรับ-ส่งสัญญาณ	
6	จุดเชื่อมต่อสายหม้อแปลงไฟ	
5	กล่องควบคุม	
4	ขั้วต่อสายดิน (ใช้ต่อในกล่องควบคุม)	M4
3	จุดเชื่อมต่อท่อน้ำทิ้ง	PS 1B เกสวาว
2	จุดเชื่อมต่อท่อก๊าซ	FVGR200/FVGR08 FVGR250/FVGR10
		φ 19.1 φ 22.2
1	จุดเชื่อมต่อท่อน้ำเหลว	φ 9.5
รายการ	ชื่ออุปกรณ์	รายละเอียด

3D150294

### DUCT CONNECTION

FVPR10QY2S

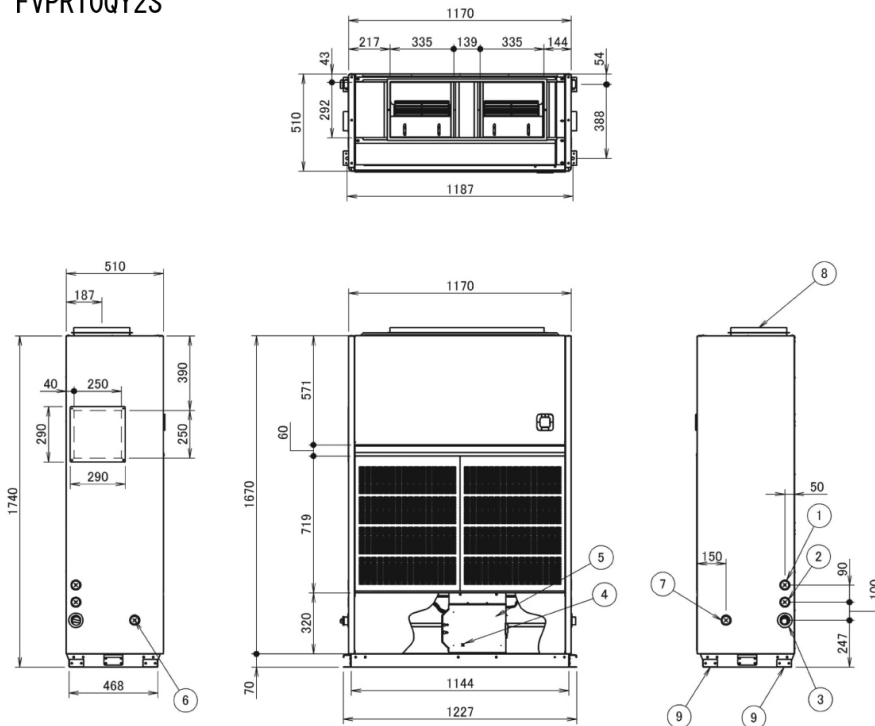

SERVICE SPACE NOTE 1)

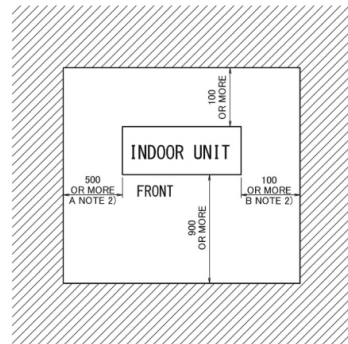

NOTE 1) IT SHOWS IN CASE OF LEFT SIDE PIPING.  
(FACTORY DEFAULT IS LEFT SIDE PIPING.  
CHANGE TO RIGHT SIDE PIPING NEEDS FIELD WORK.)  
2) REVERSE DIMENSION A TO B IN CASE OF RIGHT SIDE PIPING.

9	FOUNDATION BOLT	FOR M12 BOLT
8	AIR DISCHARGE FLANGE	
7	TRANSMISSION WIRING CONNECTION	
6	POWER SUPPLY WIRING CONNECTION	
5	CONTROL BOX	
4	EARTH TERMINAL (TERMINAL IN CONTROL BOX)	M4
3	DRAIN PIPE CONNECTION	PS 1B INTERNAL THREAD
2	GAS PIPE CONNECTION	φ 22.2
1	LIQUID PIPE CONNECTION	φ 9.5
ITEM	PART NAME	REMARK

3D147290A

## DUCT CONNECTION

FVPR12QY2S  
FVPR16QY2S

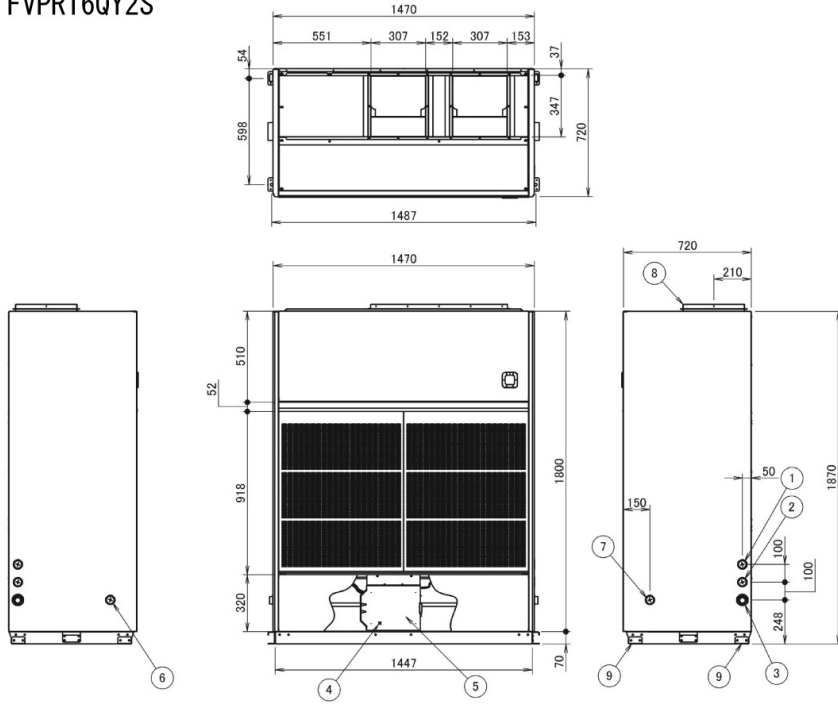

SERVICE SPACE NOTE 1)

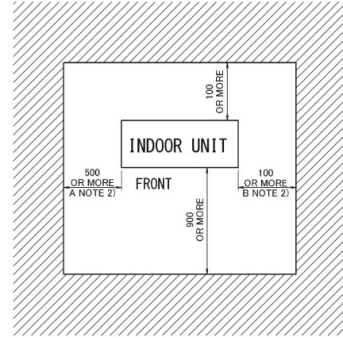

NOTE 1) IT SHOWS IN CASE OF LEFT SIDE PIPING.  
(FACTORY DEFAULT IS LEFT SIDE PIPING.  
CHANGE TO RIGHT SIDE PIPING NEEDS FIELD WORK.)  
2) REVERSE DIMENSION A TO B IN CASE OF RIGHT SIDE PIPING.

9	FOUNDATION BOLT	FOR M12 BOLT
8	AIR DISCHARGE FLANGE	
7	TRANSMISSION WIRING CONNECTION	
6	POWER SUPPLY WIRING CONNECTION	
5	CONTROL BOX	
4	EARTH TERMINAL (TERMINAL IN CONTROL BOX)	M4
3	DRAIN PIPE CONNECTION	PS 1B INTERNAL THREAD
2	GAS PIPE CONNECTION	φ 28.6
1	LIQUID PIPE CONNECTION	φ 12.7
ITEM	PART NAME	REMARK

3D147291A

## DUCT CONNECTION

FVPR18QY2S  
FVPR20QY2S

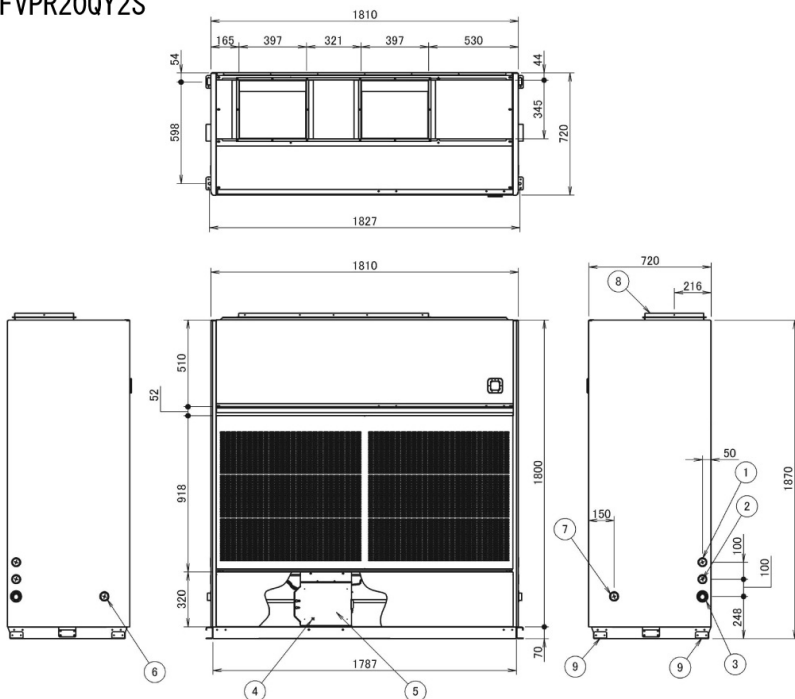

SERVICE SPACE NOTE 1)

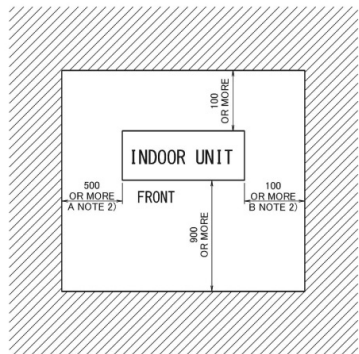

NOTE 1) IT SHOWS IN CASE OF LEFT SIDE PIPING.  
(FACTORY DEFAULT IS LEFT SIDE PIPING.  
CHANGE TO RIGHT SIDE PIPING NEEDS FIELD WORK.)  
2) REVERSE DIMENSION A TO B IN CASE OF RIGHT SIDE PIPING.

9	FOUNDATION BOLT	FOR M12 BOLT
8	AIR DISCHARGE FLANGE	
7	TRANSMISSION WIRING CONNECTION	
6	POWER SUPPLY WIRING CONNECTION	
5	CONTROL BOX	
4	EARTH TERMINAL (TERMINAL IN CONTROL BOX)	M4
3	DRAIN PIPE CONNECTION	PS 1B INTERNAL THREAD
2	GAS PIPE CONNECTION	φ 28.6
1	LIQUID PIPE CONNECTION	φ 15.9
ITEM	PART NAME	REMARK

3D147292A

# Dimensions (Unit:mm)

## DUCT TYPE

### FDR08/10QY2S

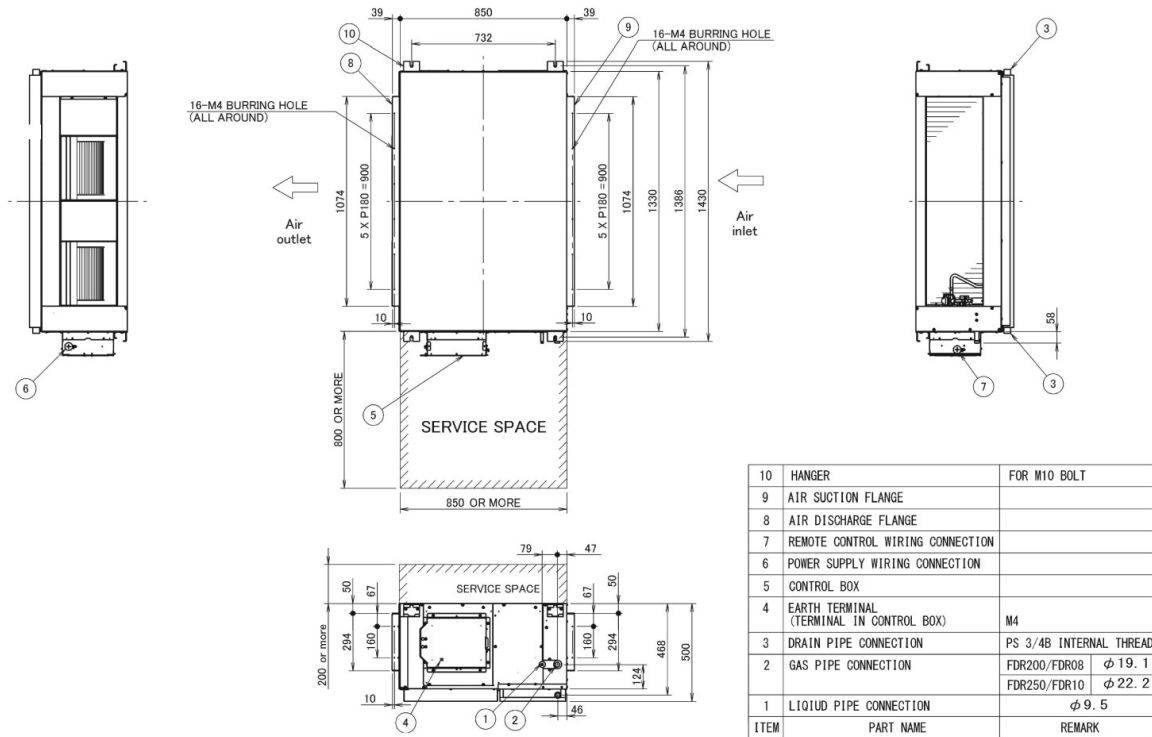

3D147287A

### FDR12/16QY2S

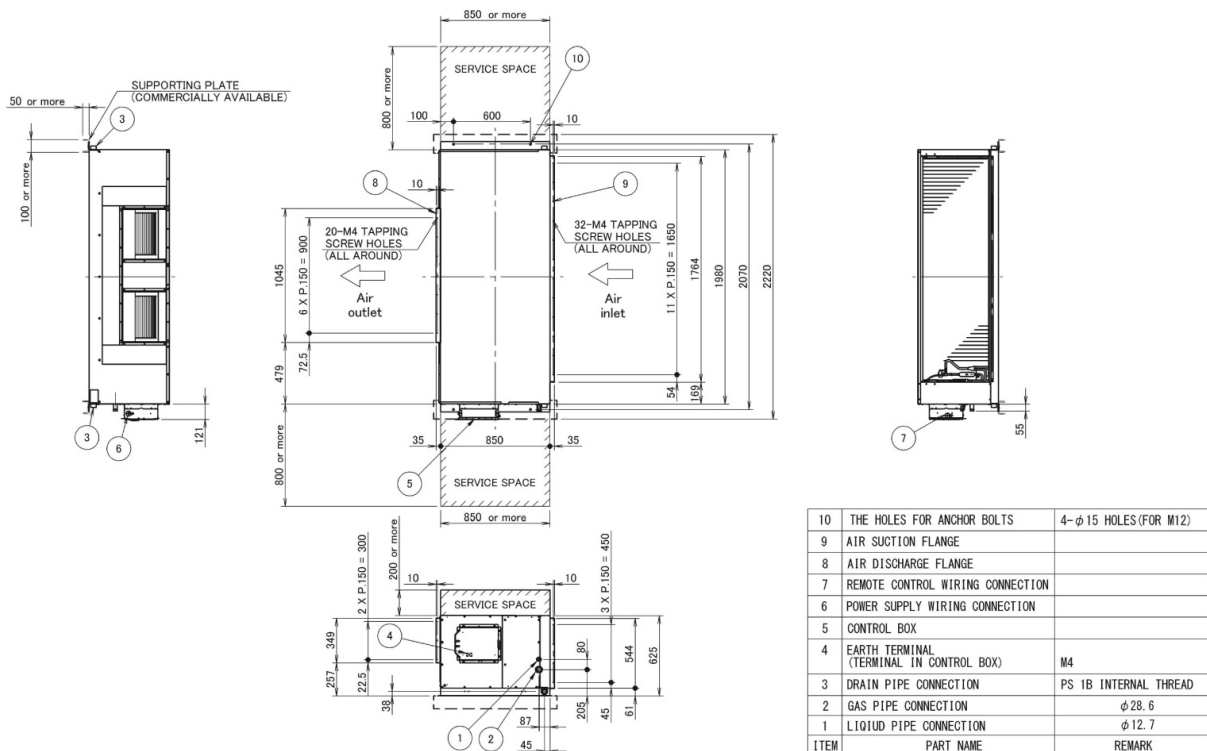

3D147288A

# FDR18/20QY2S

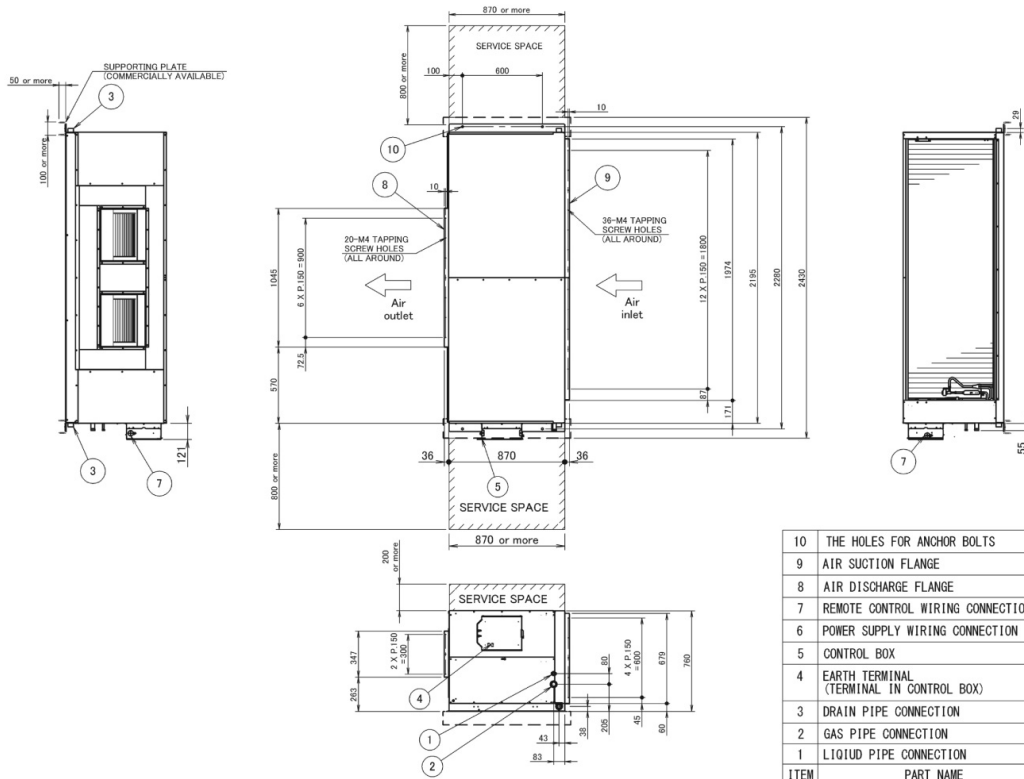

10	THE HOLES FOR ANCHOR BOLTS	4- $\phi$ 15 HOLES (FOR M12)
9	AIR SUCTION FLANGE	
8	AIR DISCHARGE FLANGE	
7	REMOTE CONTROL WIRING CONNECTION	
6	POWER SUPPLY WIRING CONNECTION	
5	CONTROL BOX	
4	EARTH TERMINAL (TERMINAL IN CONTROL BOX)	M4
3	DRAIN PIPE CONNECTION	PS 1B INTERNAL THREAD
2	GAS PIPE CONNECTION	$\phi$ 28.6
1	LIQUID PIPE CONNECTION	$\phi$ 15.9
ITEM	PART NAME	REMARK

3D147289A

# Dimensions (Unit:mm)

## OUTDOOR UNIT

### RZUR08QY2S

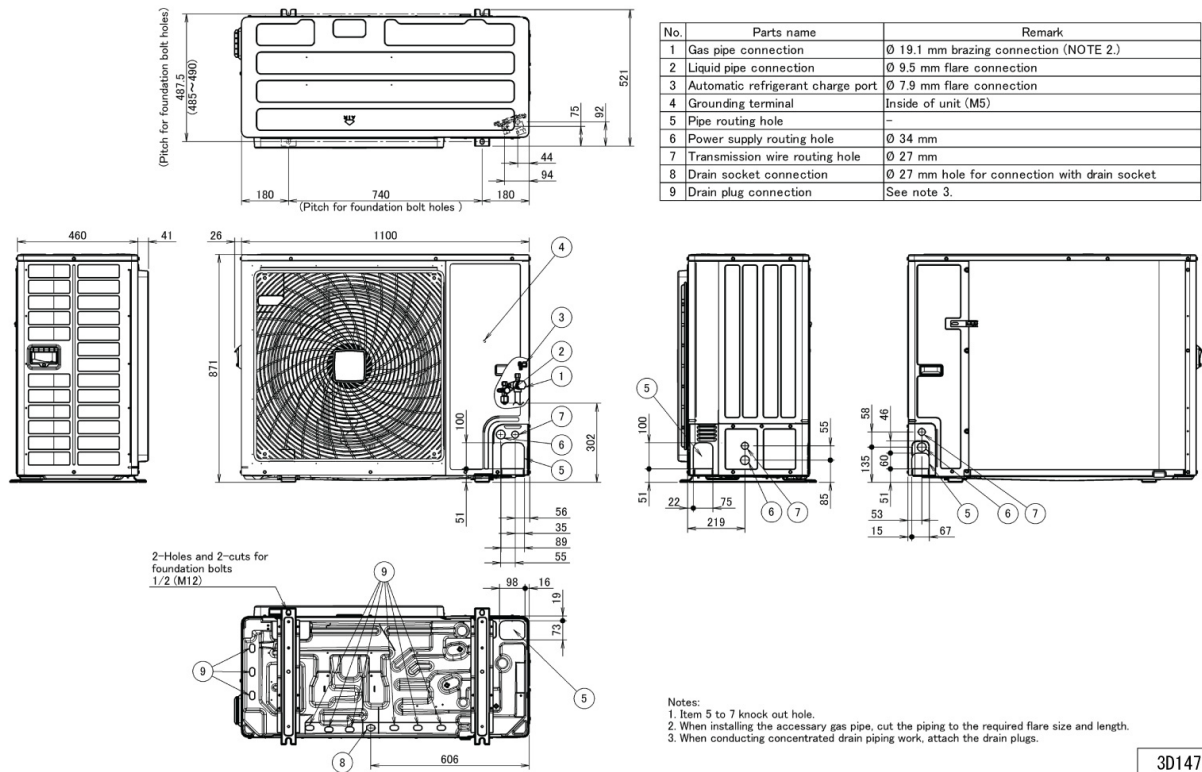

3D147199

### RZUR10QY2S

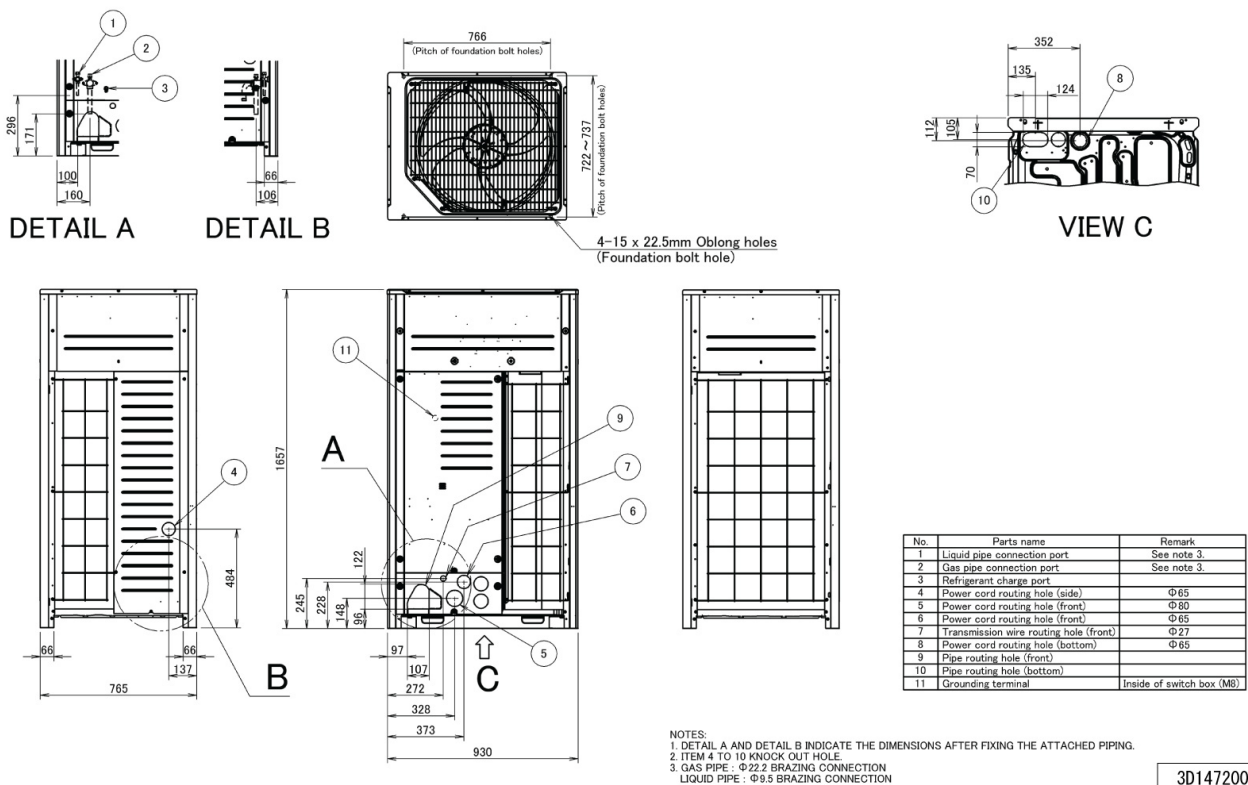

3D147200

# RZUR12/16/18/20QY2S

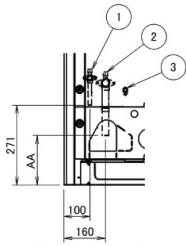

DETAIL A

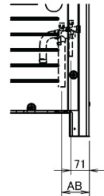

DETAIL B

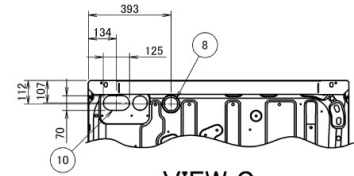
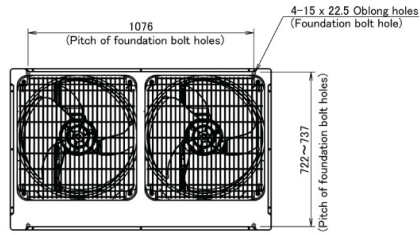

VIEW C

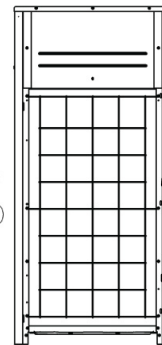
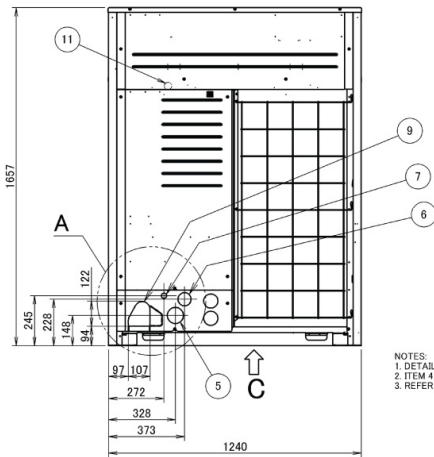
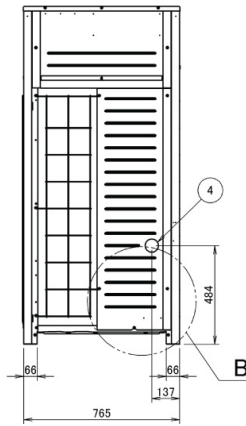

Model	AA	AB
RZUR300QY1(4) RZUR12QY2S	171	106
RZUR400,450,500QY1(4) RZUR16,18,20QY2S	161	101

No.	Parts name	Remark
1	Liquid pipe connection port	See note 3.
2	Gas pipe connection port	See note 3.
3	Refrigerant charge port	
4	Power cord routing hole (side)	Φ65
5	Power cord routing hole (front)	Φ80
6	Power cord routing hole (front)	Φ65
7	Transmission wire routing hole (front)	Φ27
8	Power cord routing hole (bottom)	Φ65
9	Pipe routing hole (front)	
10	Pipe routing hole (bottom)	
11	Grounding terminal	Inside of switch box (M8)

NOTES:  
1. DETAIL A AND DETAIL B INDICATE THE DIMENSIONS AFTER FIXING THE ATTACHED PIPING.  
2. ITEM 4 TO 10 KNOCK OUT HOLE.  
3. REFER THE PIPING CONNECTION FROM THE TABLE BELOW:

MODEL	LIQUID PIPE	GAS PIPE
RZUR300,400QY1(4) RZUR12,16QY2S	Φ12.7 BRAZING CONNECTION	Φ28.8 BRAZING CONNECTION
RZUR450,500QY1(4) RZUR18,20QY2S	Φ15.8 BRAZING CONNECTION	Φ28.8 BRAZING CONNECTION

3D147202

# Space required for indoor unit installation (Unit:mm)

FVGR08QV2S  
FVGR10QV2S

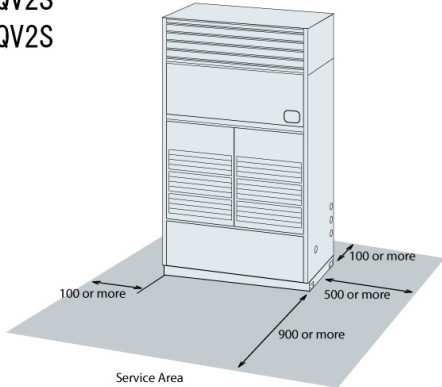

\* Incase of left side Piping

FVPR10QY2S  
FVPR12QY2S  
FVPR16QY2S  
FVPR18QY2S  
FVPR20QY2S

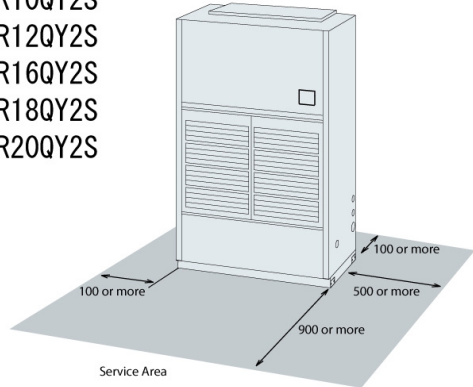

\* Incase of left side Piping

FDR08QY2S  
FDR10QY2S

Provide enough clearance between the unit and the surrounding walls to prevent contact.

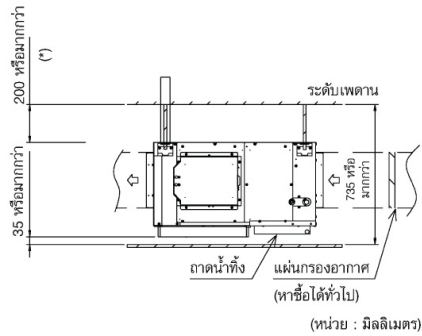
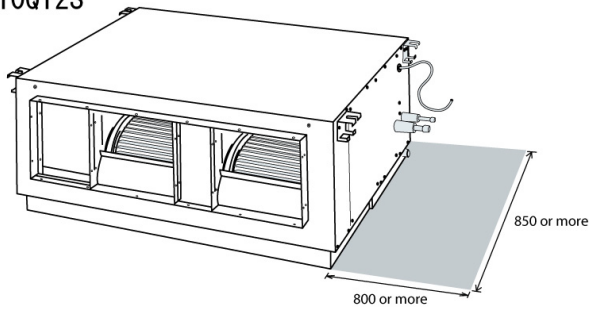

FDR12QY2S  
FDR16QY2S

Provide enough clearance between the unit and the surrounding walls to prevent contact.

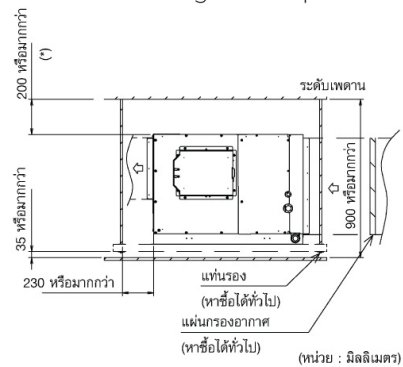
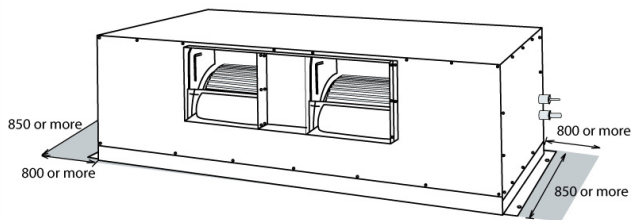

FDR18QY2S  
FDR20QY2S

Provide enough clearance between the unit and the surrounding walls to prevent contact.

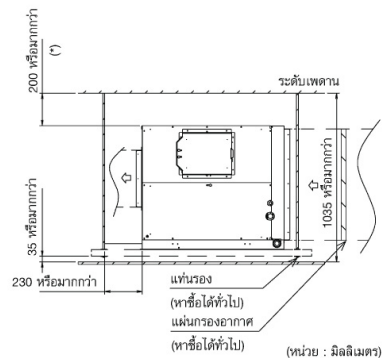
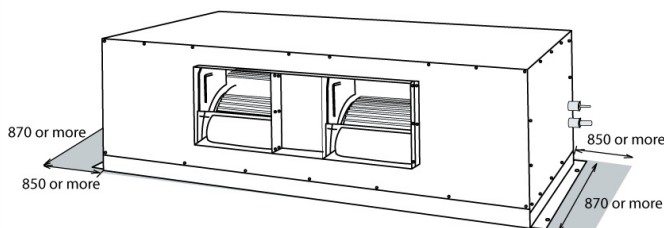

# Space required for outdoor unit installation (Unit:mm)

## RZUR08QY2S (Please refer to engineering databook for other installation patterns)

For side by side installation the connection piping is lead out from the front, the bottom and the side should keep the inter space over 100 mm. To lead out the piping from the back. The inter space over 250 mm. should be keep on the right side of the outdoor unit. The unit of the values is mm.

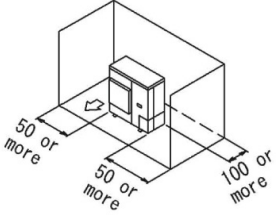
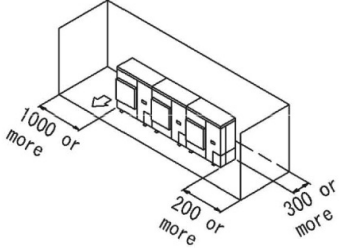
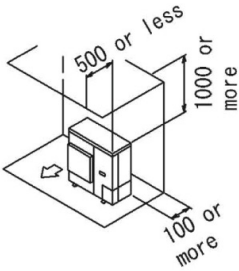
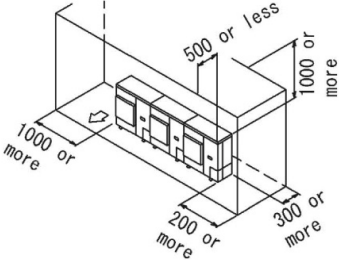
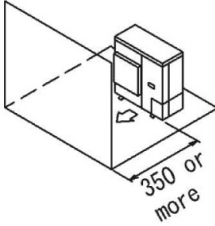
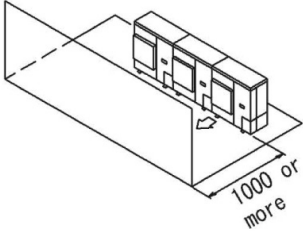
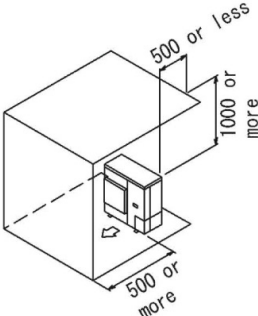
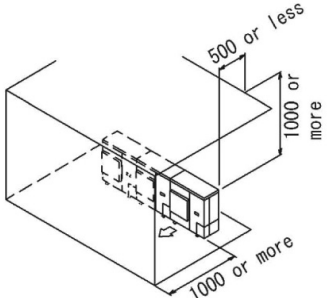
Obstacle	Single Unit Installation	Series Installation
Obstacle Suction Side + Both Side		
Obstacle Suction Side + Both Side + Above		
Obstacle Discharge Side		
Obstacle Discharge Side + Above		

# Space required for outdoor unit installation (Unit:mm)

RZUR10QY2S / RZUR12QY2S / RZUR16QY2S / RZUR18QY2S / RZUR20QY2S

## For single unit installation

Pattern 1

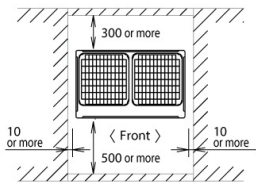

Pattern 2

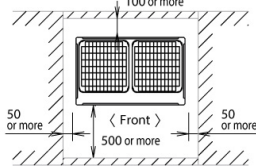

Pattern 3

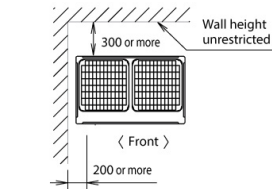

## For installation in rows

Pattern 1

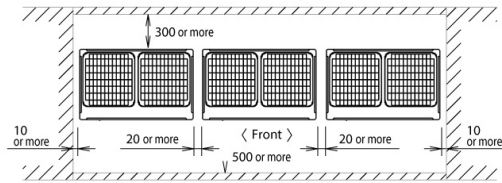

Pattern 2

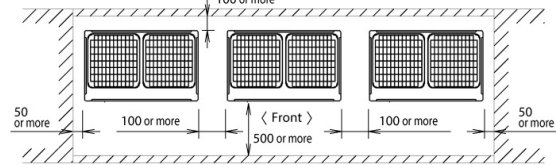

Pattern 3

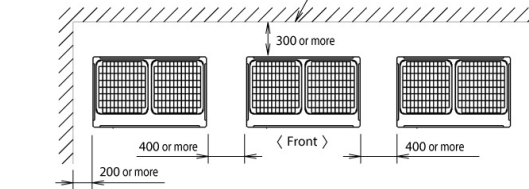

## For centralized group layout

Pattern 1

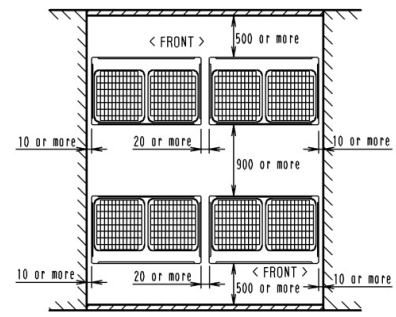
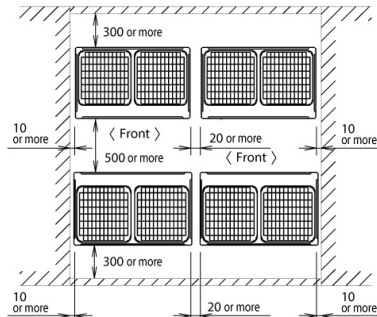
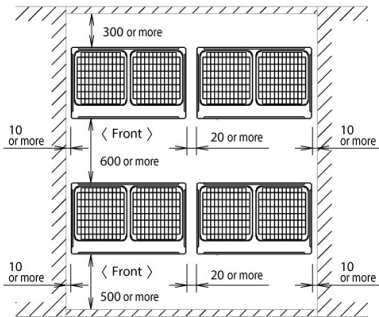

Pattern 2

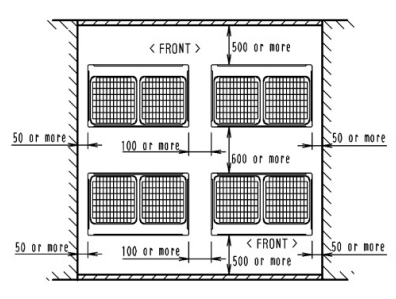
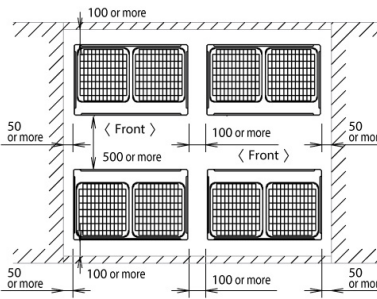
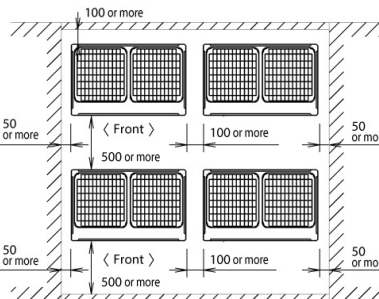

( Unit : mm )

Notes: 1. Heights of walls in case of Patterns 1 and 2:

Front : 1500 mm  
Suction side : 500 mm  
Side : Height unrestricted.

- Installation space to be shown in this drawing is based on the cooling operation at 35 degrees outdoor air temperature. When the design outdoor air temperature exceeds 35 degrees or the load exceeds maximum ability because of much generation load of heat in all outdoor unit, take the suction side space more broadly than the space to be shown in this drawing.
- If the above wall heights are exceeded then  $h_2/2$  and  $h_1/2$  should be added to the front and suction side service spaces respectively as shown in the figure on the right.
- When installing the units most appropriate pattern should be selected from those shown above in order to obtain the best fit in the space available always bearing in mind the need to leave enough space for a person to pass between units and wall and for the air to circulate freely.  
(If more units are to be installed than are catered for in the above patterns your layout should take account of the possibility of short circuits.)
- The units should be installed to leave sufficient space at the front for the on site refrigerant piping work to be carried out comfortably.

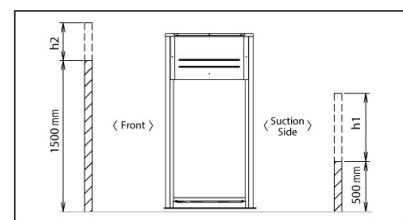

# Discharge grill Plenum Chamber

FLOOR STANDING TYPE

## BPCV10Q

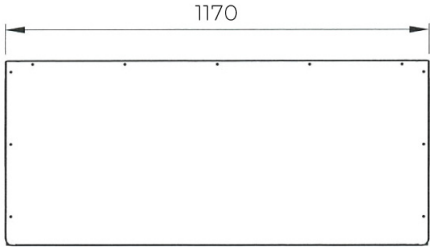
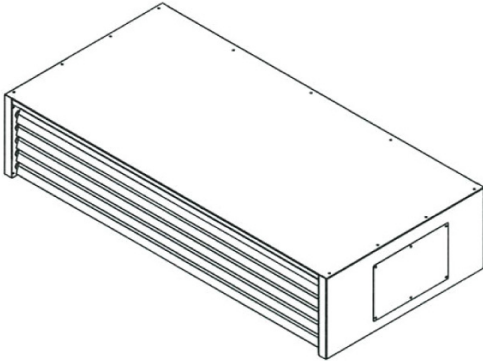

Top View



Front View

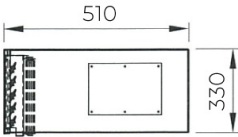

Side View

## BPCV16Q

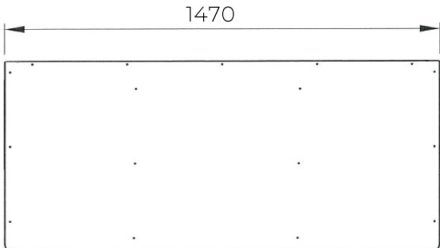
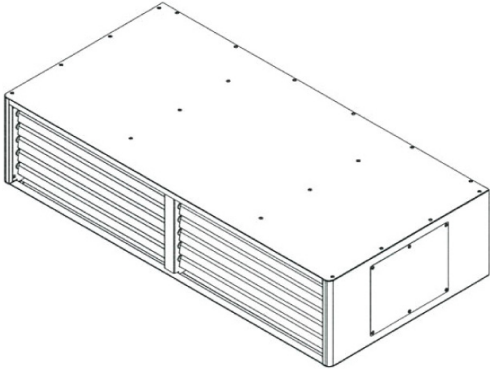

Top View

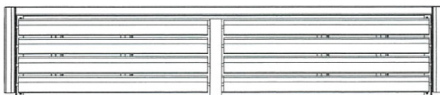

Front View

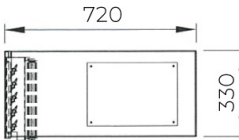

Side View

## BPCV20Q

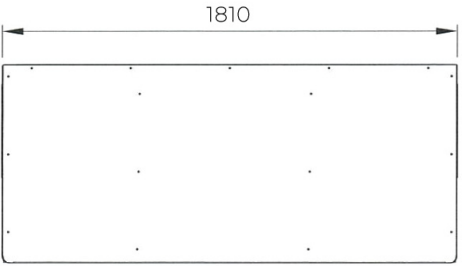
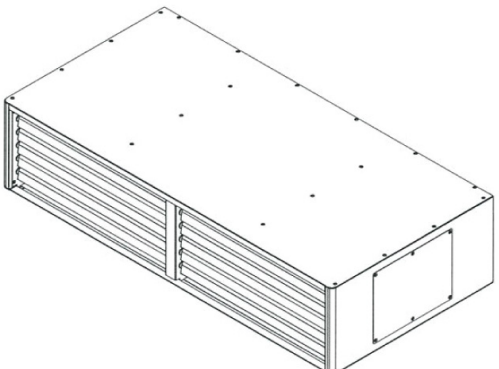

Top View



Front View

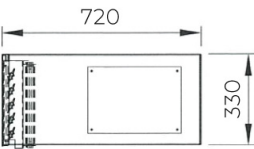

Side View

# Space required for outdoor unit installation (Unit:mm)

## DUCT TYPE

### BPCD10Q

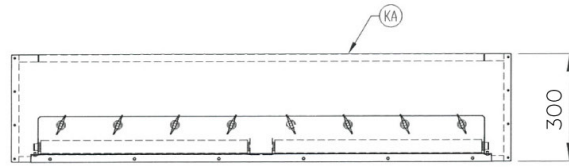
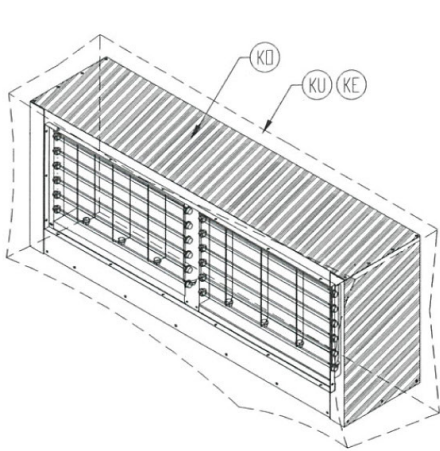

Top View

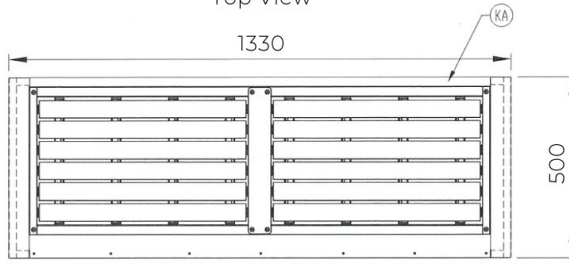

Front View

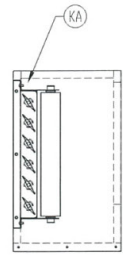

Side View

### BPCD16Q

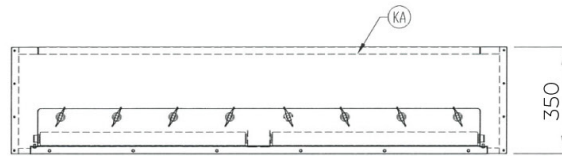
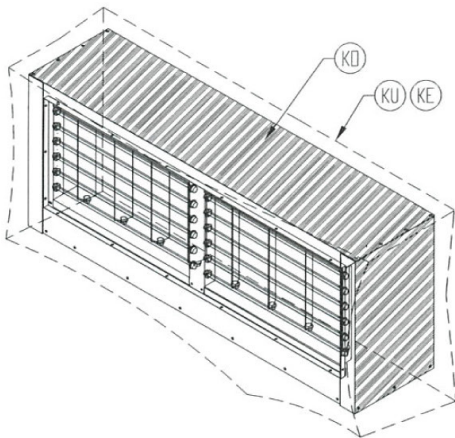

Top View

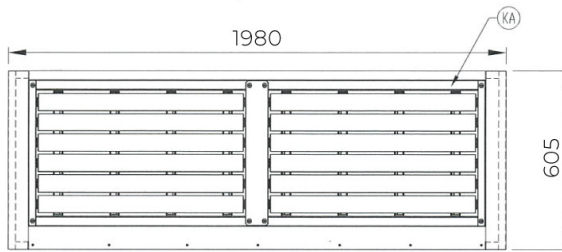

Front View

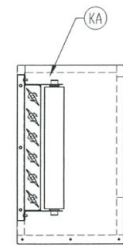

Side View

### BPCD20Q

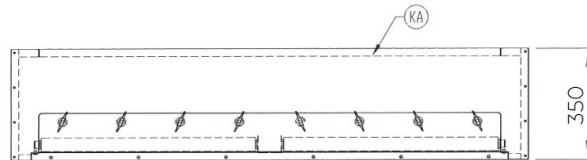
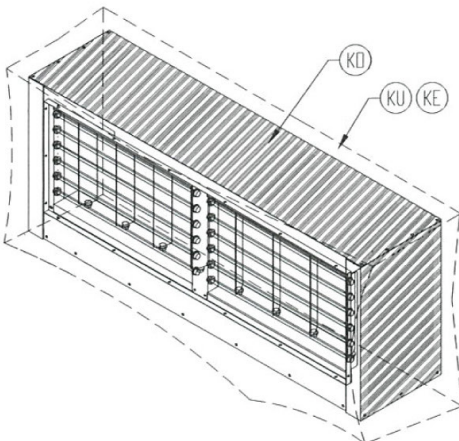

Top View

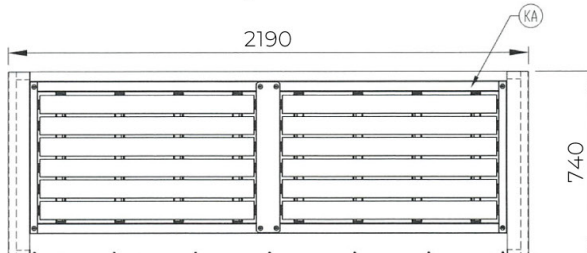

Front View

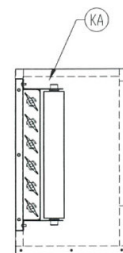

SideView



# MEMO





**Warning**

- Ask a qualified installer or contractor to install this product. Do not try to install the product yourself. Improper installation can result in water or refrigerant leakage, electrical shock, fire or explosion.
- Use only those parts and accessories supplied or specified by Daikin. Ask a qualified installer or contractor to install those parts and accessories. Use of unauthorised parts and accessories or improper installation of parts and accessories can result in water or refrigerant leakage, electrical shock, fire or explosion.
- Read the user's manual carefully before using this product. The user's manual provides important safety instructions and warnings. Be sure to follow these instructions and warnings.

**Notice**

- About harmonics, since this product is equipped with an inverter, harmonics will be generated. If local laws require the suppression of harmonics on the building, please take harmonic suppression measures on the electrical equipment side. Please contact your local sales company for details.

If you have any enquiries, please contact your local importer, distributor and/or retailer.

**Cautions on product corrosion**

1. Air conditioners should not be installed in areas where corrosive gases, such as acid gas or alkaline gas, are produced.
2. If the outdoor unit is to be installed close to the sea shore, direct exposure to the sea breeze should be avoided.  
If you need to install the outdoor unit close to the sea shore, contact your local distributor.

**SIAM DAIKIN SALES CO.,LTD.**

22 Soi Onnuch 55/1  
Pravet Subdistrict, Pravet District,  
Bangkok 10250

Tel. 0-2838-3200  
Fax. 0-2721-7607

