

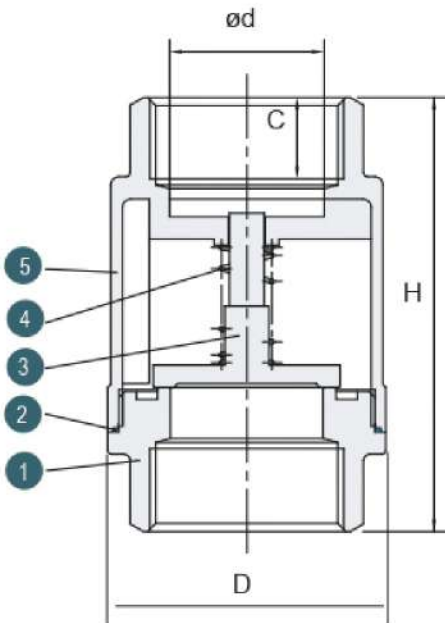

FEATURES :

- INVESTMENT CASTING BODY & CAP
- 800 PSI
- 2-PC DESIGN FULL PORT
- ALL KIND OF THREAD STANDARD AVAILABLE
- DESIGN STANDARD:ASME B16.34
- INSPECTION STANDARD :API598
- WORKING TEMPERATURE:-20°C ---200°C
- WORKING PRESSURE : 0.5--50 BAR



MATERIALS :

NO.	PART NAME	Qty	MATERIAL
1	CAP	1	CF8M
2	GASKET	1	PTFE
3	DISC	1	SUS316
4	SPRING	1	SUS316
5	BODY	1	CF8M

DIMENSIONS :

UNIT : mm

SIZE	d	H	D
1/2"	15	60	37
3/4"	20	67	42
1"	25	81	49
1 1/4"	32	91	58
1 1/2"	38	100	70
2"	48	107	83