



MODEL :

- C131 S45C A216Gr-WCB/DIN1.0619
- C134 S45C/A216Gr-WCB/DIN1.0619
- C133 SUS316 A351Gr-CF8M/DIN1.4408
- C136 SUS316 A351Gr-CF8M/DIN1.4408

FEATURES :

- PIPE THREAD IN ACCORDANCE:
- NPT,BSPT,DIN259,DIN2999,ISO 228 CLASS A
- BLOW-OUT PROOF STEM/FULL PORT
- INVESTMENT CASTING BODY
- 1000PSI(PN63)W.O.G.
- LOCKING DEVICE
- C131/C133 SCREWED TYPE
- C134/C136 SOCKET WELD TYPE

MATERIALS LIST :

ITEM	PART NAME	MATERIAL	
1	BODY	WCB	CF8M
2	CAP	WCB	CF8M
3	BALL	CF8M	
4	SEAT	PTFE	
5	STEM	SUS316	
6	GASKET	PTFE	
7	THRUST WASHER	PTFE	
8	PACKING	PTFE	
9	WASHER	SUS304	
10	SPRING WASHER	SUS304	
11	STEM NUT	SUS304	
12	LOCKING DEVICE	SUS304	
13	HANDLE	SUS304	
14	PLASTIC COVER	PLASTIC	
15	HEX NUT	SUS304	
16	BOLT WASHER	SUS304	
17	JOINT BOLT	SUS304	

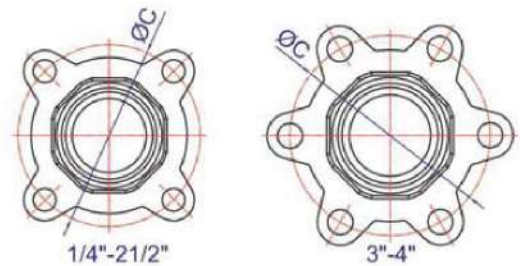
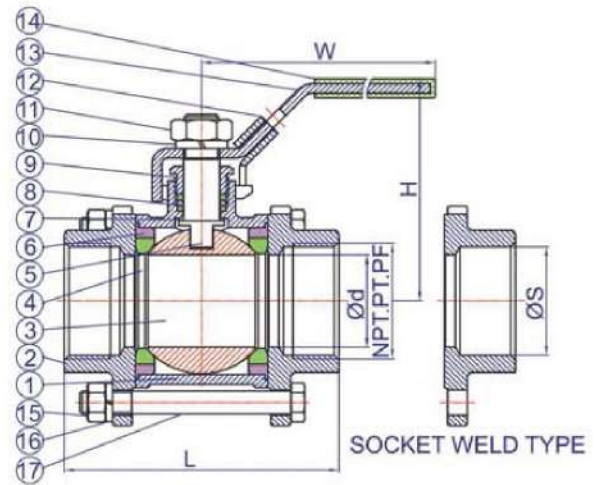

DIMENSIONS :

size		d	L	H	W	C	S	CV FACTOR	TORQUE N.M
DN	NPS								
8	1/4"	11.6	58	56	102	40.5	14.1	6	4.2
10	3/8"	12.7	58	56	102	40.5	17.6	7	4.2
15	1/2"	15	63	65	123	47	21.7	10	7.0
20	3/4"	20	73	67	123	53.5	27.1	25	9.0
25	1"	25	85	79	153	59.6	33.8	35	12.4
32	1 1/4"	32	96	84	153	74.2	42.6	46	15
40	1 1/2"	38	114	92	183	84	48.7	80	20
50	2"	50	134	99	183	101	61.1	110	30
65	2 1/2"	65	180	136	246	132	76.9	310	42
80	3"	80	200	146	246	161.5	89.8	360	65
100	4"	100	228	168	503	191	115.5	820	100

