



### FEATURES :

- BUTT WELD END CAP:ISO1127,DIN2463, ASME B36.9
- FACE TO FACE:DIN3202-S13
- BLOW-OUT PROOF STEM/FULL PORT
- SCREWED END/SOCKET WELD END
- WITH ISO5211 DIRECT MOUNTING PAD
- INVESTMENT CASTING BODY
- 1000PSI(PN63)W.O.G.
- LOCKING DEVICE

### MATERIALS LIST :

NO.	PART NAME	MATERIAL	
1	BODY	WCB	CF8M
2	CAP	WCB	CF8M
3	BALL	CF8M	
4	SEAT	PTFE	
5	STEM	SUS316	
6	GASKET	PTFE	
7	THRUST WASHER	15%R+PTFE	
8	O-RING	VITON	
9	PACKING	PTFE	
10	GLAND	SUS304	
11	SPRING WASHER	SUS304	
12	STEM NUT	SUS304	
13	STOP WASHER	SUS304	
14	HANDLE WASHER	SUS304	
15	LOCKING DEVICE	SUS304	
16	HANDLE	SUS304	
17	PLASTIC COVER	PLASTIC	
18	HEX NUT	SUS304	
19	BOLT WASHER	SUS304	
20	JOINT BOLT	SUS304	
21	STOP PIN	SUS304	

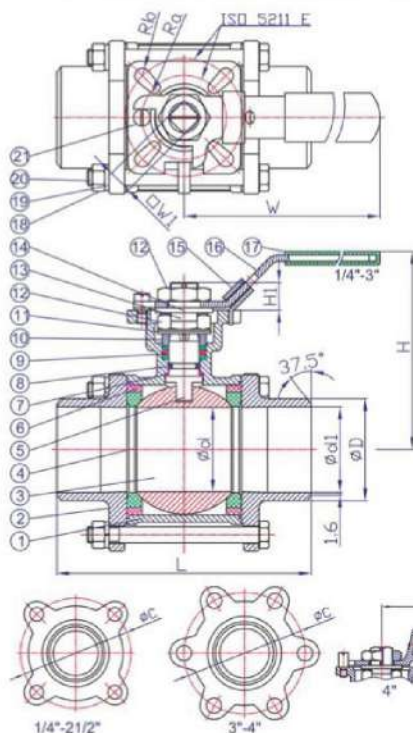
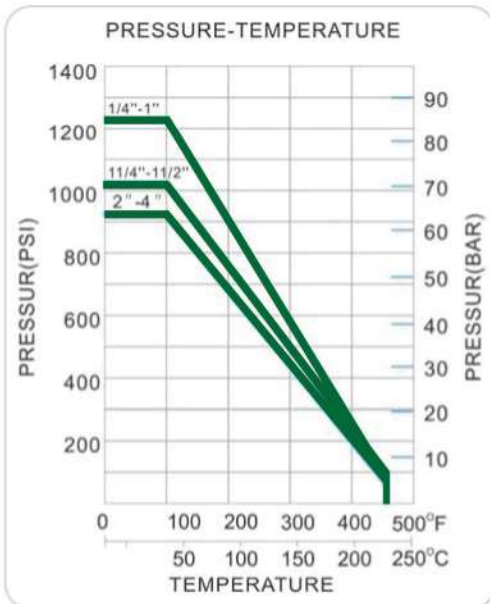

### DIMENSIONS :

size		d	d1	L	H	W	C	D	ISO 5211 E	H1	W1	Ra	Rb	CV FACTOR	TORQUE N.M
DN	NPS														
8	1/4"	11.6	10.0	70	74	123	52.0	17.2	F03-F04	9	9	R3	R3	6	6
10	3/8"	12.7	12.5	70	74	123	52.0	17.2	F03-F04	9	9	R3	R3	7	6
15	1/2"	15	16.0	75	74	123	52.0	31.3	F03-F04	9	9	R3	R3	10	12
20	3/4"	20	20.0	90	78	123	54.5	26.7	F03-F04	9	9	R3	R3	25	15
25	1"	25	25.0	100	89	153	63.5	33.6	F04-F05	11	11	R3	R3.5	35	18
32	1 1/4"	32	33.8	110	94	153	74.2	42.4	F04-F05	11	11	R3	R3.5	46	20
40	1 1/2"	38	39.5	125	110	183	84.0	48.0	F05-F07	14	14	R3.5	R4.5	80	35
50	2"	50	50.8	150	118	183	101	60.5	F05-F07	14	14	R3.5	R4.5	110	48
65	2 1/2"	65	62.7	190	161	246	132	76.1	F07-F10	17	17	R4.5	R5.5	310	55
80	3"	80	77.9	220	170	246	161.5	88.9	F07-F10	17	17	R4.5	R5.5	360	85
100	4"	100	100	270	202	395	191	114.2	F10-F12	22	22	R5.7	R6.7	820	110