



MODEL :

- C221 CAST IRON/A126Gr-FC20-JIS-10K
- C222 CARBON STEEL WCB-JIS-10K
- C223 STAINLESS STEEL 304/SCS13-JIS-10K
- C224 STAINLESS STEEL 316/SCS14-JIS-10K

FEATURES :

- FACE TO FACE DIMENSIONS: JIS B2002
- END FLANGE DIMENSIONS: JIS B2239
- DESIGN: ANSI 16.34
- TEST: JIS B2203
- WITH ISO 5211 MOUNTING PAD
- INVESTMENT CASTING BODY
- BLOW-OUT PROOF STEM / FULL BORE
- LEVER OPERATED OR GEAR OPERATED

MATERIALS LIST :

| ITEM | PART NAME | MATERIALS | | | |
|------|---------------|-----------|--------|--------|--------|
| | | FC20 | WCB | SCS13 | SCS14 |
| 1 | BODY | FC20 | WCB | SCS13 | SCS14 |
| 2 | CAP | FC20 | WCB | SCS13 | SCS14 |
| 3 | BALL | SCS13 | SCS13 | SCS13 | SCS14 |
| 4 | SEAT | TFM | | | |
| 5 | STEM | SUS304 | SUS304 | SUS304 | SUS316 |
| 6 | GASKET | TFM | | | |
| 7 | THRUST WASHER | TFM | | | |
| 8 | PACKING | TFM | | | |
| 9 | STEM PACKING | TFM | | | |
| 10 | GLAND | SUS13 | | | |
| 11 | GLAND BOLT | SUS304 | | | |
| 12 | HANDLE | WCB | | | |
| 13 | STOPPER | SUS304 | | | |
| 14 | SNAP RING | SUS304 | | | |
| 15 | BOLT | SUS304 | | | |
| 16 | HANDLE BOLT | SUS304 | | | |
| 17 | PLASTIC COVER | PLASTIC | | | |

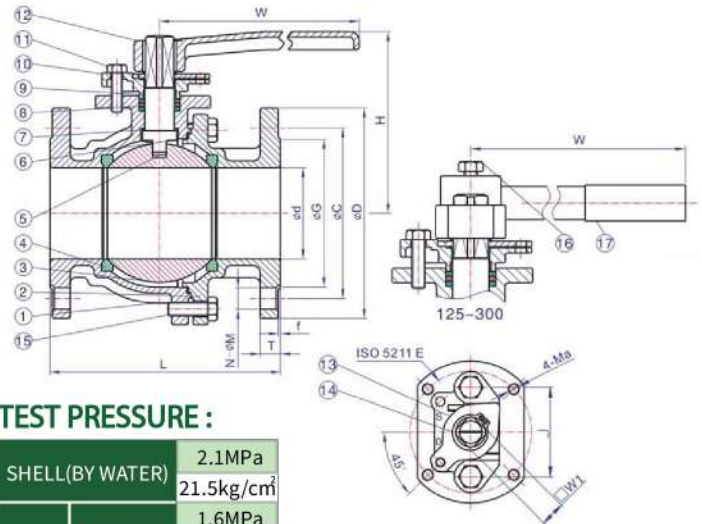

TEST PRESSURE :

| | | |
|------------------|------------------------|------------------------|
| SHELL (BY WATER) | 2.1MPa | |
| | 21.5kg/cm ² | |
| SEAT | BY WATER | 1.6MPa |
| | | 16.5kg/cm ² |
| | BY AIR | 0.6MPa |
| | | 6kg/cm ² |

DIMENSIONS :

| SIZE | d | D | C | G | f | T | | N-ØM | L | H | W | W1 | J | ISO 5211 | E | Ma |
|--------|-----|-----|-----|-----|---|----|-----|--------|-----|-----|------|----|-----|----------|-----|-----|
| | | | | | | FC | SUS | | | | | | | | | |
| 1/2" | 15 | 95 | 70 | 51 | 1 | 16 | 12 | 4-Ø15 | 110 | 70 | 160 | 12 | 50 | F04 | 42 | M5 |
| 3/4" | 20 | 100 | 75 | 56 | 1 | 18 | 14 | 4-Ø15 | 120 | 73 | 160 | 12 | 50 | F04 | 42 | M5 |
| 1" | 25 | 125 | 90 | 67 | 1 | 18 | 14 | 4-Ø19 | 130 | 77 | 160 | 12 | 50 | 04 | 42 | M5 |
| 1-1/4" | 32 | 135 | 100 | 76 | 2 | 20 | 16 | 4-Ø19 | 140 | 85 | 160 | 12 | 50 | F05 | 50 | M6 |
| 1-1/2" | 40 | 140 | 105 | 81 | 2 | 20 | 16 | 4-Ø19 | 165 | 104 | 186 | 17 | 62 | F07 | 70 | M8 |
| 2" | 50 | 155 | 120 | 96 | 2 | 20 | 16 | 4-Ø19 | 180 | 114 | 186 | 17 | 62 | F07 | 70 | M8 |
| 2-1/2" | 65 | 175 | 140 | 116 | 2 | 22 | 18 | 4-Ø19 | 190 | 142 | 324 | 21 | 75 | F07 | 70 | M8 |
| 3" | 80 | 185 | 150 | 126 | 2 | 22 | 18 | 8-Ø19 | 200 | 153 | 324 | 21 | 75 | F10 | 102 | M10 |
| 4" | 98 | 210 | 175 | 151 | 2 | 24 | 18 | 8-Ø19 | 230 | 166 | 324 | 21 | 75 | F10 | 102 | M10 |
| 5" | 125 | 250 | 210 | 182 | 2 | 24 | 20 | 8-Ø23 | 300 | 224 | 750 | 24 | 89 | F12 | 125 | M12 |
| 6" | 150 | 280 | 240 | 212 | 2 | 26 | 22 | 8-Ø23 | 340 | 247 | 750 | 24 | 89 | F12 | 125 | M12 |
| 8" | 198 | 330 | 290 | 262 | 2 | 26 | 22 | 12-Ø23 | 450 | 305 | 1000 | 32 | 100 | F12 | 125 | M12 |
| 10" | 250 | 400 | 355 | 324 | 2 | 30 | 24 | 12-Ø25 | 530 | 327 | 1000 | 32 | 100 | F14 | 140 | M16 |
| 12" | 300 | 445 | 400 | 368 | 3 | 32 | 24 | 16-Ø25 | 610 | 355 | 1000 | 32 | 100 | F14 | 140 | M16 |