

RESILIENT SEAT BUTTERFLY VALVE



Fig. BFV100L - WAFER Cast Iron Body Lever Operated
BFV100G - WAFER Cast Iron Body Gear Operated

Butterfly valves of KISTLER's design is apparent which utilize the phenolic-backed cartridge seat. These valves feature precision machined parts insuring years of dependable operation. With many body/trim combinations. The design can be suitable for BS/DIN/ANSI/JIS/UNI standard, etc. There are coating epoxy paint of 200um.

FEATURE

1. Small in size, light in weight. Easy installation & maintenance.
2. Simple and compact construction, quick 90 degrees on-off operation. Minimized operating torque, energy saving.
3. Long service life. Bubble-tight sealing with no leakage under the pressure test.
4. One piece shaft design ensures rigidity and stability of the shaft or disc assembly and minimize disc stress.
5. The operator top flange conforms to ISO5211 which Electric or Pneumatic actuator that have ISO5211 flange can be directly mounted.

MATERIALS

PART NAME	STANDARD MATERIALS
Body	Cast Iron (A126 Class B)
Disc	SUS 304 (CF8) , SUS 316 (CF8M)
Seat	EPDM , Buna-N (NBR)
Stem	Stainless Steel ASTM 410
Pin	SUS 316 (CF8M)
O-Ring	EPDM , Buna-N (NBR)
Bushing	PTFE

PERFORMANCE

NOMINAL DIAMETER	2" - 12" (50 - 300mm)	14" - 40" (350 - 1000mm)
Max.Working Pressure	16 bar (232 psi.)	10 bar (150 psi.)
Max.Working Temperature	NBR - 10°C + 80°C	
	EPDM - 10°C + 120°C	
	PTFE - 10°C + 150°C	
Testing Pressure	Body 24 bar (348 psi.)	15 bar (218 psi.)
	Seat 17.6 bar (255 psi.)	11 bar (160 psi.)

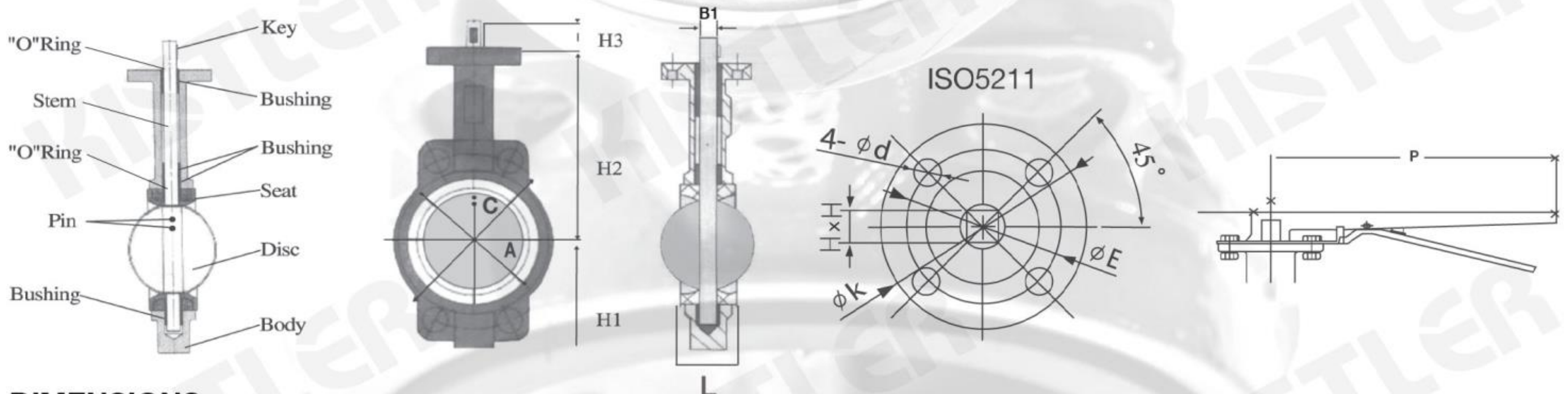

DIMENSIONS

Unit : mm.

DN(mm)	INCH	L	H1	H2	H3 L / G	B1	ISO5211	φE	φK	4-φd	P	C
50	2"	42.0	80	140	30/32	11	F07	70	90	4-19	266	
65	2.1/2"	44.7	89	150	30/32	11	F07	70	90	4-19	266	
80	3"	45.2	95	158	30/32	11	F07	70	90	4-19	266	This dimension
100	4"	52.0	114	176	30/32	11	F07	70	90	4-19	266	can be acc to BS5155,
125	5"	54.4	127	190	30/32	14	F07	70	90	4-23	266	ANSI 125/150,
150	6"	55.8	139	211	30/32	14	F07	70	90	4-23	266	DIN PN10/PN16,
200	8"	60.6	175	235	40/45	17	F10	102	125	4-23	355	JIS10K, UNI standard, etc.
250	10"	65.6	203	265	- /45	22	F10	102	125	4-25.4	Gear	
300	12"	76.9	242	305	- /45	22	F10	102	125	4-25.4	Gear	
350	14"	76.5	267	368	- /45	22	F10	102	125	4-28.4	Gear	
400	16"	102.0	321	405	- /52	27	F14	140	175	4-28.4	Gear	
450	18"	114.0	328	422	- /52	27	F14	140	175	4-31.8	Gear	
500	20"	127.0	361	480	- /65	36	F14	140	175	4-31.8	Gear	
600	24"	152.0	459	562	- /70	36	F16	165	210	20-35.1	Gear	