

**Stop valve - straight through with flanges and bellows seal (Grey cast iron, SG iron, Cast steel)**

Figure-No.	Nominal pressure	Material	Nominal diameter
12.046	PN16	EN-JL1040	DN15-300
22.046	PN16	EN-JS1049	DN15-350
	Test: • DIN DVGW-Reg. NG-4313AO 0772		
23.046	PN25	EN-JS1049	DN15-150
34.046	PN25	1.0619+N	DN200-400
35.046	PN40	1.0619+N	DN15-250

Test: • EN ISO 15848-1 / TA - Luft TÜV-Test-No. TA 07 2016 C04

Considered standards: • EN 13709 (1.0619+N)  
• EN 13789 (EN-JL1040, EN-JS1049)

Plug design: • Plug with marginal seat standard

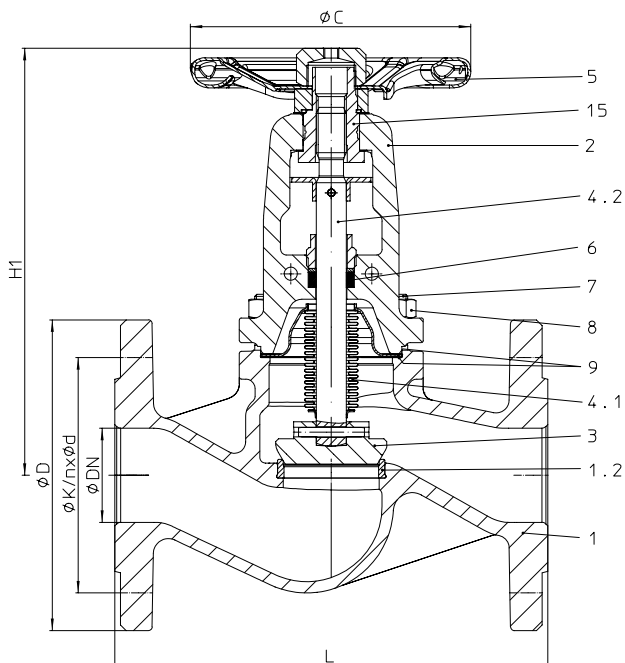
**At high differential pressures a balancing plug is necessary!** (refer to page 12)

Parts					
Pos.	Sp.p.	Description	Fig. 12.046	Fig. 22. / 23.046	Fig. 34. / 35.046
1		Body	EN-JL1040, EN-GJL-250	EN-JS1049, EN-GJS-400-18U-LT	GP240GH+N, 1.0619+N
1.2		Seat ring	X20Cr13+QT, 1.4021+QT		≤DN50: X20Cr13+QT, 1.4021+QT / ≥DN65: G19 9 NbSi, 1.4551
2		Bonnet	EN-JS1049, EN-GJS-400-18U-LT		GP240GH+N, 1.0619+N
3	x	Plug	≤ DN200: X20Cr13+QT, 1.4021+QT (hardened) / ≥ DN250: P265GH, 1.0425 / Stellite 21		
4		Spindle unit	--		
4.1	x	Bellows seal	X6CrNiMoTi17 12 2, 1.4571		
4.2		Stem	X20Cr13+QT, 1.4021+QT		
5		Handwheel	≤DN125: St (cataphoretic coating) / ≥DN150: EN-JL1040, EN-GJL-250 (epoxy-coating)		
6	x	Packing ring	Pure graphite		
7		Hexagon bolt	5.6	--	
7		Stud	--	25CrMo4, 1.7218	
8		Hexagon nut	--	C35E, 1.1181	
9	x	Gasket	Pure graphite (CrNi laminated with graphite)		
15	x	Insert nuts	11SMn30+C, 1.0715+C		
L Spare parts					

DN	15	20	25	32	40	50	65	80	100	125	150	200	250	300	350	400
----	----	----	----	----	----	----	----	----	-----	-----	-----	-----	-----	-----	-----	-----

Face-to-face dimension FTF series 1 acc. to DIN EN 558																	
L	(mm)	130	150	160	180	200	230	290	310	350	400	480	600	730	850	980	1100

Dimensions		Standard-flange dimensions refer to page 14																
H1	(mm)	205	205	210	210	225	230	245	265	365	395	430	550	720	775	975	1015	
ØC	PN16	(mm)	125	125	125	125	150	150	175	175	225	300	400	520	520	520	640	640
	PN25	(mm)	125	125	125	125	150	150	175	175	300	300	400	520	520	520	640	640
	PN40	(mm)	125	125	125	125	150	150	175	225	300	300	400	520	520	--	--	--
Travel	(mm)	6	6	8	8	13	13	16	20	25	32	40	50	70	80	90	100	
Kvs-value	(m³/h)	5,3	7,2	12	16	28,5	43	75	105	170	270	405	675	1090	1460	2010	2640	
Zeta-value	--	2,9	4,9	4,3	6,5	5	5,4	5,1	5,9	5,5	5,3	4,9	5,6	5,2	6,1	5,9	5,9	

Weights																	
12. / 22. / 23.046	(kg)	3,7	4,5	5,6	6,9	8,9	11	15,3	21,1	32,4	51,6	74	147	247	404	524	--
34.046	(kg)	--	--	--	--	--	--	--	--	--	--	--	168	268	395	629	865
35.046	(kg)	4,1	5,1	6,2	7,3	10,6	12,6	19,1	26,1	35	60,3	88	160	310	--	--	--

Information / restriction of technical rules need to be observed!

Operating and installation instructions can be downloaded at [www.ari-armaturen.com](http://www.ari-armaturen.com).

ARI-Valves of EN-JL1040 are not allowed to be operated in systems acc. to TRD 110.

A production allowance acc. to TRB 801 No. 45 exists (acc. to TRB 801 No. 45 EN-JL1040 is not allowed.)

The engineer, designing a system or a plant, is responsible for the selection of the correct valve.

Resistance and fitness must be verified (contact manufacturer for information, refer to Product overview and Resistance list).