

Strainer - Y-pattern with flanges (Grey cast iron, SG iron, Cast steel)

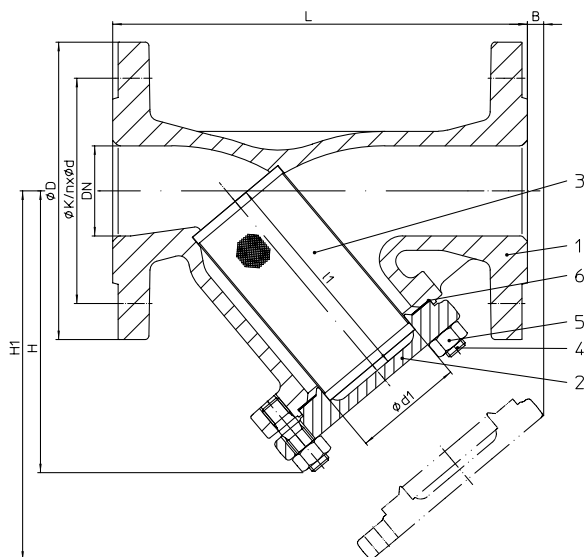

Figure	Nominal pressure	Material	Nominal diameter
10.050	PN6	EN-JL1040	DN15-200
12.050	PN16	EN-JL1040	DN15-300
22.050	PN16	EN-JS1049	DN15-300
23.050	PN25	EN-JS1049	DN15-150
34.050	PN25	1.0619+N	DN15-200
35.050	PN40	1.0619+N	DN15-200

A supporting basket is necessary, with higher differential pressures, dependent on clogging-up (DN >125 standard)

Test: • EN ISO 15848-1 / TA - Luft TÜV-Test-No. TA 09 2016 C04

Parts					
Pos.	Sp.p.	Description	Fig. 10./12.050	Fig. 22./23.050	Fig. 34./35.050
1		Body	EN-JL1040, EN-GJL-250	EN-JS1049, EN-GJS-400-18U-LT	GP240GH+N, 1.0619+N
2		Cover	DN ≤150: EN-JL1040, EN-GJL-250 DN >150: P265 GH, 1.0425	DN ≤80: EN-JS1049, EN-GJS-400-18U-LT DN >80: P265 GH, 1.0425	DN ≤80: P250 GH, 1.0460 DN >80: P265 GH, 1.0425
3	x	Screen	X5CrNi18-10, 1.4301		
3.1		Supporting basket	DN >125: X5CrNi18-10, 1.4301		
4		Stud	25CrMo4, 1.7218		
5		Hexagon nut	C35E, 1.1181		
6	x	Gasket	Pure graphite (CrNi laminated with graphite)		
L Spare parts					

DN	15	20	25	32	40	50	65	80	100	125	150	200	250	300	350	400	500
----	----	----	----	----	----	----	----	----	-----	-----	-----	-----	-----	-----	-----	-----	-----

Face-to-face dimension FTF series 1 according to DIN EN 558																Standard-flange dimensions refer to page 6		
L	(mm)	130	150	160	180	200	230	290	310	350	400	480	600	730	850			

Dimensions																
H	(mm)	90	100	115	125	150	160	180	215	235	275	305	390	540	680	
H1	(mm)	135	150	180	205	235	250	285	330	365	425	480	610	915	1110	
B	(mm)	10	10	25	35	45	45	25	40	55	65	50	80	230	350	
l1	(mm)	56	68	82	98	114	119	134	149	169	199	224	284	434	555	
Ød1	(mm)	23	28	36	42	50	61,5	78,5	89,5	109,5	137,5	160	210	258	308	
Standard screen	Mesh width	(mm)	1	1	1	1	1	1,25	1,25	1,6	1,6	1,6	1,6	1,6	1,6	
	Kvs-value ¹⁾	(m³/h)	6,9	10,8	17,8	26,1	36,7	61	98,6	146	234	376	394	652	1225	1873
	Zeta-value	--	1,7	2,2	2	2,5	3	2,7	2,9	3,1	2,9	2,8	5,2	6	4,2	3,7
Fine screen	Mesh width	(mm)	0,25	0,25	0,25	0,25	0,25	0,25	0,25	0,25	0,25	0,25	0,25	0,25	0,25	
	Kvs-value ¹⁾	(m³/h)	6,2	10,1	16,8	24,3	32,9	49,5	80,3	115	189	303	405	590	1231	1883
	Zeta-value	--	2,1	2,5	2,2	2,8	3,8	4,1	4,4	4,9	4,4	4,5	4,9	7,3	4,1	3,6
Ratio of the free screen surface area to the area of the nominal diametSp.p.			10	8,4	8,3	7,1	6,8	5,2	4,4	3,7	2,8	2,7	2,4	2,3	2,7	2,9
Zeta-value ... range of tolerance for Kvs-values acc. to VDI/VDE 2173										¹⁾ Kvs-values based upon clean screen !						

on request possible in straight through form

Weights																
10.050	(kg)	2,5	3	4,5	5,5	7	9	13	19	26	38	54	110	--	--	
12.050	(kg)	3	4	5	7	9	12	16	21	30	43	61	121	154	335	
22.050	(kg)	3,5	4	5,5	7	9	12	16	21	28	41	58	115	154	335	
23.050	(kg)	3,5	4	5,5	7	9	12	16	21	32	47	64	--	--	--	
34./35.050	(kg)	4	5	6	8	10	13	19	24,5	35	51	71	144	--	--	

Information / restriction of technical rules need to be observed!

Operating and installation instructions can be downloaded at www.ari-armaturen.com.

ARI-Valves of EN-JL1040 are not allowed to be operated in systems acc. to TRD 110.

A production permission acc. to TRB 801 No. 45 is available (acc. to TRB 801 No. 45 EN-JL1040 is not allowed.)

The engineer, designing a system or a plant, is responsible for the selection of the correct valve.

Resistance and fitness must be verified (contact manufacturer for information, refer to Product overview and Resistance list).