



### MODEL :

- C221 CAST IRON/A126Gr-FC20-JIS-10K
- C222 CARBON STEEL WCB-JIS-10K
- C223 STAINLESS STEEL 304/SCS13-JIS-10K
- C224 STAINLESS STEEL 316/SCS14-JIS-10K

### FEATURES :

- FACE TO FACE DIMENSIONS: JIS B2002
- END FLANGE DIMENSIONS: JIS B2239
- DESIGN: ANSI 16.34
- TEST: JIS B2203
- WITH ISO 5211 MOUNTING PAD
- INVESTMENT CASTING BODY
- BLOW-OUT PROOF STEM / FULL BORE
- LEVER OPERATED OR GEAR OPERATED

### MATERIALS LIST :

ITEM	PART NAME	MATERIALS			
1	BODY	FC20	WCB	SCS13	SCS14
2	CAP	FC20	WCB	SCS13	SCS14
3	BALL	SCS13	SCS13	SCS13	SCS14
4	SEAT	TFM			
5	STEM	SUS304	SUS304	SUS304	SUS316
6	GASKET	TFM			
7	THRUST WASHER	TFM			
8	PACKING	TFM			
9	STEM PACKING	TFM			
10	GLAND	SUS13			
11	GLAND BOLT	SUS304			
12	HANDLE	WCB			
13	STOPPER	SUS304			
14	SNAP RING	SUS304			
15	BOLT	SUS304			
16	HANDLE BOLT	SUS304			
17	PLASTIC COVER	PLASTIC			

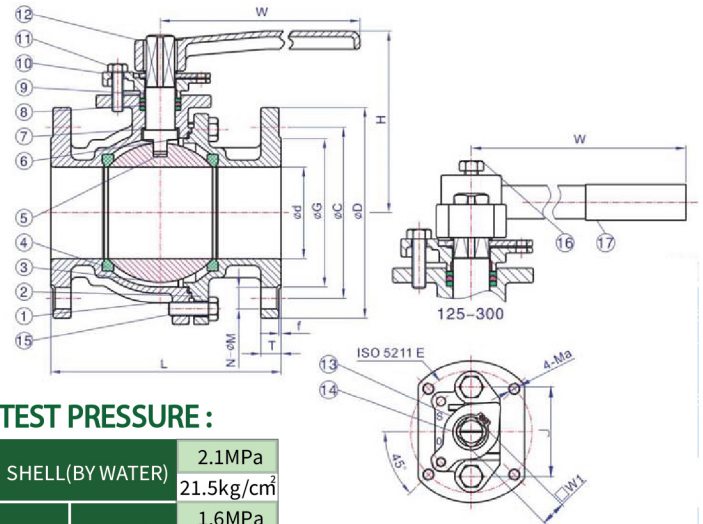

### TEST PRESSURE :

SHELL (BY WATER)	2.1MPa
	21.5kg/cm <sup>2</sup>
SEAT	1.6MPa
	16.5kg/cm <sup>2</sup>
	0.6MPa
	6kg/cm <sup>2</sup>

### DIMENSIONS :

SIZE	d	D	C	G	f	T		N-ØM	L	H	W	W1	J	ISO 5211	E	Ma
						FC	SUS									
1/2"	15	95	70	51	1	16	12	4-Ø15	110	70	160	12	50	F04	42	M5
3/4"	20	100	75	56	1	18	14	4-Ø15	120	73	160	12	50	F04	42	M5
1"	25	125	90	67	1	18	14	4-Ø19	130	77	160	12	50	04	42	M5
1-1/4"	32	135	100	76	2	20	16	4-Ø19	140	85	160	12	50	F05	50	M6
1-1/2"	40	140	105	81	2	20	16	4-Ø19	165	104	186	17	62	F07	70	M8
2"	50	155	120	96	2	20	16	4-Ø19	180	114	186	17	62	F07	70	M8
2-1/2"	65	175	140	116	2	22	18	4-Ø19	190	142	324	21	75	F07	70	M8
3"	80	185	150	126	2	22	18	8-Ø19	200	153	324	21	75	F10	102	M10
4"	98	210	175	151	2	24	18	8-Ø19	230	166	324	21	75	F10	102	M10
5"	125	250	210	182	2	24	20	8-Ø23	300	224	750	24	89	F12	125	M12
6"	150	280	240	212	2	26	22	8-Ø23	340	247	750	24	89	F12	125	M12
8"	198	330	290	262	2	26	22	12-Ø23	450	305	1000	32	100	F12	125	M12
10"	250	400	355	324	2	30	24	12-Ø25	530	327	1000	32	100	F14	140	M16
12"	300	445	400	368	3	32	24	16-Ø25	610	355	1000	32	100	F14	140	M16