

ELECTRO-PNEUMATIC POSITIONER *EPL & EPR Series*

EPL & EPR Series are the rugged control devices which stand up to harsh environments and engineered to meet the highest and most demanding control performance that the process industries of today require

FEATURES

- Easy maintenance
- Precise calibration with simple SPAN and ZERO adjustments
- Simple conversion to direct acting or reverse acting
- 1/2 split range available
- Rugged aluminum housing with corrosion-resistant coating
- Vibration resistant design
- Stainless steel gauges standard
- Restricted pilot valve orifice kit for small actuators included
- Certified for ATEX (Ex) Eex md B T5 (05 ATEX 1076X) by NEMKO in conformance with EN 50014:1997, EN 50018:2000 and EN 50028:1987
- Certified for EMC (K1046 / E04) in conformance with EN 61000-6-2:2001 and EN 61000-6-4:2001 by RWTUV
- Certified for Ex md B T6 (99-1075-Q1), Ex md C T6 (2000-1057-Q1), and Ex ia B T6 (2000-1056-Q1) by KOSHA



EPL (Linear Type)



OPTIONS AVAILABLE

- Position transmitter (4...20mA output signal)
- Two limit switches (open and close)



EPR (Rotary Type)



SPECIFICATIONS

| | EPL | | EPR | |
|------------------------|--|--------|----------------------------|--------|
| | Linear Type (lever feedback) | | Rotary Type (cam feedback) | |
| | Single | Double | Single | Double |
| Input Signal | 4...20mA @ 24V DC (Note.1) | | | |
| Input Resistance | 235 + 15 | | | |
| Supply Air Pressure | Max. 7.0bar (100psi) | | | |
| Standard Stroke | 10 ~ 80mm (Note.2) | | 60 ~ 100; (Note.2) | |
| Pneumatic Connections | Rc 1/4 or NPT 1/4 | | | |
| Electrical Connections | G 1/2 or NPT 1/2 | | | |
| Protection Class | Ex md B T6, Ex md C (H ₂)T6, IP66, Ex ia B T6 Eex md B T5 for ATEX (Ex) | | | |
| Ambient Temperature | -20 ~ 70 | | | |
| Pressure Gauge | Stainless Steel | | | |
| Output Characteristics | Linear | | | |
| Linearity | Within + 1.0% F.S. | | Within + 1.5% F.S. | |
| Sensitivity | Within 0.2% F.S. | | Within 0.5% F.S. | |
| Hysteresis | Within 0.5% F.S. | | Within 1.0% F.S. | |
| Repeatability | Within + 0.5% F.S. | | | |
| Air Consumption | 5 LPM (Sup. 1.4 kgf/cm ²) | | | |
| Flow Capacity | 80 LPM (Sup. 1.4 kgf/cm ²) | | | |
| Body Material | Aluminum Diecast | | | |
| Weight | 2.9kg (with a terminal box) | | | |

[Note]: 1) 1/2 split range can be adjusted
 2) Feedback lever is available for stroke 80~150mm (EPL)
 3) Stroke can be adjusted to 0°~60° or 0°~100° (EPR)

HOW TO ORDER

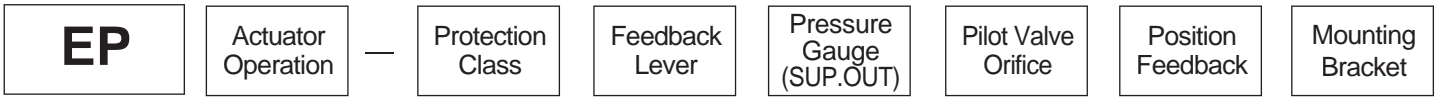

| Description | Code |
|---|---|
| Actuator Operation : | L : Linear Type R : Rotary Type |
| Protection Class : | F : Flameproof (Ex md IIB T6 / Ex md IIC T6) I : Intrinsic Safety (Exia IIB T6) W : Weatherproof to IP66 A : Flameproof (Ex md IIB T5) for ATEX |
| Feedback Lever : • Linear Type • Rotary Type | A : Stroke (10~80mm) B : Stroke (70~150mm) A : Fork Lever M6 × 40L B : Fork Lever other size on request N : Namur Shaft (direct mounting) |
| Pressure Gauge : | 1 : 6bar (90psi) 2 : 10bar (150psi) |

| Description | Code |
|---|--|
| Pilot Valve Orifice : | S : Standard (actuator volume over 180cm ³) M : Small Orifice (∅ 1.0 or ∅ 0.7) (actuator volume 90 ~ 180cm ³) |
| Position Feedback : (only for weatherproof) | N : None O : Position Transmitter (4 ~ 20mA Output Signal) L : Two SPDT Limit Switches (only for EPR) |
| Mounting Bracket : | N : None L : DIN / IEC534 (for EPL) R : DIN VDI / VDE3845 (for EPR) F : DHCT Bracket 80 × 30 |

DIMENSIONS

unit : mm

EPL - LINEAR TYPE

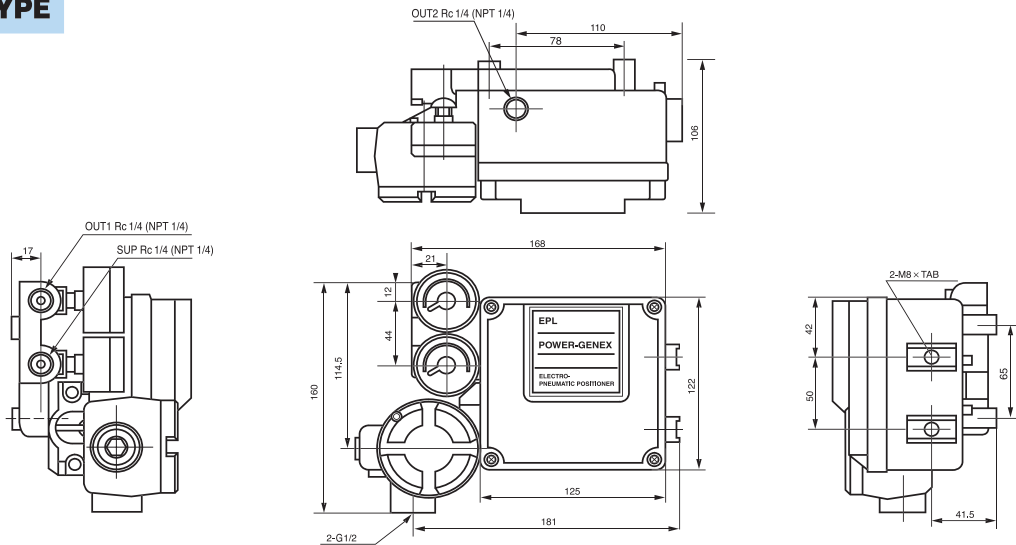

EPR - ROTARY TYPE

