



A multi-tier open charcoal grill equipped with accessories to perform a range of cooking techniques using grills, Teppanyaki hot plates or skewers. Robata grilling lends to an array of foods from meat, fish, seafood and vegetables, imparting light smoky aromas and flavours we seek in grill cooking. Manufactured with steels of the latest technology following the most rigorous quality controls.

The MIBRASA® Robatayaki RMSE has an incorporated elevating system, designed and patented by MIBRASA® enabling height adjustments between the grill and hot coals to provide the chef with total control allowing them to cook with more efficiency. Originating from the Japanese tea ceremony, which over time found its way to the north Japanese fishermen utilising this method to keep food hot while out at sea for long periods.

The evolution of the Robatayaki has brought it into the modern day kitchen, where chefs prepare food and display their showmanship in front of diners allowing them to take part in the entire cooking experience.

STANDARD FEATURES

- Exclusive system for mid-tier cooking
- 3-tier cooking
- Regulable air inlet system
- Ventilation circuit with longitudinal openings
- Ash collector drawers
- Manufactured from stainless steel
- Interior ceramic insulation
- Combustion area with refractory surface

ACCESSORIES INCLUDED

- Top grill (x1)
- Lower grill (x1)
- Support bars (x4)
- Charcoal poker (x1)

OPTIONAL ACCESSORIES

- Extra top grill
- Extra lower grill
- Teppanyaki griddle
- Support bars (x2)
- Robatayaki stand
- Robatayaki stand castors

TECHNICAL INFORMATION	60	80	115
Fire up time (min)	20	20	20
Cooking temperature (°C)	250	250	250
Charcoal consumption for service (kg)	3	4	5
Performance (h)	5	5	5
Cooking surface area (mm)	425 x 250	603 x 250	950 x 250
Equivalent Power (kW)	1.5	1.8	2
Exhaust rate (m3/h)	1200	1500	2000

SPECIFICATIONS ARE SUBJECT TO CHANGE WITHOUT NOTICE.

Model	A	B	C	D	E	F	G	H	I	J	K
RMSE60	740	480	620	425	250	385	150	550	325	445	1025
RMSE80	920	660	800	603	250	385	150	550	325	445	1025
RMSE115	1265	1005	1140	950	250	385	150	550	325	445	1025

RMSE60, RMSE80, RMSE115

ROBATAYAKI



* Photo above features the Robatayaki RMSE115.

From top to bottom:

- 2 top grills
- skewers
- 2 lower grills and teppanyaki griddle

Not all above accessories are included with purchase. Please refer to "ACCESSORIES INCLUDED".

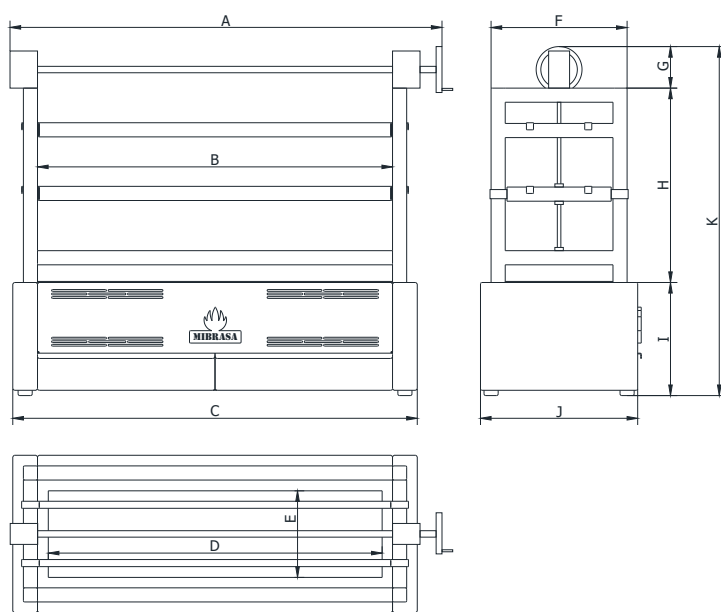

National Head Office
156 Swann Drive
Derrimut VIC 3026
Tel: +61 3 8369 4600
Fax: +61 3 8369 4699

www.comcater.com.au

Melbourne
96-100 Tope Street
South Melbourne VIC 3205
Tel: +61 3 8699 1200
Fax: +61 3 8699 1299

Sydney
20/4 Avenue of the Americas
Newington, NSW 2127
Tel: +61 2 8775 9500
Fax: +61 2 9648 4762

Brisbane
1/62 Borthwick Avenue
Murarrie QLD 4172
Tel: +61 7 3900 2700
Fax: +61 7 3399 5311

Perth
Unit 16, 7 Abrams Street
Balcatta, WA 6021
Tel: +61 8 6217 0700
Fax: +61 8 6217 0799