

CMW-I CMW-IMOD

HOOD WITH COLD MIST TECHNOLOGY

With Capture Jets

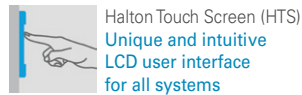
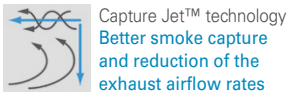

Recommended combinations

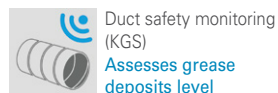
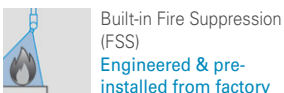

Two of these combinations in brief:

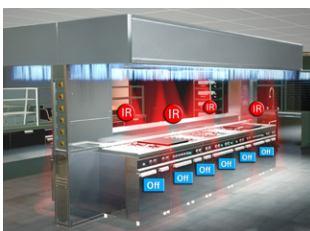

M.A.R.V.E.L. (MRV)

This technology has the unique ability to adjust the exhaust airflow hood by hood and in a fully independent way. Benefit from massive savings!

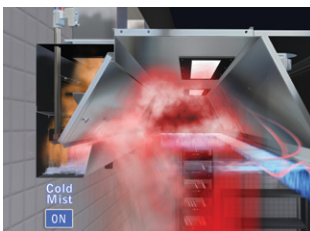

Cold Mist on Demand

Up to 80% savings on the water consumption: the cold mist activates only when the cooking appliances covered by the hood require it.

APPLICATIONS

CMW-I hoods are specially designed for heavy duty cooking appliances or solid fueled broilers such as charcoal ovens, barbecues, gas woks or charbroilers, whether installed in a closed or open cooking area. Such cooking appliances represent a major fire safety concern.

CMW-I hoods are equipped with the Cold Mist technology that is based on the use of a Cold Water Mist curtain all along the exhaust plenum. It acts first as a spark arrester and cools the incoming exhaust air. Its combination with the integrated baffle filters provides high efficiency filtration on the particles emitted by cooking appliances. As an option, the water mist can be activated on demand (CMW-IMOD), depending on the cooking appliances activity. This technology generates up to 80% savings on water consumption.

CMW-I hoods are also equipped with the Capture Jet™ technology.

- HACCP⁽¹⁾ certified (CMW-IMOD).
- Energy savings: reduction of the exhaust airflow rates due to Capture Jet™ technology.
- Maximum fire safety: The Cold Mist acts at the same time as an air cooler and a spark/flame arrester, preventing them from entering the exhaust plenums
- Enhanced hygiene: the combination of the Cold Mist and the intercepting baffles in the exhaust plenum prevents the build-up of grease deposits in the ductwork. The automatic wash cycle thoroughly cleans the inside of the exhaust plenum at the end of the cooking period.
- Up to 80% savings on water consumption with the optional cold Mist On Demand technology (CMW-IMOD): the water mist is automatically activated only when it is strictly required, depending on the real needs of the cooking appliances.
- Performance tested independently in accordance with the ASTM 1704 standard.

DESCRIPTION AND DIMENSIONS

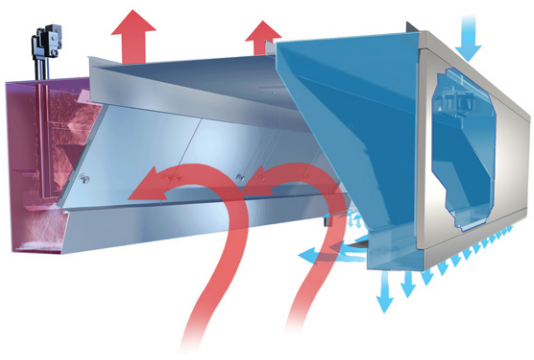
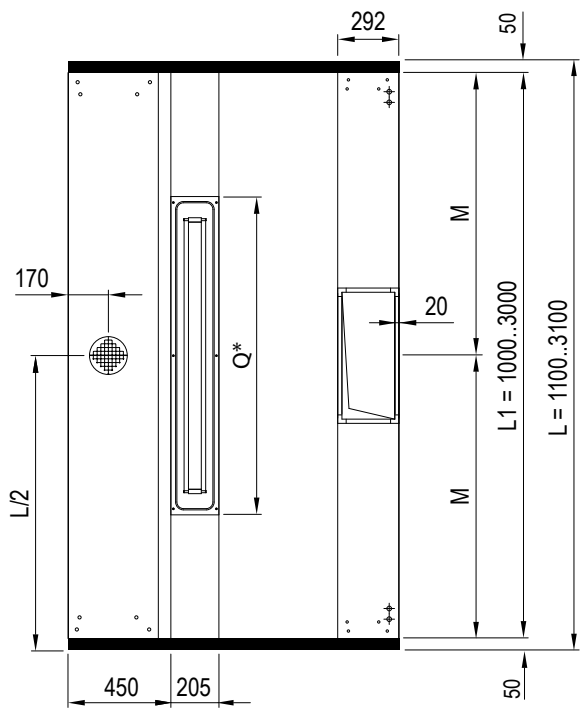
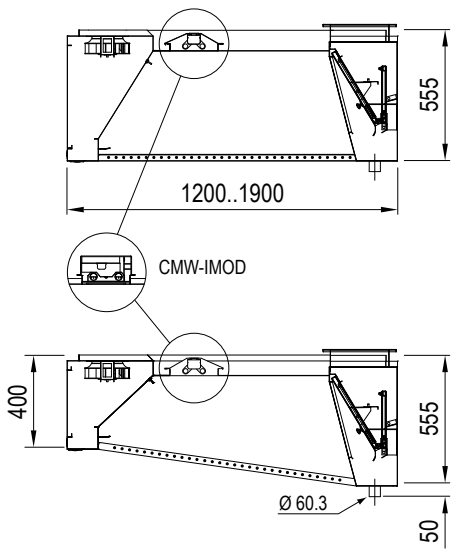

Notes
 The dimensions shown are for modular sections only. Longer hoods are assembled using a combination of separate modules to make delivery and on-site handling easier. Other Capture Jet™ air supply possibilities or connections are available on request.

LOCATION OF CONNECTIONS (mm)

Number of exhaust and supply connections to be assessed in relation to the length of the modules, the calculation of airflow rates depending on the configuration of the cooking appliances and the Cold Mist requirements.

L	Exhaust	Light
	M	Q*
1600	L1/2 250x450	1020
2100	L1/2 250x600	1320
2600	L1/2 250x750	1320
3100	L1/2 250x850	1320

* 1020 (L1 ≤ 1500, 2x27W), 1320 (L1 > 1500, 2x36W)



CCW-MOD control cabinet for CMW-IMOD and CMW-FMOD hoods

The CCW-MOD cabinet automatically controls the « Cold Mist » for each section of hood, as well as the cleaning cycles at the end of the cooking period. It is fitted with the Halton Touch Screen, which is an intuitive and efficient interface. Cleaning cycles are entirely and easily adaptable to the kitchen's activity. They can also be triggered manually.

The Halton Touch Screen can also manage all other solutions in the Halton High Performance Kitchen Solutions. It is fully communicative, notably with the Building Management System.