

QB Series

Unidirectional seal Knife Gate Valve

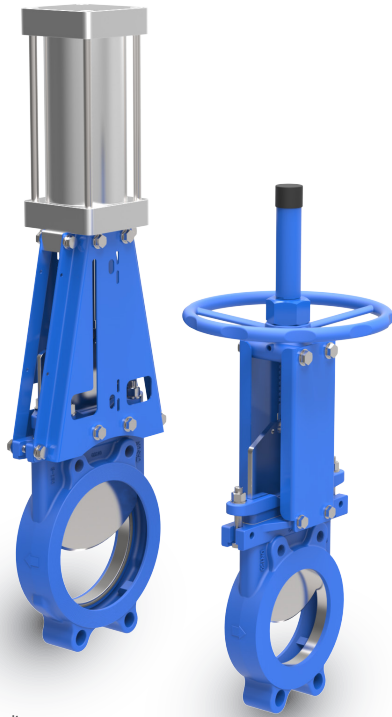

Features:

- # Unidirectional sealing
- # 1PC Body design
- # Full port design
- # Mixed with a variety of materials packing

- Model:** QBZ73X
- Working Pressure:** DN50-DN100 16bar
 DN125-DN200 14bar
 DN250-DN300 12Bar
 DN350-DN400 10bar
 DN450-DN550 8bar
 DN600-DN650 5bar
 DN700-DN750 4bar
 DN800-DN900 3bar
 DN1000-DN1400 2bar
- Design Standard:** MSS SP-81
- Flange Standard:** DIN PN10,PN16,150LB ,JIS 10K,TABLE E/D
- Face to Face:** MSS SP-81
- Testing Standard:** API-598
- Transmission:** manual, electric, pneumatic, hydraulic, sprocket, electro-hydraulic, gear
- Main material:** WCB,CF3M,CF8M,CF8
- Wedge material:** SS316L,SS304
- Sealing material:** NBR,EPDM,FKM,Metal
- Packing:** Aramid fiber,high-water-based rubber packing graphite wheel
- Applicable medium:** for pulp, cement slurry, gold ore powder,coal slurry, pulp, chemical treatment of sewage, sedimentation tanks, asphalt,acid and other liquids and other media.

Product Description:

QB Series Knife gate valve is with replaceable rubber seal knife gate structure, its sealing principle is mainly by closely connection between gate and rubber seals. Its main characters is that the rubber sealing ring is set in seat'groove and is locked by metal seat, which will prevent rubber seal off when opening and closing the valve. If the seal is broken, you can remove the metal seat and replace the rubber seal, which will greatly improve valve' working efficiency. This valve is a cost-effective, high-performance products. The series of knife gate valve can be equipped with pneumatic actuators, in order to meet the requirements of different industrial and mining use.

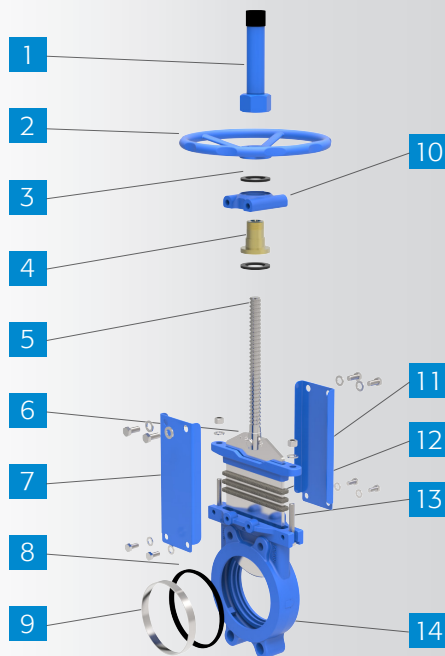

Code	Name	Material	QTY
1	Handle Cover	Q235+Painting	1
2*	Hand Wheel	GGG40	1
3	Bearing	ZChSnSb10-6	2
4	Stem Nut	Brass	1
5	Stem	2Cr13/SS304/SS316	1
6	Disc	SS304/SS316/F55/2205	1
7	Yoke	Q235	1
8	Seat	EPDM/NBR/PTFE/Metal	1
9	Seat Cover	SS304/SS316	1
10	Yoke Head	GGG40	1
11	Packing Gland	WCB/CF8	1
12	Packing	Aramid PTFE	3-5
13	Bolt	Fe+Zn With Painting/SS304	N
14	Body	WCB/GGG40/CF8/CF8M	1

*electric, pneumatic, hydraulic, sprocket, electro-hydraulic, gear **available**

Dimension

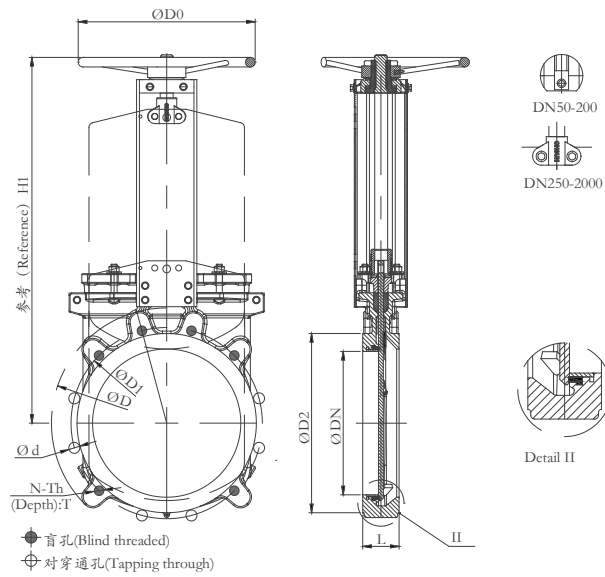

unit:mm

DIN2632 PN10									ANSI 150LB								
DN	L	D	D1	D2	D0	N-Th	d	H1	DN	L	D	D1	D2	D0	N-Th	d	H1
50	48	165	125	99	180	4-M16	$\text{Ø}18$	260	2"	48	152	121	92	180	4-5/8"	$\text{Ø}19$	260
65	48	185	145	118	200	4-M16	$\text{Ø}18$	292	2-1/2"	48	178	140	105	200	4-5/8"	$\text{Ø}19$	292
80	51	200	160	132	200	8-M16	$\text{Ø}18$	320	3"	51	191	153	127	200	4-5/8"	$\text{Ø}19$	320
100	51	220	180	156	240	8-M16	$\text{Ø}18$	358	4"	51	229	191	157	240	8-5/8"	$\text{Ø}19$	358
125	57	250	210	184	260	8-M16	$\text{Ø}18$	395	5"	57	254	216	186	260	8-3/4"	$\text{Ø}22$	395
150	57	285	240	211	280	8-M20	$\text{Ø}23$	450	6"	57	279	242	216	280	8-3/4"	$\text{Ø}22$	450
175	57	305	265	237	280	12-M20	$\text{Ø}23$	504	8"	70	343	299	270	300	8-3/4"	$\text{Ø}22$	532
200	70	340	295	266	300	8-M20	$\text{Ø}23$	532	10"	70	406	362	324	320	12-7/8"	$\text{Ø}25$	670
250	70	395	350	319	320	12-M20	$\text{Ø}23$	670	12"	76	483	432	381	350	12-7/8"	$\text{Ø}25$	758
300	76	445	400	370	350	12-M20	$\text{Ø}23$	758	14"	76	533	476	413	400	12-1"	$\text{Ø}29$	857
350	76	505	460	429	400	16-M20	$\text{Ø}23$	857	16"	89	597	540	470	450	16-1"	$\text{Ø}29$	946
400	89	565	515	480	450	16-M24	$\text{Ø}27$	946									

PN10 Threaded hole and Tapping hole

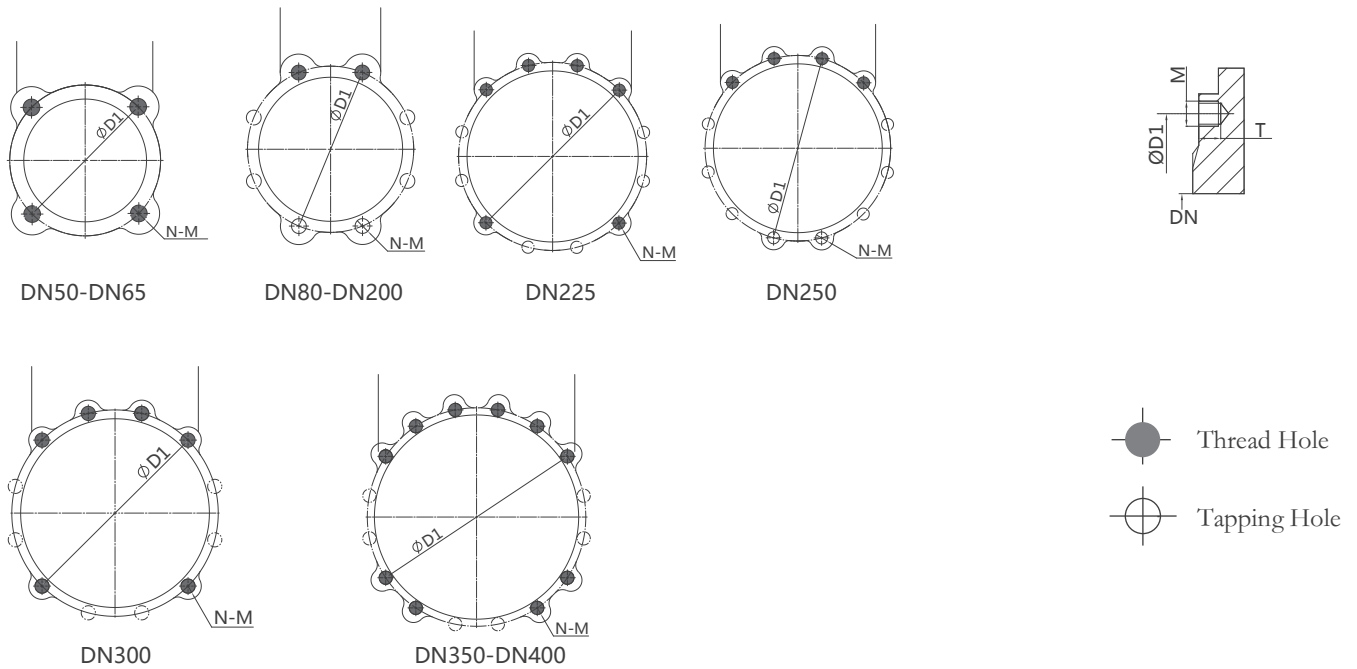

DN	D1	N	PN10			Thread Hole	Tapping Hole
			M	T			
50	125	4	M16	13	2	2	
65	145	4	M16	13	2	2	
80	160	8	M16	13	2	6	
100	180	8	M16	13	2	6	
125	210	8	M16	16	2	6	
150	240	8	M16	16	2	6	
200	295	8	M20	20	2	6	
225	310	12	M20	20	6	6	
250	350	12	M20	20	4	8	
300	400	12	M20	20	6	6	
350	460	16	M20	20	10	6	
400	515	16	M24	24	10	6	

150LB Threaded hole and Tapping hole

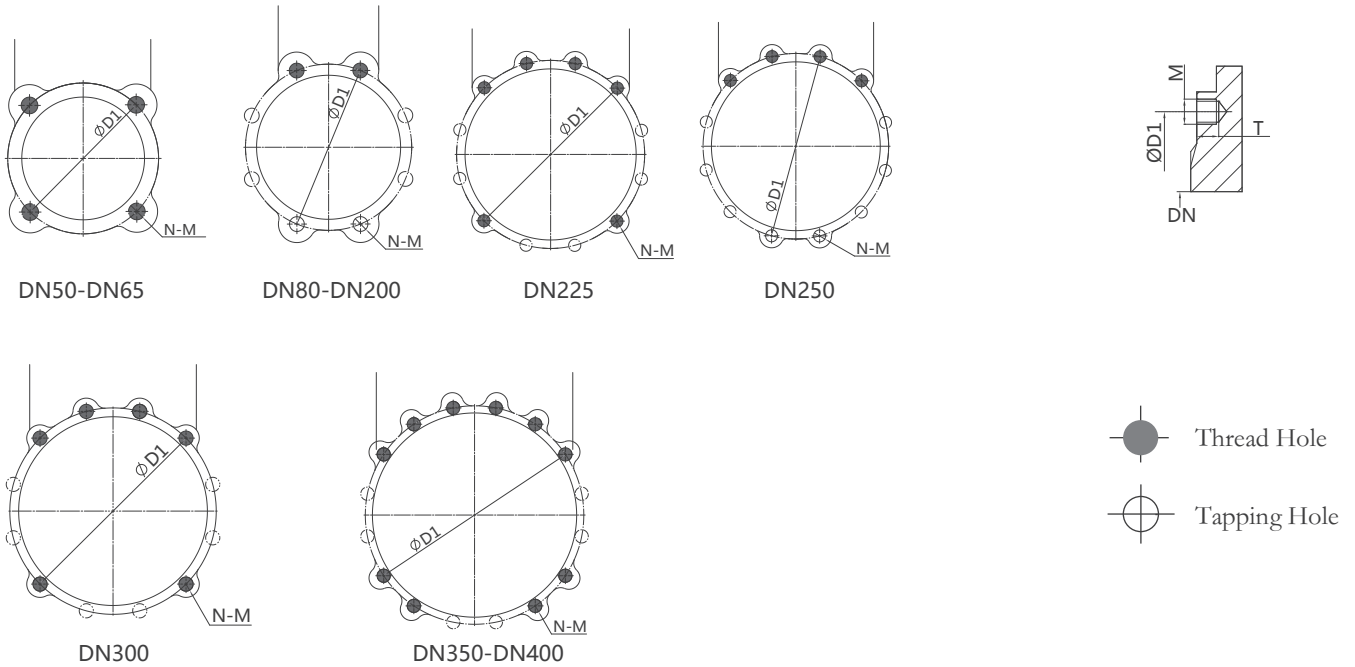

DN	D1	N	ANSI 150LB		Thread Hole	Tapping Hole
			M	T		
2"(DN50)	121	4	4-5/8"	13	2	2
2-1/2"(DN65)	140	4	4-5/8"	13	2	2
3"(DN80)	153	4	4-5/8"	13	2	2
4"(DN100)	191	8	8-5/8"	13	2	6
5"(DN125)	216	8	8-3/4"	16	2	6
6"(DN150)	242	8	8-3/4"	16	2	6
8"(DN200)	299	8	8-3/4"	20	2	6
10"(DN250)	362	12	12-7/8"	20	2	6
12"(DN300)	432	12	12-7/8"	20	6	6
14"(DN350)	476	12	12-1"	20	6	6
16"(DN400)	540	16	16-1"	24	10	6