

序号No.	配件名称 Spare Parts	材料 Material	6	支架板 Yoke	Q235(Cr. D)	12	气缸 Pneumatic	组合件 Assembly
1	阀体 Body	GGG40	7	销轴 Pin	45#钢 Steel	13	电磁阀 Solenoid valve	组合件 Assembly
2	闸板 Disc	SS304	8	夹头 Chuck	WCB	14	过滤器 Filter	组合件 Assembly
3	导向垫 Guide Pad	PTFE	9	活塞杆 Piston Rod	45#+Cr	15	楔块 Wedge	GGG40
4	填料 Packing	PTFE	10	行程开关 Switch	组合件 Assembly		标准件 Bolts/Nuts	铁镀锌 Fe+Zn
5	压条 Packing Gland	WCB	11	支架头 Yoke Head	GGG40			

备注(Note): 1、设计按(Design): JB/T8691-2013
 2、法兰按(Flange): GB/T9113.1-2010
 3、结构长度按(Face to face): GB/T15188.2-94 chart6-7
 4、试验和验收(Testing): GB/T13927-2008

刀闸阀主要外形及连接尺寸
 Outline and Dimension

型号 Model: QBZ673W-10G

DN(mm)	尺寸 size											
	L	D	D1	D2	D0	N-Th	T	盲孔	对穿孔	d	H1	G
50	48	165	125	99	100	4-M16	12	4	0	018	417	1/2"
65	48	185	145	118	100	4-M16	12	4	0	018	460	1/2"
80	51	200	160	132	100	8-M16	12	4	4	018	510	1/2"
90	51	210	170	142	100	8-M16	12	4	4	018	569	1/2"
100	51	220	180	156	100	8-M16	12	4	4	018	600	1/2"
125	57	250	210	184	100	8-M16	12	4	4	018	628	1/2"
150	57	285	240	211	125	8-M20	14	4	4	023	780	1/2"
175	57	305	265	237	125	12-M20	14	6	6	023	852	1/2"
200	70	340	295	266	125	8-M20	16	4	4	023	880	1/2"
225	70	350	310	282	125	12-M20	16	6	6	023	1010	1/2"
250	70	395	350	319	160	12-M20	16	6	6	023	1088	1/2"
300	76	445	400	370	160	12-M20	16	6	6	023	1232	1/2"
350	76	505	460	429	200	16-M20	18	10	6	023	1390	1/2"
400	89	565	515	480	200	16-M24	20	10	6	027	1528	1/2"
450	89	615	565	530	200	20-M24	20	14	6	027	1659	1/2"
500	114	670	620	582	250	20-M24	24	14	6	027	1846	3/4"
550	114	725	680	638	250	20-M27	27	14	6	030	2061	3/4"
600	114	780	725	682	250	20-M27	27	14	6	030	2158	3/4"
650	114	845	780	732	250	24-M27	27	16	8	030	0	3/4"
700	127	895	840	794	320	24-M27	27	16	8	030	0	1"
750	127	970	900	855	320	24-M30	30	16	8	033	0	1"
800	127	1015	950	901	320	24-M30	30	16	8	033	0	1"
850	127	1070	1000	955	320	28-M30	30	20	8	033	0	1"
900	127	1115	1050	1001	320	28-M30	30	20	8	033	0	1"
1000	149	1230	1160	1112	320	28-M33	35	20	8	036	0	1"
1100	149	1340	1260	1220	0	28-M33				036	0	
1200	156	1455	1380	1328	0	32-M36				039	0	
1350	171	1630	1540	1480	0	36-M39				042	0	
1400	171	1675	1590	1530	0	36-M39				042	0	
1500	198	1795	1705	1640	0	40-M39				042	0	
1600	198	1915	1820	1750	0	40-M45				048	0	
1800	219	2115	2020	1950	0	44-M45				048	0	
2000	250	2325	2230	2150	0	48-M45				048	0	

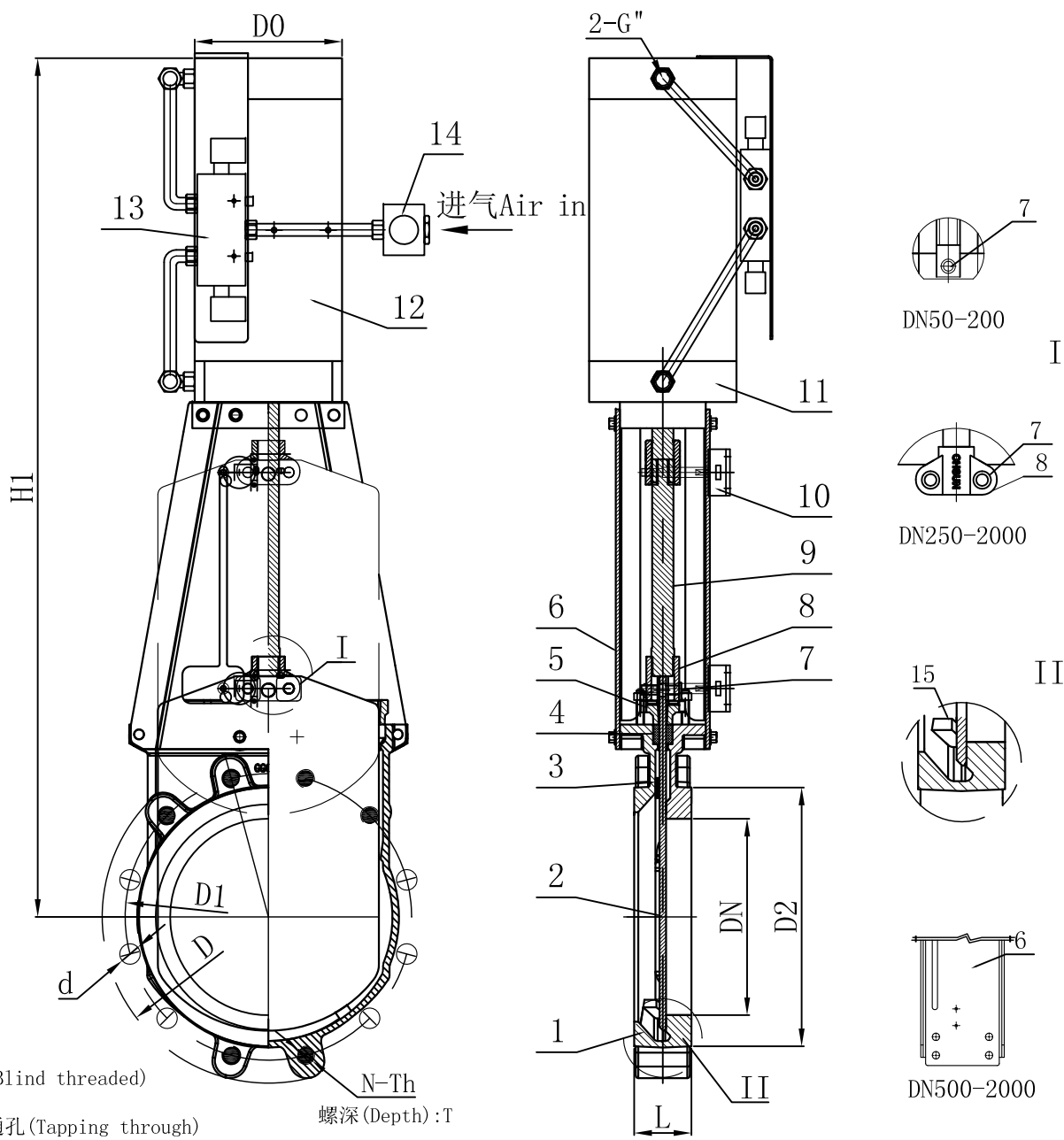

刀闸阀 Knife Gate Valve
 QBZ673W-10G