

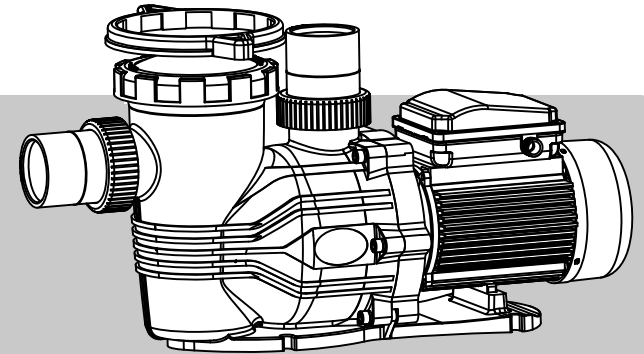

# WL-BDP SERIES

## INSTALLATION & OPERATION MANUAL OF PUMP



WL-BDP200  
WL-BDP300  
WL-BDP400



GUANGDONG LASWIM WATER ENVIRONMENT EQUIPMENT CO., Ltd



To scan QR code for more information.  
For more information please visit [www.laswimwater.com](http://www.laswimwater.com)

202102

Please Read The Manual Carefully Before Use.

## ⚠ IMPORTANT SAFETY INSTRUCTIONS

1. Install a water hammer suppressor or check valve on the outlet pipe of the pump to reduce the damage of the water hammer to the pump and prevent the reverse flow of water from causing the impeller to reverse and fall off.
2. Before the pump working please check the inlet and return water system of the pump and the corresponding valve is close or not .The pump cannot run for more than 10mins in the closed piping system without any water output.
3. If the pump needs to fill the water in the self-priming water source, the pump should be as close as possible to the water source, so that the self-priming distance and suction range are shortened and reduced to avoid damage to the pump.
4. The Pump Should Not Be Operated Without Water In The Pump Body. Dry And Water Shortage Running Can Result In Pump Damages.
5. The Pump should be carried out in accordance with the single-Phase or three-phase wiring diagrams conforming to local standards, furnished with electrical leakage protector and overheating protections. And the single-phase pump less than 1.5kw does not need to be equipped and installed separately with overheating protection. When the three-phase motor is in the absence of load, that is, the pump body has no water, the technician should check whether the motor steering is consistent with the direction of the sign, such as consistent with the direction of the sign, indicating that it works normally and can be powered on. The reverse operation can not be too long, about 4-5 seconds, otherwise it will cause damage to the pump, should be the three-phase electricity any set of lines to replace, the motor can work normally.

## 1 PRODUCT INTRODUCTION

BDP series high performance plastic centrifugal pump delivers high flow rates. It uses safe and reliable polypropylene thermoplastic material as the main material of the water pump, which has the characteristics of high temperature and high pressure resistance. The shaft seal of the product uses ceramic carbon material, which has the characteristics of wear resistance, safety and stability, good sealing, etc., which can ensure that the pump can run stably for a long time.

## PRODUCT FEATURES

1. High efficiency motors IE3.
2. IPX5 waterproof standard.
3. Asynchronous, two poles.
4. Built-in thermal protection and overload protection.
5. The advanced diffuser and high efficiency turbine maximize water flow and energy efficiency while minimizing turbulence and noise.

.1.

## 2 PRODUCT STRUCTURE

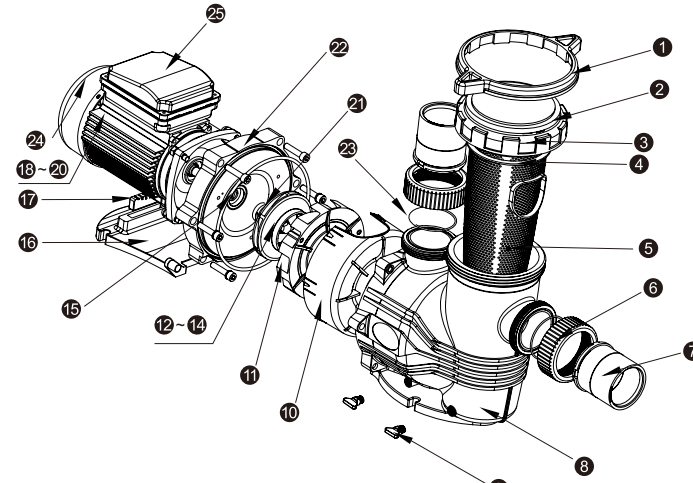

- |                           |                                  |                   |
|---------------------------|----------------------------------|-------------------|
| ① Tool                    | ⑨ Drain plug                     | ⑰ Motor pad       |
| ② Transp cover            | ⑩ Protective sleeve for diffuser | ⑱ 2.0HP motor     |
| ③ Transp ring lock        | ⑪ Diffuser                       | ⑲ 3.0HP motor     |
| ④ Transp O-ring           | ⑫ 2.0HP impeller                 | ⑳ 4.0HP motor     |
| ⑤ Basket                  | ⑬ 3.0HP impeller                 | ㉑ Mechanical seal |
| ⑥ Union nut               | ⑭ 4.0HP impeller                 | ㉒ Seal plate      |
| ⑦ Union bulkhead & O-ring | ⑮ O-ring                         | ㉓ O-ring          |
| ⑧ Pump body               | ⑯ Base                           | ㉔ Fan and cover   |
|                           |                                  | ㉕ Capacitor box   |

## 3 DIMENSIONS AND TECHNICAL PARAMETERS TABLE

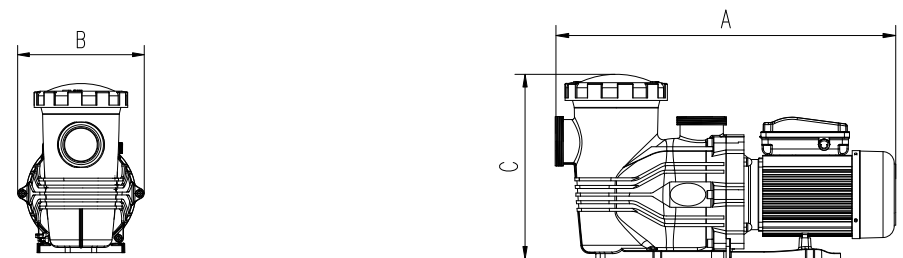

Model	Horse power (HP)	Phase	Rated Power (KW)	Voltage (V)	Current (AMP)	connection size (Inch/mm)	A (mm)	B (mm)	C (mm)
WL-BDP200M	2	1	1.5	220	8.6	2 "/63	685	280	370
WL-BDP300M	3	1	2.2	220	10.6	2.5 "/75	695	280	370
WL-BDP200T	2	3	1.5	380	3.2	2 "/63	685	280	370
WL-BDP300T	3	3	2.2	380	3.8	2.5 "/75	695	280	370
WL-BDP400T	4	3	2.7	380	4.4	2.5 "/75	710	280	370

.2.

## 4 PRODUCT PERFORMANCE CURVE

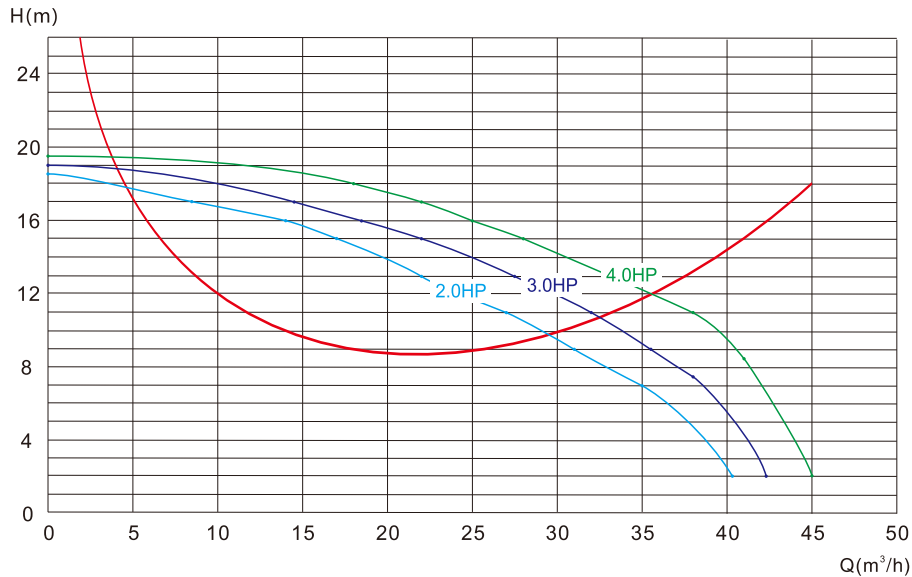

## 5 PRODUCT INSTALLATION AND OPERATION

### PUMP INSTALLATION

1. Only qualified, licensed personnel should install pump and wiring.
2. Be located away from corrosive or flammable chemicals.
3. Be solid - Level - Rigid - Vibration free. (To reduce vibration and pipe stress, bolt pump to mount.)
4. Allow pump suction inlet height to be as close to water level as possible.
5. Allow use of short, direct suction pipe (To reduce friction losses).
6. Allow for valves in suction and discharge piping.
7. Have adequate floor drainage to prevent flooding.
8. Be protected from excess moisture.
9. Allow adequate access for servicing pump and piping

### ⚠ NOTICE

All pump power supply must be installed in line with the national standard leakage switch and leakage protection device, and must be connected to a qualified ground wire, and the ground wire can not be connected to the water pipe.

### PUMP OPERATION

1. RELEASE ALL PRESSURE from pump and piping system.
2. Open the valve of the pump inlet and outlet pipes until the pump's pre-filter shell is filled with water. If the pump is installed above the level, open the transparent cover and fill the pre-filter housing with water.
3. Clean and check the O-ring, after the lid is covered, rotate the upper tight cover clockwise.
4. Start the pump while ensuring that the components are well connected and safe. After the lid is covered, rotate the cover clockwise.
5. After the pump is started, please observe for a few minutes before leaving the pump.

### ⚠ NOTICE

1. Please close the inlet and outlet valves when opening the trap cover. Loosen the drain plug to discharge the air pressure or water pressure in the pump before opening. Please do not loosen the drain plug and trap ring lock and other fittings of the pump when the pump is working.
2. The trap ring lock can only be tightened using a special tool or wrench.
3. Please do not run pump dry. Running pump dry may damage seals, causing leakage and flooding. Fill pump with water before starting motor.
4. If the pump is shut down in a low temperature area, please open the drain plug to empty the water in the pump to prevent the water from freezing and destroying the pump.
5. If the pump is deactivated for a long time, disconnect the pump power supply and close the pump inlet and outlet pipe valves.
6. Before the pump is initially started and deactivated for a long time, the pump should be panned for several turns, and then the pump should be opened after checking that there is no abnormality.

## 6 THE MATERIAL OF MAIN PARTS

The pump body is made of safe and reliable polypropylene thermoplastics, which has the characteristics of high temperature and high pressure resistance, corrosion resistance and aging resistance, and no pollution, and the use of high-efficiency motors provides high performance power guarantee for the pump.

Pump housing: PP+35% GF

Impeller: PPO+30% GF

Filter basket: PP

Diffuser: PPO+30% GF

Shaft: 316L

Pump base: PP+30% GF

Mechanical Seal: stationary face-SIC,

rotating face-graphite, seal bellows - NBR,

Spring-316L

## 7 TROUBLE SHOOTING

### MOTOR CANNOT START

1. Disconnect switch or circuit breaker in off position.
2. Fuses blown or thermal overload open
3. Locked motor shaft
4. Motor windings burned out
5. Over-current protection or overheating protection
6. Disconnected or defective wiring
7. Insufficient voltage

### PUMP DELIVERS NO WATER

- 1 Pump is not primed
- 2 Closed valve in suction or discharge line
- 3 Leakage or air into suction system
- 4 Impeller clogged

### LEAKAGE

1. Check the screw, pipe fittings or cover is tighten.
2. Check the O-ring is clean or in good condition.

### NOISY PUMP AND MOTOR

1. Motor bearings are damaged.
2. Suction and discharge line partly plugged.
3. Vacuum hose plugged or too small.
4. Pump is not work properly.
5. Wear of the impeller.

### PUMP DOES NOT REACH FULL SPEED

1. Insufficient voltage
2. The power supply does not match the pump voltage

### MOTOR OVERHEATS

1. Insufficient voltage
2. The power supply does not match the pump voltage
3. The operating frequency does not match the rated frequency of the motor
4. Poor ventilation

### LOW PUMP CAPACITY

1. Valves in suction or discharge line partly closed.
2. Suction or discharge line partly plugged.
3. Suction or discharge line too small.
4. Filter basket excess debris.
5. The impeller has been logged.

### AIR BUBBLES AT INLET FITTINGS

1. Air enters the water pipe through the joint or valve.
2. Suction or discharge line plugged or the air is leakage.
3. Low water level in the pool.

.5.

## 8 ROUTINE MAINTENANCE

### CLEAN THE BASKET

1. Stop pump, close valves in suction and discharge, and release all pressure from system before proceeding.
2. Remove trap cover handle ring (turn counterclockwise). If necessary, tap handles gently with a rubber mallet.
3. Remove strainer basket and clean. Be sure all holes in basket are clear, flush basket with water and replace in trap with large opening at pipe connection port (between ribs provided). If basket is replaced backwards cover will not fit on trap body.
4. Clean and inspect lid O-Ring; reinstall on trap.
5. Clean O-Ring groove on trap body and replace cover and handle ring. To help keep cover from sticking, tighten hand tight only.
6. Prime pump.

### NOTICE

Failure or damage to this product, whether within the free warranty period or not, is not covered by the free warranty.

1. Failure or damage caused by not complying with the instruction manual, working environment other specified in the product, incorrect installation and operation.
2. Improper human use leads to damage to mechanical seals, bearings, impellers and other accessories.
3. Due to force majeure such as natural disasters (such as earthquakes, fires, etc.) or man-made reasons, the pump motor is directly damaged by water ingress.
4. The product is caused by other quality problems that are not the product itself, such as product damage caused by the user's poor transportation.

## 9 STORAGE AND TRANSPORTATION

### CLEAN THE BASKET

The pump should be carefully and gently placed during transportation to ensure the integrity of the packaging box. The pump should be stored in a ventilated and low humidity place.

.6.