

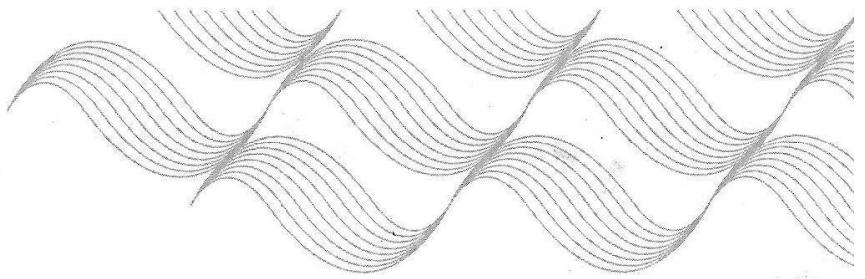

**LASWIM**



## INVERTER MINI POOL HEAT PUMP INSTALLATION AND OPERATION INSTRUCTIONS

LS03-IMN1-S4C6  
LS04-IMN1-S4C6  
LS05-IMN1-S4C6

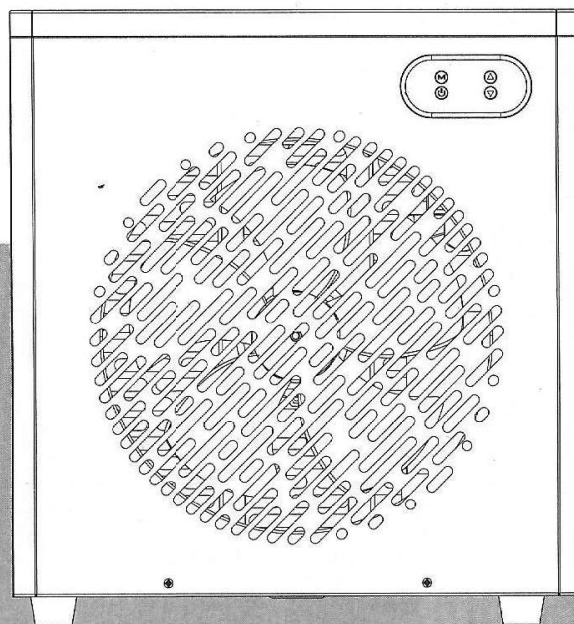

# Table of contents

<b>1. FOREWORD</b>	<b>02</b>
<b>2. SAFETY PRECAUTIONS</b>	<b>02</b>
2.1. Attention	02
2.2. Safety	03
<b>3. ABOUT YOUR HEAT PUMP</b>	<b>04</b>
3.1. Transportation	04
3.2. Accessories	04
3.3. Features	05
3.4. Operating condition and range	05
3.5. Technical parameter	06
3.6. Dimension	07
<b>4. INSTALLATION GUIDANCE</b>	<b>07</b>
4.1. Heat pump location and installation reminder	07
4.2. Wiring and power supply	09
4.3. Reference for protecting devices and cable specification	09
<b>5. OPERATION GUIDANCE</b>	<b>10</b>
5.1. Key function	10
5.2. Temperature display	10
5.3. Operation instruction	10
<b>6. TESTING</b>	<b>11</b>
6.1. Inspect the heat pump before use	11
6.2. Leakage detection notice and method	11
6.3. Trial	12
<b>7. MAINTENANCE</b>	<b>12</b>
<b>8. TROUBLE SHOOTING FOR COMMON FAULTS</b>	<b>12</b>
<b>9. SERVICE OPERATIONS</b>	<b>15</b>

# 1 FOREWORD

Thank you for choosing our inverter mini pool heat pump, which is designed for various small above ground pools. It is an ideal way for green pool heating.

We hope you'll enjoy using our heat pumps.

Thank you!



# 2 SAFETY PRECAUTIONS

We have provided important safety messages in this manual and on your heat pump. Please always read and obey all safety messages.

**Environment friendly R32 Refrigerant is used for this heat pump.**

## **WARNING: R32 Refrigerant**



The WARNING sign denotes a hazard. It calls attention to a procedure, practice, or the like, which, if not correctly performed or adhered to, could result in personal injury or injury to a third party. These signs are rare, but are extremely important.

	<p>a. Warning: risk of fire. Appliances using flammable refrigerants, keep the appliance away from fire source.</p>
	<p>b. It must be placed in well-ventilated area, indoor or closed area is not allowed.</p>
	<p>c. Repair and disposal must be carried out by trained service personnel</p>
	<p>d. Vacuumize completely before welding. Welding can only be carried out by professional personnel in service center.</p>

## 2.1 ATTENTION

---

- a. This appliance can be used by children aged from 8 years and above and, persons with reduced physical, sensory or mental capabilities or lack of experience and knowledge if they have been given supervision or instruction concerning use of the appliance in a safe way and understand the hazards involved.
- b. Children should be supervised to ensure that they do not play with the appliance.
- c. If the supply cord is damaged, it must be replaced by the manufacturer, its service agent or similarly qualified persons in order to avoid a hazard.
- d. Do not use any methods to accelerate the defrosting process or to clean, other than those recommended by the manufacturer.
- e. The appliance shall not be stored in a room continuously operating ignition sources (for example: open flames, an operating gas appliance or an operating electric heater.)
- f. Do not pierce or burn.
- g. The installation, the electric connection and the start up must be carried out by specialized and professional person.
- h. The mains supply cord and plug must be kept away from any water source and well protected from damaged.
- i. The appliance shall be installed in accordance with national wiring regulations.
- j. In a concern to a constant improvement, our products can be modified without notice; the present pictures in this note or the characteristics which are described are not contractual.
- k. Leakage test must be performed after installation. Be aware that refrigerants may not contain an odour.
- l. Please don't stack substances, which will block air flow near inlet or outlet area, otherwise the efficiency of the heat pump will be reduced or even stopped.
- m. Set proper temperature in order to get comfortable water temperature to avoid overheating or overcooling. It is essential to maintain the temperature in the swimming pool lower than the recommended value by the swimming pool's manufacturer.
- n. In order to optimize the heating effect, please install heat preservation insulation on pipes between swimming pool and the heat pump, and please use a recommended cover on the swimming pool. It is essential to maintain the temperature in the swimming pool lower than the recommended value by the swimming pool's manufacturer.
- o. Connecting pipes of the swimming pool and the heat pump should be  $\leq 10\text{m}$ .
- p. If a repair is required, please contact the nearest after-sales service center. The repair process must be strictly in accordance with manual. All repair practice by non-professional is prohibited.



## 2.2 SAFETY

- a. Please keep the main power supply switch far away from the children.
- b. When a power cut happens during operating, and later the power is restored, the heat pump will start up.
- c. Please switch off the main power supply in lightening and storm weather to prevent from machine damage that caused by lightning;
- d. Safety inspection must be carried before the maintenance or repair for heat pumps with R32 gas in order to minimize the risk.
- e. Installation and any repairing should be conducted in the area with good ventilation. The ignition source is prohibited during the inspection.
- f. If R32 gas leaks during the installation process, all operations must be stopped immediately and call the service center.

## 3 ABOUT YOUR HEAT PUMP

### 3.1 TRANSPORTATION

- a. Always keep upright

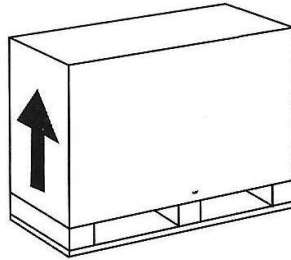

- b. Do not lift the water union  
(Otherwise the titanium heat exchanger inside the heat pump may be damaged)

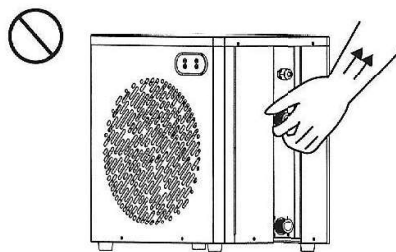

### 3.2 ACCESSORIES

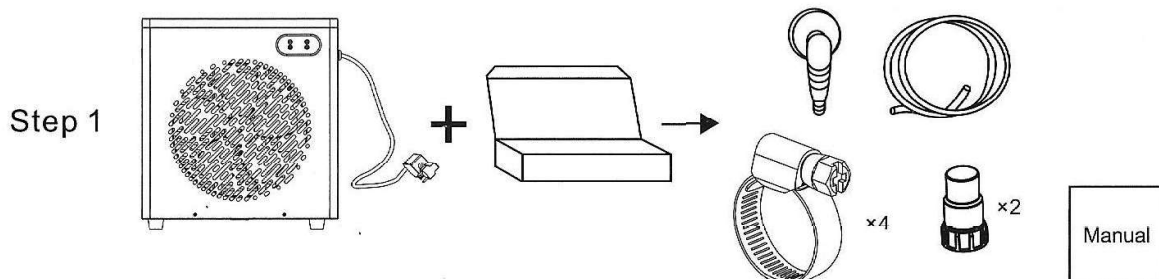

Step 2

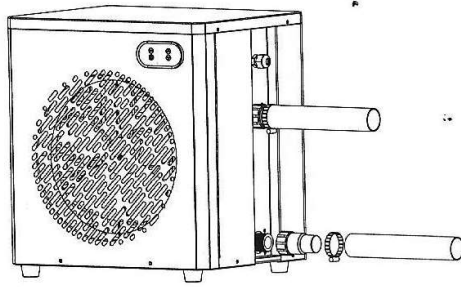

Connection of the condensate drainage kit:

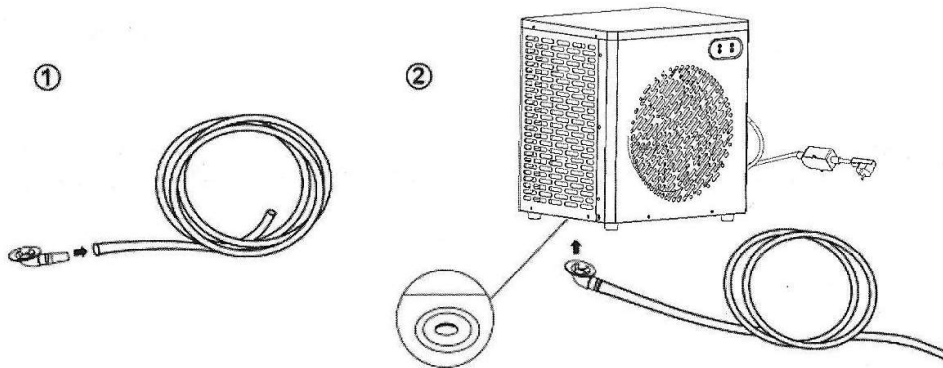

### 3.3 FEATURES

---

- a. Stable DC inverter compressor
- b. Smart defrost
- c. High-efficiency twisted titanium heat exchanger
- d. Low pressure protection
- e. Soft start & wide voltage application
- f. Stable inverter control system

### 3.4 OPERATING CONDITION AND RANGE

---

- a. To provide you comfort and pleasure, please set swimming pool water temperature efficiently and economically.
- b. The heat pump can work between air temperature 5°C ~ 43°C, and its ideal operation range is between air temperature 15°C ~ 25°C.
- c. Heating temperature setting range: 15°C ~ 40°C.

### 3.5 TECHNICAL PARAMETER

Model	LS03-IMN1-S4C6	LS04-IMN1-S4C6	LS05-IMN1-S4C6
<b>Performance condition: Air: 27°C / Water: 27°C / Humidity: 80%</b>			
Heating capacity (kW)	3.5	4.5	5.6
COP	11.2-5.4	10.1-5.2	11.1-6.0
Average COP at 50% Speed	8.1	8.6	9.5
<b>Performance condition: Air: 15°C / Water: 26°C / Humidity: 70%</b>			
Heating capacity (kW)	2.4	3.2	3.9
COP	7.6-4.1	7.7-4.2	7.4-4.0
Average COP at 50% Speed	5.7	6.0	6.7
<b>Technical specifications</b>			
Advised pool volume (m3) *	0~15	5~20	8~25
Operating air temperature (°C)	5°C-43°C		
Power supply	220-240V / 1Ph / 50/60Hz		
Refrigerant	R32		
Rated input power (kW)	0.33-0.8	0.38-0.95	0.41-1.05
Rated input current (A)	1.5-3.8	1.8-4.5	1.9-5.0
Maximum input current (A)	4.5	5.5	6
Power cord (mm <sup>2</sup> )	3x1.0	3x1.0	3x1.0
Sound level at 1m dB(A)	36.8~49	36.8~50	36.8~50
Sound level at 10m dB(A)	21~32.5	22~32.5	22~33.5
Advised water flow (m <sup>3</sup> /h)	1~2	1~2.5	2~3.5
Minimum water flow (m <sup>3</sup> /h)	1	1	2
Protection level	IPX4	IPX4	IPX4
Water connection (mm)	32/38		
R32 Net weight (g)	320	350	400
Net Weight (Kg)	24	25	26
Net dimension L×W×H (mm)	440x330x486	440x330x486	440x330x486

#### Remarks:

This heat pump is able to perform normal within air temperature of 5°C~43°C, efficiency will not be guaranteed if out of this range. Please take into consideration that the pool heat pump performance and parameters are different under various conditions.

Related parameters are subject to adjustment periodically for technical improvement without further notice. For more details, please refer to nameplate

### 3.6 DIMENSION

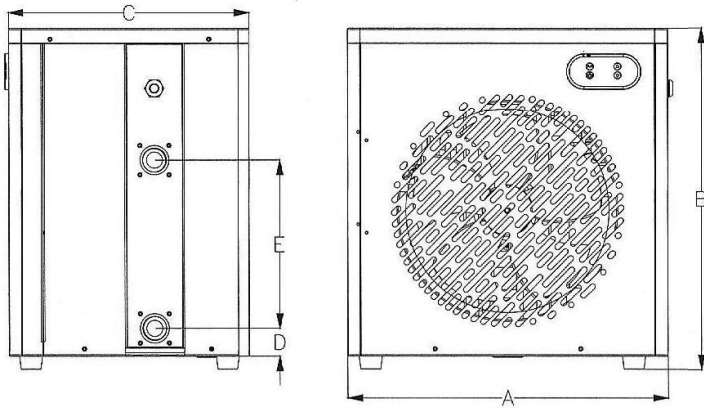

Size(mm) Model	Name	A	B	C	D	E
LS03-IMN1-S4C6		440	468	330	16	230
LS04-IMN1-S4C6		440	468	330	16	230
LS05-IMN1-S4C6		440	468	330	16	230

※ Above data is subject to modification without notice.

#### ⚠ NOTE

The picture above is the specification diagram of the pool heat pump, for technician's installation and layout reference only. The product is subject to adjustment periodically for improvement without further notice.

## 4 INSTALLATION GUIDANCE

### 4.1 INSTALLATION GUIDANCE

#### a. Heat pump location and installation reminder



The pool heat pump should be installed in a good ventilation area, with stable power supply and filter. The distance between heat pump and other objects like wall, bush or devices should be at least 0.5m, For indoor pool, please consult a professional installation technician.

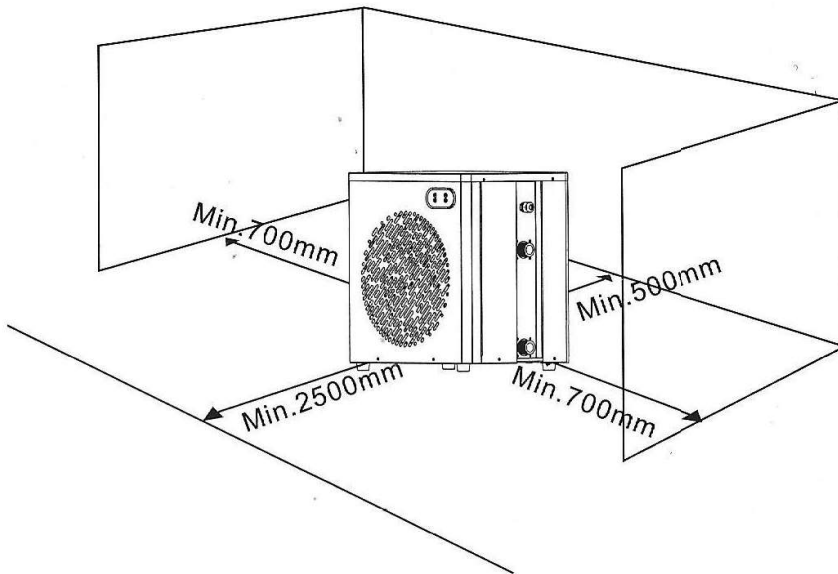

The distance between heat pump and the pool should be at least 2 meters.

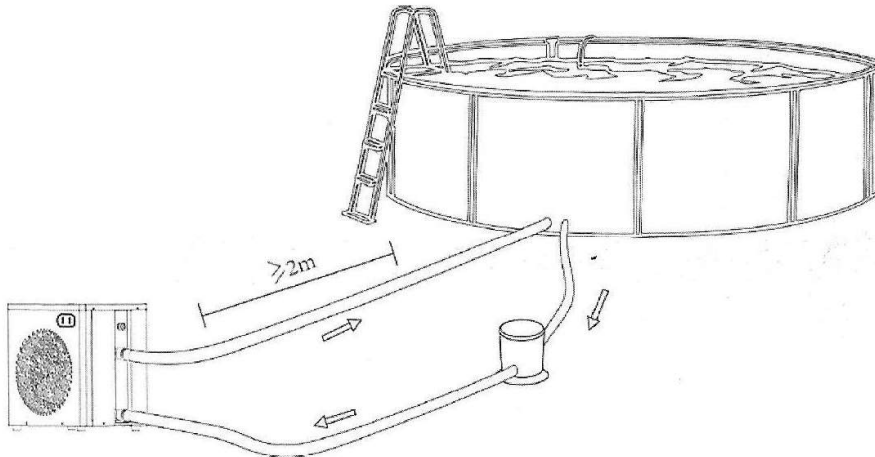

- 1) Please don't stack substances that will block air flow near inlet or outlet area, and there is no barrier within 0.5m behind the main machine and 2.5m before the main machine, or the efficiency of the heat pump will be reduced or even stopped.
- 2) The machine needs an appended pump (Supplied by the user). The recommended pump specification-flux: refer to Technical Parameter.
- 3) When the machine is running, there will be condensation water discharged from the bottom, please pay attention to it. Please hold the drainage nozzle (accessory) into the hole and clip it well, and then connect a pipe to drain the condensation water out.
- 4) Please ensure the order: when starting, start the filter pump before the heat pump, and when finishing, turn off the heat pump before the filter pump, otherwise it will damage the heat pump.
- 5) Depending on the initial temperature of the water in the swimming pool and the air temperature, it may take several days to heat the water to the desired temperature. A good swimming pool cover can dramatically reduce the required length of time. Isolation mats underneath will also reduce heat loss.



## 4.2 WIRING AND POWER SUPPLY

- Connect to appropriate power supply, the voltage should comply with the rated voltage of the products.
- Earth the machine well.
- Wiring must be handled by a professional technician according to the circuit diagram.
- Set leakage protector according to the local code for wiring (leakage operating current  $\leq 30\text{mA}$ ).
- The layout of power cable and signal cable should be orderly and not affecting each other.

## 4.3 REFERENCE FOR PROTECTING DEVICES AND CABLE SPECIFICATION

Model		LS03-IMN1-S4C6	LS04-IMN1-S4C6	LS05-IMN1-S4C6
Breaker	Rated current (A)	3.8	4.8	5.0
	Rated residual action current (mA)	10	10	10
Fuse (A)		8	9	10
Power cord (mm <sup>2</sup> )		3x1.0	3x1.0	3x1.0

\* Above data may be subject to modification, without prior notice.

### Note:

- The above data is adapted to a power cord  $\leq 10$  m. If the power cord is over 10m, the wire diameter must be increased.
- The RCD plug is not waterproof and must be protected against any damage and used in a dry environment.

### Attention:

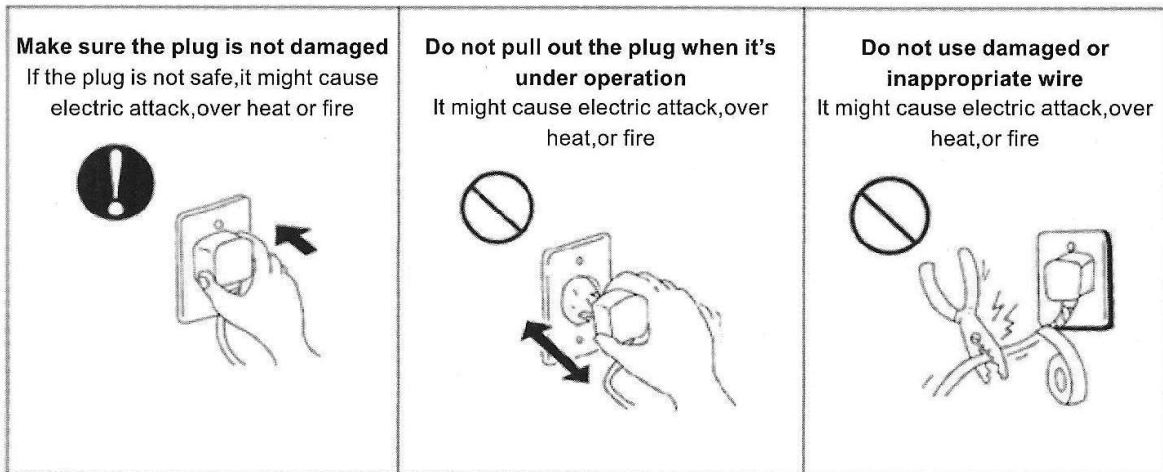

## 5 OPERATION GUIDANCE

### 5.1 KEY FUNCTION

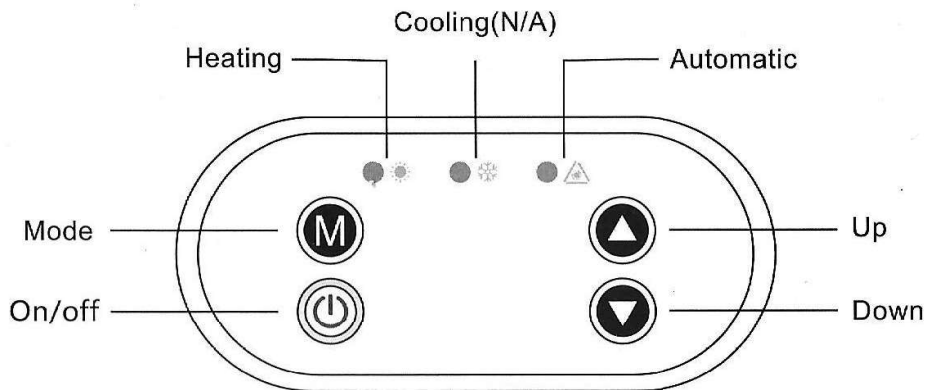

No.	Key	Function
1		Display heating function
2		Display cooling function(this unit has no cooling function)
3		Display automatic function
4		Press to turn on or off the heat pump
5		Press to select working mode
6		Press to increase the water temperature
7		Press to decrease the water temperature

### 5.2 TEMPERATURE DISPLAY

28°C is shown on the screen as below for your reference, only Celsius degree will be displayed:

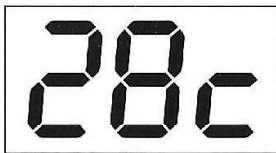



### 5.3 OPERATION INSTRUCTION



a. ON/OFF key

Turn on or off the heat pump. When the controller is off, only the water temperature is displayed and the mode cannot be switched. Shortly press the key, the controller will be turned on and the mode light before the last shutdown of the controller lights up.

b.   /Temperature setting

When the heat pump is on, press  or  to adjust the setting temperature of the water.

c. Status query function

In the water temperature display interface, press and hold the mode button for 3 seconds, all the mode lights flash once and then release the button to enter the status query interface. You can select the query parameters in turn by pressing the  or  button, and press the mode button  to check the value of the corresponding parameter.

d. Restore parameter to default value



When the heat pump is off, press and hold the on/off button  for 10 seconds and all mode lights flash three times, release the button, wait for "---" to be displayed, then the recovery is successful.

e. Defrosting

Auto defrosting

When machine is auto defrosting, " " will flash, and return to previous working mode when it finishes.

Manual defrosting

When the heat pump is on, in the water temperature display interface, press and hold  and  buttons at the same time for 5 seconds. After all the mode lights flash twice, release the button to enter the manual defrosting function. The main control board determines whether to enter the manual defrosting function according to the actual conditions. Heating light flashes continuously during defrost.

## 6 TESTING

### 6.1 INSPECT HEAT PUMP BEFORE USE

- The ventilating device and outlets are operating adequately, and are not obstructed.
- It's prohibited to install refrigeration pipe or components in corrosive environment.
- Double confirm the main machine power switch should be off.
- Inspect the air inlet and outlet.

### 6.2 LEAKAGE DETECTION NOTICE AND METHOD



- Leakage checking is prohibited in closed area.
- The ignition source is prohibited during the leakage inspection. A halide torch (or any other detector using a naked flame) shall not be used.
- Leakage detection fluids can be applied with most refrigerants but the use of detergents containing chlorine shall be avoided as the chlorine may react with the refrigerant and corrode the copper pipe.
- Vacuumize completely before welding. Welding can only be carried out by professional personnel in service center.
- Please stop using while gas leakage occur, and contact professional personnel in service center.

## 6.3 TRIAL

- a. The user must “Start the Pump before the Machine, and Turn off the Machine before the Pump”, or the machine will be damaged.
- b. Before start the heat pump, please check for any leakage of water.
- c. In order to protect the swimming pool heat pump, the machine is equipped with a time lag starting function, the fan will run 1 minute earlier than the compressor when starting the machine, and it will stop running 1 minute later than the compressor when power off the machine.
- d. After the swimming pool heat pump start up, please kindly checking for any abnormal noise from the machine.
- e. Set proper temperature in order to get comfortable water temperature to avoid overheating or overcooling.

## 7 MAINTENANCE



“CUT OFF” power supply of the heat pump before cleaning, examination and repairing

1. In winter season when you don't swim:
  - a. Cut off power supply to prevent any machine damage.
  - b. Drain water clear of the machine.
  - c. Cover the machine body when not in use.



Important:  
Unscrew the water nozzle of inlet pipe to let the water flow out.  
When the water in machine freezes in winter season, the titanium heat exchanger may be damaged.

2. Please clean this machine with household detergents or clean water, NEVER use gasoline, thinners or any similar fuel.
3. Check bolts, cables and connections regularly.
4. If repair or scrap is required, please contact authorized service center nearby.
5. Do not attempt to work on the equipment by yourself. Improper operation may cause danger.

## 8 TROUBLE SHOOTING FOR COMMON FAULTS

### 8.1 REPAIRING GUIDANCE



- a. If repair or scrap is required, please contact authorized service center nearby.
- b. Requirements for professional service personnel in service center.
- c. Any person who is involved with working on or breaking into a refrigerant circuit should hold a current valid certificate from an industry-accredited assessment authority, which authorizes their competence to handle refrigerants safely in accordance with an industry recognized assessment specification.
- d. Do not attempt to work on the equipment by yourself. Improper operation may cause danger.

- e. Strictly comply with the manufacturer's requirements when charging R32 gas and equipment maintenance. This chapter focuses on special maintenance requirements for swimming pool heat pump with R32 gas. Please refer to the technical service manual for detailed maintenance operation.
- f. Vacuumize completely before welding. Welding can only be carried out by professional personnel in service center.

## 8.2 FAILURE SOLUTION

Failure	Reason	Solution
Heat pump doesn't run	No power	Wait until the power recovers
	Power switch is off	Switch on the power
	Fuse burned	Check and change the fuse
	The breaker is off	Check and turn on the breaker
Fan is running but with insufficient heating	evaporator blocked	Remove the obstacles
	Air outlet blocked	Remove the obstacles
	3 minutes start delay	Wait patiently
Display normal, but no heating	Set temperature too low	Set proper heating temperature
	3 minutes start delay	Wait patiently
If above solutions don't work, please contact your installer with detailed information and your model number. Don't try to repair it by yourself.		

### Note:

If the following conditions happen, please stop the machine and cut off the power supply immediately, then contact your dealer:

1. Inaccurate switch action.
2. The fuse is frequently broken or leakage circuit breaker jumped.

## 8.3 PROTECTION & FAILURE CODE

Code	Failure description	Action
E03	AC current protection	Stop for protection
E04	AC voltage protection	Stop for protection
E05	DC voltage protection	Stop for protection
E06	Phase current protection	Stop for protection
E07	IBM over-temperature protection	Stop for protection
E09	Excessive exhaust protection	Stop for protection
E15	Refrigerating coil temp too high protection	Stop for protection
E17	Water flow protection	Stop for protection initiate again in a minute, lock after three times



<b>Code</b>	<b>Failure description</b>	<b>Action</b>
E19	Low voltage switch fault	Stop for protection
E23	Heating ambient temp. too low protection	Stop for protection
E24	Cooling ambient temp. too low protection	Stop for protection
E25	Internal cooling coil temp too low protection	Stop for protection
E26	AC Fan motor fault	Stop for protection
E33	Flow sensor malfunction	Stop for protection
E49	Water inlet sensor fault	Stop for protection
E50	Coil temp. sensor fault	Cancel the corresponding logical judgement
E51	Exhaust temp. sensor fault	Stop for protection
E52	Suction temp. sensor fault	Cancel the corresponding logical judgement
E53	Inside coil temp. sensor fault	Replace logical judgment with water outlet
E54	Ambient temp. sensor fault	Cancel the corresponding logical judgement
D17	Driver 1 IBM over-current protection	System 1 stop
D18	Driver 1 compressor drive failure (other drive failure except IPM)	System 1 stop
D19	Driver 1 compressor over current	System 1 stop
D22	Driver 1 IPM over heat protection	System 1 stop
D23	Driver 1 PFC failure	System 1 stop
D24	Driver 1 DC busbar over voltage	System 1 stop
D25	Driver 1 DC busbar under voltage	System 1 stop
D26	Driver 1 AC input voltage over-voltage / under-voltage	System 1 stop
D27	Driver 1 AC over input current stop	System 1 stop
D33	Driver 1 IPM temperature protection	System 1 stop
D34	Driver 1 DC fan motor 1 failure	System 1 stop
D36	Driver 1 transformer output 15V over-voltage / under-voltage protection	System 1 stop

## 9 SERVICE OPERATIONS



This heat pump contains a flammable refrigerant R32.

Any intervention on the refrigerant circuit is prohibited without a valid authorization. Before working on the refrigerant circuit, the following precautions are necessary for safe work.

Only persons authorized by an accredited agency certifying their competence to handle refrigerants in compliance with sector legislation should work on refrigerant circuits.

Servicing shall be performed only as recommended by the manufacturer.

Any person who is involved with working on or breaking into a refrigerant circuit should hold a current valid certificate from an industry-accredited assessment authority, which authorises their competence to handle refrigerants safely in accordance with an industry recognised assessment specification.

Servicing shall only be performed as recommended by the equipment manufacturer. Maintenance and repair requiring the assistance of other skilled personnel shall be carried out under the supervision of the person competent in the use of flammable refrigerants.

### 1. Checks to the area

Prior to beginning work on systems containing flammable refrigerants, safety checks are necessary to ensure that the risk of ignition is minimised. For repair to the refrigerating system, the following precautions shall be complied with prior to conducting work on the system.

### 2. Work procedure

The work must be carried out according to a controlled procedure, in order to minimize the risk of presence of flammable gases or vapors during the execution of the works.

### 3. General work area

All persons in the area must be informed of the nature of the work in progress. Avoid working in a confined area. The area around the work area should be divided, secured and special attention should be paid to nearby sources of flame or heat.

### 4. Verification of the presence of refrigerant

The area should be checked with a suitable refrigerant detector before and during work to ensure that there is no potentially flammable gas. Make sure that the leak detection equipment used is suitable for flammable refrigerants, i.e. it does not produce sparks, is properly sealed or has internal safety.

#### 5. Presence of fire extinguisher

If hot work is to be performed on the refrigeration equipment or any associated part, appropriate fire extinguishing equipment must be available. Install a dry powder or CO<sub>2</sub> fire extinguisher near the work area.

#### 6. No source of flame, heat or spark

It is totally forbidden to use a source of heat, flame or spark in the direct vicinity of one or more parts or pipes containing or having contained a flammable refrigerant. All sources of ignition, including smoking, must be sufficiently far from the place of installation, repair, removal and disposal, during which time a flammable refrigerant may be released into the surrounding area. Before starting work, the environment of the equipment should be checked to ensure that there is no risk of flammability. «No smoking» signs must be posted.

#### 7. Ventilated area

Make sure the area is in the open air or is properly ventilated before working on the system or performing hot work. Some ventilation must be maintained during the duration of the work.

#### 8. Controls of refrigeration equipment

When electrical components are replaced, they must be suitable for the intended purpose and the appropriate specifications. Only the parts of the manufacturer can be used. If in doubt, consult the technical service of the manufacturer.

The following controls should be applied to installations using flammable refrigerants:

- The size of the load is in accordance with the size of the room in which the rooms containing the refrigerant are installed;
- Ventilation and air vents work properly and are not obstructed;
- If an indirect refrigeration circuit is used, the secondary circuit must also be checked.
- The marking on the equipment remains visible and legible. Illegible marks and signs must be corrected;
- Refrigeration pipes or components are installed in a position where they are unlikely to be exposed to a substance that could corrode components containing refrigerant

#### 9. Verification of electrical appliances

Repair and maintenance of electrical components must include initial safety checks and component inspection procedures. If there is a defect that could compromise safety, no power supply should be connected to the circuit until the problem is resolved.

Initial security checks must include:

- That the capacitors are discharged: this must be done in a safe way to avoid the possibility of sparks;
- No electrical components or wiring are exposed during loading, recovery or purging of the refrigerant gas system;
- There is continuity of grounding.

#### 10. Initial safety checks shall include

- that capacitors are discharged: this shall be done in a safe manner to avoid possibility of sparking;
- that no live electrical components and wiring are exposed while charging, recovering or purging the system;
- that there is continuity of earth bonding.

#### 11. Repairs to sealed components

During repairs to sealed component, all electrical supplies shall be disconnected from the equipment being worked upon prior to any removal of sealed covers, etc. If it is absolutely necessary to have an electrical supply to equipment during servicing, then a permanently operating form of leak detection shall be located at the most critical point to warn of a potentially hazardous situation.

Particular attention shall be paid to the following to ensure that by working on electrical components, the casing is not altered in such a way that the level of protection is affected. This shall include damage to cables, excessive number of connections, terminals not made to original specification, damage to seals, incorrect fitting of glands, etc.

Ensure that apparatus is mounted securely.

Ensure that seals or sealing materials have not degraded such that they no longer serve the purpose of preventing the ingress of flammable atmospheres.

Replacement parts shall be in accordance with the manufacturer's specifications.

NOTE The use of silicon sealant may inhibit the effectiveness of some types of leak detection equipment. Intrinsically safe components do not have to be isolated prior to working on them.

#### 12. Repair to intrinsically safe components

Do not apply any permanent inductive or capacitance loads to the circuit without ensuring that this will not exceed the permissible voltage and current permitted for the equipment in use.

Intrinsically safe components are the only types that can be worked on while live in the presence of a flammable atmosphere. The test apparatus shall be at the correct rating.

Replace components only with parts specified by the manufacturer. Other parts may result in the ignition of refrigerant in the atmosphere from a leak.

### 13. Cabling

Check that cabling will not be subject to wear, corrosion, excessive pressure, vibration, sharp edges or any other adverse environmental effects. The check shall also take into account the effects of ageing or continual vibration from sources such as compressors or fans.

### 14. Detection of flammable refrigerants

Under no circumstances shall potential sources of ignition be used in the searching for or detection of refrigerant leaks. A halide torch (or any other detector using a naked flame) shall not be used.

### 15. Leak detection methods

The following leak detection methods are deemed acceptable for systems containing flammable refrigerants.

Electronic leak detectors shall be used to detect flammable refrigerants, but the sensitivity may not be adequate, or may need re-calibration. (Detection equipment shall be calibrated in a refrigerant-free area. Ensure that the detector is not a potential source of ignition and is suitable for the refrigerant used. Leak detection equipment shall be set at a percentage of the LFL of the refrigerant and shall be calibrated to the refrigerant employed and the appropriate percentage of gas (25% maximum) is confirmed.

Leak detection fluids are suitable for use with most refrigerants but the use of detergents containing chlorine shall be avoided as the chlorine may react with the refrigerant and corrode the copper pipe-work.

If a leak is suspected, all naked flames shall be removed/extinguished.

If a leakage of refrigerant is found which requires brazing, all of the refrigerant shall be recovered from the system, or isolated (by means of shut off valves) in a part of the system remote from the leak. Oxygen free nitrogen (OFN) shall then be purged through the system both before and during the brazing process.

### 16. Removal and evacuation

When breaking into the refrigerant circuit to make repairs - or for any other purpose - conventional procedures shall be used. However, it is important that best practice is followed since flammability is a consideration. The following procedure shall be adhered to:



1. remove refrigerant;
2. purge the circuit with inert gas;
3. evacuate;
4. purge again with inert gas;
5. open the circuit by cutting or brazing.

The refrigerant charge shall be recovered into the correct recovery cylinders. The system shall be "flushed" with OFN to render the unit safe. This process may need to be repeated several times. Compressed air or oxygen shall not be used for this task.

Flushing shall be achieved by breaking the vacuum in the system with OFN and continuing to fill until the working pressure is achieved, then venting to atmosphere, and finally pulling down to a vacuum. This process shall be repeated until no refrigerant is within the system. When the final OFN charge is used, the system shall be vented down to atmospheric pressure to enable work to take place. This operation is absolutely vital if brazing operations on the pipe work are to take place.

Ensure that the outlet for the vacuum pump is not close to any ignition sources and there is ventilation available.

#### 17. Charging procedures

In addition to conventional charging procedures, the following requirements shall be followed.

- Ensure that contamination of different refrigerant does not occur when using charging equipment. Hoses or lines shall be as short as possible to minimize the amount of refrigerant contained in them.
- Cylinders shall be kept upright.
- Ensure that the refrigeration system is earthed prior to charging the system with refrigerant.
- Label the system when charging is complete (if not already).
- Extreme care shall be taken not to overfill the refrigeration system.

Prior to recharging the system it shall be pressure tested with OFN. The system shall be tested on completion of charging but prior to commissioning. A follow up leak test shall be carried out prior to leaving the site.

#### 18. Decommissioning

Before carrying out this procedure, it is essential that the technician is completely familiar with the equipment and all its detail. It is recommended good practice that all refrigerants are recovered safely. Prior to the task being carried out, an oil and refrigerant sample shall be taken in case analysis is required prior to re-use of reclaimed refrigerant. It is essential that electrical power is available before the task is commenced.

- a) Become familiar with the equipment and its operation.
- b) Isolate system electrically.
- c) Before attempting the procedure ensure that.
  1. mechanical handling equipment is available, if required, for handling refrigerant cylinders:
  2. all personal protective equipment is available and being used correctly
  3. the recovery process is supervised at all times by a competent person;
  4. recovery equipment and cylinders conform to the appropriate standards.
- d) Pump down refrigerant system. if possible.
- e) If a vacuum is not possible, make a manifold so that refrigerant can be removed from various parts of the system.
- f) Make sure that cylinder is situated on the scales before recovery takes place.
- g) Start the recovery machine and operate in accordance with manufacturers instructions.
- h) Do not overfill cylinders. (No more than 80 volume liquid charge).
- i) Do not exceed the maximum working pressure of the cylinder, even temporarily.
- j) When the cylinders have been filled correctly and the process completed, make sure that the cylinders and the equipment are removed from site promptly and all isolation valves on the equipment are closed off.
- k) Recovered refrigerant shall not be charged into another refrigeration system unless it has been cleaned and checked.

#### 19. Labeling

Equipment shall be labeled stating that it has been de-commissioned and emptied of refrigerant. The label shall be dated and signed. Ensure that there are labels on the equipment stating the equipment contains flammable refrigerant.

#### 20 Recovery

When removing refrigerant from a system, either for the servicing or decommissioning, it is recommended good practice that all refrigerants are removed safely.

When transferring refrigerant into cylinders, ensure that only appropriate refrigerant recovery cylinders are employed. Ensure that the correct number of cylinders for holding the total system charge are available. All cylinders to be used are designate for the recovered refrigerant and labeled for that refrigerant (i.e. special cylinders for the recovery of Refrigerant). Cylinders shall be complete with pressure relief valve and associated shut-off valves in good working order. Empty recovery cylinders are evacuated and, if possible, cooled before recovery occurs.

The recovery equipment shall be in good working order with a set of instructions concerning the equipment that is at hand and shall be suitable for the recovery of flammable refrigerants. In addition, a set of calibrated weighing scales shall be available and in good working order. Hoses shall be complete with leak-free disconnect couplings and in good condition. Before using the recovery machine, check that it is in satisfactory working order, has been properly maintained and that any associated electrical components are sealed to prevent ignition in the event of a refrigerant release. Consult manufacturer if in doubt.

The recovered refrigerant shall be returned to the refrigerant supplier in the correct recovery cylinder, and the relevant Waste Transfer Note arranged. Do not mix refrigerants in recovery units and especially not in cylinders.

If compressors or compressor oils are to be removed, ensure that they have been evacuated to an acceptable level to make certain that flammable refrigerant does not remain within the lubricant. The evacuation process shall be carried out prior to returning the compressor to the suppliers. Only electric heating to the compressor body shall be employed to accelerate this process.

When oil is drained from a system, it shall be carried out safely.





GUANGDONG LASWIM WATER ENVIRONMENT EQUIPMENT CO., Ltd



To scan QR code for more information.  
For more information please visit [www.laswimwater.com](http://www.laswimwater.com)

202204