

Operation Manual pH/ORP and Temperature Transmitter

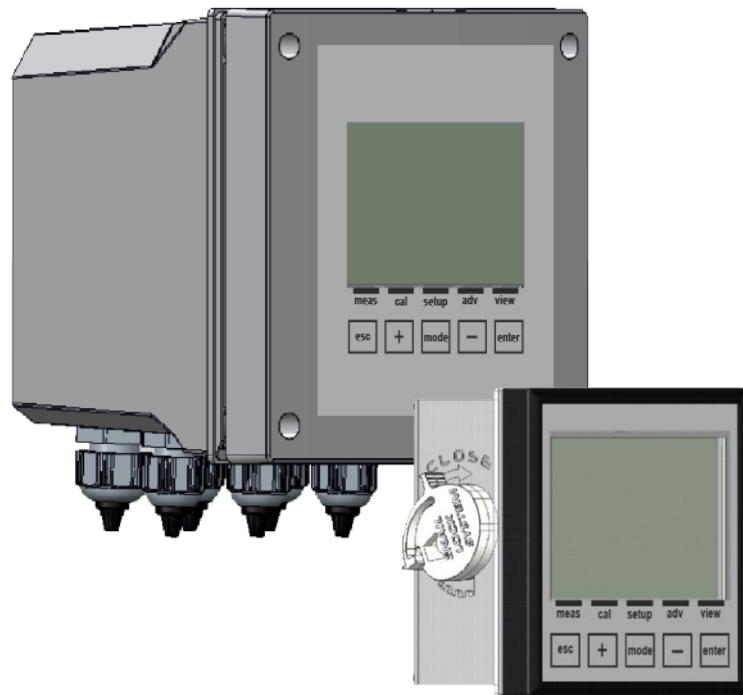

GENERAL	4
INFORMATION REGARDING THE MANUAL	4
LIMITATIONS OF USE AND SAFETY PRECAUTIONS	4
INFORMATION ON RECYCLING AND USE OF MATERIALS.....	6
GENERAL DESCRIPTION	7
MEASURING PRINCIPLES	7
MAIN CHARACTERISTICS.....	9
CONTROLS, INDICATORS AND CONNECTIONS.....	10
GRAPHIC DISPLAY	11
INSTALLATION	12
INSTALLING THE CENTRAL UNIT ON A WALL	12
INSTALLING THE CENTRAL UNIT ON AN ELECTRICAL PANEL.....	13
CONNECTION TO THE POWER SUPPLY	14
CONNECTION TERMINAL BLOCK FOR THE WALL MOUNTED DEVICE	16
STARTUP.....	18
ALARMS MENU.....	19
INFO MENU.....	19
CALIBRATION MENU (INDEX MENU 1).....	20
PH CALIBRATION PROCEDURE	21
ORP CALIBRATION PROCEDURE	26
SETUP MENU (INDEX MENU 2)	30
SETUP MENU \ RELAY 1 (ONE) (INDEX MENU 2A).....	31
SETUP MENU \ RELAY 2 (TWO) (INDEX MENU 2B).....	32
SETUP MENU \ SSR1 OUTPUT (INDEX MENU 2C)	33
SETUP MENU \ MA1 OUTPUT (INDEX MENU 2D)	34
ADVANCED MENU (MENU INDEX 3)	35
ADVANCED MENU \ LANGUAGE (INDEX MENU 3A)	36
ADVANCED MENU \ PASSWORD (INDEX MENU 3B)	37
ADVANCED MENU \ DISPLAY (INDEX MENU 3C).....	38
ADVANCED MENU \ CHEMICAL MEASURE (INDEX MENU 3D)	39
ADVANCED MENU \ TEMPERATURE MEASURE (INDEX MENU 3E).....	40
ADVANCED MENU \ ALARMS CONFIGURATION (INDEX MENU 3F).....	41
ADVANCED MENU \ OUTPUTS CONFIGURATION (INDEX MENU 3G)	42
ADVANCED MENU \ CONTROL PANEL (INDEX MENU 3H)	43
ADVANCED MENU \ STATISTICS (INDEX MENU 3I).....	43
ADVANCED MENU \ RESET INSTRUMENT (INDEX MENU 3L).....	44
ADVANCED MENU \ FIRMWARE REVISION (INDEX MENU 3M)	44
VIEW MENU (INDEX MENU 4).....	45
GENERAL SPECIFICATIONS	46
MECHANICAL SPECIFICATIONS FOR VERSION 1/4DIN	46
MECHANICAL SPECIFICATIONS FOR VERSION 1/2DIN	46
ENVIRONMENTAL SPECIFICATIONS FOR VERSION 1/2DIN & 1/4DIN.....	46
ELECTRICAL SPECIFICATIONS	47

ANNEX A: ON/OFF RELAY SETUP	48
ANNEX A: ON/OFF RELAY SETUP WITH OFA FUNCTION.	49
ANNEX B: TIMED RELAY SETUP	50
ANNEX B: TIMED RELAY SETUP WITH OFA FUNCTION.	51
ANNEX C: PROPORTIONAL (PWM) RELAY SETUP.	52
ANNEX C: PROPORTIONAL (PWM) RELAY SETUP WITH OFA FUNCTION	53
ANNEX D: RELAY 2 SETUP FOR AUTOMATIC WASHING	54
ANNEX E: RELAY 2 SETUP TO REPEAT REMOTE ALARM.....	55
ANNEX F: SSR1 SETUP	56
ANNEX G: MA1 SETUP	57
ANNEX H: WIRING EXAMPLES.....	58
ANNEX I: TROUBLESHOOTING	60
ANNEX L: DEFAULT PARAMETERS TABLE AND RESET TO DEFAULT	61
RESET THE DEFAULT PARAMETERS OF THE INSTRUMENT	64



Note: All the strings representing programming menus in this manual are indicative only. The strings displayed by the instrument have been shortened for proper readability and viewing on the display.

GENERAL

INFORMATION REGARDING THE MANUAL

Compliance with the operative procedures and the precautions described in this manual is an essential requirement for the correct operation of the instrument and to guarantee total operator safety.

Before using the instrument, the manual must be read in all of its parts, in the presence of the instrument itself, in order to ensure that the operating modes, the controls, the connections to the peripheral equipment and the precautions for safe and correct use are clearly understood.

The user manual must be stored, integral and legible in all parts, in a safe place which can be quickly and easily accessed by the operator during installation, use and/or installation revision operations.

CONVENTIONS

The present user manual uses the following conventions:

NOTE



The notes contain important information to be highlighted in comparison to the rest of the text. These generally contain information that is useful to the operator to carry out and optimize operating procedures of the equipment in a correct manner.

WARNING



Warning messages appear in the manual before procedures or operations that must be observed in order to avoid any possible losses of data or damages to the equipment.

ATTENTION



Attention messages appear in the manual in correspondence to description of procedures or operations which, if carried out incorrectly, may cause damages to the operator or users.

LIMITATIONS OF USE AND SAFETY PRECAUTIONS

In order to guarantee operator safety and correct device functionality, all of the usage limitations and precautions listed below must be respected:

ATTENTION



Make sure that all the safety requirements have been met before using the device. The device must not be powered on or connected to other devices until all of the safety conditions have been met.

ELECTRICAL SAFETY

ATTENTION



All of the control unit's connections are isolated from the grounding system (non-insulated grounding conductor).
DO NOT connect any of these connections to the grounding connector.

In order to guarantee maximum conditions of safety for the operator, it is recommended to follow all of the indications listed in this manual.

- **Power the device only using a mains power supply that complies with the device's specifications: 230Vac, 115Vac or 24Vac 50/60Hz.**
- **Replace any damaged parts immediately.** Any cables, connectors, accessories or other parts of the device which are damaged or not functioning properly must be replaced immediately. In such cases, contact your nearest authorized technical assistance center.
- **Only use specified accessories and peripherals.** In order to guarantee all of the safety requirements, the device must only be utilized in conjunction with the accessories specified in this manual, which have been tested for use with the device itself. The use of accessories and consumption materials from other manufacturers or not specifically recommended by supplier will not guarantee the safety and correct operation of the equipment. Only use peripherals that comply with the regulations of their specific categories.

SAFETY OF THE OPERATING ENVIRONMENT

- The panel of the control unit is resistant to liquids. The device must be protected against drips, sprays and/or immersion and should not be used in environments where such risks are present. Any devices into which liquids may have accidentally penetrated must be immediately shut off, cleaned and inspected by authorized and qualified personnel.
- The transparent panel should be closed once the device has been programmed.

Protection

For **Wall Mounted (1/2 DIN)**

- IP65 Complete
- EMI /RFI CEI EN55011 - 05/99 Class A

For **Panel Mounted (1/4 DIN)**

- IP65 Front and IP20 Back
- EMI /RFI CEI EN55011 - 05/99 Class A

The device must be utilized within the specified environmental temperature, humidity and pressure limits. The instrument is designed to operate under the following environmental conditions:

- | | |
|---|-------------------------|
| – Temperature of the working environment | -10 ÷ +50°C |
| – Storage and transport temperature | -25°C ÷ +65°C |
| – Relative humidity Box 96x96 (1/4 DIN) | 0% ÷ 95% Non-Condensing |
| – Relative humidity Box 144x144 (1/2 DIN) | 0% ÷ 100% Condensing |

ATTENTION

The device must be perfectly inserted into the system.

The system must be maintained operational in full compliance with the foreseen safety regulations.

The parameters set on the analyzer's control unit must comply with the current regulations.

The control unit's malfunction signals must be located in an area that is constantly supervised by the system's maintenance personnel or operators.

Failure to respect even just one of these conditions could cause the control unit's "logic" to operate in a potentially dangerous manner for the users of the service.

In order to avoid any potentially dangerous situations, therefore, the system's service and/or maintenance personnel are advised to work with the utmost care and to signal any alterations in the safety parameters in a timely manner.

As the above issues cannot be monitored by the product in question, the manufacturer shall bear no responsibility for any property damage or personal injury which may result from such malfunctions.



ATTENTION SYMBOL

The symbol illustrated below represents the **ATTENTION** symbol and reminds the operator that he should read the user manual for important information, advice and suggestions regarding the correct and safe use of the equipment.



In particular, when it is positioned close to connection points to cables and peripherals, the symbol in question refers to careful reading of the user manual for instructions related to the nature of such cables and peripherals and the methods for correct and safe connection.

For the position of the ATTENTION symbols on the equipment, refer to Chapter 2 "Controls, Indicators and Connections" and Chapter 3 "Installation" of this user manual. The reproductions of equipment panels, with relative commands, connections, symbols and labels are provided in this chapter. Each attention symbol is accompanied by a detailed explanation of its meaning.

PLATE DETAILS

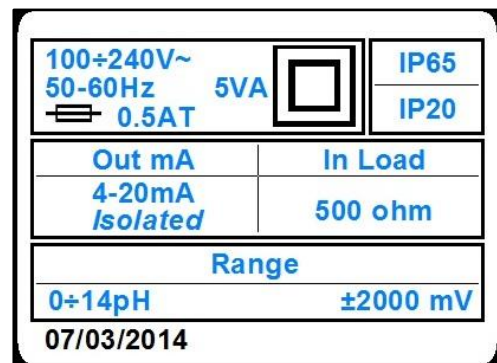
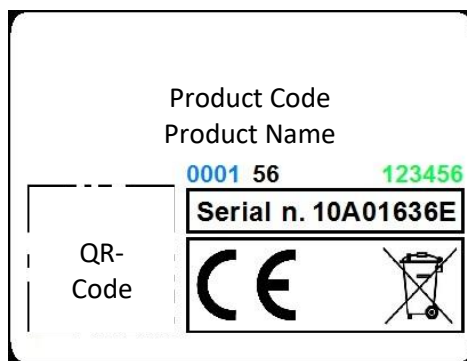

INFORMATION ON RECYCLING AND USE OF MATERIALS

The supplier, in accordance with specific European regulations, aims at constant improvement of development and of production procedures of its equipment with the objective of drastically reducing the negative impact on the environment caused by parts, components, consumption materials, packaging and the equipment itself at the end of its life cycle.

The packages are designed and produced to allow the reuse or recovery, including recycling, of the great part of the materials and to minimize the amount of waste or residues to be disposed. In order to assure a correct environmental impact, the equipment has been designed with the smallest circuit possible, with the lowest differentiation of materials and components, with a selection of substances that guarantee utmost recycling and maximum reuse of the parts and waste disposal free from ecological risks.

The equipment is made in such a way as to guarantee the easy separation or dismantling of the materials containing contaminants in comparison with others, in particular during maintenance operations and the replacement of components.

ATTENTION



The disposal/recycling of packages, consumption materials and of the equipment itself at the end of its life cycle must be carried out in accordance to the standards and regulations currently in force in the country where the equipment is used.

SPECIAL ATTENTION TO CRITICAL COMPONENTS

The instrument is provided with a liquid crystal display LCD, which contains small amounts of toxic materials.

GENERAL DESCRIPTION

The analyzer treated in this manual consists of an Electronic Control Unit and a Technical Manual. The Control Unit can be either panel mounted or wall mounted, at a maximum distance of 15 meters from the probe.

It is powered from the mains (230Vac, 115Vac or 24Vac 50/60Hz), with a power consumption of 3.6VA, through a linear power supply.

This device has been designed to analyze ON-LINE the pH/ORP values in different applications:

- Biological Oxidation Plants
- Treatment and Discharge of Industrial Water
- Fish Farming
- Primary or Drinking Water

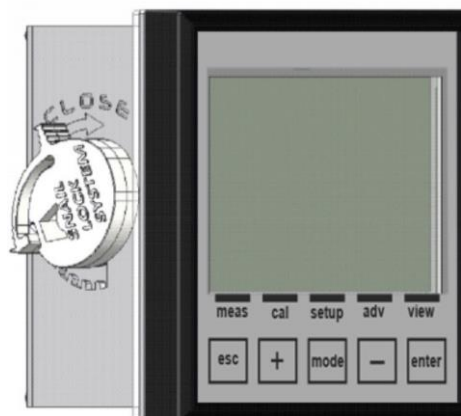

Figure 1 – Wall mounted Central Unit for pH/ORP and Temperature Measures

MEASURING PRINCIPLES

pH METER

Instrument designed to measure the acidity of a liquid, that is to say the ability of a substance to send into solution Hydrogen ions (H^+). The measure unit of this property is the pH (abbreviation for potential Hydrogenium) and represents the inverse of the decimal logarithm of the H^+ ions concentration present into solution. For the pure, water at an ambient temperature, the value described above is equal to 7. Are considered basic solutions those solutions with a pH greater than 7 and acidic solutions the solutions with a pH lower than 7. The extremes of the scale are pH=0 for pure acids and pH=14 for pure bases.

For measuring the pH value there are available electrochemical systems, test strips, indicators or colorimeters. Of all these methods, only the electrochemical measure leads to well-defined results. Such a measure is performed by means of a pH electrode. The pH electrode is an electrochemical sensor consisting of a measuring electrode and a reference electrode. The voltage present on a membrane varies according to the pH value of the test solution.

The pH electrodes currently in use are manufactured to indicate a value of pH=7 in the presence of a voltage equal to 0 mV to the membrane. The more the value deviates from pH=7, the greater is the voltage of the signal. The pH meter determines the pH value according to this signal.

ORP METER

Instrument designed to measure the Oxidation Reduction Potential (ORP) that indicates the ability of a donor element (reducing) to exchange electrons with an acceptor element (oxidant) measured through the potential assumed by an indifferent electrode (platinum/gold) immersed on the solution containing the oxidized or reduced form, compared to an electrode arbitrarily chosen as zero electrode. The measure unit is Volt, but is being commonly used one of its submultiples, millivolt ($mV = V \times 10^{-3}$). A few examples of applications of these measures are: the control of the denitrification of wastewaters (determination of the oxidation number), the monitoring of the effect of disinfection of drinking water or swimming pools water and even for decontamination in galvanic processes.

The measure takes place by means of an ORP electrode. As in the case of the pH electrode, this sensor consists of a measuring electrode and a reference electrode. The measuring function is carried out, however, in this case, not by a glass membrane but by a membrane made of platinum (or gold). The tendency of ions in solution to absorb or diffuse electrons determines the potential of the platinum and therefore the voltage of the electrode. The usual electrodes in use nowadays are equipped with a reference electrode of silver/silver chloride (UB), instead of a hydrogen electrode (UH), this means that the voltage indicated is relative to this system.

MAIN CHARACTERISTICS

- pH/ORP Measure
- Temperature Measure with PT100 / PT1000 Probe
- Automatic Temperature Compensation
- Programming keyboard with 5 keys
- Graphic Display, 128x128 pixels, with white backlight
- 1 Programmable Analog Output
- 1 Frequency Programmable Digital Output
- 2 Relay Outputs for Intervention Thresholds, Wash and Remote Alarm.
- 1 Digital Input for blocking the dosages

The technical specifications of the analyzer are listed in the following table.

TECHNICAL SPECIFICATIONS FOR THE pH MEASURE

Measure Range	0.00 ÷ 14.00pH
Resolution	± 0.01pH
Precision	± 0.10pH

TECHNICAL SPECIFICATIONS FOR THE ORP MEASURE

Measure Range	± 2000mV
Resolution	± 1mV
Precision	± 5mV

TECHNICAL SPECIFICATIONS FOR THE TEMPERATURE MEASURE (SECONDARY)

Sensor	PT100/PT1000
Measure Range	0 ÷ +100°C
Resolution	± 0.1°C (°F)
Precision	± 1.0°C (±1.8°F)

OPERATING SPECIFICATIONS

Power Supply	230Vac, 115Vac or 24Vac 50/60Hz
Power Consumption	3.6VA
Relay Outputs:	
Alarms:	
Function	Delay, Faults and Min./Max
Delay time	1÷3600sec
Threshold disabling	Enable / Disable
Relay function	Closed / Open
	For Alarm and Wash it is used the relay n. 2 with normally open contact.
Analog Outputs:	
Outputs	n.1 4-20mA Programmable
Maximum Load	500 Ohm
NAMUR Alarm Output	3.6 mA or 22 mA
Hold Alarm Value	

CONTROLS, INDICATORS AND CONNECTIONS

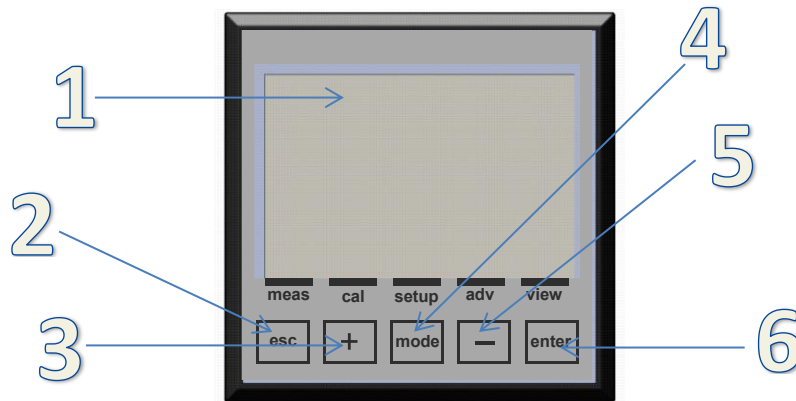

Figure 2 – Instrument

1. Visualizer with LCD Display
2. ESC key: Reject parameter or exit the programming menu
3. UP key: Increase value
4. MODE key: Select menu with icon on the status bar
5. DOWN key: Decrease value
6. ENTER key: Confirm parameter or access the programming menu

GRAPHIC DISPLAY SUBDIVISION AREAS IN RUN MODE

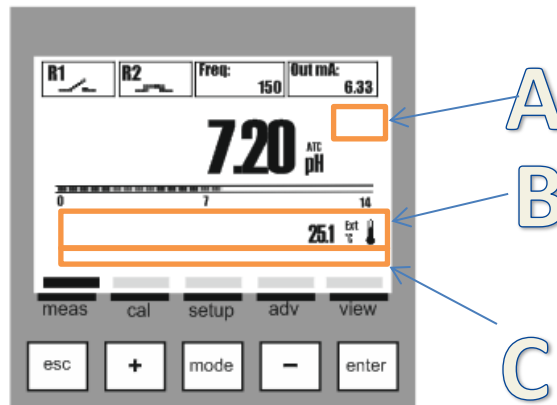

Figure 3 – Graphic Display - Subdivision Areas

In the standard view of the instrument we have three areas, as follows:



- A) Service icons such as Danger, Wait Time, Automatic Temperature Compensation ATC or Manual Temperature Compensation MTC.
- B) Text messages for Alarms and operation information or temperature value with external sensor (ext) or manually set value (man).
- C) Menu name associated to the icon on the status bar.

GRAPHIC DISPLAY

The graphic display allows a series of views for the various menus, for programming and for viewing during operation (run).

LIST OF THE MAIN MENUS

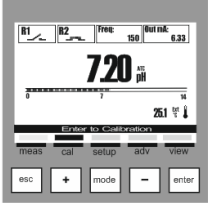
The following table shows the screens visualized on the display representing the different menus.

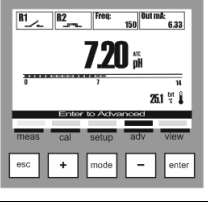
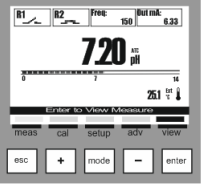
VISUALIZATION ON THE GRAPHIC DISPLAY	DESCRIPTION
	VIEW MEASURE
	CALIBRATION MENU Electrode Calibration Procedure
	SETUP MENU Output Parameters Setup Procedure
	ADVANCED MENU Device Setting Menu
	VIEW MENU Measure Visualization Setting



Note: Automatic exit from menu after 5 minutes of inactivity without saving data.

INSTALLATION

Before installing, read carefully what is written below.

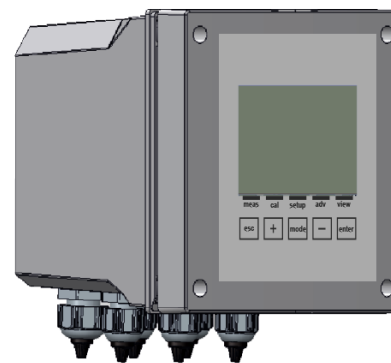

INSTALLING THE CENTRAL UNIT ON A WALL

The wall must be very smooth to allow the perfect adhesion of the central unit.

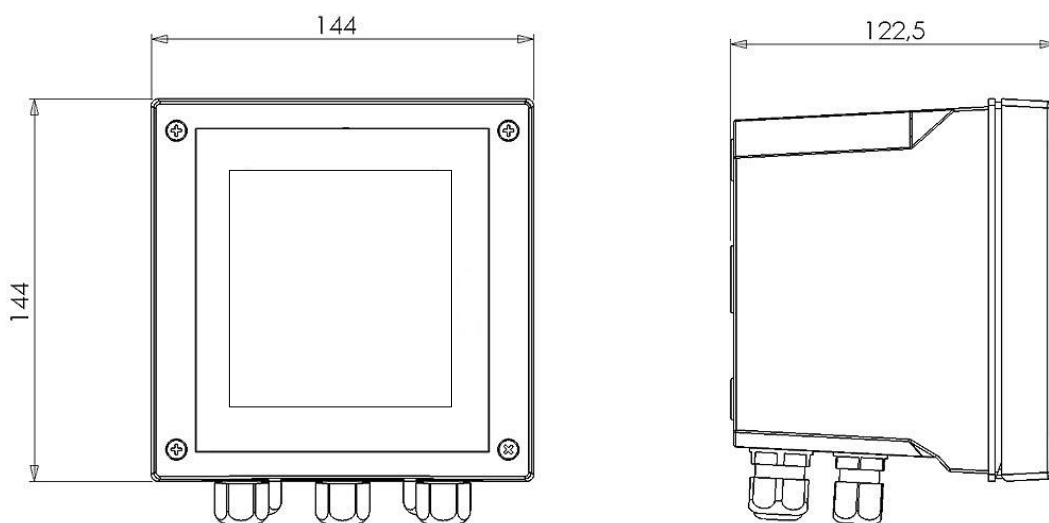

Figure 4 – Dimensions and footprint for wall mounted central unit

Mechanical Dimensions	
Dimensions (L x H x P)	144x144x122.5mm
Fixing depth	122.5mm
Material	ABS
Mounting	Wall
Weight	0.735 Kg
Front Panel	UV Resistant Polycarbonate

Open the instrument, drill the necessary holes and fasten the instrument to the wall. Cover the holes internally with the corresponding caps supplied with the instrument.

The cable glands for the electrical connections are located on the lower part of the control unit and therefore, in order to facilitate the connections, any other devices must be positioned at least at 15 cm away.

Protect the device against any drips and/or sprays of water from adjacent areas during the programming and calibration phases.

INSTALLING THE CENTRAL UNIT ON AN ELECTRICAL PANEL

The wall must be very smooth to allow the perfect adhesion of the electrical panel where the central unit will be fitted.
 The fixing depth of the panel must be at least 130 mm.
 The thickness of the panel must not exceed 5 mm.
 The panel cutout must comply with the following layout:

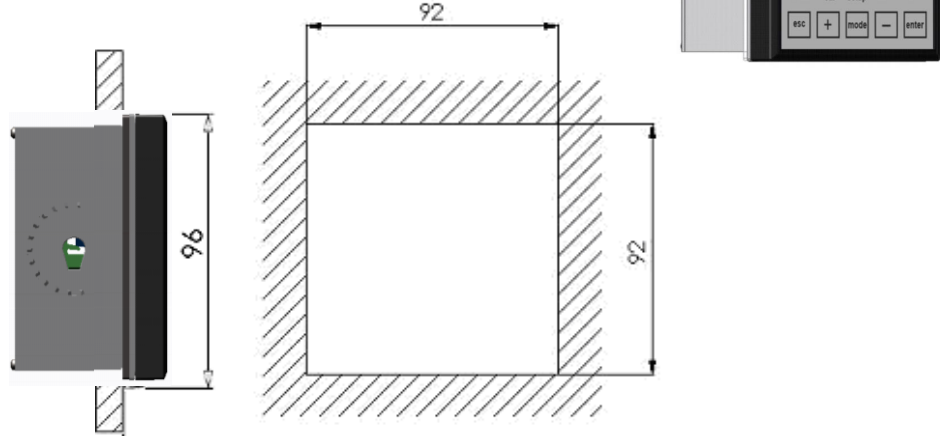

Figure 5 – Panel cutout and dimensions

Mechanical Dimensions	
Dimensions (L x H x P)	96x96x42mm
Fixing depth	130mm
Material	ABS
Mounting	Panel
Weight	0.310 Kg
Front Panel	UV Resistant Polycarbonate



The central unit can be locked on the panel using the two clamps supplied with the unit, inserted in their seats and locked with corresponding screws.

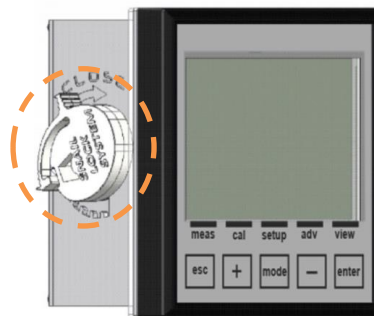

Figure 6 – Panel Mounted Central Unit with Snail Lock System

CONNECTION TO THE POWER SUPPLY

If possible, keep any high power cables away from the instrument and its connection cable (these could cause inductive disturbances, especially for the analogical part of the system).

Use an alternating 230Vac, 115Vac or 24Vac 50/60Hz power supply – or as specified on the plate. The power supply must be as stabilized as possible.

Absolutely avoid connecting the device to rebuilt power supplies, using transformers for example, where the same power supply is also used to power other systems (perhaps of an inductive typology); this could lead to the generation of high voltage spikes which, once emitted, are difficult to block and/or eliminate.

ATTENTION



The electrical line must be equipped with an appropriate circuit breaker, in compliance with the proper installation standards

It is nevertheless always a good idea to check the quality of the grounding connector. In industrial facilities, it is not uncommon to find grounding connectors that cause electrical disturbances instead of preventing them; wherever doubts should arise regarding the quality of the facility's grounding connectors, it is better to connect the control unit's electrical system to a dedicated grounding rod.

Electric connections to the dosing systems (Utilities)

ATTENTION



Before connecting the instrument to the external Utilities, make sure that the electrical panel is turned off and that the wires from the Utilities are not live.

The term "Utilities" refers to the relay outputs used in the control unit

- (SET1) for the operation of dosing pumps or control
- (SET2) for the operation of dosing pumps or control
- (ALARM) alarm command sent by the instrument to siren and/or flashing light
- (WASH) command to the washing device

WARNING



With a resistive load, each relay contact can sustain a maximum current of 5 Ampere at max. 230V.

ATTENTION



When a relay output is used to drive a 3rd party device with an inductive/capacitive load input (such as contactors, motors, etc.), a transient protection is highly recommended. Check 3rd party device's options. (See Figure 7)



Figure 7 – Transient protection

ATTENTION



Keep relay's output cable segregate from any other cable connected to the unit (see Figure 8a). 90° crossing between cables is allowed (see Figure 8b).

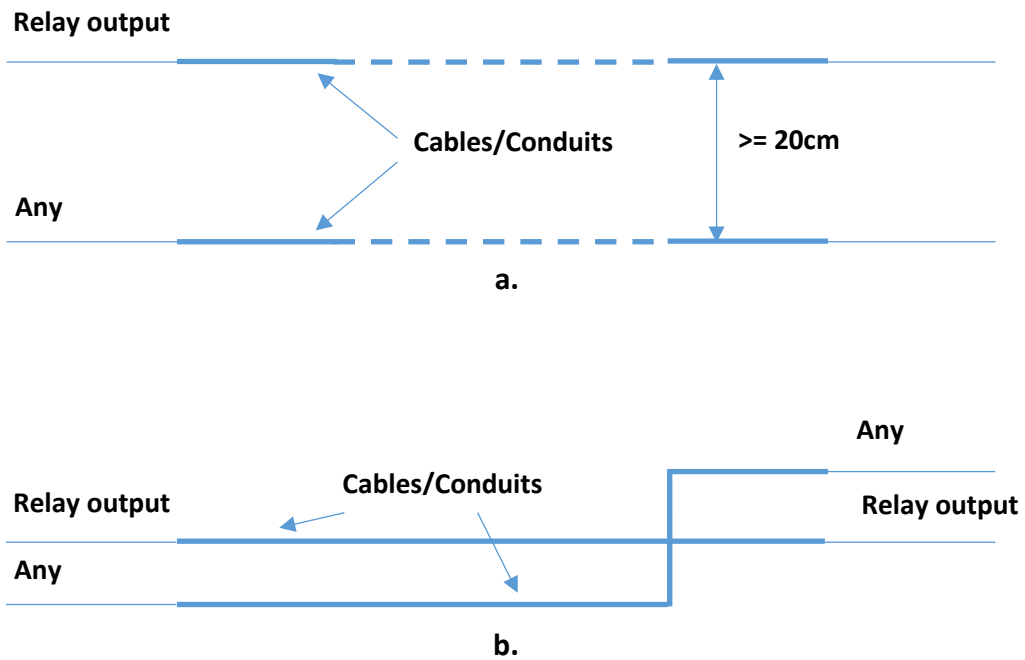
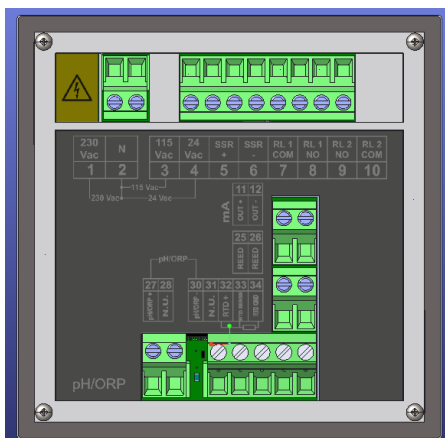

Figure 8 – Relay cable segregation

CONNECTION TERMINAL BLOCK FOR THE WALL MOUNTED DEVICE



N° (TERMINAL)	SYMBOLS	DESCRIPTION
1	230 Vac	Power supply 230 Vac (Phase)
2	N	Power supply (Neutral)
3	115 Vac	Power supply 115 Vac (Phase)
4	24 Vac	Power supply 24 Vac (Phase)
5	SSR (+)	Frequency Output (SSR +)
6	SSR (-)	Frequency Output (SSR -)
7	RL1 COM	Relay 1 COM Contact
8	RL1 NO	Relay 1 NO Contact
9	RL2 NO	Relay 2 NO Contact
10	RL2 COM	Relay 2 COM Contact
11	OUT (+)	Current Output (OUT mA +)
12	OUT (-)	Current Output (OUT mA -)
13-24	NOT PRESENT	NOT PRESENT
25	REED	REED Sensor Input (+)
26	REED	REED Sensor Input (-)
27	pH / ORP (+)	pH/ORP Probe Input (+)
28	N.U.	NOT USED
29	NOT PRESENT	NOT PRESENT
30	pH / ORP (-)	pH/ORP Probe Input (-)
31	N.U.	NOT USED
32	RTD (+)	PT100 or PT1000 Temperature Probe Input
33	RTD SENSE	PT100 or PT1000 Temperature Probe Input
34	RTD GND	PT100 or PT1000 Temperature Probe Input

Terminal block connections

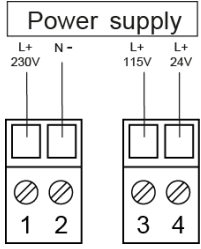
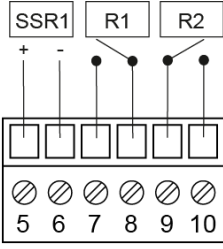
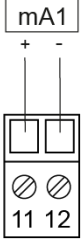
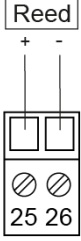
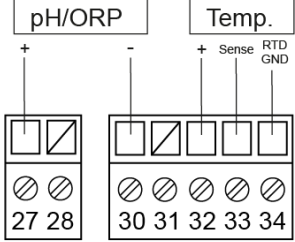
Description	Graphic
<p>Instrument Power Supply Input: 230Vac, 115Vac or 24Vac 50/60Hz Note: Check the product label.</p>	
<p>Outputs: SSR1: Solid State Relay (60Vac/dc, 100mA) R1 and R2: Electromechanical Relays (250Vac or 30VDC, 5A Resistive)</p>	
<p>Outputs: mA1: Current Outputs 4÷20mA (500 ohm)</p>	
<p>Inputs: Reed: Dry Contact Signal Input</p>	
<p>Inputs: pH/ORP: pH and ORP Measure Input Temp: Temperature Measure Input PT100 or PT1000</p>	

(Note: See ANNEX H for Wiring Examples)

pH/ORP PROBE CONNECTION



Turn off the instrument. Connect the cable of the electrode to the terminal block of the instrument observing the polarity indicated above.

The maximum length of the pH/ORP electrode cable (as a single element) must not exceed **10 meters**. It is also a good idea not to pass the cable near high power or inverter cables in order to avoid interference problems with the measure.

STARTUP

The instrument performs a hardware test of the internal memory and displays the message "**Read data memory**"

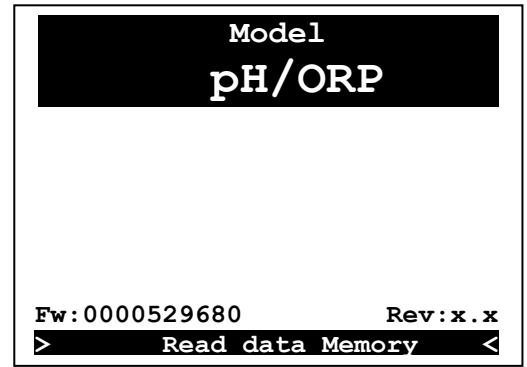

Wait

The instrument enables all the measure functions within 5 seconds.

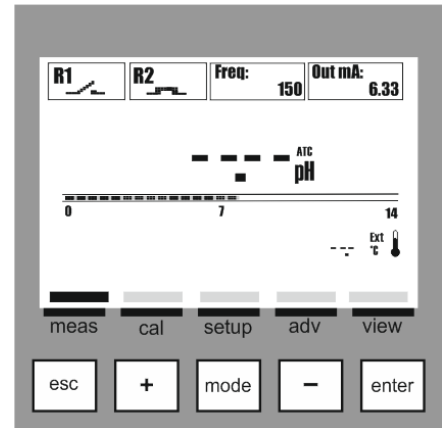

View Measure and Outputs Activation

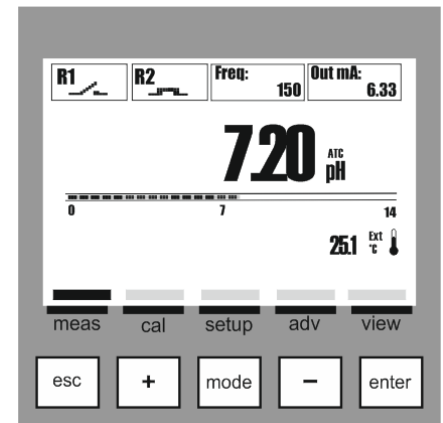



ALARMS MENU

On **View measure** mode there is available an alarm menu which displays the alarm status by pressing the **Enter** key; the **Alarms Menu** consists of four (4) items or sub-menus:

- A: View Log:** list of all recorded alarms, starting with the most recent (Max 48 items)
- B: Reset Log:** deletes all alarm events
- C: Reset OFA:** deletes the OFA alarm and resets the counter
- D: Reset RL2** (used as alarm):

Scroll through the menu using the **(+)** or **(-)** key, select the item and confirm with the **Enter** key.

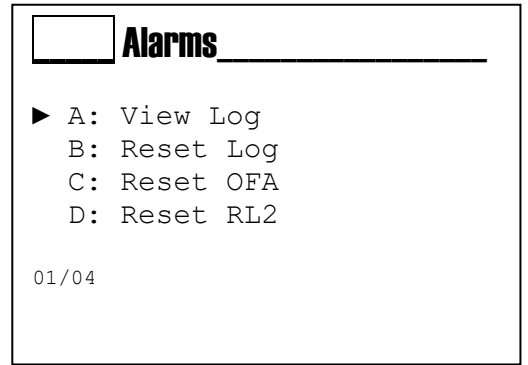

INFO MENU

In **View measure** mode, press the **ESC** key to access the **Info** menu.

Select the item "Download Manual" and press the **Enter** key.



On the screen will be displayed the WEB Link with which you can start downloading the user manual in pdf format.

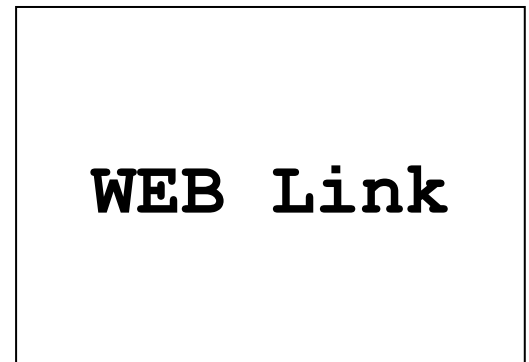

CALIBRATION MENU (INDEX MENU 1)

Use the **MODE** key to scroll through the icons on the status bar, from left to right, select the **Calibration** menu and confirm with the **Enter** key.

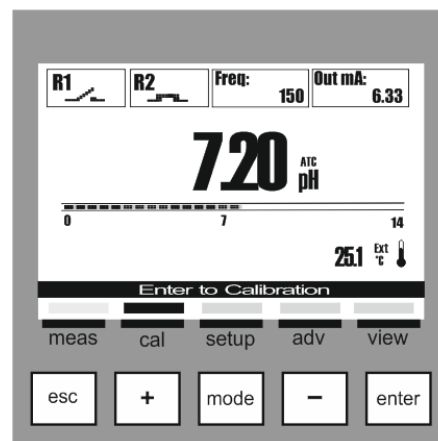

Menu 1 Calibration

The Calibration menu consists of two (2) items or sub-menus:

A: pH or Redox Chemical Measure

B: Temperature

Scroll through the menu using the **(+)** or **(-)** key, select the item and confirm with the **Enter** key.

1 CALIBRATION

- ▶ A: Chemical Measure
- B: Temperature

01/02

Menu 1 Calibration Chemical Measure (Menu 1A)

The Chemical Measure Calibration menu consists of five (5) items or sub-menus:

1A1: Automatic: the instrument requires the standard buffer solutions 7 pH, 4 pH or 9.22 pH.

1A2: Manual: the instrument will suggest the buffer solutions from the default values, but the value can be changed.

1A3: Reference: the instrument accepts the calibration of one point with a manually set value.

1A4: Report: a summary table of calibrated values with indication of the electrode quality.

1A5: Reset (Calibration): the calibrations can be delete and restored the default values.

1A Chem. Measure

- ▶ 1: Automatic
- 2: Manual
- 3: Reference
- 4: Report
- 5: Cal. Reset

01/05

Scroll through the menu using the **(+)** or **(-)** key, select the item and confirm with the **Enter** key.



pH CALIBRATION PROCEDURE

Calibration Menu Chemical Measure (Menu 1A)

Menu 1A1 Automatic pH Calibration

Insert the probe into the 7.00 pH buffer solution.
Press the **Enter** key when ready.

Keep the probe firmly into the buffer solution for the whole period indicated by the instrument

The instrument will display the percentage of quality on the 7.00 pH buffer solution.

Wash the pH probe with clean water and drain it.

Insert the probe into the 4.00 pH or 9.22 pH buffer solution. Press the **Enter** key when ready.

Keep the probe firmly into the buffer solution for the whole period indicated by the instrument

1A	Chem. Measure
▶	1: Automatic 2: Manual 3: Reference 4: Report 5: Cal. Reset
01/05	

1A1	Automatic
Buffer Solution	
7.00pH	0mV
ENTER to start	

1A1	Automatic
WAIT	
7.00pH	0mV
Count Down: 59	

1A1	Automatic
Buffer pH 7.00	100%
Buffer Solution	
4.00/9.22pH	0mV
ENTER to start	

1A1	Automatic
Buffer pH 7.00	100%
WAIT	
4.00/9.22pH	177mV
Count Down: 59	

The instrument will display the percentage of quality on the 7.00 pH and 4.00 or 9.22 pH.

Note:

- 100%: excellent probe quality
- 75%: good probe quality
- 50%: sufficient probe quality
- 25%: poor probe quality; replacement is recommended

Insert the calibration date and press **Enter** to confirm.



Note: The instrument displays "Calibration Failed" in all cases of wrong measure of the buffer solution.

It is recommended to use always a fresh buffer solution and repeat the calibration procedure; if the message persists, replace the pH probe.

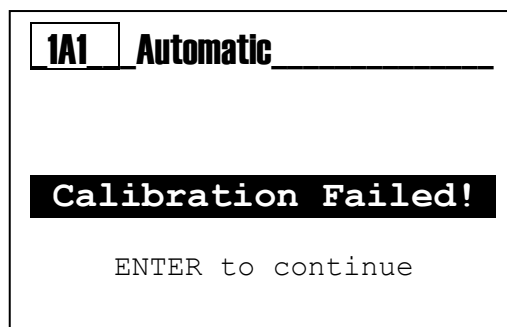
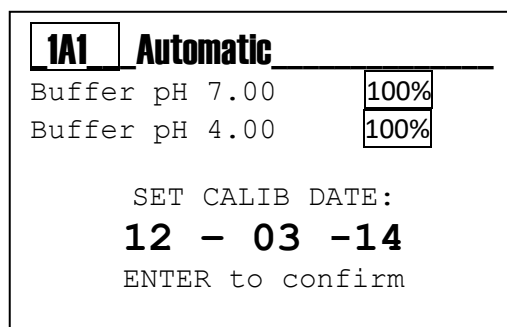
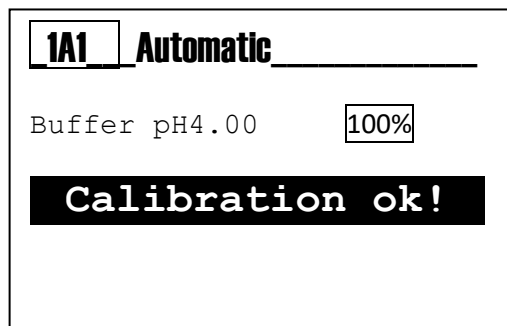

Menu 1A2 Manual pH Calibration

Insert the probe into the 7.00 pH buffer solution and set the value of the buffer solution using the (+) and (-) keys.

Press the **Enter** key when ready.

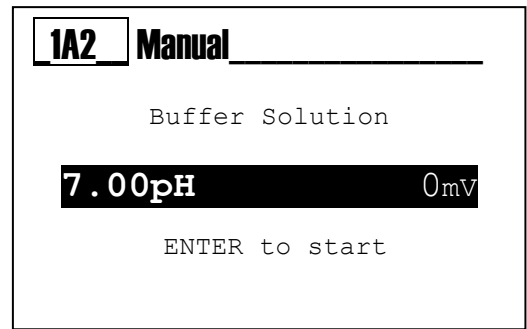

1A2 Manual

Buffer Solution

7.00pH 0mV

ENTER to start

Keep the probe firmly into the buffer solution for the whole period indicated by the instrument

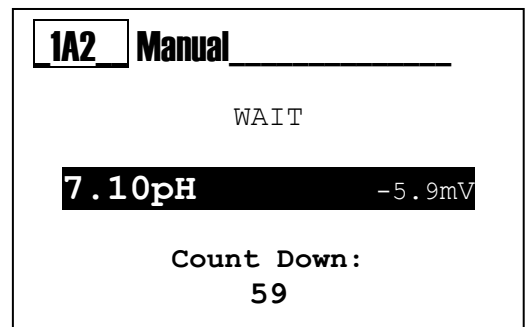

1A2 Manual

WAIT

7.10pH -5.9mV

Count Down:
59

The instrument will display the percentage of quality on the selected pH buffer solution.

Wash the pH probe with clean water and drain it.

Insert the probe into the 4.00 pH buffer solution or select the used value.

Press the **Enter** key when ready.

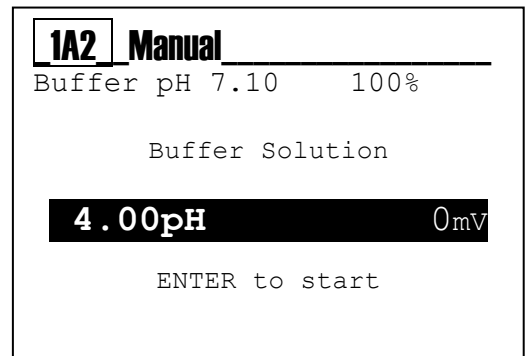

1A2 Manual

Buffer pH 7.10 100%

Buffer Solution

4.00pH 0mV

ENTER to start

Keep the probe firmly into the buffer solution for the whole period indicated by the instrument

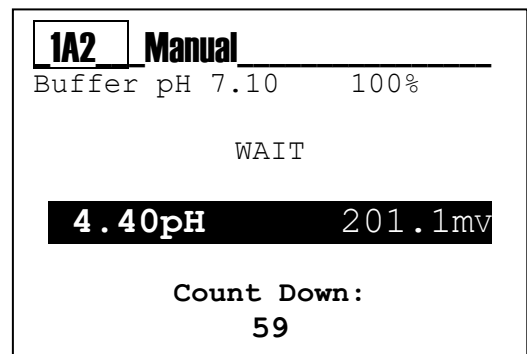

1A2 Manual

Buffer pH 7.10 100%

WAIT

4.40pH 201.1mV

Count Down:
59

The instrument will display the percentage of quality on the buffer solutions used for calibration.

Note:

- 100%: excellent probe quality
- 75%: good probe quality
- 50%: sufficient probe quality
- 25%: poor probe quality; replacement is recommended

Insert the calibration date and press **Enter** to confirm.



Note: The instrument displays "Calibration Failed" in all cases of wrong measure of the buffer solution.

It is recommended to use always a fresh buffer solution and repeat the calibration procedure; if the message persists, replace the pH probe. Keep the probe firmly into the buffer solution for the whole period indicated by the instrument.

1A2	Manual	_____
Buffer pH7.10		100%
Buffer pH4.40		100%
Calibration ok!		

1A2	Manual	_____
Buffer pH7.10		100%
Buffer pH4.40		100%
SET CALIB DATE: 12 - 03 -14 ENTER to confirm		

1A2	Manual	_____
Calibration Failed!		
ENTER to continue		

Menu 1A3 External Reference

Calibration of the pH measure with an external reference value, manually set.
The instrument performs a correction of the value by adding an offset value to the real measure.

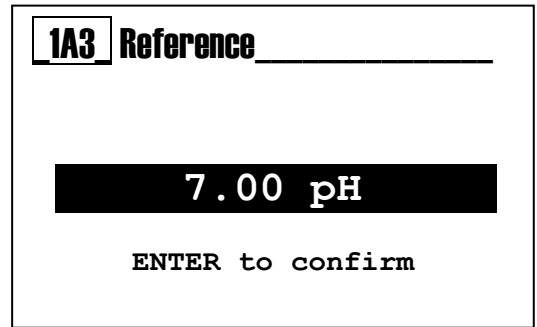

Menu 1A4 Report

Displaying of all the parameters calculated during calibration and the manually set calibration date.

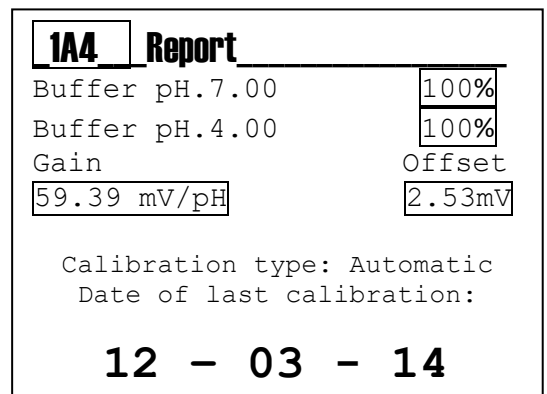

Menu 1A5 Reset Calibration

This function allows the user to delete all the calibrations and to restore the default values.

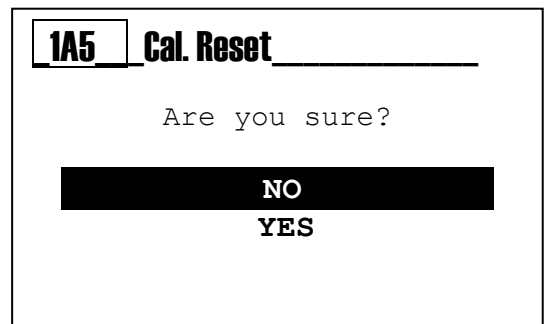



ORP CALIBRATION PROCEDURE

Calibration Menu Chemical Measure (Menu 1A)

Menu 1A1 Automatic ORP Calibration

Menu 1A1 Automatic ORP Calibration

Insert the probe into the 465 mV buffer solution.
Press the **Enter** key when ready.

Keep the probe firmly into the buffer solution for the whole period indicated by the instrument

The instrument will display the percentage of quality on the 465 mV buffer solution.

Note:

- 100%: excellent probe quality
- 75%: good probe quality
- 50%: sufficient probe quality
- 25%: poor probe quality; replacement is recommended

Insert the calibration date and press **Enter** to confirm.

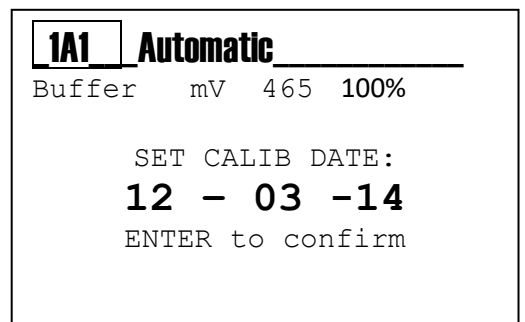
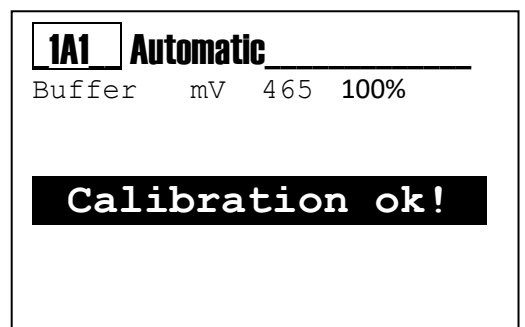
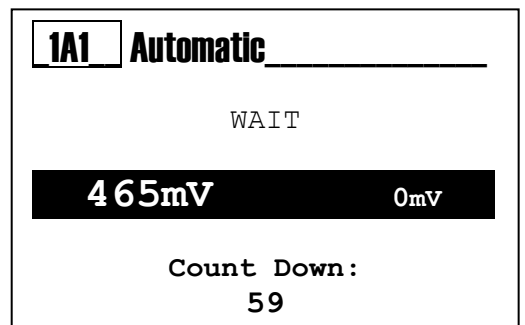
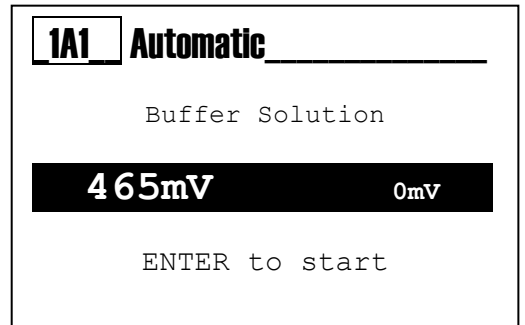
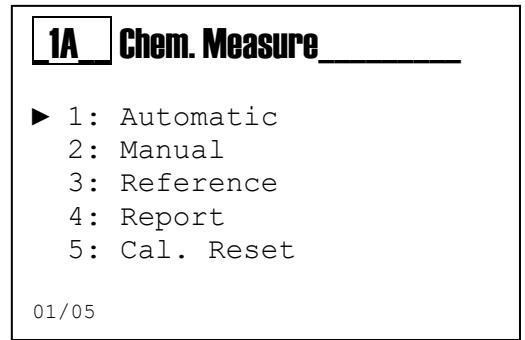



Note: The instrument displays "Calibration Failed" in all cases of wrong measure of the buffer solution.

It is recommended to use always a fresh buffer solution and repeat the calibration procedure; if the message persists, replace the ORP probe.

Menu 1A2 Manual

Insert the probe into the 475 mV buffer solution and set the value of the buffer solution using the (+) and (-) keys.
Press the **Enter** key when ready.

Keep the probe firmly into the buffer solution for the whole period indicated by the instrument

The instrument will display the percentage of quality on the 475 mV buffer solution.

Note:

- 100%: excellent probe quality
- 75%: good probe quality
- 50%: sufficient probe quality
- 25%: poor probe quality; replacement is recommended

Insert the calibration date and press **Enter** to confirm.

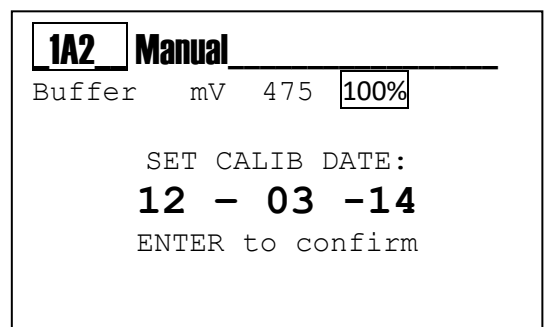
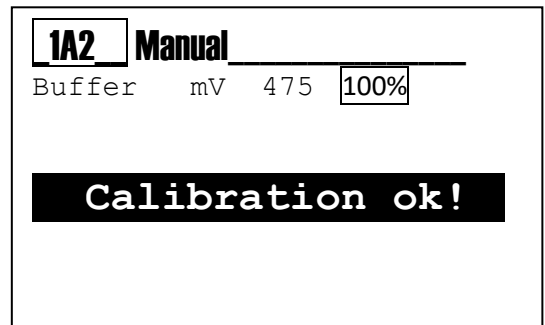
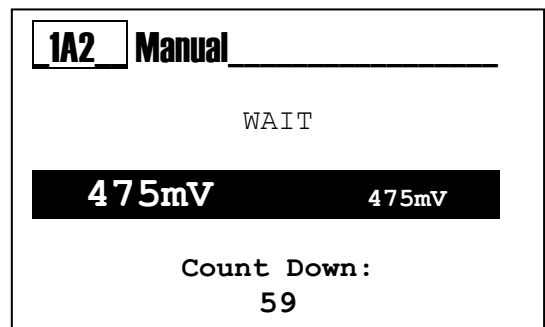
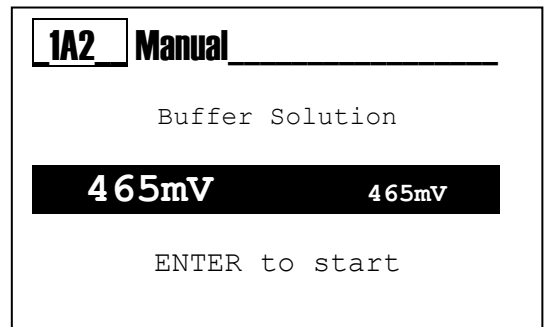
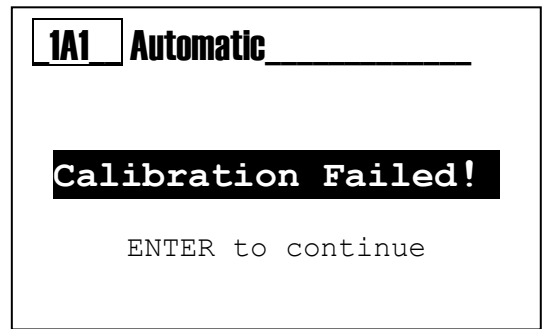



Note: The instrument displays "Calibration Failed" in all cases of wrong measure of the buffer solution.

It is recommended to use always a fresh buffer solution and repeat the calibration procedure; if the message persists, replace the ORP probe.

Menu 1A3 External Reference

Calibration of the ORP measure with an external reference value, manually set.

The instrument performs a correction of the value by adding an offset value to the real measure.

Menu 1A4 Report

Displaying of all the parameters calculated during calibration and the manually set calibration date.

Menu 1A5 Reset Calibration

This function allows the user to delete all the calibrations and to restore the default values.

1A2 Manual_____

Calibraion Failed!

ENTER to continue

1A3 Reference_____

465mV

ENTER to confirm

1A4 Report_____

Buffer mV465

Gain Offset

Type of Calibration: Manual
Last calibration date:

12 - 03 - 14

1A5 Reset Calibration_____

Are you sure?

NO

YES

Temperature Measure Calibration Menu (Menu 1B)

Menu 1B

Calibration of the Temperature Measure with an external reference value, manually set. The instrument performs a correction of the value by adding an offset value to the real measure.

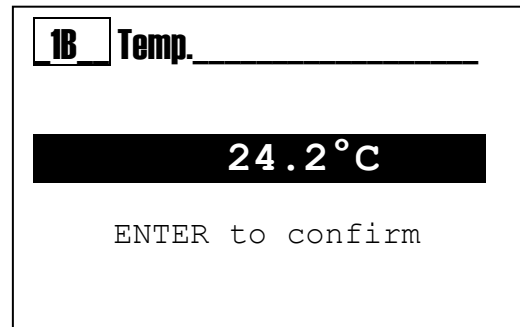

1B Temp. _____

24.2°C

ENTER to confirm

Menu 1B

The instrument displays the message "Calibration Failed" if the probe is damaged or disabled from the menu 3E1; see manual, the Advanced Menu section.

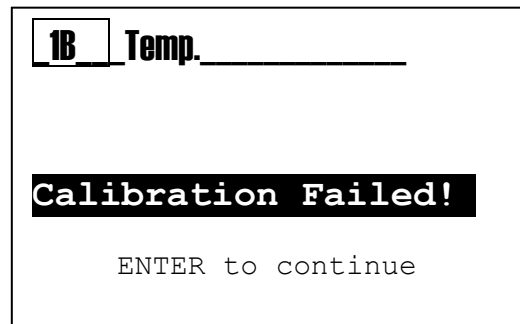

1B Temp. _____

Calibration Failed!

ENTER to continue

SETUP MENU (INDEX MENU 2)

Use the **MODE** key to scroll through the icons on the status bar, from left to right, select the **setup** menu and confirm with the **Enter** key.

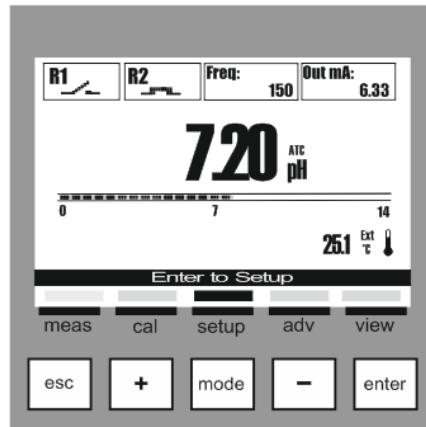

The Setup menu consists of four (4) items or sub-menus:

- 2A: Relay 1
- 2B: Relay 2
- 2C: SSR1 (Solid State Relay)
- 2D: Output mA1 (Range 4÷20 mA)



Note: To set the relative function to each output, read the manual at the **Advanced Menu\Outputs Configuration** section (INDEX MENU 3G).

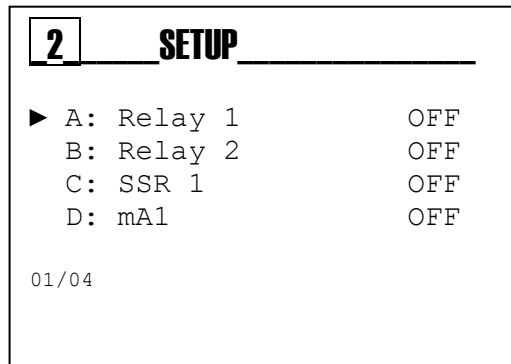

Below are illustrated the settings required for each sub-menu indicated above.

To exit the menu, press the **Esc** key; when at least one parameter has been changed, the instrument will display the question “save?”; confirm with the **Enter** key.

For not saving, select NO using the **(+)** or **(-)** key and confirm with the **Enter** key.

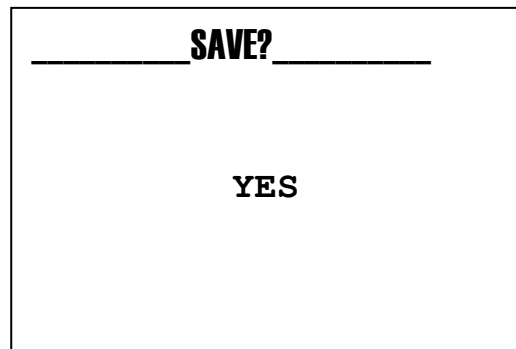

SETUP MENU \ RELAY 1 (ONE) (INDEX MENU 2A)

Scroll through the menu using the **(+)** or **(-)** key, select the item Relay 1 and confirm with the **Enter** key.

Scroll through the menu using the **(+)** or **(-)** key, select the item and confirm with the **Enter** key.

The **Relay 1** can be set for Chemical Measure, the **Relay 2** can be set either for Chemical or for Temperature Measure with the following activation methods:

ON/OFF Method

(Activation on threshold, with maintenance of the state)

2A1 **SetPoint**: Chemical value to maintain into the process

2A2 **Activation Type**: **Low/Alka** as the minimum value to maintain **High/Acid** as the maximum value to maintain

2A3 **Hysteresis**: Incremental or decremental value of the SetPoint

2A4 **Hysteresis Time(*)**: Time activated on the hysteresis value

2A5 **Delay Start**: Delay time for relay activation

2A6 **Delay End**: Delay time for relay deactivation

2A7 **OFA**: Relay maximum activation time

2A8 **Over Range**: A value that is subtracted from and added to the SetPoint value and defines a measuring range of operation, outside of which the measure error message is displayed.



Note: See **ANNEX A** for a graphical example on using

Timed Method

(Timed activation on threshold)

We have all the items described in the ON/OFF method.

In addition we have:

2A9 **Time On**: Relay closing time

2A10 **Time Off**: Wait time with the relay open



Note: See **ANNEX B** for a graphical example on using

Proportional (PWM) Method

(Timed activation on proportional threshold)

We have all the items described in the ON/OFF method.

In addition we have:

2A9 **Interval**: Maximum time to modulate according to the measure

2A10 **Proportional Band**: A value that is subtracted from or added to the SetPoint value, within the range the instrument calculates the relay closing time proportional to the chemical measure according to the distance from the SetPoint.



Note: See **ANNEX C** for a graphical example on using

(*The hysteresis time has no effect if the hysteresis value is not set on menu 2A3)

2 SETUP	
▶ A: Relay 1	OFF
B: Relay 2	OFF
C: SSR 1	OFF
D: mA1	OFF
01/04	

2A RELAY_1_ON/OFF	
▶ 1: SetPoint	7.20 pH
2: Type	Acid
3: Hysteresis	0.00 pH
4: Hyst. Time	00' 00"
5: Delay Start	00' 00"
6: Delay End	00' 00"
7: OFA	OFF
8: Over Range	OFF
01/08	

2A RELAY_1_Timed	
7: OFA	OFF
8: Over Range	OFF
▶ 9: Time On	00' 10"
10: Time Off	00' 10"
09/10	

2A RELAY_1_PWM	
7: OFA	OFF
8: Over Range	OFF
9: Interval	00' 10"
▶ 10: Prop. Band	0.20pH
10/10	

SETUP MENU \ RELAY 2 (TWO) (INDEX MENU 2B)

Scroll through the menu using the **(+)** or **(-)** key, select the item Relay 2 and confirm with the **Enter** key.

Scroll through the menu using the **(+)** or **(-)** key, select the item and confirm with the **Enter** key.

Relay 2 (two) can be set for the Chemical Measure or Temperature as indicated in the relay 1 menu (see the previous page), it is also possible to set the Wash or Alarm mode as follows:

Wash Method

Activation of a washing system for the probe

2B1 **Wash Time**: Value in minutes and seconds for washing the probe.

2B2 **Delay Measure**: Value in minutes and seconds to wait for the stability of measure.

2B3 **Wait New Wash**: Value in hours and minutes of waiting for a new washing action.



Note: See **ANNEX D** for a graphical example on using

Alarm Method

Remote repetition of the alarm through relay 2 (two). below is the list of the alarm events:

2B1 **Over Range R1**: chemical measure out of range Relay 1

2B2 **OFA R1**: Maximum dosing time expired

2B3 **Reed Alarm**: Alarm for the Reed sensor activation

2B4 **Temperature Probe Alarm**: Alarm for probe disconnected



Note: See **ANNEX E** for a graphical example on using

2 SETUP	
A: Relay 1	OFF
▶ B: Relay 2	OFF
C: SSR 1	OFF
D: mA1	OFF
02/04	

2B Relay 2	
▶ 1: Time	00' 00"
2: Delay	00' 00"
3: Wait	OFF
01/03	

2B Relay 2	
▶ 1: R1 OverRng	NO
2: R1 OFA	NO
3: Reed Alarm	NO
4: Temp. Alarm	NO
01/04	

SETUP MENU \ SSR1 OUTPUT (INDEX MENU 2C)

Scroll through the menu using the **(+)** or **(-)** key, select the item SSR1 and confirm with the **Enter** key.

Scroll through the menu using the **(+)** or **(-)** key, select the item and confirm with the **Enter** key.

The output SSR1 (one) is a solid state relay used as frequency output.

The **output SSR1** can be set either for Chemical Measure or for Temperature Measure

SSR1 Setup (INDEX MENU 2C)

2C1 **SetPoint**: Chemical value to maintain into the process

2C2 **Activation Type**:

Low/Alka as the minimum value to maintain

High/Acid as the maximum value to maintain

2C3 **Pulse Max**: Maximum value of pulses (range:20÷400)

2C4 **Pulse Min**: Minimum value of pulses (range:1÷100)

2C5 **Proportional Band**: A value that is subtracted from or added to the SetPoint value, within the range the instrument calculates the number of pulses proportional to the measure according to the distance from the SetPoint.

2 SETUP	
A: Relay 1	OFF
B: Relay 2	OFF
▶ C: SSR 1	OFF
D: mA1	OFF
03/04	

2C SSR1	
▶ 1: SetPoint	7.40pH
2: Type	Acid
3: Pulse Max	400
4: Pulse Min	1
5: Prop. Band	0.20pH
01/05	



Note: See **ANNEX F** for a graphical example on using

(* If the Pulse min value is greater than Pulse Max value, the output will have the Pulses min value)

SETUP MENU \ MA1 OUTPUT (INDEX MENU 2D)

Scroll through the menu using the **(+)** or **(-)** key, select the item **mA1** and confirm with the **Enter key**.

Scroll through the menu using the **(+)** or **(-)** key, select the item and confirm with the **Enter key**

The output mA1 (one) is a current output in mA (milliAmpere), in active configuration with the range 4÷20 mA.

The **Output mA1** can be set either for Chemical Measure or for Temperature Measure.

Output mA1 Setup (INDEX MENU 2D)

2D1 **Start mA**: Measure value associated to the 4 mA value

2D2 **End mA**: Measure value associated to the 20 mA value

2D3 **Hold**: Freezes the current value in case of Holding Alarm

2D4 **Namur**: Sets the current value to 3.6 mA or 22 mA in case of Alarm



Note: See **ANNEX G** for a graphical example on using

2 SETUP	
A: Relay 1	OFF
B: Relay 2	OFF
C: SSR 1	OFF
▶ D: mA1	OFF

04/04

2D Output_mA1	
▶ 1: Start mA	0.00pH
2: End mA	14.00pH
3: Keep	NO
4: Namur	OFF

01/04

ADVANCED MENU (MENU INDEX 3)

Use the **MODE** key to scroll through the icons on the status bar, from left to right, select the **adv** menu and confirm with the **Enter** key.

The **Advanced** menu consists of thirteen (12) items or sub-menus, as follows:

- A: **Language**
- B: **Password**
- C: **Display**
- D: **Chemical Measure**
- E: **Temperature Measure**
- F: **Alarms Configuration**
- G: **Outputs Configuration**
- H: **Control Panel**
- I: **Statistics**
- L: **System Reset**
- M: **Firmware Revision**

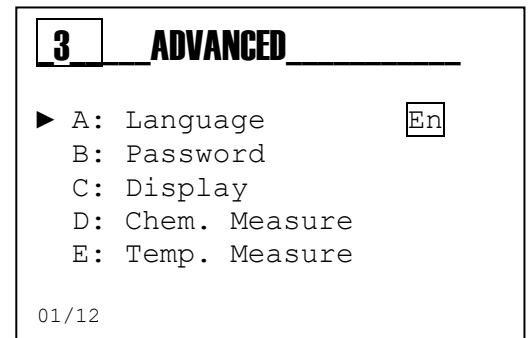
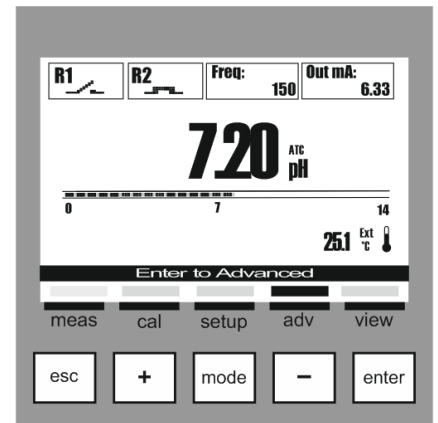

Below are illustrated the settings required for each sub-menu indicated above.

To exit the menu, press the **Esc** key; when the parameters have been changed, the instrument will display the question "save?"; confirm with the **Enter** key.



For not saving, select NO using the (+) or (-) key and confirm with the **Enter** key.

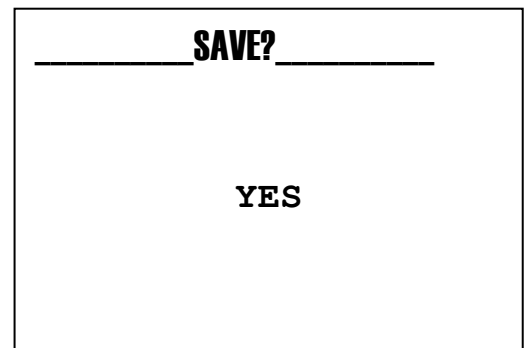

ADVANCED MENU \ LANGUAGE (INDEX MENU 3A)

The menu consists of five (5) items that allow to select the dialog language for the instrument's menus and messages.

Scroll through the menu using the **(+)** or **(-)** key, select the item Language and confirm with the **Enter** key.

Scroll through the menu using the **(+)** or **(-)** key, select the item and confirm with the **Enter** key.

The instrument automatically changes the language of the menu and returns to the previous level, menu 3.

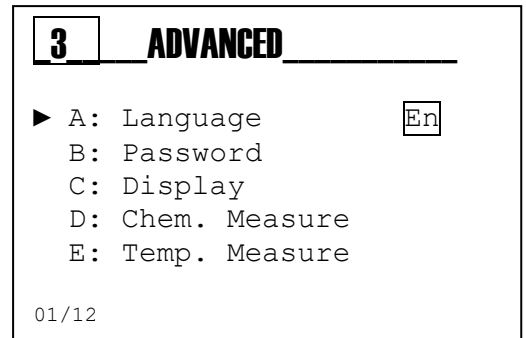

ADVANCED MENU \ PASSWORD (INDEX MENU 3B)

The menu consists of three (3) items that allow to select the menu protection Password and enable the Calibration menu or the Setup menu.

Scroll through the menu using the **(+)** or **(-)** key, select the item and confirm with the **Enter** key.

Password function

3B1 **Set Password**: set the numeric value

Note: If the password is present will be displayed

Example: "Old Password 1234"

3B2 **Calibration Menu**: Enable or Disable the Calibration menu

3B3 **Setup Menu**: Enable or Disable the Setup menu



Note: To remove the password set four zeros (0000) and confirm with the **Enter** key.

The following are examples of the sub-menus shown above.



Menu 3B1

Set the value for password, other than 0000

Scroll through the menu using the **(+)** or **(-)** key, select the next item with **Mode** key.

Menu 3B2

YES = Menu Enabled

NO = Menu Disabled; can be accessed by entering the password

Menu 3B3

YES = Menu Enabled

NO = Menu Disabled; can be accessed by entering the password

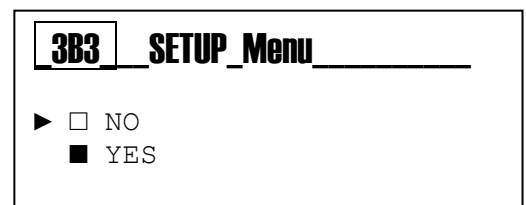
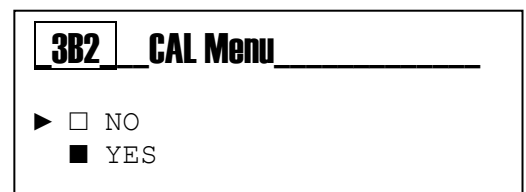
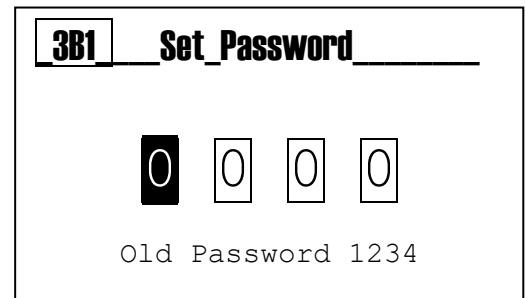
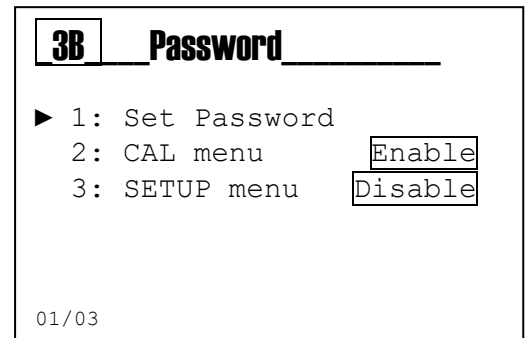
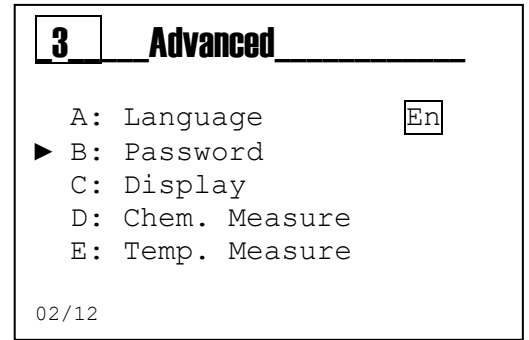

ADVANCED MENU \ DISPLAY (INDEX MENU 3C)

The menu consists of five (5) items that allow to select Contrast, Mode, On, ECO, Reverse.

Scroll through the menu using the **(+)** or **(-)** key, select the item and confirm with the **Enter** key.

Display Function:

3C1 **Contrast:** Balance value between the menu writings and the background brightness

3C2 **Mode:** Turned on, Turned off, "ECO" Adjustment

3C3 **On:** Light value function always on

3C4 **ECO:** Light value function of electronic regulation

3C5 **Negative Display (Reverse):** Inverted display, white on writings black background.

The following are examples of the sub-menus shown above.

Menu 3C1

Adjusts the background brightness

Menu 3C2

Select the Backlight function:

OFF= Turned off; ON= Turned on; ECO= Fade

Menu 3C3

Select the brightness value for ON mode

Menu 3C4

Select the brightness value for ECO mode, after one minute the brightness decreases to the set value.

Menu 3C5

Invert the writings on the display to obtain a high contrast

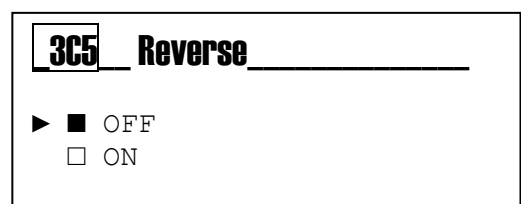
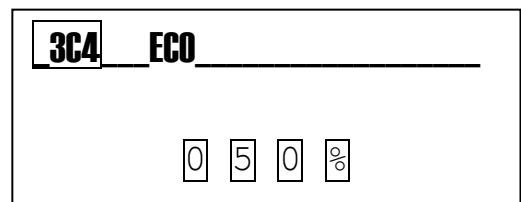
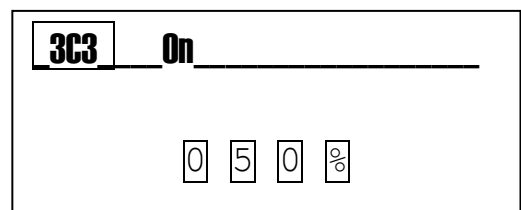
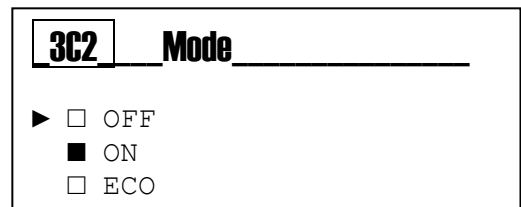
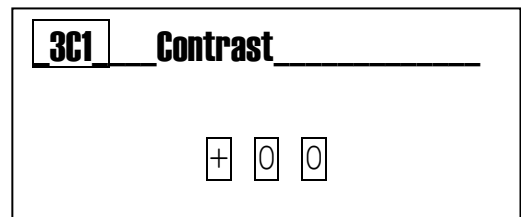
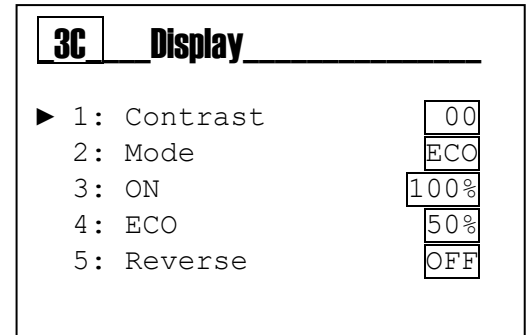
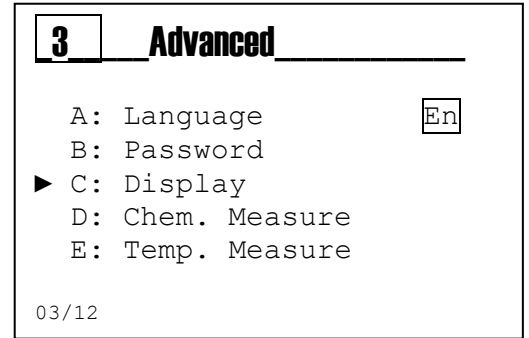

ADVANCED MENU \ CHEMICAL MEASURE (INDEX MENU 3D)

The menu consists of four (4) items that allow to select Measure Unit, Temperature Compensation and Measure Filter.

Scroll through the menu using the **(+)** or **(-)** key, select the item and confirm with the **Enter** key.

Chemical Measure Function (INDEX MENU 3D)

3D1 **Measure Unit:** Select the chemical measure, pH or mV

3D2 **Temperature Compensation:** The measure is compensated for temperature::

- **MTC**= Manual, with a fixed value manually set.
- **ATC**= Automatic, with temperature sensor

Note: To set the value manually, access the menu 3E2 Temp. Meas.

3D3 **Measure Filter:** The measure is filtered with arithmetic mean.

- **Low**= arithmetic mean every 4 seconds
- **Medium**= arithmetic mean every 8 seconds
- **High**= arithmetic mean every 16 seconds



3	Advanced	<input type="text"/>
A:	Language	<input type="text"/>
B:	Password	<input type="text"/>
C:	Display	<input type="text"/>
▶ D:	Chem. Measure	<input type="text"/>
E:	Temp. Measure	<input type="text"/>
04/12		

3D	Chem. Measure	<input type="text"/>
▶ 1:	Unit Measure	<input type="text"/>
2:	Temp. Comp.	<input type="text"/>
3:	Filter	<input type="text"/>
01/03		

The following are examples of the sub-menus shown above.

Menu 3D1

Select the measure pH or mV (ORP).

Note: The change of measure unit provides a parameter reset with the default values.

3D1	Unit Meas.	<input type="text"/>
▶ <input checked="" type="checkbox"/>	pH	<input type="text"/>
<input type="checkbox"/>	mV	<input type="text"/>
01/02		

Menu 3D2

Select the temperature compensation mode for the Chemical measure.

Note: For ORP measures has no effect.

3D2	Temp. Comp	<input type="text"/>
▶ <input checked="" type="checkbox"/>	MTC	<input type="text"/>
<input type="checkbox"/>	ATC	<input type="text"/>
01/02		

Menu 3D3

The measure is filtered with arithmetic mean.

- **Low**= arithmetic mean every 4 seconds
- **Medium**= arithmetic mean every 8 seconds
- **High**= arithmetic mean every 16 seconds

3D3	Filter	<input type="text"/>
▶ <input checked="" type="checkbox"/>	Low	<input type="text"/>
<input type="checkbox"/>	Medium	<input type="text"/>
<input type="checkbox"/>	High	<input type="text"/>
01/03		

ADVANCED MENU \ TEMPERATURE MEASURE (INDEX MENU 3E)

Scroll through the menu using the **(+)** or **(-)** key, select the item and confirm with the **Enter** key.

Temperature Measure Function (INDEX MENU 3E)

3E1 Select: PT100 or PT1000 temperature sensor connected or using a manual temperature value.

3E2 Measure Unit: Set Celsius (°C) or Fahrenheit (°F) unit

3E3 Manual Value: Set the temperature value without PT100 or PT1000 temperature sensor

3E4 Filter: The measure is filtered with arithmetic mean.

- **Low**= arithmetic mean every 4 seconds
- **Medium**= arithmetic mean every 8 seconds
- **High**= arithmetic mean every 16 seconds

The following are examples of the sub-menus shown above.

Menu 3E1

Select between manual temperature value function and external temperature measure through PT100 or PT1000 temperature sensor.

Menu 3E2

Select the measure unit.

Menu 3E3

Set the temperature value as manual value.

Menu 3E4

The measure is filtered with arithmetic mean.

- **Low**= arithmetic mean every 4 seconds
- **Medium**= arithmetic mean every 8 seconds
- **High**= arithmetic mean every 16 seconds

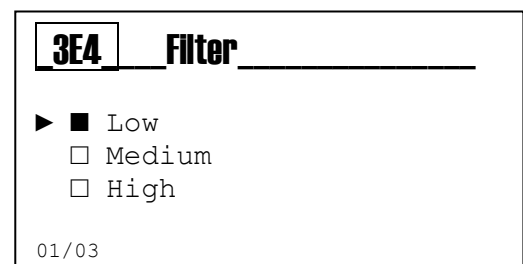
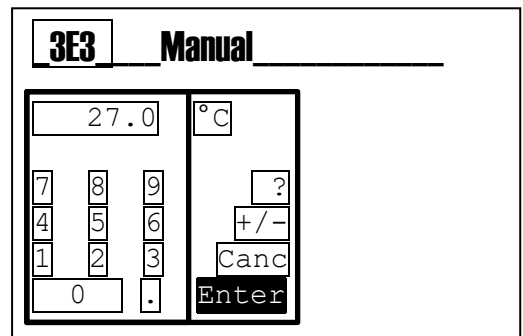
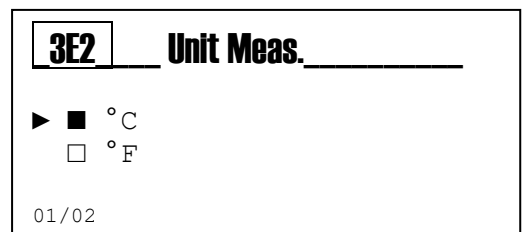
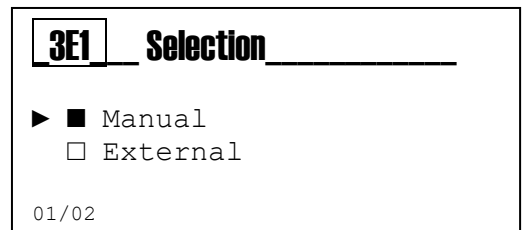
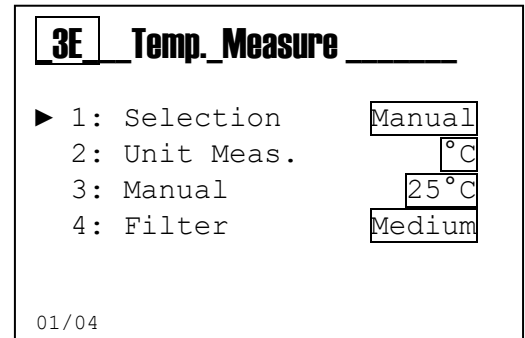
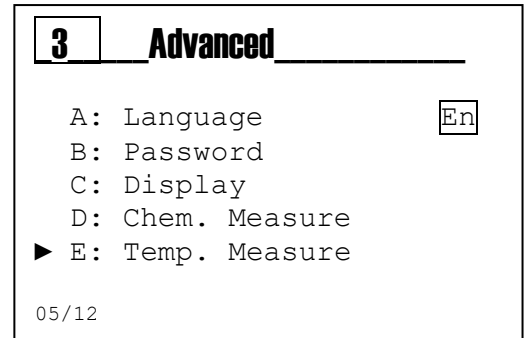

ADVANCED MENU \ ALARMS CONFIGURATION (INDEX MENU 3F)

Scroll through the menu using the **(+)** or **(-)** key, select the item and confirm with the **Enter** key.

Alarms Configuration Function

3F1 Reed Logic: Set the sensor logic

- Reed NO (Normally Open)
- Reed NC (Normally Close)

3F2 Reed Delay: Set the delay time for alarm activation to change REED status

3F3 Instrument blocking: Enables instrument blocking in case of alarm. The outputs are automatically set on the programmed alarm state.

3F4 Temp. Probe Alarm: Enables a visual or remote alarm in case the temperature probe is broken or disconnected

3	Advanced
B: Password	
C: Display	
D: Chem. Measure	
E: Temp. Measure	
▶ F: Alarms Setting	
06/12	

3F	Alarm_Setting
▶ 1: Reed Logic	<input type="text" value="NO"/>
2: Reed Delay	<input type="text" value="00'00"/>
3: Block	<input type="text" value="No"/>
4: Alarm Temp.	<input type="text" value="Notify"/>
01/04	

ADVANCED MENU \ OUTPUTS CONFIGURATION (INDEX MENU 3G)

Scroll through the menu using the (+) or (-) key, select the item and confirm with the **Enter** key.

Outputs Configuration Function

3G1 Relay 1: Disabled (Off), On/OFF (threshold), Timed, Proportional PWM, for Chemical Measure

3G2 Relay 2: Disabled (Off), On/OFF (threshold), Timed, Proportional PWM, either for Chemical Measure or for Temperature Measure, and also Probe Wash, Remote Alarm

3G3 SSR 1: Disabled (Off), Chemical Measure, Temperature Measure

3G4 mA 1: Disabled (Off), Chemical Measure, Temperature Measure



Note: On the Setup menu (INDEX MENU 2) it is possible to set the parameters for each selected function.

3 Advanced

C: Display
 D: Chem. Measure
 E: Temp. Measure
 F: Alarm Setting
 ▶ G: Output Setting

07/12

3G Output Setting

▶ 1: Relay 1 OFF
 2: Relay 2 OFF
 3: SSR 1 OFF
 4: mA 1 OFF

01/04

3G1 Relay 1

▶ OFF
 On/OFF Measure
 Timed Measure
 PWM Measure

01/04

3G2 Relay 2

▶ OFF
 On/OFF Measure
 Timed Measure
 PWM Measure
 On/OFF Temp.
 Timed Temp.
 PWM Temp.
 Probe Wash
 Alarm

01/09

3G3 SSR 1

▶ OFF
 Measure
 Temperature

01/03

3G4 mA 1

▶ OFF
 Measure
 Temperature

01/03

ADVANCED MENU \ CONTROL PANEL (INDEX MENU 3H)

Menu 3H Control Panel

Scroll through the menu using the **(+)** or **(-)** key, select the item and confirm with the **Enter** key.

- 3H1 Chemical Measure:** Displays the unfiltered measure in mV.
- 3H2 Temp. Measure:** Displays the unfiltered measure in °C/°F
- 3H3 Simulation Relay 1:** Manual closing of the relay contact
- 3H4 Simulation Relay 2:** Manual closing of the relay contact
- 3H5 Simulation Frequency 1:** Simulates an output value
- 3H6 Simulation Current Output 1:** Simulates an output value
- 3H7** Displays the **Reed Input** status



Note: The instrument allows the simultaneously simulation of multiple outputs, all the set values will be cleared on exiting the menu **3H Control Panel**.

3
Advanced

- E: Temperature Measure
- F: Alarm Setting
- G: Output Setting
- ▶ H: Control Panel

08/11

3H
Control_Panel

- ▶ 1: Chem. Measure
- 2: Temp. Measure
- 3: Relay 1 Sim.
- 4: Relay 2 Sim.
- 5: Freq. 1 Sim.
- 6: Out mA 1 Sim.
- 7: Reed Input

01/07

ADVANCED MENU \ STATISTICS (INDEX MENU 3I)

Menu 3I Statistics

Scroll through the menu using the **(+)** or **(-)** key, select the item and confirm with the **Enter** key.

- 3I1** Number of registered Startups
- 3I2** Number of registered Alarms
- 3I3** Number of activations Relay 1
- 3I4** Number of activations Relay 2
- 3I5** Number of activations Reed
- 3I6** Reset all values recorded in the statistics menu

3
Advanced

- F: Alarm Setting
- G: Output Setting
- H: Control Panel
- ▶ I: Statistics

09/11

3I
Statistics

- ▶ 1: Power On 0
- 2: Alarms 0
- 3: RL 1 Act. 0
- 4: RL 2 Act. 0
- 5: Reed Act. 0
- 6: Statistics Reset

01/06

ADVANCED MENU \ RESET INSTRUMENT (INDEX MENU 3L)



Menu 3L System Reset

The instrument allows to delete all the parameters and restore the default values.

3 Advanced

- G: Output Setting
- H: Control Panel
- I: Statistics
- ▶ L: System Reset

10/11

3L System Reset

Are You Sure?

NO
YES

ADVANCED MENU \ FIRMWARE REVISION (INDEX MENU 3M)

Menu 3M Firmware Revision

The instrument displays the Firmware code and revision of the device.

3 Advanced

- H: Control Panel
- I: Statistics
- L: System Reset
- ▶ M: Firmware Revision

11/11

3M Fw_Revision

Firmware Code
0000529XXX

Fw Revision
X.X

VIEW MENU (INDEX MENU 4)

Use the **MODE** key to scroll through the icons on the status bar, from left to right, select the **view** menu and confirm with the **Enter** key.

The **Preview Menu** consists of 3 views

Scroll through the menu using the **(+)** or **(-)** key, select the item and confirm with the **Enter** key.

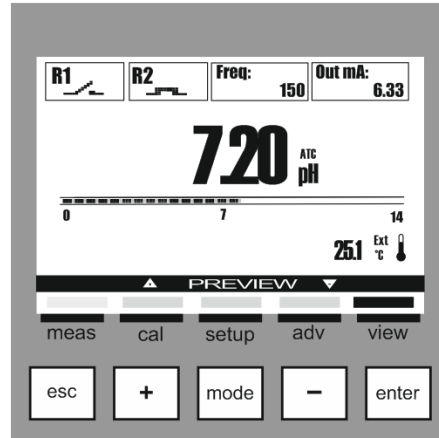
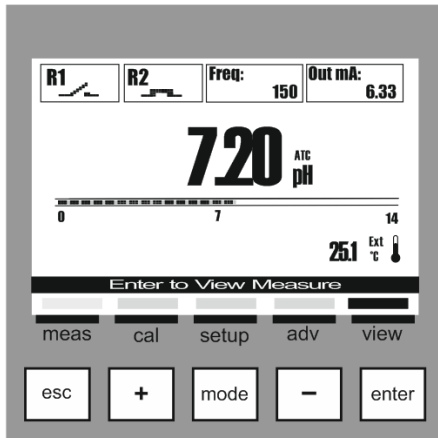

Views Table

<p>Preview 1/3 Complete</p>	<p>Preview 2/3 Two Big Measures</p>	<p>Preview 3/3 One Big Measure</p>

GENERAL SPECIFICATIONS

pH/ORP Specifications	
Range pH	0.00 to 14.00 pH
Range mV	-2000 to 2000 mV
Resolution pH	0.01
Accuracy pH	± 0.10 pH
Resolution mV	1 mV
Accuracy mV	± 5 mV
Input Impedance	> 10 ¹²
Pt100/ Pt1000 Specifications	
Temperature Input	Pt100/Pt1000
Pt100/Pt1000 Detection	Automatic
Error Condition	Automatic detection of disconnected/damaged probe
Driving Current	1 mA
Temperature Measure Range	0.0 to 100.0 °C (32.0 to 212.0 °F)
Sensor Maximum Distance	10 to 20 m (33 to 65 ft) depending on sensor
Temperature Resolution	0.1°C (°F)
Temperature Accuracy **	± 1.0°C (± 1.8 °F)

MECHANICAL SPECIFICATIONS FOR VERSION 1/4DIN

Dimensions (chassis – A x L x P)*	92 x 92 x 57,3 mm
Front Bezel – (A x L)	96 x 96 mm
Max. Depth	42 mm
Weight	310 g (0,68 lb)
Material	ABS/polycarbonate
Protection	IP 65 (front)/IP 20 (chassis)
Relative Humidity	0 to 95% non-condensing

* L = Width, A = Height, P = Depth

MECHANICAL SPECIFICATIONS FOR VERSION 1/2DIN

Dimensions (chassis – A x L x P)*	144 x 144 x 122.5 mm
Front Bezel – (A x L)	144 x 144 mm
Weight	735 g (1.62 lb)
Material	ABS/polycarbonate
Protection	IP 65
Relative Humidity	0 to 100% condensing

** L = Width, A = Height, P = Depth

ENVIRONMENTAL SPECIFICATIONS FOR VERSION 1/2DIN & 1/4DIN

Storage Temperature	- 25 to 65 °C (- 13 to 149 °F)
Environmental temperature range of operation	-10 to 50 °C (14 to 122 °F)
Emissions	According to EN55011 Class A specifications

ELECTRICAL SPECIFICATIONS

Power Supply	
Electrical Requirements	24, 115 or 230 VAC, 2.5VA
Frequency	50 or 60 Hz
Power Supply Fuse	500 mA delay not recoverable
Relay Outputs	
RL1 and RL2	2-SPST mechanical 250 VAC/5A, 30 VCC/3 A
Relay RL1 Configuration	Load Activation
Relay RL2 Configuration	Load Activation, Probe Wash, Alarm Repetition
Cycle time	1sec to 3600sec
Delay time	1sec to 3600sec
Test Mode	ON, OFF
SSR Outputs (Solid State Relays)	
SSR1	2-SPST 60 VAC, max 100 mA, Bidirectional, NPN, PNP
Resistance in ON State	3 ohms @ 100mA
Leakage Current in OFF State	4 nA max
SSR1 Configuration	Pulse output
Frequency Range	0 to 400 pulse/min
Pulse Duration	100 msec
Test Mode	0 to 400 pulse/min
Outputs 4÷20 mA	
Analog Output Signals	1 output 4÷20 mA, galvanically isolated from the power supply.
Measure Error	+/- 0,05 mA
Load	max. 500 Ω
Error Condition	NAMUR: OFF, 3.6 mA, 22 mA
Test Mode	3 to 23 mA
Digital Inputs	
REED Digital Input	Input for dry contact 5 VCC, max 6 mA
User Interface	
Connection Terminals	Removable screw terminals AWG 14 < 2.5 mm ²
Machine Cycle Time	ca. 1 s
Keyboard	5 tactile feedback keys
Display	Graphic LCD 128x128 pixels, Transflective, Backlit
Display Refresh	500 msec
Backlight	White, with energy saving function

ANNEX A: ON/OFF RELAY SETUP

Below is an example of settings for the Relay 1 or 2 to adjust the pH by dosing acid chemical product using the pulse/pause method (on/off).

Example:

2A RELAY_1_ON/OFF	
1: SetPoint	7.20 pH
2: Type	Acid
3: Hysteresis	0.00 pH
4: Hyst. Time	00'00"
5: Delay Start	00'00"
6: Delay End	00'00"
7: OFA	OFF
8: Over Range	3 pH

01/08

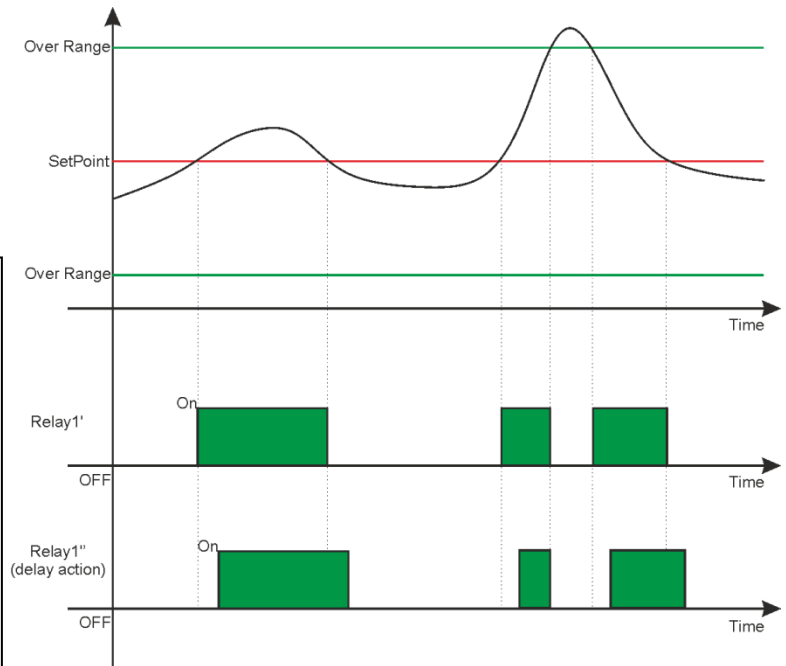

Note:



- **Relay Activation:** When the measure (black line) exceeds the SetPoint the relay is activated and this status is maintained until the measure decreases at the SetPoint value (see relay 1').
- **Delay Activation:** By setting the menu items "5" and "6" the relay activation will be delayed equal to the set time (see relay 1'').
- **Chemical Measure out of range:** When the measure (black line) exceeds the maximum or minimum Over Range value (green line), the system displays a visual alarm and blocks the dosage by changing the status of the relay 1 or 2.

ALKA Function: By setting the menu item "2" with the variable ALKA (Alkaline) the relays activations are inverted compared to the above diagram.

Hysteresis Function: By setting the menu items "3" and "4" the instrument maintains the relay activation status both for the chemical measure value and for the time.

ANNEX A: ON/OFF RELAY SETUP WITH OFA FUNCTION.

Below is an example of settings for the Relay 1 or 2 to adjust the pH by dosing acid chemical product using the pulse/pause method (on/off) with OFA timers.

2A RELAY_1_ON/OFF	
1: SetPoint	7.20 pH
2: Type	Acid
3: Hysteresis	0.00 pH
4: Hyst. Time	00'00"
5: Delay Start	00'00"
6: Delay End	00'00"
7: OFA	00h 10m
8: Over Range	3 pH

01/08

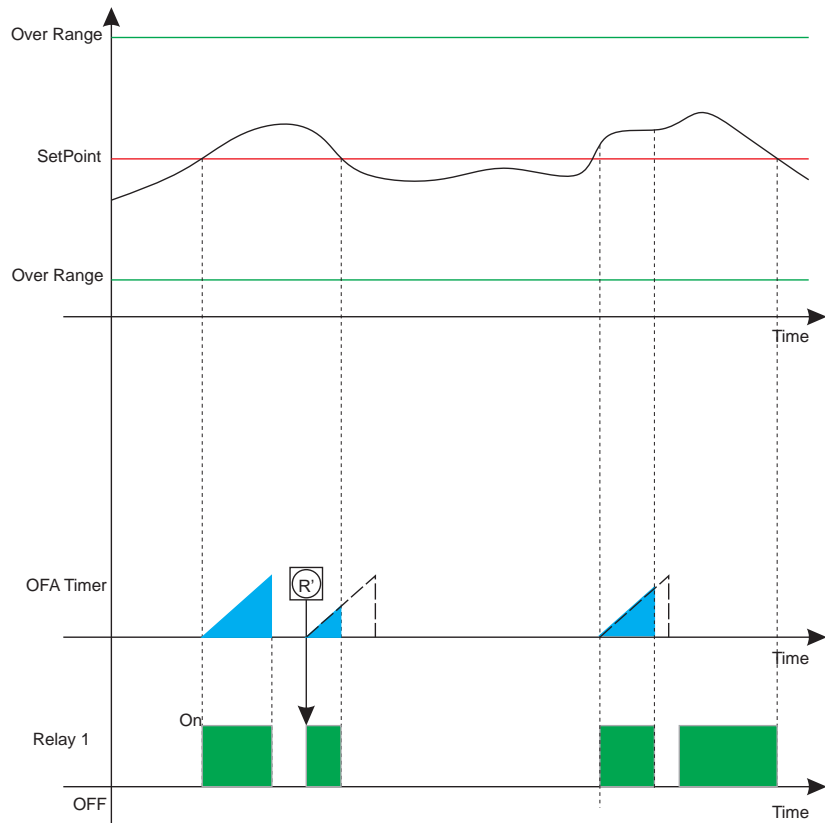

All the settings described on the previous page remain valid.

Note:



- OFA (Over Feed Alarm):** By setting the function “7” OFA with a time in hours and minutes a control timer is activated in parallel to the relay activation. The function checks the activated relay persistence times and generates a visual prealarm at 70% of set value and a blocking alarm (R') at the end of the set time (100%). A manual intervention will be required to remove the blocking with the reset of the OFA function on the alarms menu (see alarms section).

ANNEX B: TIMED RELAY SETUP

Below is an example of settings for the Relay 1 or 2 to adjust the pH by dosing acid chemical product using the timed method.

2A RELAY_1 Timed	
1: SetPoint	7.20 pH
2: Type	Acid
3: Hysteresis	0.00 pH
4: Hyst. Time	00' 00"
5: Delay Start	00' 00"
6: Delay End	00' 00"
7: OFA	OFF
8: Over Range	OFF
9: Time On	01' 00"
10: Time Off	01' 00"

01/10

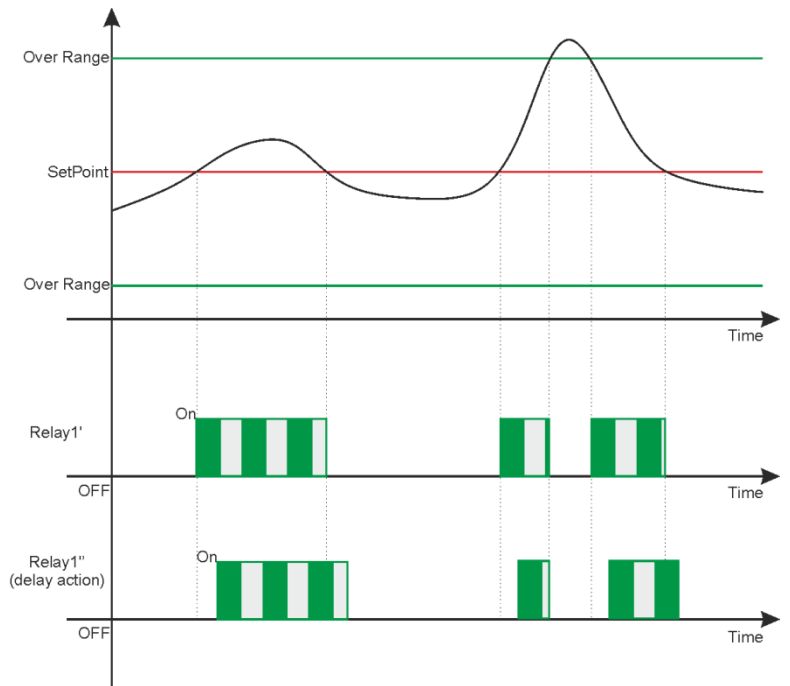

Note:



- **Relay Activation:** When the measure (black line) exceeds the SetPoint the relay is activated and the times On and Off are executed as set on the menu items "10" and "11"; this status is maintained until the measure decreases at the SetPoint value (see relay 1').
- **Delay Activation:** By setting the menu items "5" and "6" the relay activation will be delayed equal to the set time (see relay 1")
- **Chemical Measure out of range:** When the measure (black line) exceeds the maximum or minimum Over Range value (green line), the system displays a visual alarm and blocks the dosage by changing the status of the relay 1 or 2.

ALKA Function: By setting the menu item "2" with the variable ALKA (Alkaline) the relays activations are inverted compared to the above diagram.

Hysteresis Function: By setting the menu items "3" and "4" the instrument maintains the relay activation status both for the chemical measure value and for the time.

ANNEX B: TIMED RELAY SETUP WITH OFA FUNCTION.

Below is an example of settings for the Relay 1 or 2 to adjust the pH by dosing acid chemical product using the timed method.

2A RELAY_1 Timed	
1: SetPoint	7.20 pH
2: Type	Acid
3: Hysteresis	0.00 pH
4: Hyst. Time	00'00"
5: Delay Start	00'00"
6: Delay End	00'00"
7: OFA	OFF
8: Over Range	OFF
9: Time On	01' 00"
10: Time Off	01' 00"

01/10

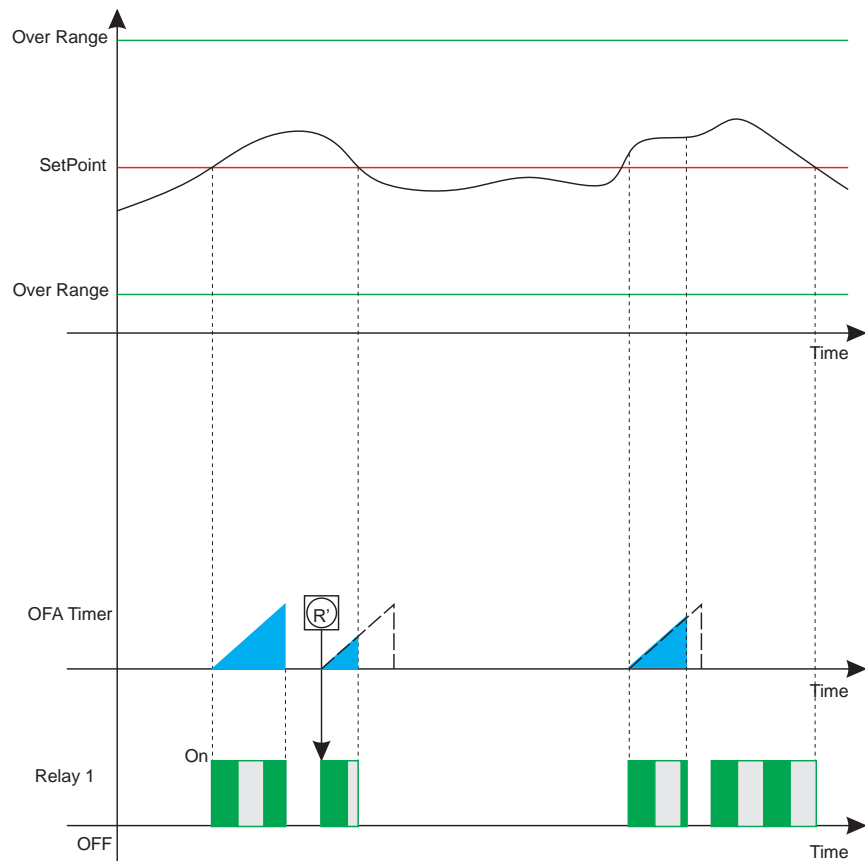

All the settings described on the previous page remain valid.

Note:



- OFA (Over Feed Alarm):** By setting the function "7" OFA with a time in hours and minutes a control timer is activated in parallel to the relay activation. The function checks the activated relay persistence times and generates a visual prealarm at 70% of set value and a blocking alarm (R') at the end of the set time (100%). A manual intervention will be required to remove the blocking with the reset of the OFA function on the alarms menu (see alarms section).

ANNEX C: PROPORTIONAL (PWM) RELAY SETUP.

Below is an example of settings for the Relay 1 or 2 to adjust the pH by dosing acid chemical product using the proportional (PWM) method.

2A RELAY_1_PWM	
1: SetPoint	7.20 pH
2: Type	Acid
3: Hysteresis	0.00 pH
4: Hyst. Time	00'00"
5: Delay Start	00'00"
6: Delay End	00'00"
7: OFA	OFF
8: Over Range	OFF
9: Interval	02'00"
10: Prop. Band	1.00pH

01/10

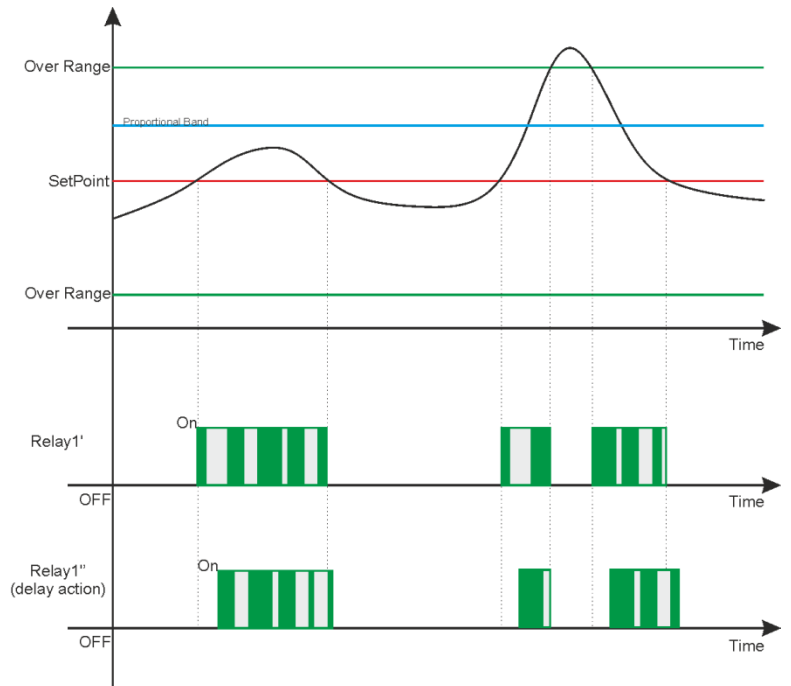

Note:



- **Relay Activation:** When the measure (black line) exceeds the SetPoint the relay is activated and the proportional times On and Off are executed as calculated in relation to the proportional band set in the menu items "10" and "11"; this status is maintained until the measure decreases at the SetPoint value (see relay 1').
- **Delay Activation:** By setting the menu items "5" and "6" the relay activation will be delayed equal to the set time (see relay 1'')
- **Chemical Measure out of range:** When the measure (black line) exceeds the maximum or minimum Over Range value (green line), the system displays a visual alarm and blocks the dosage by changing the status of the relay 1 or 2.

ALKA Function: By setting the menu item "2" with the variable ALKA (Alkaline) the relays activations are inverted compared to the above diagram.

Hysteresis Function: By setting the menu items "3" and "4" the instrument maintains the relay activation status both for the chemical measure value and for the time.

ANNEX C: PROPORTIONAL (PWM) RELAY SETUP WITH OFA FUNCTION

Below is an example of settings for the Relay 1 or 2 to adjust the pH by dosing acid chemical product using the proportional (PWM) method

2A RELAY_1_PWM	
1: SetPoint	7.20 pH
2: Type	Acid
3: Hysteresis	0.00 pH
4: Hyst. Time	00'00"
5: Delay Start	00'00"
6: Delay End	00'00"
7: OFA	OFF
8: Over Range	OFF
9: Interval	02'00"
10: Prop. Band	1.00pH

01/10

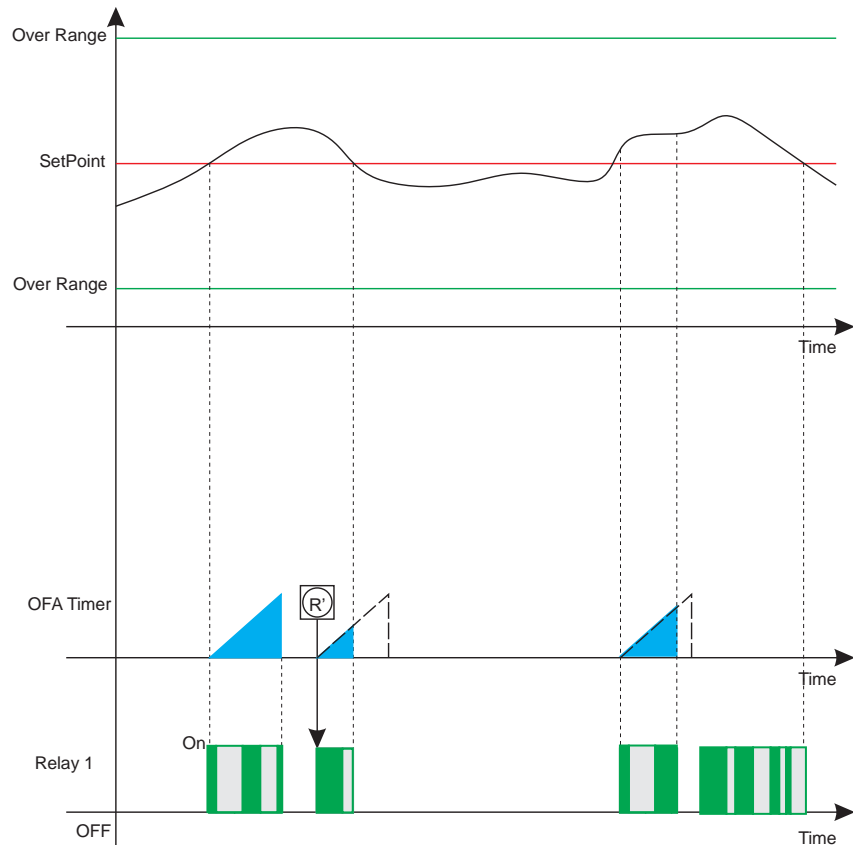

All the settings described on the previous page remain valid.

Note:



- OFA (Over Feed Alarm):** By setting the function "7" OFA with a time in hours and minutes a control timer is activated in parallel to the relay activation. The function checks the activated relay persistence times and generates a visual prealarm at 70% of set value and a blocking alarm (R') at the end of the set time (100%). A manual intervention will be required to remove the blocking with the reset of the OFA function on the alarms menu (see alarms section).

ANNEX D: RELAY 2 SETUP FOR AUTOMATIC WASHING

Below is an example of settings for Relay 2 with Washing function to automate the probe cleaning with an external device(*).

2B Wash	
▶ 1: Wash	05' 00"
2: Delay	05' 00"
3: Wait	06h 00m

01/3

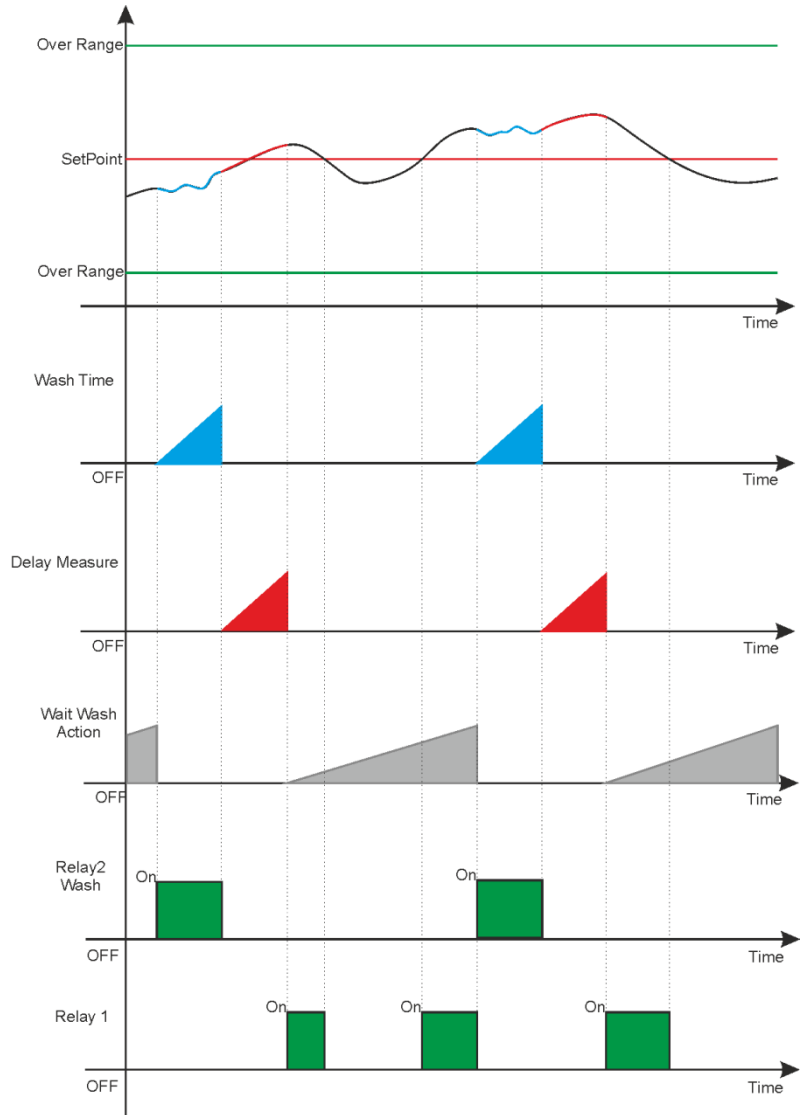

Note:

- **Wash Time:** Relay 2 is activated at the end of "Wait New Wash" timer and starts operating an external device to the set time. The instrument displays a service message by deleting the displayed measure and blocking all the instrument's functions (Amber color Backlight).
- **Delay Measure:** Relay 2 is turned off for the set time by displaying the measure and maintaining all the instrument's functions blocked (Light Green Backlight).
- **Wait New Wash:** The instrument counts the set time by performing the normal functions of measure and control; when the time expires, the "Wash Time" is activated.

ANNEX E: RELAY 2 SETUP TO REPEAT REMOTE ALARM.

(*To set the Relay 2 for Remote Alarm see Advanced Setup Menu 3G)

On Setup Menu 2B it is possible to set the alarm conditions to be repeated by Relay 2; attention, check the Advanced Menu "3F" Alarms Configuration

2B Relay 2	
▶ 1: R1 OverRng	NO
2: R1 OFA	NO
3: Reed Alarm	NO
6: Temp. Alarm	NO
01/04	

3F Alarms_Conf.	
▶ 1: Reed Logic	NA
2: Reed Delay	00'00"
3: Block	No
4: Alarm Temp.	Notify
01/04	

Table with the alarm messages displayed by the instrument.

Number	Alarm	Message	Status
1	Not Present	No Item	
2	External Reed Input Active	Reed	Alarm with instrument blocking (*)
3	Temperature Sensor Broken or Disconnected	Alarm Fault Temp	Alarm with instrument blocking (*)
4	Relay 1 Timer decreased at 70%	OFA1 R1	Preliminary Alarm
5	Relay 2 Timer decreased at 100%	OFA2 R1	Alarm with instrument blocking (*)
6	Chemical Measure outside of working range	Over Range R1	Alarm with instrument blocking (*)
7	Relay 2 Timer decreased at 70%	OFA1 R2	Preliminary Alarm
8	Relay 2 Timer decreased at 100%	OFA2 R2	Alarm with instrument blocking (*)
9	Chemical Measure outside of working range	OverRange R2	Alarm with instrument blocking (*)

(*All the alarms with blocking function are valid if the menu item 3F5 is equal to YES)

(**The temperature sensor breakage alarm blocks the instrument if the menu item 3F6 is equal to YES)

Note:



- **Reset Alarms:** On view Measure (Meas Icon) there is available an Alarm status menu; by pressing the **Enter** key, the **Alarms Menu** will be displayed.



Note: The alarms are stored in memory every 15 minutes, if the instrument is switched off loses alarms displayed in the last 14 minutes.

ANNEX F: SSR1 SETUP

Proportional frequency output with independent Proportional Band and SetPoint.

2C		SSR1	
▶ 1: SetPoint		7.40pH	
2: Type		Acid	
3: Pulse Max		400	
4: Pulse min		1	
5: Prop. Band		0.20pH	

01/05

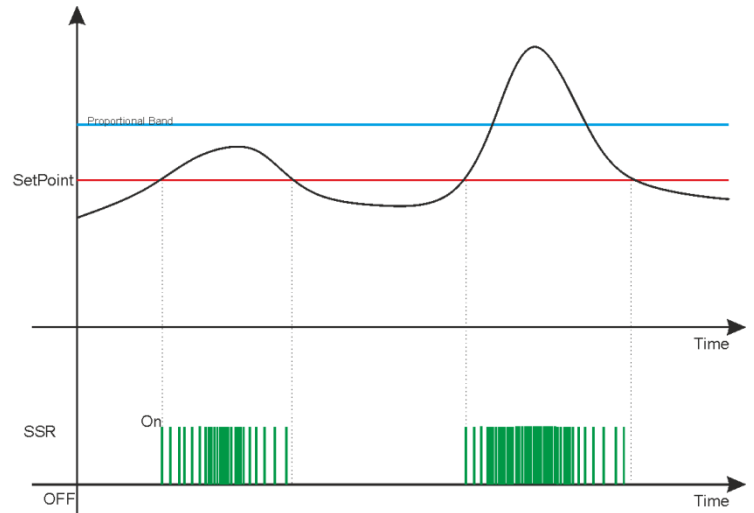

Note:

- **Pulse Max:** Set the maximum value of pulses for chemical measure higher than the proportional band value.
- **Pulse min:** Set the minimum value of pulses for measure near the SetPoint value.
- **Pulse Technical Data:** Pulse On duration is fixed at 100mSeconds and time Off duration varies from 50mS (400 pulses per minute) to 59900mS (1 pulse per minute).



Notes: The Alarm Over Range function is not present on frequency output.

ANNEX G: MA1 SETUP

Current output proportional to the measure with range from 4 mA to 20 mA.

2D	mA1
▶ 1: Start mA	0.00pH
2: End mA	14.00pH
3: Hold	NO
4: Namur	OFF
01/04	

2D	mA1
▶ 1: Start mV	-2000 mV
2: End mV	+2000 mV
3: Hold	NO
4: Namur	OFF
01/04	

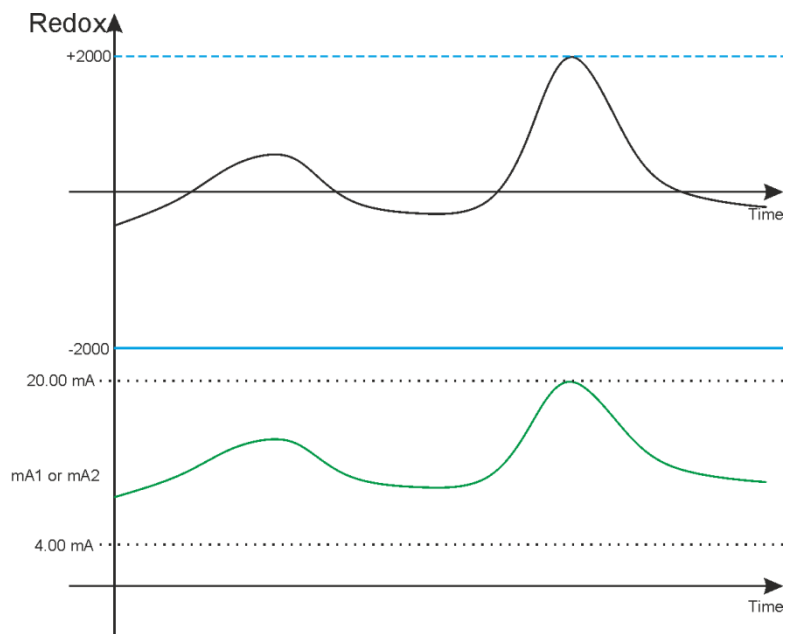
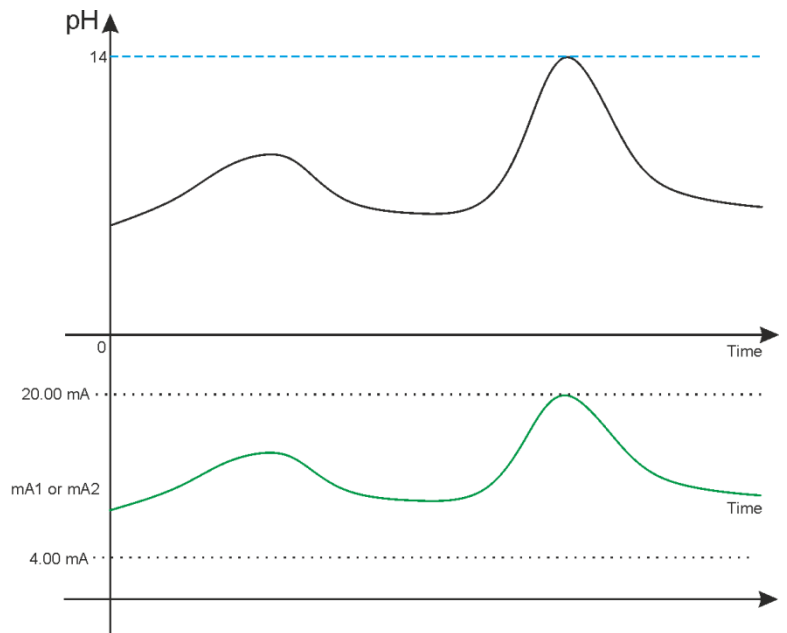

Note:



- **Start mA:** Minimum value of chemical measure associated to 4 mA
- **End mA:** Maximum value of chemical measure associated to 20 mA
- **Hold:** By setting the variable to YES, in case of alarm the instrument freezes the mA output to the last calculated value with Holding Alarm.
- **Namur:** By setting the variable to the value of 3.6 mA or 22 mA, in case of alarm the instrument sets the current output to the selected value.



ANNEX H: WIRING EXAMPLES

Power Supply:

- 230Vac, 115Vac or 24Vac 50/60Hz; check the product label
- Observe the polarity
- Maximum Power Consumption 3,6VA

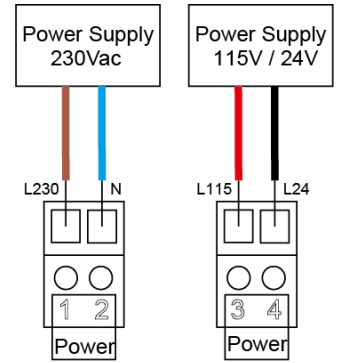

Frequency outputs SSR1 and SSR2:

- Contact closed approx. 3Ω, 100mA maximum load.

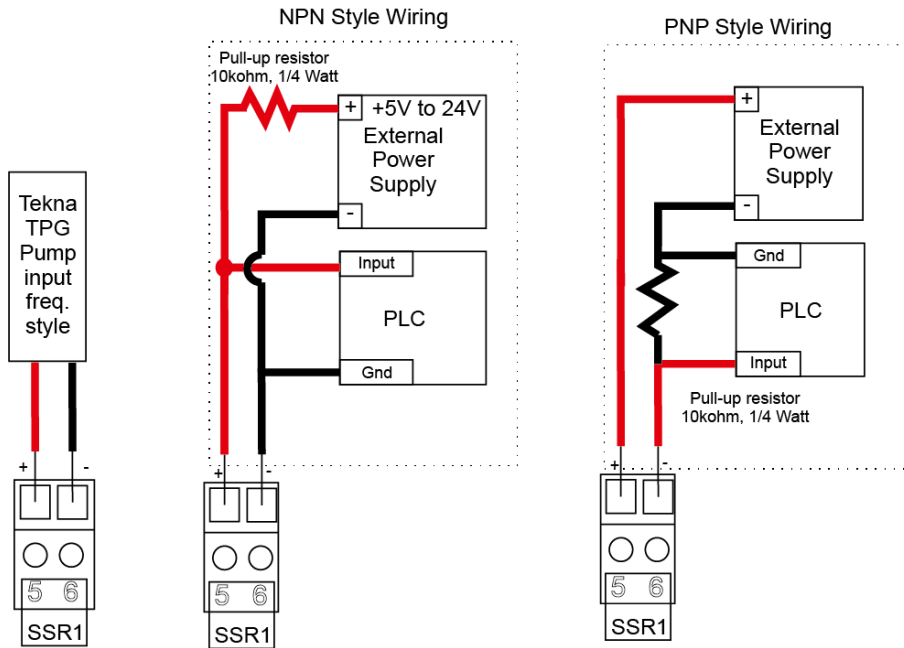

Relay outputs 1 and 2:

- Maximum load 5 A resistive

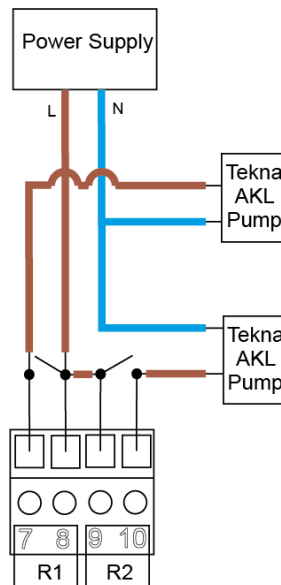

Current output mA 1:

- 4÷20mA with a maximum load of 500 ohm
- Observe the polarity of the cables

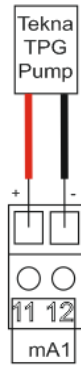

Reed sensor input:

- Input for dry contact or semiconductor (Open Collector) 5Vcc, max 6mA.
- Maximum distance of the Reed sensor 20 meters of cable.

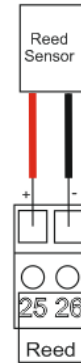

Temperature measure input:

- Attention, connect the probes with metal terminals
- Observe the polarity
- Maximum distance of the PT100/PT1000 sensor 20 meters of cable
- Observe the wiring for the sensor 2, 3 and 4; connect as indicated

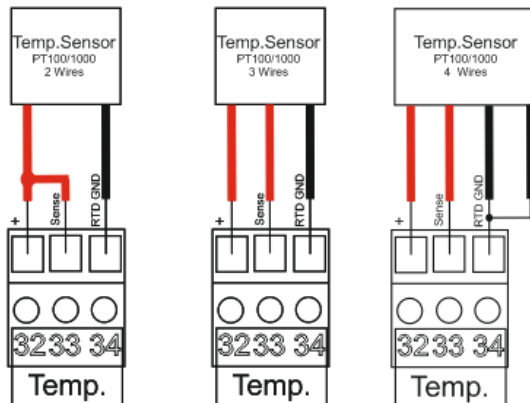

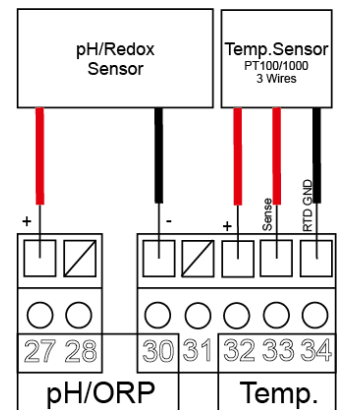
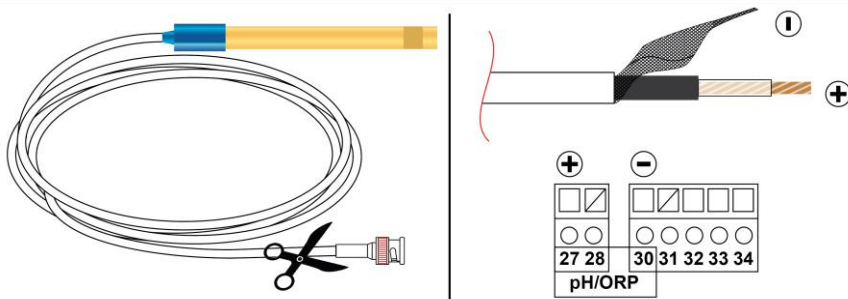

pH/ORP measure input:

- Attention, connect the probes with metal terminals
- Observe the polarity
- Maximum distance of the pH/ORP sensor 10 meters of cable.



ANNEX I: TROUBLESHOOTING

Problem	Possible Cause
The display shows the symbol 	<ul style="list-style-type: none"> • See ANNEX E
Calibration	<ul style="list-style-type: none"> • Contaminated buffer solutions (old) • Probe damaged or old • Probe cables damaged • Measure input of the instrument damaged
Data Memory Error	<ul style="list-style-type: none"> • Internal memory broken
Password Error	<ul style="list-style-type: none"> • Error value
Temperature Measure Error the display shows 	<ul style="list-style-type: none"> • Temperature probe broken or disconnected
Chemical Measure Error	<ul style="list-style-type: none"> • Sensor not calibrated • Sensor not installed correctly • Temperature compensation incorrectly set or disabled • The sensor or the cable is defective • Electronic measure input damaged • The sensor cable exceeds the maximum length
Measure reading not stable	<ul style="list-style-type: none"> • Sensors or cables installed too close to devices that generate electrical noise. • Sensor installed on flow with hydraulic turbulence. • Average measure set too low. • Probe cables excessively long
Unable to display the Calibration or Setup menu	<ul style="list-style-type: none"> • User excluded for safety reasons
The display is turned off	<ul style="list-style-type: none"> • The instrument does not receive correct power supply. • LCD contrast is not set correctly. • The fuse has blown. • Hardware fault.
The display shows in the upper right corner "Diagnostic"	<ul style="list-style-type: none"> • Turn the instrument off and then on again; if the problem persists, contact your provider

ANNEX L: DEFAULT PARAMETERS TABLE AND RESET TO DEFAULT

ADVANCED MENU					
Parameter	Sub-parameter	Default Value	Min Value	Max Value	Unit
Language	---	EN (English)	EN, FR,IT,DE,ES,CN		
Password	Password	0000	0000	9999	
	Cal Menu	NO	NO	YES	
	Setup Menu	NO	NO	YES	
Display	Contrast	0	-15	+15	
	Mode	ECO	OFF, ON, ECO		
	ON	100	10	100	%
	ECO	50	0	50	%
	Inversion	OFF	OFF	ON	
Chemical Meas.	Measure Unit	pH	pH	mV	
	Temp. Compensation	MTC	MTC	ATC	
	Filter	Medium	Low, Medium, High		
Temperature Meas.	Sensor Type	Manual	Manual	External	
	Measure Unit	°C	°C	°F	
	Manual Value	25,0 (77,0)	0,0 (32,0)	+100,0 (212,0)	°C (°F)
	Filter	Medium	Low, Medium, High		
Alarm Setting	Reed Logic	NA	NA	NC	
	Delay Activation REED	OFF	OFF 00':00")	60':59'	min:sec
	Instrument blocking	NO	NO	YES	
	Temperature Alarm	Notification	Notification	Block	
Output Setting	Relay 1	OFF	OFF, Meas ON/OFF, Meas Timed, Meas. PWM		
	Relay 2	OFF	OFF, Meas ON/OFF, Meas Timed, Meas. PWM, Temp. ON/OFF, Temp. Timed, Temp. PWM, Probe Wash, Alarm		
	SSR1	OFF	OFF, Measure, Temp.		
	mA1	OFF	OFF, Measure, Temp.		
Control Panel	Chemical Measure	---	-2100	+2100	mV
	Temperature Measure	---	0,0	+100,0	°C
	Simul. Relay 1	OFF	OFF	ON	
	Simul. Relay 2	OFF	OFF	ON	
	Simul. Freq 1	0	0	400	Imp/min
	Simul. Out mA 1	4,00	3,00	23,00	mA
	REED Input	---	OFF	ON	
Statistics	No. Startups	0	0	9999999	Activations
	No. Alarms	0	0	9999999	Activations
	No. RL1 Activations	0	0	9999999	Activations
	No. RL2 Activations	0	0	9999999	Activations
	No. REED Activations	0	0	9999999	Activations
	Reset Statistics	NO	NO	YES	
System Reset	---	NO	NO	YES	
Firmware Revision	---	---	---	---	

SETUP MENU					
Parameter	Sub-parameter	Default Value	Min Value	Max Value	Unit
Relay 1 = OFF, Relay 2 = OFF, SSR1 = OFF, mA1 = OFF					
Relay 1	---	OFF	---	---	
Relay 2	---	OFF	---	---	
SSR1	---	OFF	---	---	
mA1	---	OFF	---	---	

SETUP MENU		Chemical Measure Unit: pH				
Parameter	Sub-parameter 1	Sub-parameter 2	Default Value	Min Value	Max Value	Unit
Relay 1 / Relay 2 pH ON/OFF	SetPoint	---	7,40	0,00	14,00	pH
	Type	---	Acid	Acid	Alkaline	
	Hysteresis	---	0,00	0,00	2,00	pH
	Hysteresis Time	---	OFF	OFF (00':00")	2':59"	min:sec
	Delay Start	---	00':01"	OFF (00':00")	60':59"	min:sec
	Delay End	---	00':01"	OFF (00':00")	60':59"	min:sec
	OFA	---	OFF	OFF (00h:00')	23h:59'	ore:min
	Over Range	---	OFF	OFF (0,00)	14,00	pH
Relay 1 / Relay 2 pH TIMED	Time On	---	00':10"	OFF (00':00")	60':59"	min:sec
	Time Off	---	00':10"	OFF (00':00")	60':59"	min:sec
Relay 1 / Relay 2 pH PWM	Interval	---	02':00"	OFF (00':00")	60':59"	min:sec
	Proportional Band	---	0,20	0,20	3,00	pH

SETUP MENU		Chemical Measure Unit: mV				
Parameter	Sub-parameter 1	Sub-parameter 2	Default Value	Min Value	Max Value	Unit
Relay 1 / Relay 2 mV ON/OFF	SetPoint	---	750	-2000	2000	mV
	Type	---	High	Low	High	
	Hysteresis	---	0	0	200	mV
	Hysteresis Time	---	OFF	OFF (00':00")	2':59"	min:sec
	Delay Start	---	00':01"	OFF (00':00")	60':59"	min:sec
	Delay End	---	00':01"	OFF (00':00")	60':59"	min:sec
	OFA	---	OFF	OFF (00h:00')	23h:59'	hours:min
	Over Range	---	OFF	-2000	2000	mV
Relay 1 / Relay 2 mV TIMED	Time On	---	00':10"	OFF (00':00")	60':59"	min:sec
	Time Off	---	00':10"	OFF (00':00")	60':59"	min:sec
Relay 1 / Relay 2 mV PWM	Interval	---	02':00"	OFF (00':00")	60':59"	min:sec
	Proportional Band	---	20	20	300	mV

SETUP MENU		Temperature Measure Unit: °C				
Parameter	Sub-parameter 1	Sub-parameter 2	Default Value	Min Value	Max Value	Unit
Relay 2 °C ON/OFF	SetPoint	---	25,0	0,0	100,0	°C
	Type	---	Low	Low	High	
	Hysteresis	---	0,0	0,0	10,0	°C
	Hysteresis Time	---	OFF	OFF (00':00")	2':59"	min:sec
	Delay Start	---	00':01"	OFF (00':00")	60':59"	min:sec
	Delay End	---	00':01"	OFF (00':00")	60':59"	min:sec
	OFA	---	OFF	OFF (00h:00')	23h:59'	hours:min
	Over Range	---	OFF	OFF (0,0)	100,0	°C
Relay 2 °C TIMED	Time On	---	00':10"	OFF (00':00")	60':59"	min:sec
	Time Off	---	00':10"	OFF (00':00")	60':59"	min:sec
Relay 2 °C PWM	Interval	---	02':00"	OFF (00':00")	60':59"	min:sec
	Proportional Band	---	10,0	1,0	50,0	°C

SETUP MENU		Temperature Measure Unit: °F				
Parameter	Sub-parameter 1	Sub-parameter 2	Default Value	Min Value	Max Value	Unit
Relay 2 °F ON/OFF	SetPoint	---	77,0	32,0	212,0	°F
	Type	---	Low	Low	High	
	Hysteresis	---	0,0	0,0	18,0	°F
	Hysteresis Time	---	OFF	OFF (00':00")	2':59"	min:sec
	Delay Start	---	00':01"	OFF (00':00")	60':59"	min:sec
	Delay End	---	00':01"	OFF (00':00")	60':59"	min:sec
	OFA	---	OFF	OFF (00h:00')	23h:59'	hours:min
	Over Range	---	OFF	OFF (0,0)	180,0	°F
Relay 2 °F TIMED	Time On	---	00':10"	OFF (00':00")	60':59"	min:sec
	Time Off	---	00':10"	OFF (00':00")	60':59"	min:sec
Relay 2 °F PWM	Interval	---	02':00"	OFF (00':00")	60':59"	min:sec
	Proportional Band	---	18,0	1,8	90,0	°F

SETUP MENU		Relay 2 = Probe Wash				
Parameter	Sub-parameter 1	Sub-parameter 2	Default Value	Min Value	Max Value	Unit
Relay 2 pH/mV Wash	Wash Time	---	OFF	OFF (00':00")	60':59"	min:sec
	Delay Stabilization	---	01':00"	OFF (00':00")	60':59"	min:sec
	Wait New Wash	---	24h:00'	OFF (00h:00')	99h:59'	hours:min

SETUP MENU		Relay 2 = Alarm				
Parameter	Sub-parameter 1	Sub-parameter 2	Default Value	Min Value	Max Value	Unit
Relay 2 Alrm	Over Range R1	---	NO	NO	YES	
	OFA R1	---	NO	NO	YES	
	Alarm REED	---	NO	NO	YES	
	Alarm Temperature Probe	---	NO	NO	YES	

SETUP MENU		Chemical Measure Unit: pH				
Parameter	Sub-parameter 1	Default Value	Min Value	Max Value	Unit	
SSR1 pH	SetPoint	7,40	0,00	14,00	pH	
	Type	Acid	Acid	Alkaline		
	Max Pulses	400	20	400	Imp/min	
	Min Pulses	1	1	100	Imp/min	
	Proportional Band	0,20	0,20	3,00	pH	

SETUP MENU		Chemical Measure Unit: mV				
Parameter	Sub-parameter 1	Default Value	Min Value	Max Value	Unit	
SSR1 mV	SetPoint	750	-2000	2000	mV	
	Type	High	Low	High		
	Max Pulses	400	20	400	Imp/min	
	Min Pulses	1	1	100	Imp/min	
	Proportional Band	20	20	300	mV	

SETUP MENU		Temperature Measure Unit: °C				
Parameter	Sub-parameter 1	Default Value	Min Value	Max Value	Unit	
SSR1 °C	SetPoint	25,0	0,0	100,0	°C	
	Type	Low	Low	High		
	Max Pulses	400	20	400	Imp/min	
	Min Pulses	1	1	100	Imp/min	
	Proportional Band	10,0	1,0	50,0	°C	

SETUP MENU		Temperature Measure Unit: °F			
Parameter	Sub-parameter 1	Default Value	Min Value	Max Value	Unit
SSR1 °F	SetPoint	77,0	32,0	212,0	°F
	Type	Low	Low	High	
	Max Pulses	400	20	400	p/min
	Min Pulses	1	1	100	Imp/min
	Proportional Band	18,0	1,8	90,0	°F

SETUP MENU		Chemical Measure Unit: pH			
Parameter	Sub-parameter 1	Default Value	Min Value	Max Value	Unit
mA1 pH	Start mA	0,00	0,00	14,00	pH
	End mA	14,00	0,00	14,00	pH
	Hold Measure	NO	NO	YES	
	Namur	OFF, 3,6mA, 22 mA			

SETUP MENU		Chemical Measure Unit: mV			
Parameter	Sub-parameter 1	Default Value	Min Value	Max Value	Unit
mA1 mV	Start mA	-2000	-2000	2000	mV
	End mA	2000	-2000	2000	mV
	Hold Measure	NO	NO	YES	
	Namur	OFF, 3,6mA, 22 mA			

SETUP MENU		Temperature Measure Unit: °C			
Parameter	Sub-parameter 1	Default Value	Min Value	Max Value	Unit
mA1 °C	Start mA	0,0	0,0	100,0	°C
	End mA	100,0	0,0	100,0	°C
	Hold Measure	NO	NO	YES	
	Namur	OFF, 3,6mA, 22 mA			

SETUP MENU		Temperature Measure Unit: °F			
Parameter	Sub-parameter 1	Default Value	Min Value	Max Value	Unit
mA1 °F	Start mA	32,0	32,0	212,0	°F
	End mA	212,0	32,0	212,0	°F
	Hold Measure	NO	NO	YES	
	Namur	OFF, 3,6mA, 22 mA			

RESET THE DEFAULT PARAMETERS OF THE INSTRUMENT

To load all the default parameters of the instrument and also remove the password, proceed as follows:

- Disconnect the instrument from the power supply
- Press and hold simultaneously **Down** and **Enter** and power the instrument.
- At startup the instrument will execute a hidden menu
- Will be displayed the following message (picture on the Side)
- Select "YES" to perform the **RESET TO DEFAULT**.
- The instrument turns on and performs the **STARTUP** function.

