

POINT OBSTRUCTION CONTROLLER POC TOUCHSCREEN CONTROLLERS FOR LED LIGHTING SYSTEMS

Compliances: FAA Advisory Circular 70/7460-1L
ICAO Annex 14, Volume I, Chapter 6

The POC controller provides the control and monitoring functions for an LED red obstruction lighting system. This lighting system warns pilots to stay clear of the obstruction to air navigation when installed in accordance with FAA AC 70/7460-1 and applicable FCC and ICAO rules and recommendations. Together with PFB flashing LED beacons and POL red LED low intensity lights, the POC powers and monitors an integrated obstruction lighting system. One PPC FAA photoelectric controller (order separately) provides automatic lighting activation.

Number & Types of Lights

Controller	Medium Intensity	Low Intensity	Touchscreen
POC-68002-04-x	none	1 – 4 POL	optional
POC-68002-08-x	none	1 – 8 POL	optional
POC-68002-08-6 (277v input)	none	1 – 8 POL	optional
POC-68002-x	none	custom	optional
POC-60301-10-x	1 PFB Red only	none	no *
POC-60301-18-x	1 PFB Red only	1 – 8 POL	no *
POC-60301-30-x	3 PFB Red only	none	no *
POC-60301-38-x	3 PFB Red only	1 – 8 POL	no *
POC-60301-40-x	4 PFB Red only	none	no *
POC-60301-48-x	4 PFB Red only	1 – 8 POL	no *
POC-68003-90-x	1 – 9 PFB Red only	none	optional
POC-68003-94-x	1 – 9 PFB Red only	1 – 4 POL	optional
POC-68003-98-x	1 – 9 PFB Red only	1 – 8 POL	optional
POC-68003-x	custom	custom	optional
POC-68503-90-x	1 – 9 PFB White or Dual	none	yes
POC-68503-94-x	1 – 9 PFB Dual	1 – 4 POL	yes
POC-68503-98-x	1 – 9 PFB Dual	1 – 8 POL	yes
POC-68503-x	custom	custom	yes
POC-68504-1	custom	custom	yes

* Basic controller with limited options. Data cable is not required. One alarm light per beacon. Suitable for one flashing PFB or multiple beacons Type C or with options –MA1M & –MA1S.
** The only 277v input POC; output is 120v; the POL's must be 120v.



Note: For all systems with PFB-38111 high intensity white beacons.

The number of POL lights is counted by the number of alarm lines, not the number of operating heads. A primary-standby PFB pair counts as one beacon. POL-S2 singles and –D2 doubles each count as one POL.

Power Input –x: 1: 120v 2: 208-240v 3: 12v DC 4: 24v DC 5: 48v DC

AC controllers operate at 50 Hz or 60 Hz. Controllers 68002, 68003 & 60301 may be any AC & DC voltage above. Controller 68503 cannot be 12v or 24v DC, but may be 48v DC. Controller 68504 is for universal AC power only.



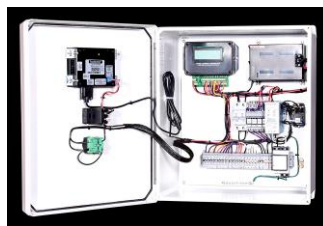

































POC-68002-04-1-TS





FEATURES & AVAILABLE OPTIONS

 Available
 Standard

Option	Description	68002	68003	68503
TS	Touchscreen consisting of color TFT touch panel display that displays current status and automatically lists an alarm condition. It is a 3.5-inch in color, outdoor rated NEMA 4X and has a brightness of 400cd/m2. The touchscreen is controlled by a PLC Programmable Logic Controller. POC's without a touchscreen include one general red alarm light on the door.			
EX	Class 1, Division 2 (Zone 2) Note: No touchscreen on any hazardous area controller.			
AX	ATEX & IECEx zones 1 & 2 Note: No touchscreen on any hazardous area controller.			
UPS or BBS	Uninterruptible Power Supply (UPS) & Battery Backup System (BBS) for power continuity. It may be a separate enclosure for some systems. For UPS, the lights will be 120V AC; for BBS, the lights will be 12V DC.			
PFA	Power Failure Alarm: If power is lost, this relay will de-energize and close its corresponding dry (voltage free) contact. Requires a remote power source on the line (by others).			
SA	System Activity Status: Upon activation of the POC (ON), the contact of the red lighting system will close and signal a remote monitor (by others). Requires a remote power source on the line (by others). For addition of a yellow pilot light on the door, use option –SA1			
LA	Lightning Arrestor is added internally and wired across the power input to protect the power source. Clamps a maximum current of 60,000 amps. Response time to clamp 50KA is 25 nanoseconds.			
FP	Flashing POL's: The low intensity lights and any red beacons flash in sync.			
LK	Padlock Door Hasp is added to the standard fiberglass enclosure allowing the use of a padlock (by others).			
SS	Stainless Steel Enclosure Note: Not available with option –EX.			
PPA	PPC photoelectric control alarm. After 24 hours without any change of mode, the alarm is activated. For white and dual systems only.			
BZ	Audible Indicator (Buzzer) for alarm notification. Includes switch on the door to override the buzzer.			
SB	Required when standby beacons are connected. The PFB-SB has the same data address as the primary beacon.			
PTT	Push-To-Test pilot lights. Not used with touchscreen or EX or AX.			
PD	Passive Display as an internal LCD display			



POINT OBSTRUCTION CONTROLLER POC TOUCHSCREEN CONTROLLERS FOR LED LIGHTING SYSTEMS

UNINTERRUPTIBLE POWER SUPPLY: OPTION –UPS

Typically used for systems with PFB red beacons, the UPS option acts as an uninterruptible power supply battery backup for the LED lighting system supplied by Point Lighting Corporation. Upon failure of the normal power, the UPS will automatically switch to its standby power source with a run-time of at least 30 minutes*. Upon restoration of power, the UPS automatically returns to steady-state.

*Additional third party loads must not be connected to the UPS. Contact Point Lighting Corporation for review of customization feasibility for longer time periods and different loads.

The voltage code used for the POC catalog number is the available commercial voltage. For either 120V or 220-240V commercial AC power, the POC-UPS will output 120V AC to the load circuits. The UPS may be in a separate enclosure mounted next to the POC enclosure.

Typically used with a POC-68003 or POC-60301 system controller switched by a PPC-40700 FAA photoelectric controller for automatic operation.

Number of PFB Beacons	Approximate Operating Time
One (1)	8 hours
Two (2)	5 hours
Three (3)	3.5 hours
Four (4)	2 hours

BATTERY BACKUP SYSTEM: OPTION –BBS

The Battery Backup System option is used for systems of POL-21005 red LED aviation obstruction lights connected to a POC-68002 system controller. The PPC-40003 FAA photoelectric controller provides automatic activation at dusk in accordance with FAA specifications.

The BBS is connected to normal AC commercial power. Upon loss of the AC power, the BBS switches to battery power for unattended operation. The battery stays fully charged automatically under normal AC input power to the POC. The battery is not depleted during normal AC power as the BBS uses an inverter.

The voltage code used for the POC catalog number is the available input voltage. For either 120V or 220-240V commercial AC power, the POC-BBS will output 12V DC to the load circuits. The BBS is in the POC enclosure but may be in a separate enclosure for larger custom systems.

Number of POL Lights	Approximate Operating Time
1 to 3	All Night
4 to 7	> 6 hours
7 to 9	> 4 hours

Minimum Wire Size Chart (AWG)

Circuit Run Length	Operating Heads								
	1	2	3	4	5	6	7	8	9
100-ft wire size:	16	16	16	16	14	14	14	14	12
200-ft wire size:	16	16	14	14	12	12	10	10	10

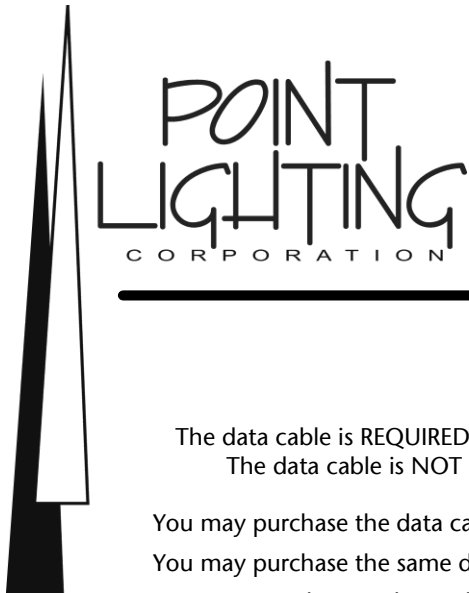

POINT OBSTRUCTION CONTROLLER POC TOUCHSCREEN CONTROLLERS FOR LED LIGHTING SYSTEMS

DATA CABLE

The data cable is REQUIRED for systems using POC-68003, POC-68503 and POC-68504 controllers.
The data cable is NOT required for systems using POC-68002 and POC-60301 controllers.

You may purchase the data cable from Point Lighting under stock number PL10836.

You may purchase the same data cable from others as Belden 9207 Twinax – Twinaxial Cable.

You may purchase a data cable from others equal to the above Belden cable with the characteristics listed below. Note: You are responsible to confirm the specifications are equal to the above cable which was used during certification testing. Use of inferior cable may result in improper operation of the system.

The data cable is used as one (1) run from the POC controller to the beacon #1 junction box and then to each beacon junction box in turn ("daisy-chain") that terminates at the last numbered beacon. The beacons are numbered in sequence and MUST be installed on the data cable in that sequence. This allows the POC system controller to identify and monitor each beacon and synchronize the flashing.

The data cable is a data bus and may be routed as required with the numbered beacons connected at any point. Each beacon is tagged and labeled with a location address number and the beacons must be connected to the data cable run in that numerical order.

PL10836-S shield solder sleeve is required to terminate shield at junction boxes or in-line splice the data cable. See Figure 5 below excerpted from our instructions.

Specifications for your cable supplier:

20 AWG stranded (7x28) one tinned copper conductor, one bare copper conductor, polyethylene (PE) insulation, PE inner jacket, metal foil-polyester taped shield 100% coverage, tinned copper braid shield 85% coverage, PVC outer jacket, suitable for outdoor use, UL maximum operating voltage 300V RMS.

Conductors: Single pair (2 wires); #20 AWG; 7x28 strand

Insulation: Polyethylene

Outer Shield: Metal foil-polyester tape with tinned copper braid

Standard: NEC/UL CMG & CL2 with CE mark

Impedance: 100 ohms Inductance: 0.155 μ H/ft VP: 66% Delay: 1.54 ns/ft

Capacitance conductor to cond.: 14.5 pF/ft Capacitance cond. to shield: 23.0 pF/ft

The shield of the incoming data cable must be terminated with a PL10836-S Solder Sleeve. Using a heat gun, heat the solder sleeve until the solder melts, and the blue band has adhered to the data cable. See [Figure 5](#) for a correct example of this termination. The shield will become the green wire shown in [Figure 5](#).

FIGURE 5
DATA CABLE (PL10836) WITH SOLDER SLEEVE (PL10836-S)



POC OBSTRUCTION CONTROLLER FOR A RED LIGHTING SYSTEM INCLUDING TOUCHSCREEN

POC-68003 SPECIFICATION

The obstruction lighting system shall be controlled by means of a POINT LIGHTING CORPORATION system controller type POC-68003. The standard circuit layout shall be modified to accommodate the lighting system per the project plans.

Features:

- NEMA 4X (IP66) fiberglass enclosure
- Available with optional stainless steel or hazardous location enclosure
- Color touchscreen display
- Input & output circuit breakers
- Prewired rail mounted surge protector
- FAA photoelectric control override switch on the door
- PPC photoelectric control failure alarm after 24 hours without switching (white & dual only)
- Factory programmed for the specific system, but may be field reprogrammed

The POC enclosure shall be rated NEMA 4X (IP66) fiberglass reinforced polyester in gray (RAL 7036) with stainless steel piano hinged door and seamless gasket. The door is to be secured by two captive screws. All components shall be panel mounted. The enclosure may be punched or drilled for conduit entry. The enclosure shall be manufactured by Vynckier and certified to IEC 529, CSA, KEMA and UL 508A Type 4X & 12, IP66 watertight and dust tight.

All internal wiring and component spacing shall comply with the US National Electric Code. All components shall be prewired to IEC terminal blocks. Power shall be single phase measured line to neutral, 50 or 60 Hz.

The POC shall be protected from transient voltage spikes by a DIN-rail mounted surge suppressor with a 50kA maximum surge current to IEC 61643-1.

There shall be one 30mm industrial grade pilot light on the door: green **POWER ON** indicating power is present at the input terminals of the contactor. There shall be a color TFT touch panel display on the door that displays current status and automatically lists an alarm condition. The touchscreen shall be a minimum of 3.5" color outdoor and rated NEMA 4X. The touchscreen shall have a minimum brightness of 400cd/m². The touchscreen shall be controlled by a PLC Programmable Logic Controller. All door mounted components shall be rated for outdoor installation.

There shall be a three (3) position master switch mounted on the door for ON-OFF-AUTO operation. In the AUTO position, the controller shall operate automatically from an FAA photoelectric controller that operates per FAA light level requirements (order PPC separately).

Each load output shall be protected by a DIN-rail mounted current limiting circuit breaker providing thermal magnetic overcurrent protection in accordance with UL, CSA and IEC standards. The UL and IEC rated short circuit capacity shall be 5,000 amps. The breaker is resettable and the status is color coded.

A wiring schematic shall be included with each POC. Legend plates for all devices shall be included. Each POC controller shall be fitted with dry (voltage free) alarm contacts. Alarm contacts shall be N.O. (Normally Open) type.

POC SYSTEM CONTROLLER WITH CLASS I, DIVISION 2 ENCLOSURE POC-68003-90-1-EX

Note: Touchscreen is not available for hazardous areas



TYPICAL RED BEACON SYSTEM AUTOMATIC NIGHT OPERATION WITH FIXED BRIGHTNESS

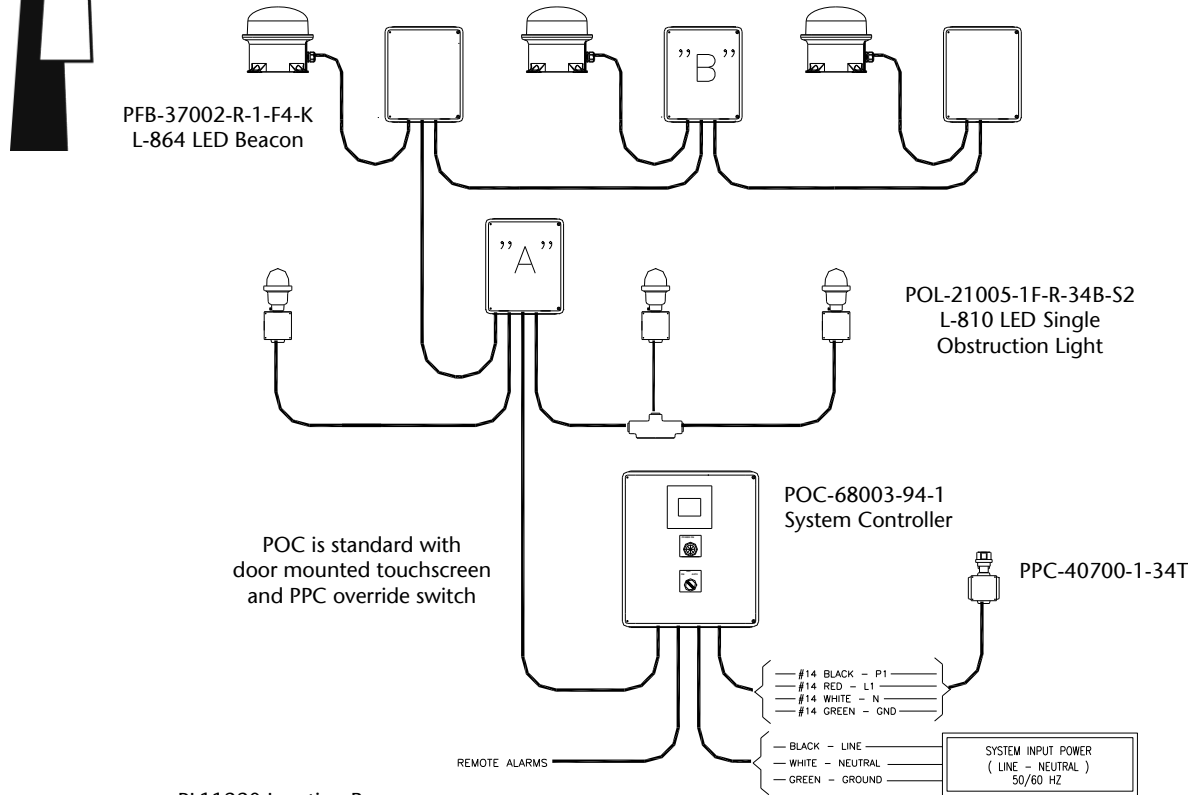

PL11220 Junction Box

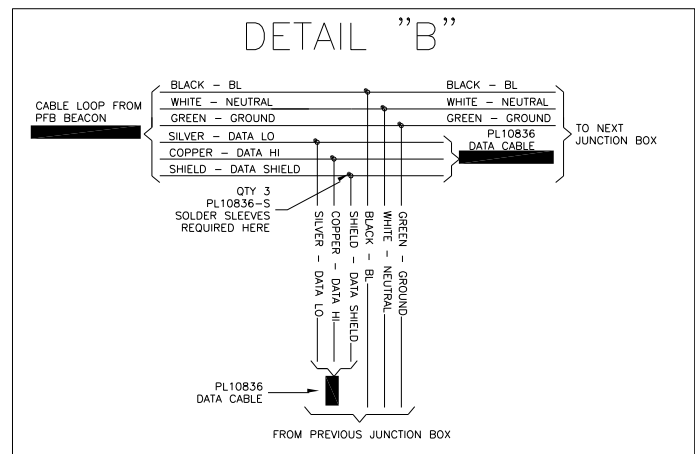
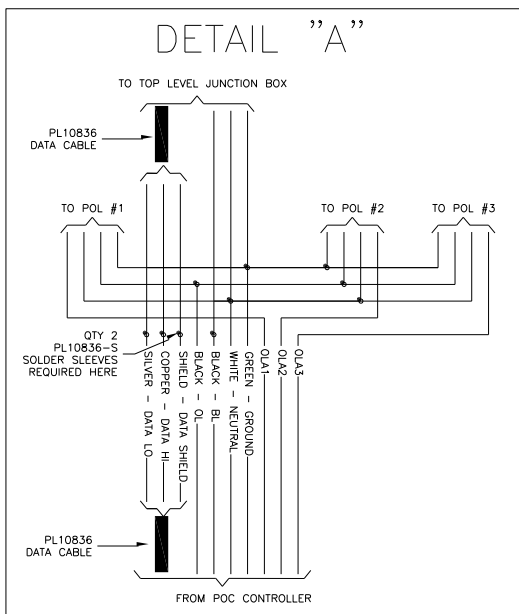

PL11220 Junction Box

TYPICAL WHITE BEACON SYSTEM AUTOMATIC 24-HOUR OPERATION WITH TWO BRIGHTNESS LEVELS

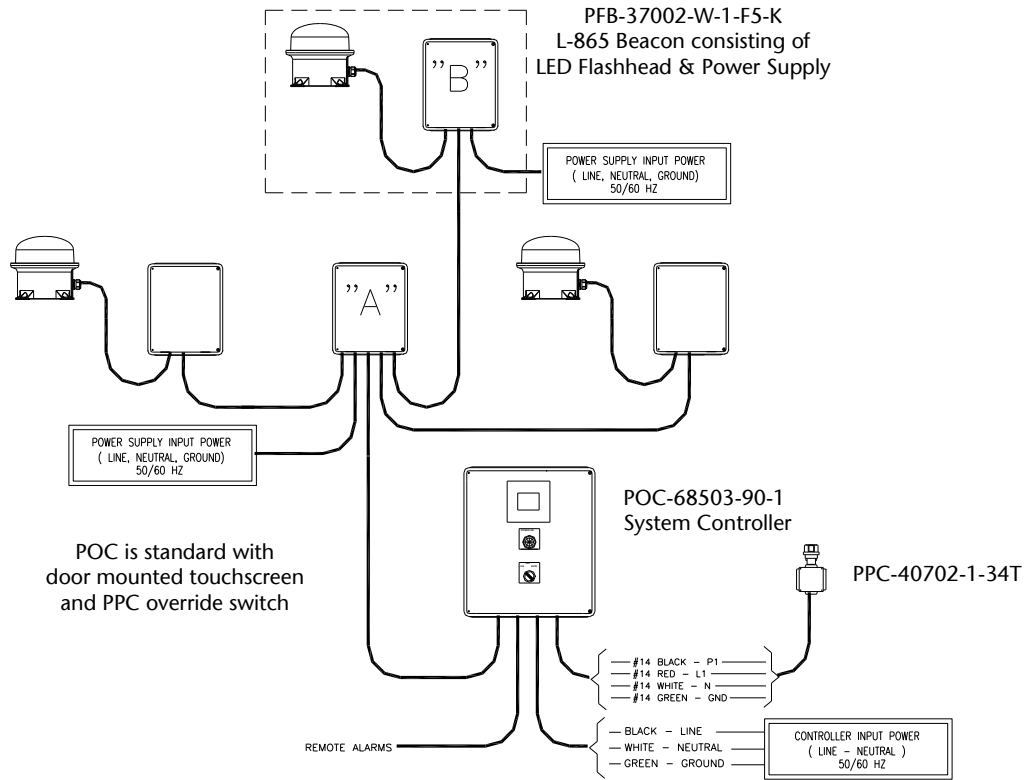

PL11220 Junction Box

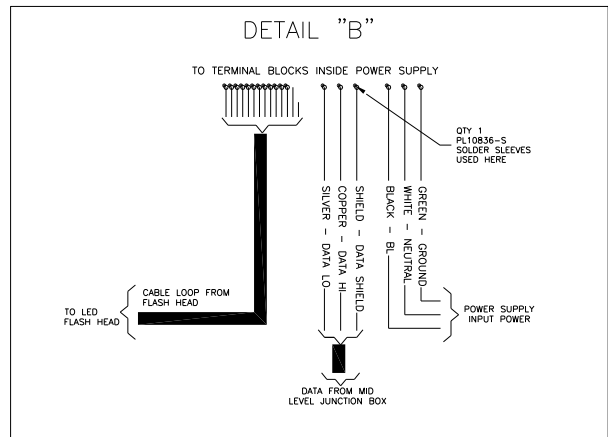
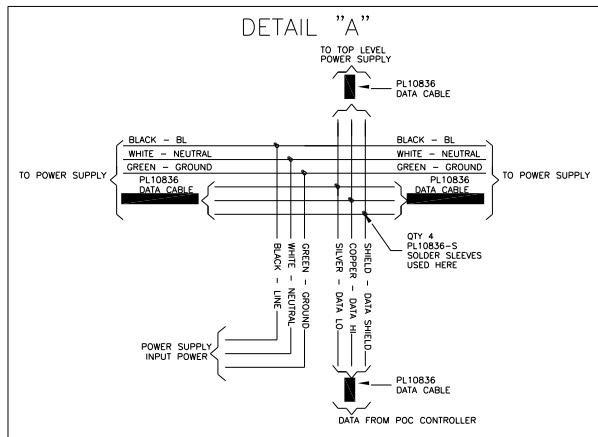

PFB-37002-RW-1-F4F5-K
L-864/865 Beacon consisting of
LED Flashhead & Power Supply

TYPICAL DUAL WHITE & RED BEACON SYSTEM
AUTOMATIC 24-HOUR OPERATION WITH TWO BRIGHTNESS LEVELS

