

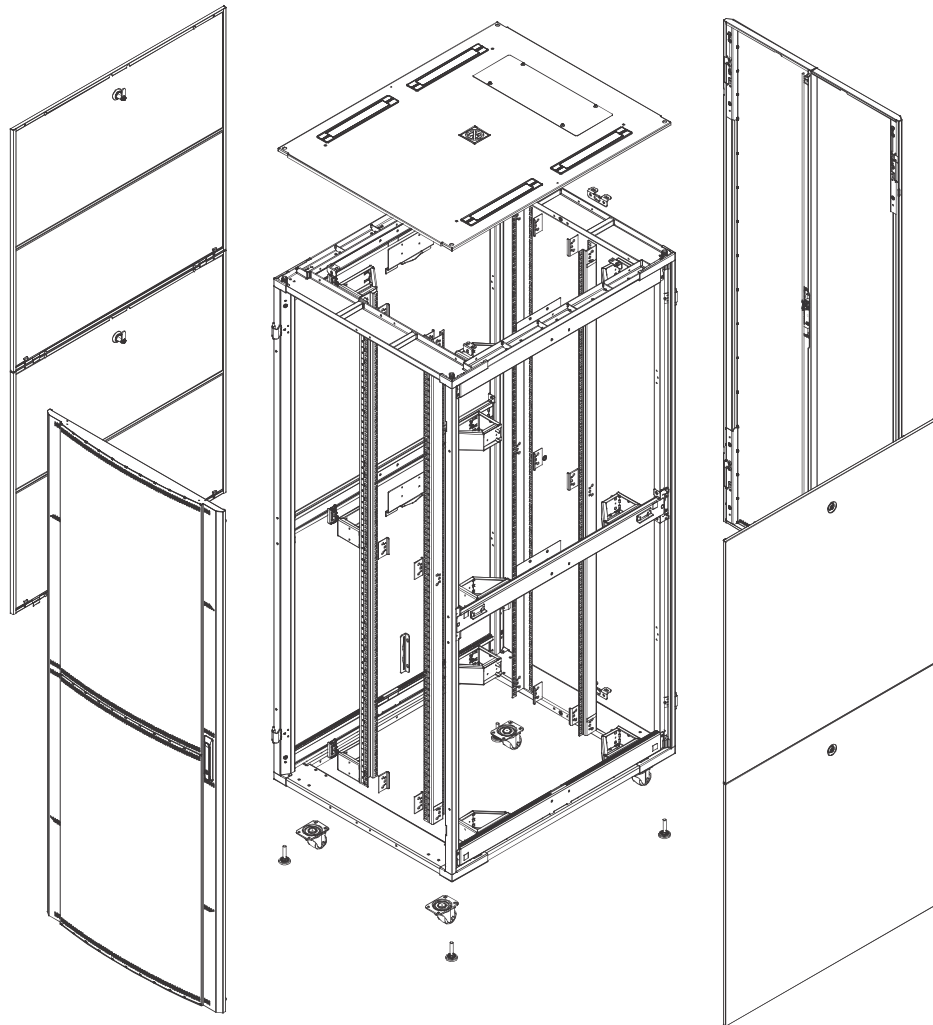

19" Standard Cabinet
Complies to EIA-310-E and IEC-60297-2

Assembly Guide

ARION V2 800W Series



Patents Pending : 1002000994, 1001000784, 1001000785, 1001000786, 1001000787, 1301005921

Contents

Arion V2 800W Exploded View	1
Tools & Hardware	2
Frame Structure Assembly	3
Leveling Feet Assembly	4
Caster Assembly	4
Middle Side Brace Assembly	5
Top Panel Assembly	5
PMA Set Assembly	6
Side Panel Latch Bucket Assembly	7
Side Panel Assembly	7
Front Door Assembly	8
Rear Door Assembly	9
Side Channel Cover Assembly	11
PDU/Vertical Cable Rail Assembly	12
Product Information	13



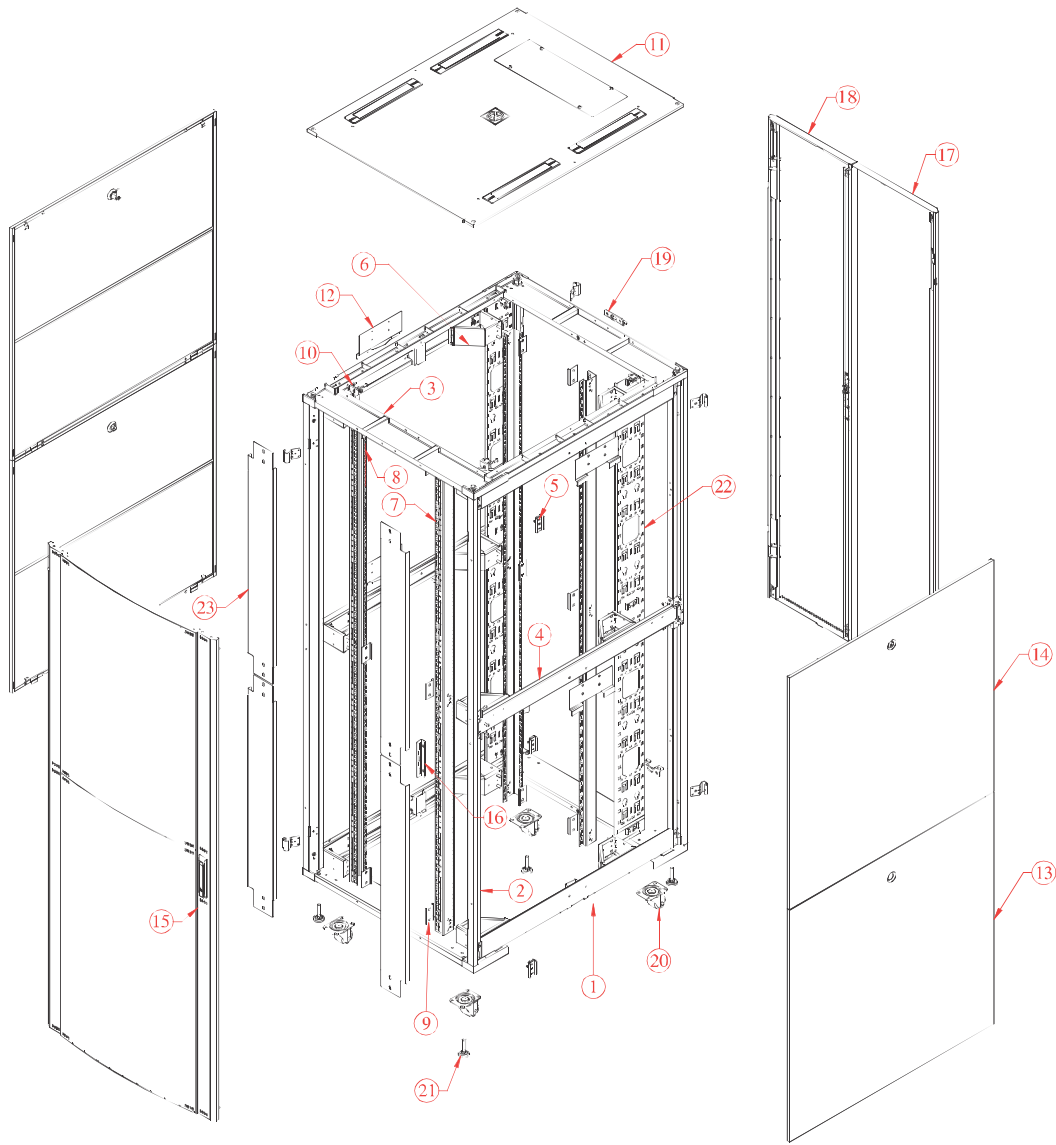

Arion V2 800 Series Enclosure. Basic Unit with Select Optional Parts

Item	Part Name	QTY.
1	Frame (Bottom) 800W/1000D-1200D (V2)	1
2	Vertical Post 33U-48U (V2)	4
3	Frame (Top) 800W/1000D-1200D (V2)	1
4	Side Brace (Mid) 1000D (V2)	2
5	PMA Mounting Brkt.	12
6	PMA Adapter Welded 800W (19IN)	12
7	PMA Assy. (LH) 33U-48U (V2)	2
8	PMA Assy. (RH) 33U-48U (V2)	2
9	PMA Reinf. Plate 800W	12
10	Top Panel Fixing Brkt.	4
11	Top Panel Assy. 800W/1000D-1200D (V2)	1
12	Side Panel Latch Brkt. (V2)	4

Item	Part Name	QTY.
13	Side Panel Bottom Assy. 1000D-1200D/33U-48U (V2)-T05	2
14	Side Panel Top Assy. 1000D-1200D/33U-48U (V2)-T05	2
15	Front Door (Curve) Perforate Assy. 800W/33U-48U (V2)	1
16	Door Latch Brkt. (0352-01)	1
17	Rear Door (Split) Perforate Assy. (LH) 800W/33U-48U (V2)	1
18	Rear Door (Split) Perforate Assy. (RH) 800W/33U-48U (V2)	1
19	Door Split Latch Brkt. (V2)	2
20	Leveling Feet M10x1.50x62	4
21	Caster 2 Inch (optional)	4
22	PDU / Vertical Cable Rail Assy. (optional)	2
23	Side Channel Cover 800W/33U-48U (optional)	4



TOOLS AND HARDWARE

» Tools Recommended for Assembly

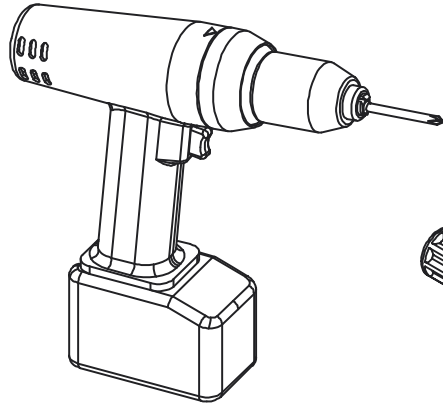

Wireless Screw Driver, Torx Head

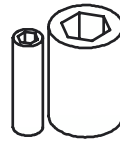

Hexagon Socket No.10, 13,24

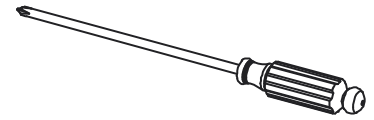

Screwdriver Torx T30

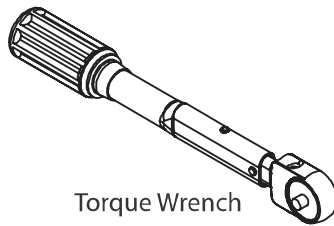

Torque Wrench

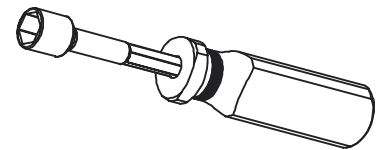

Nut & Screw Driver

» Hardware Supplied by Cheval

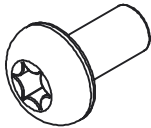

Screw Torx M6x12
29 pcs.



Washer Spring M16
8 pcs.

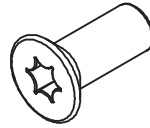

Screw Torx Taper M6
18 pcs.

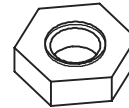

Nut Hex M16, M8
8, 36 pcs.



Nut Flange M6
20 pcs.

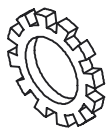

Washer Tooth lock
36 pcs.



Rubber Bumper 4.55 MM.
16 pcs.

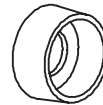

Hinge Bushing
6 pcs.



Washer Flat M16
8 pcs.

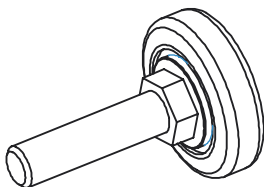

Levelling Feet M10
4 pcs.

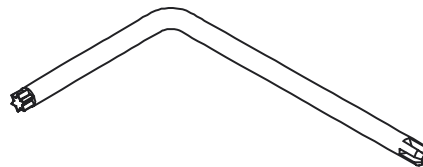

Philips/Torx T30 L-Wrench
1 pc.

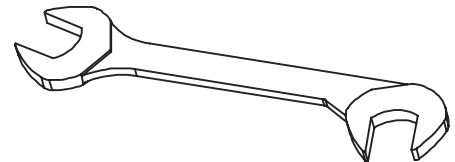

Open End Wrenches NO.10,14
1 pc.

Additional parts included in hardware bag.
Note : Hardware for optional parts.
- Nut Flange M6 16 pcs for Casters.



FRAME STRUCTURE ASSEMBLY

Step 1A: Install vertical frame posts to top and bottom frames see detail A and B (hand tight only).

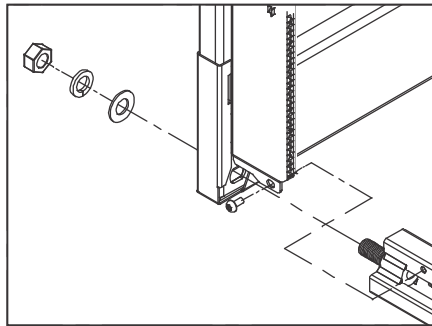

DETAIL A

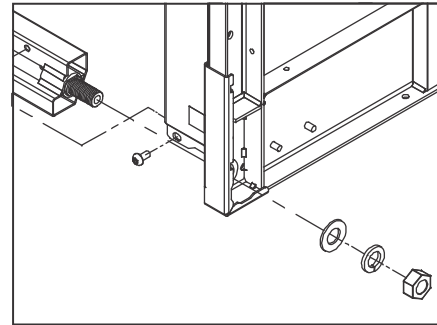

DETAIL B

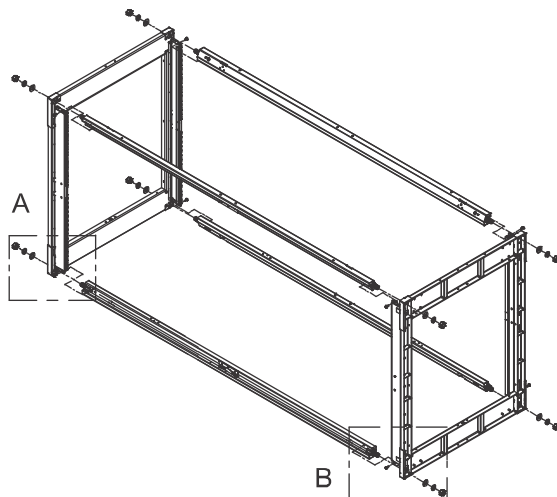

Hardware	Qty.
Flat Washer M16	8
Spring Washer M16	8
Hex Nut M16	8
Torx head screw M6 X 12	8

Step 1B: Fix hex nut M16 and torx head screw M6 x 12.

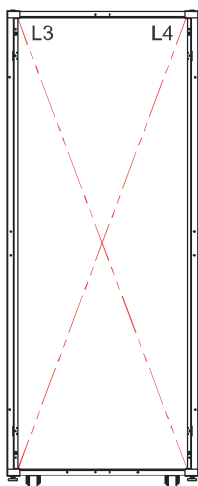

FRONT/REAR Diagonal

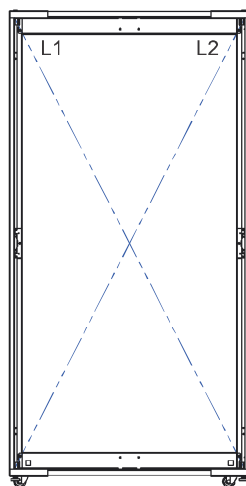

SIDE Diagonal

Using the torque settings below:

65-70 ft.lbs for Hex Nut M16

75-80 in.lbs for Torx head screw M6 x 12

Time required this step : 5 mins.



- Note** : - Before tightening should check diagonal of front and side, dimension between L1=L2 and L3 = L4
- Top Frame and Bottom Frame are different, Pls check before install.
 - If top frame and bottom frame are different (tolerance +/- 2mm), pls check and readjust before installing.



Step 2: Install leveling feet to bottom frame.

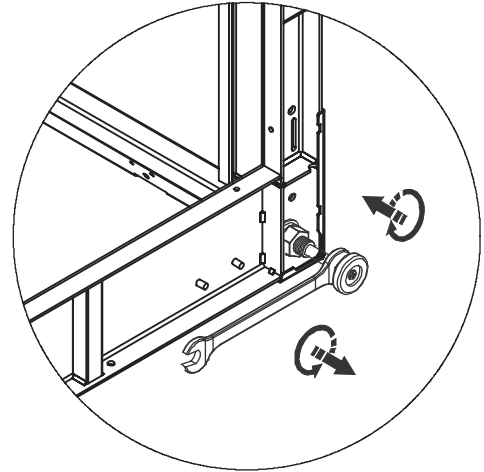
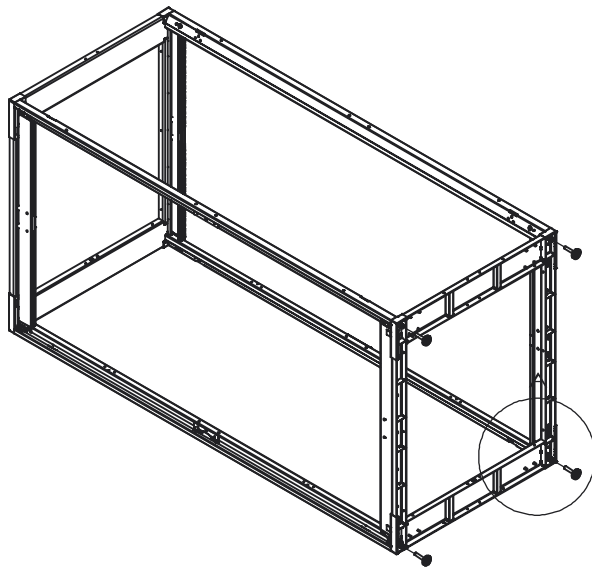

Hardware	Qty.
Leveling Feet	4

Optional Parts : Install casters. See detail C.

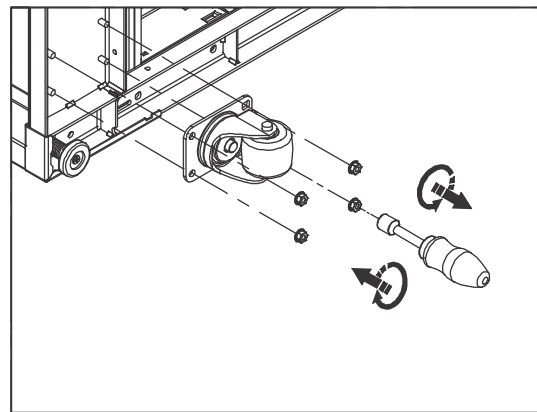
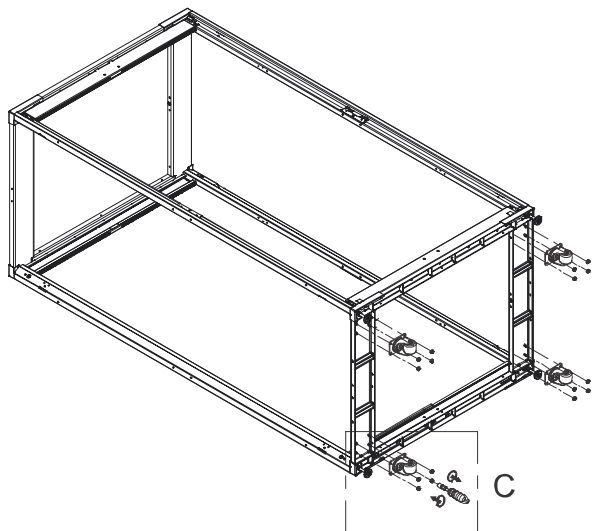

DETAIL C

Hardware	Qty.
Caster 2.0"	4
Flange Nut M6	16

Set Torque 75-80 in.lbs

Time required this step : 2.5 mins.



Step 3: Install middle side brace, two pieces to frame.

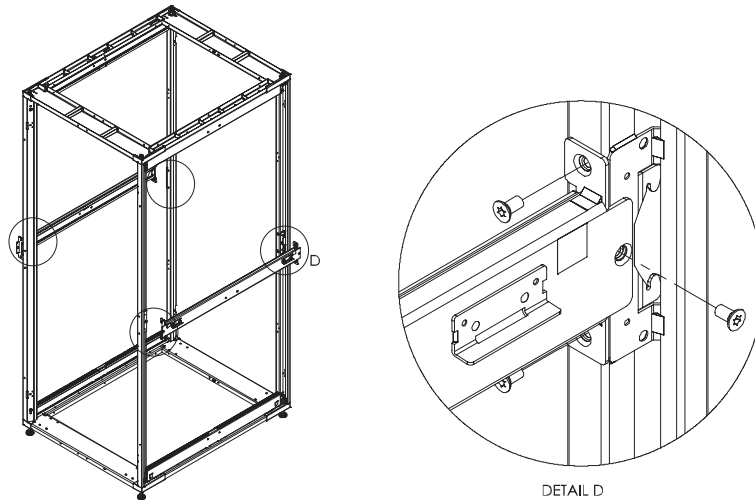

Hardware	Qty.
Screw torx taper M6 x 12	12

Set Torque 75-80 in.lbs

Time required this step : 30 Secs.



TOP PANEL ASSEMBLY

Step 4: Install top panel fixing bracket, 4 pieces to top frame. See detail E1 and E2.
Install top panel to frame top. See detail E3.

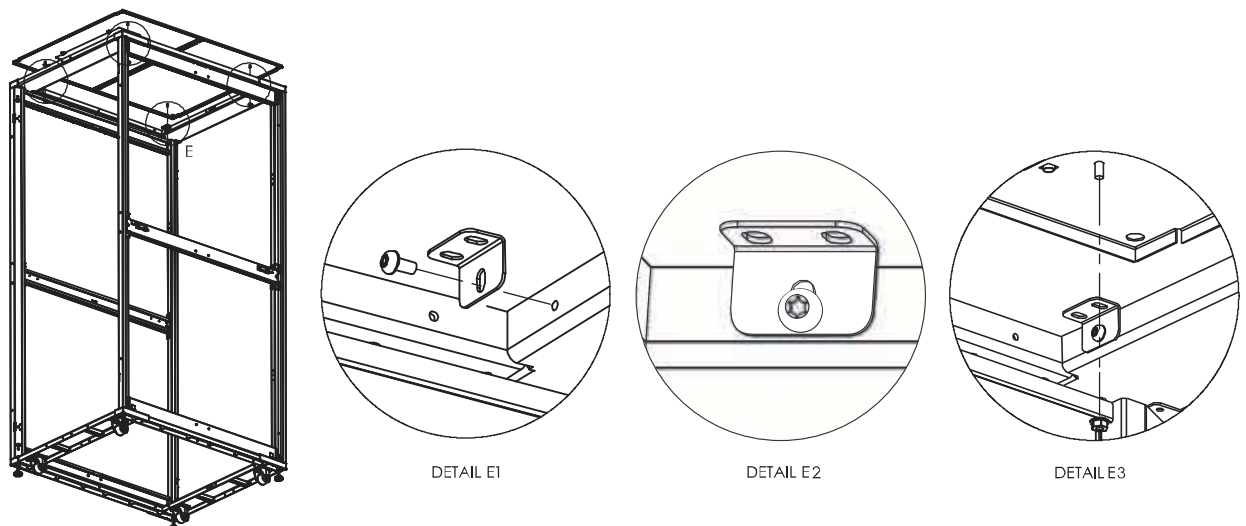

Hardware	Qty.
Torx head screw M6 x 12	4
Top Fixing brkt.	4
Flange Nut M6	4

Note : 2 holes attach to Top Panel.
1 hole attaches to Top Frame.

Time required this step : 1 mins.



PMA SET ASSEMBLY

Step 5A: Install PMA mounting bracket 12 pieces to frame structure
3 pieces / PMA (See detail A1).

Step 5B: Install PMA adapter 12 pieces to frame structure 3 pieces / PMA
(hand tight only). Select position of PMA adapter by using PMA adjust label.

Step 5C: Fix PMA to PMA Adapter (hand tight only). See detail A2.

Step 5D: Fix hex nut M8 setting torque.

- PMA Adapter to frame 50-55 in.lbs
- PMA to PMA Adapter 75-80 in.lbs

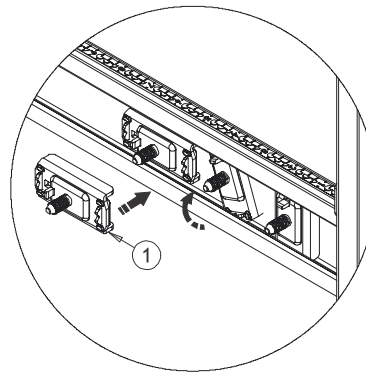
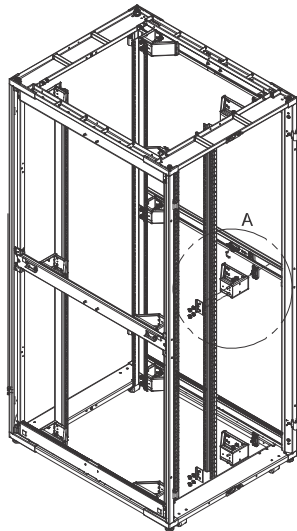

DETAIL A1

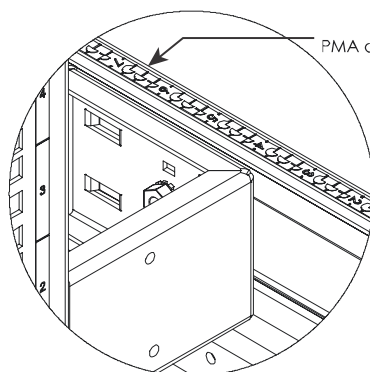

DETAIL A3

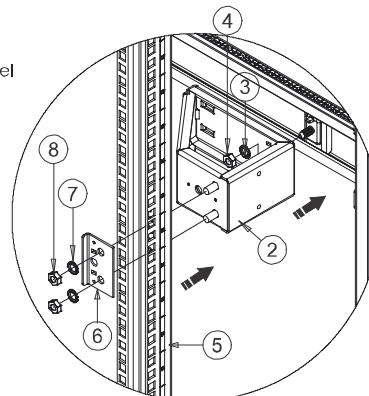

DETAIL A2

	Hardware	Qty.
1	PMA mounting brkt.	12
2	PMA Adapter	12
3,7	Washer Tooth lock M8	36
4,8	Hex nut M8	36
6	PMA Reinf. Plate	12

Time required this step : 10 mins.



SIDE PANEL ASSEMBLY

Step 6: Install the side panel latch bracket at side frame structure.

IMPORTANT:

Pls note there are 4 holes on the side panel latch bracket and follow assembly instructions below. If installed incorrectly, the side panels will not lock correctly.

Install the top latch bracket and use the lower two holes (see detail H).
Install the middle latch bracket and use the top two holes (see detail G).

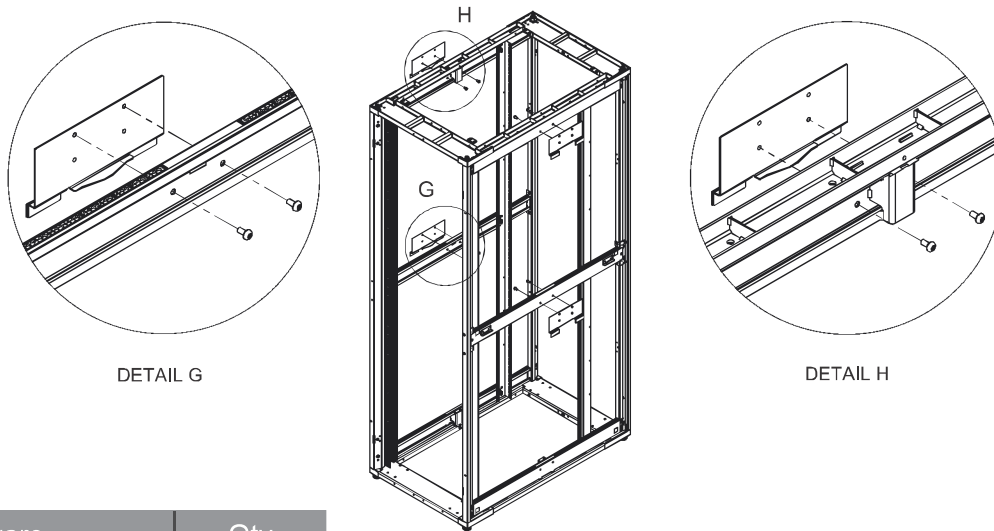

Hardware	Qty.
Torx head screw M6 x 12	8

Set Torque 55-60 in.lbs

Time required this step : 30 Secs.



Step 7: Side Panels are common parts, install bottom side panel.

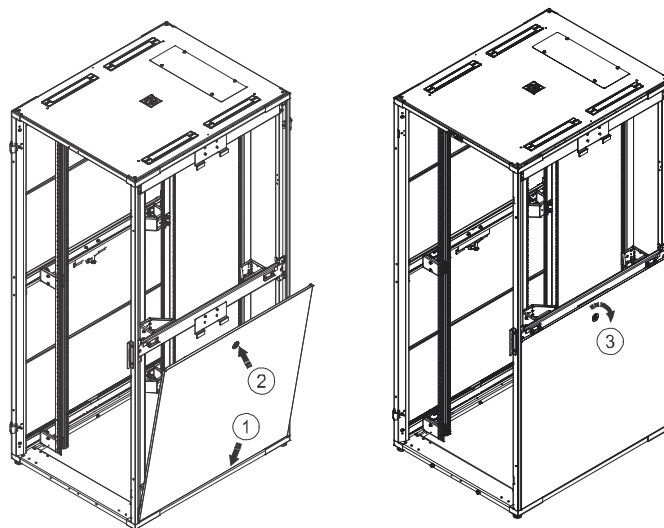

Time required this step : 30 Secs.



Step 8: Install top side panel.

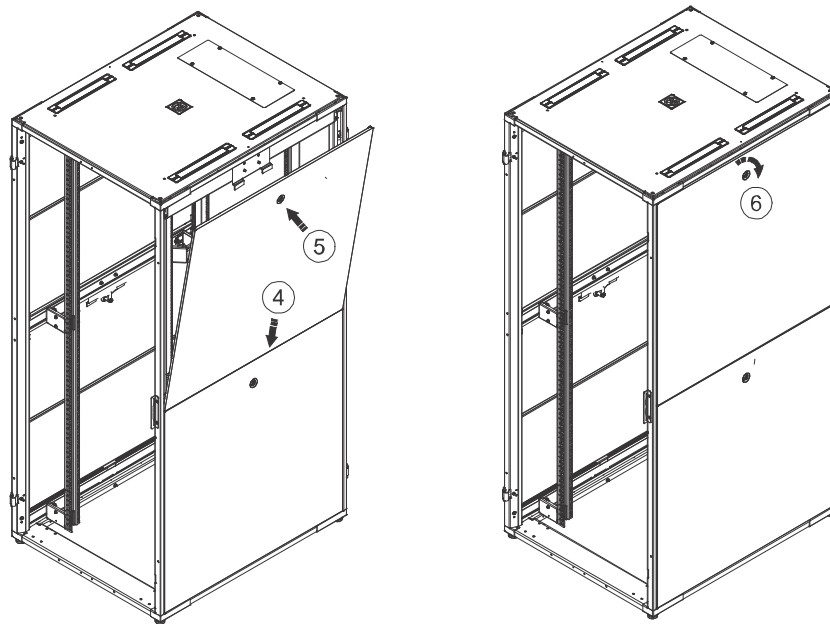

Note : Top and Bottom Side Panels are independent of each other and can be removed as desired.

Time required this step : 30 Secs.



FRONT DOOR ASSEMBLY

Step 9: Install front door hinges 2 pieces (see detail I). Install door latch bracket to front vertical frame (see detail J).

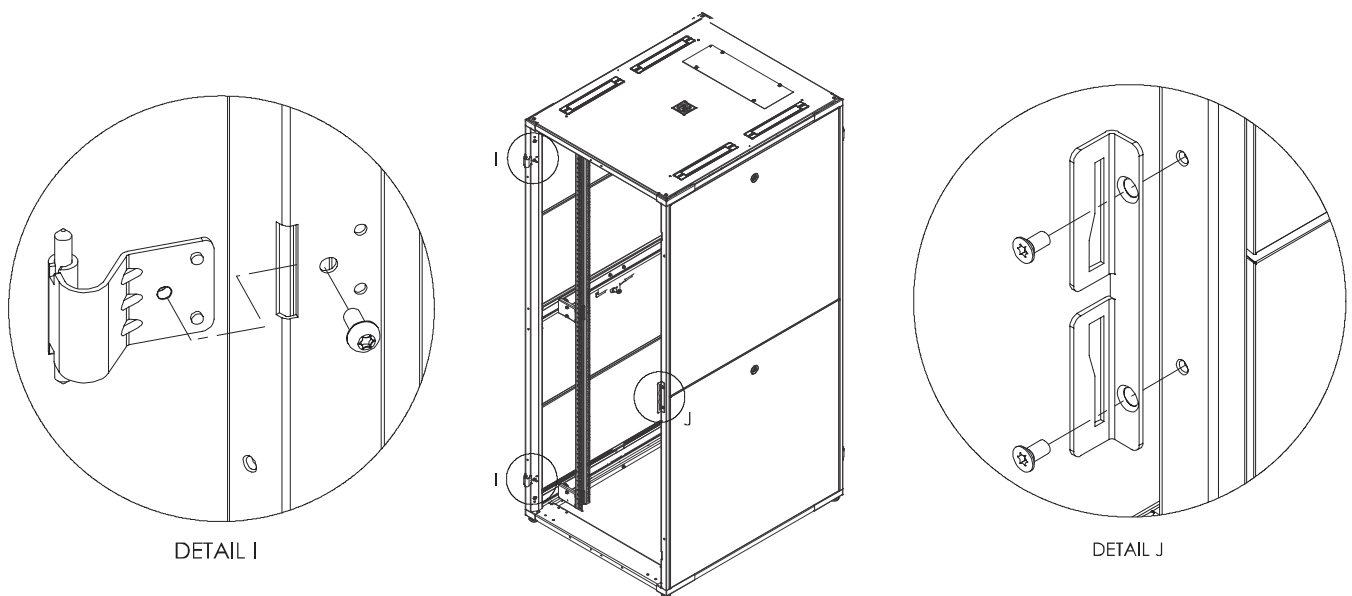

Set Torque 50-55 in.lbs



Step 9A: Insert hinge bushings on both door hinges. Assemble door onto door hinges (see detail K and L). Attach ground wire after door is installed (see detail K).

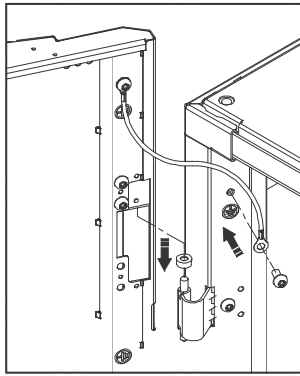

DETAIL K

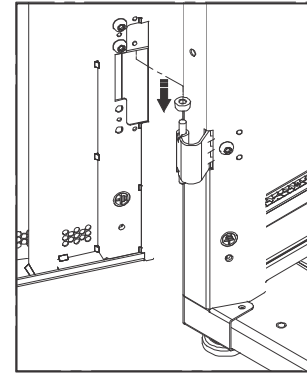
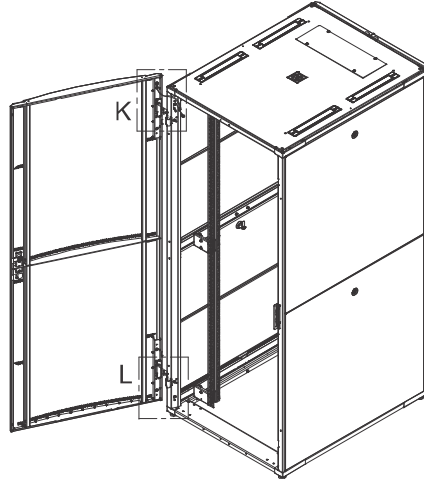

DETAIL L

Hardware	Qty.
Torx head screw M6 x 12	3
Screw torx taper M6 x 12	2
Hinge bush	2

Set Torque 50-55 in.lbs

Time required this step : 2.5 mins.



REAR DOOR ASSEMBLY

Step 10: Install rear door hinges 4 pieces (see detail M). Install split door latch brackets to back vertical post (see detail N).

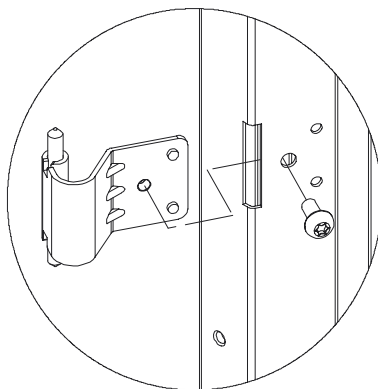

DETAIL M

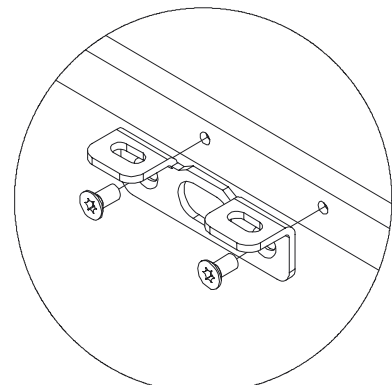
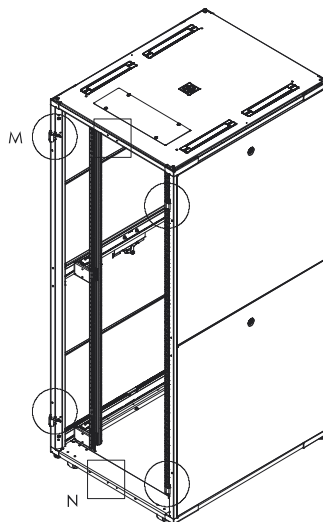

DETAIL N



Step 10A: Ensure front door is perpendicular with top surface of bottom frame. Insert hinge bushing on the four door hinges (see detail O and P). Assemble split doors onto door hinges (see detail O and P). Attach ground wire after doors are installed (see detail O).

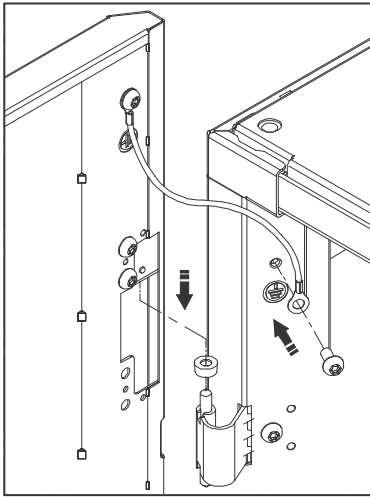

DETAIL O

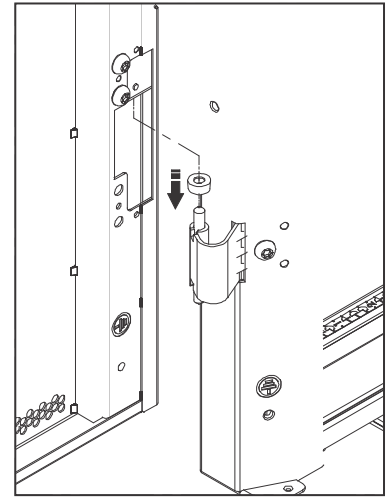
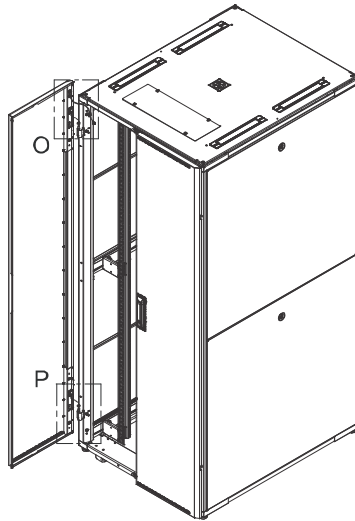

DETAIL P

Hardware	Qty.
Torx head screw M6 x 12	6
Hinge bush	4
Screw torx taper M6 x 12	4

Set Torque 55-60 in.lbs

Time required this step : 2 mins.



SIDE CHANNEL COVER ASSEMBLY

1. Install Side Channel Cover between Middle Side Brace and PMA.



Note : Three versions of side channel covers are available for cable management.

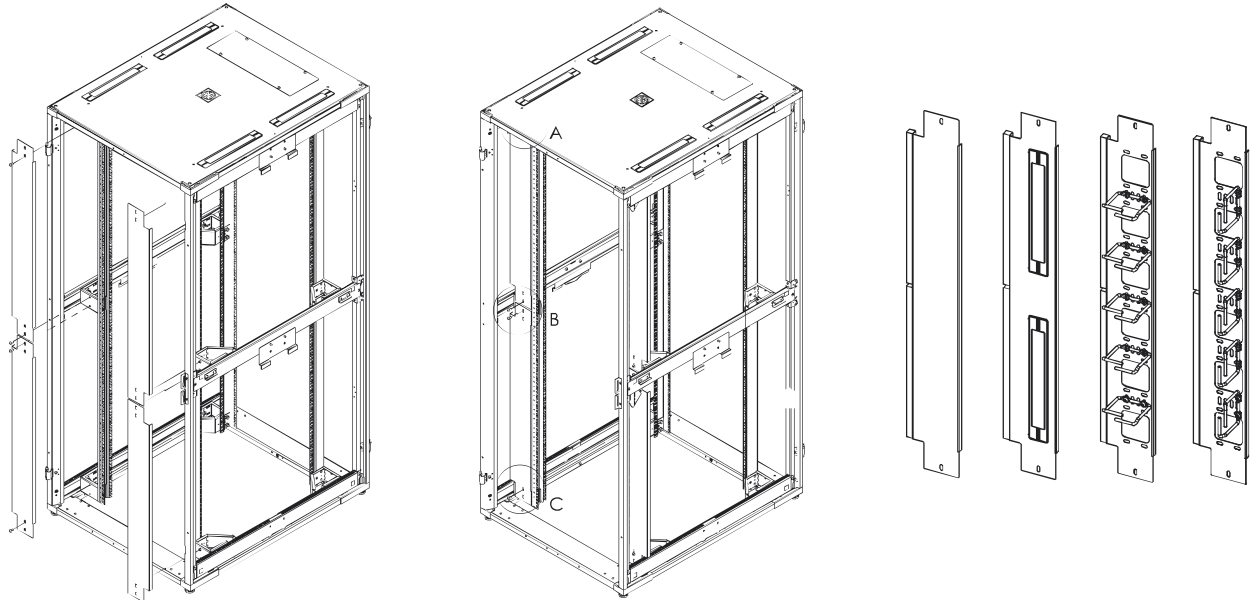

2. Top piece uses bottom hole position to fix with top PMA adapter (See detail A). Use bottom hole position to fix with middle PMA adapter (See detail B).

3. Bottom piece uses top hole position to fix with middle PMA adapter (See detail B). Use top hole position to fix with bottom PMA adapter (See detail C).

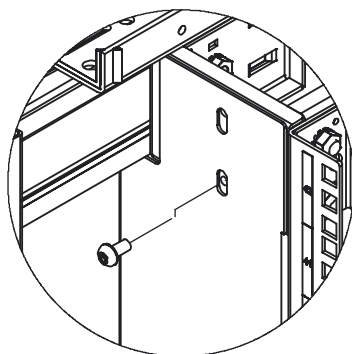

DETAIL A

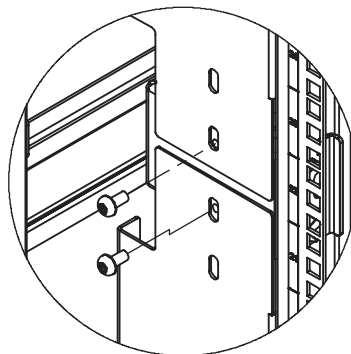

DETAIL B

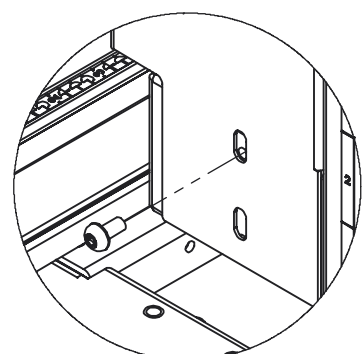

DETAIL C

Hardware	Qty.
Torx head screw M6 x 12	8
Side Channel cover	4



PDU/VERTICAL CABLE RAIL ASSEMBLY

1. PDU/Vertical Cable Rail normally installs at the rear of cabinet.
2. Install Vertical Cable Rail with Post Mounting Bracket and Middle Side Brace at the rear of cabinet. See steps 1 and 2 in detail T below.

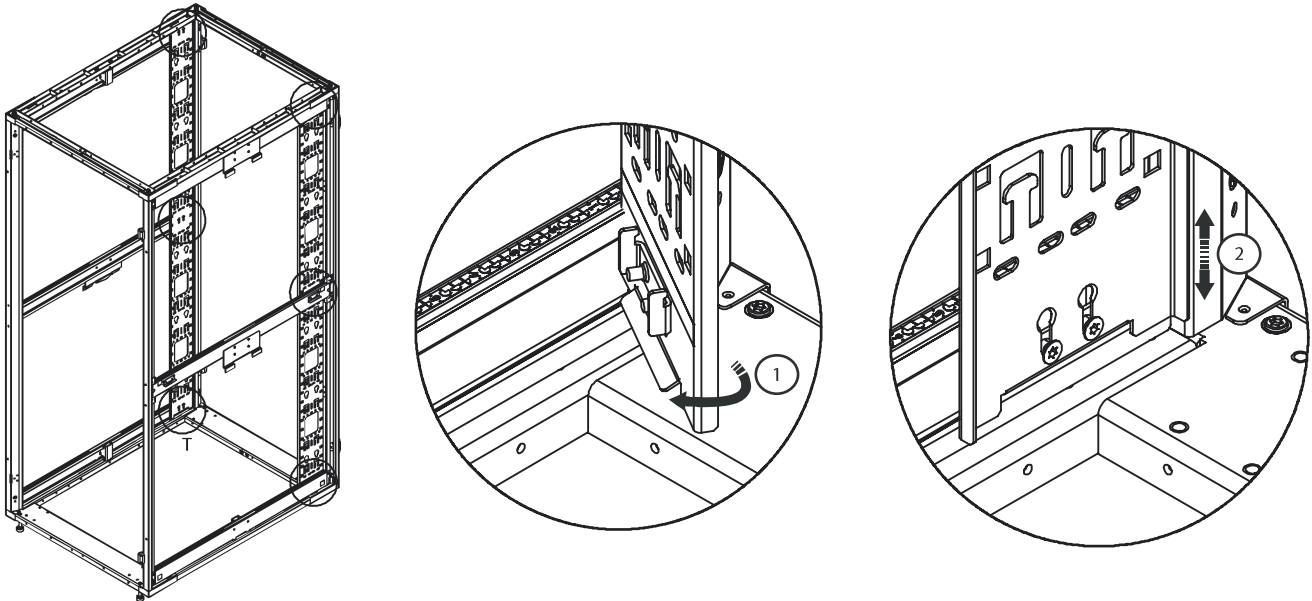

DETAIL T

3. Lift up screws to lock the position and set torque at 50-60 in.lbs
See steps 3 and 4 in detail T below.

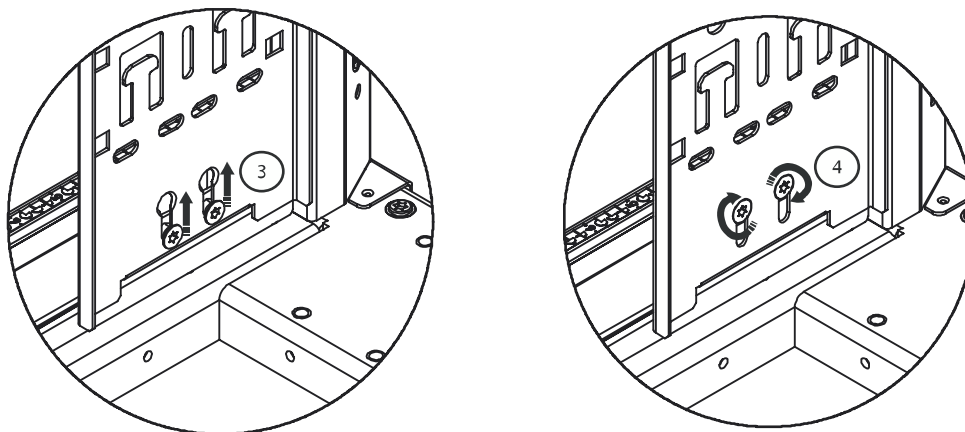

Set Torque 55-60 lbs.in

DETAIL T



Overall Dimensions of Assembled Arion V2 (standard Top version shown)

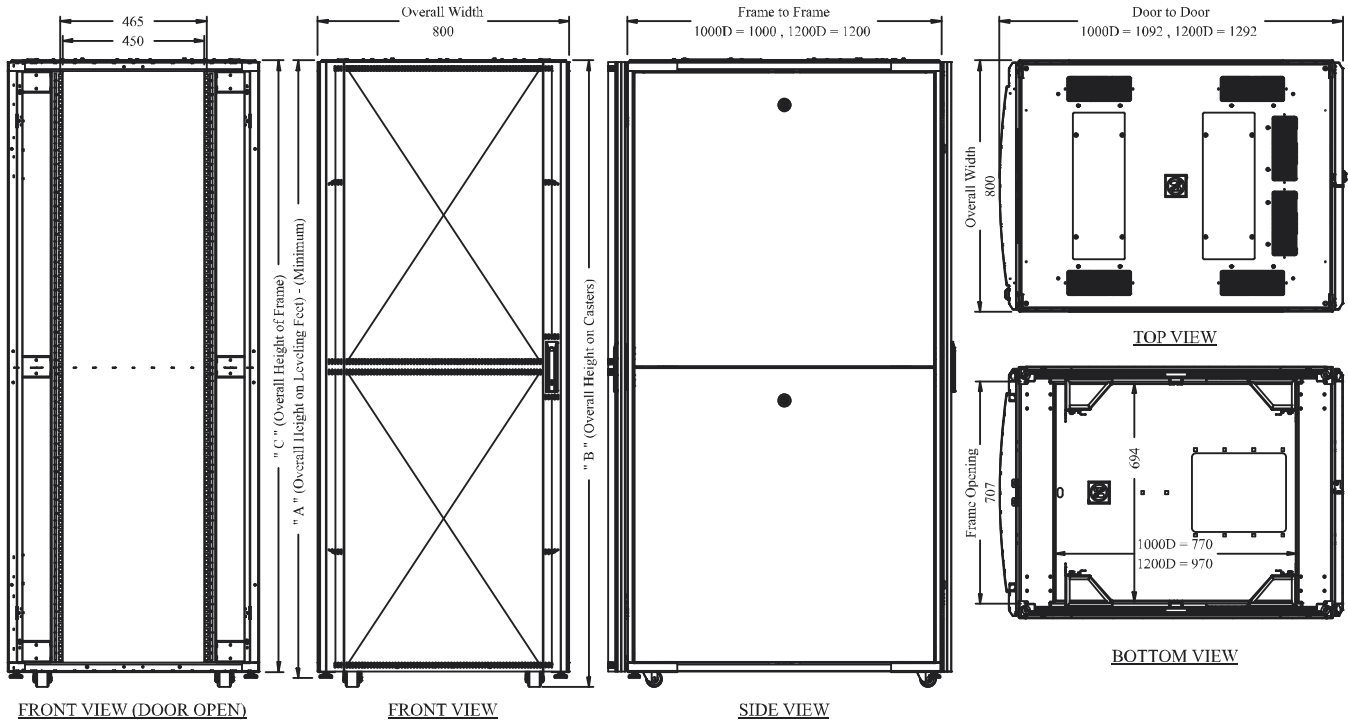

DIMENSIONS (UNIT : MM)			
UNIT HEIGHT	DIM. "A"	DIM. "B"	DIM. "C"
42U	1966	1994	1946
45U	2099	2127	2079
47U	2188	2216	2168

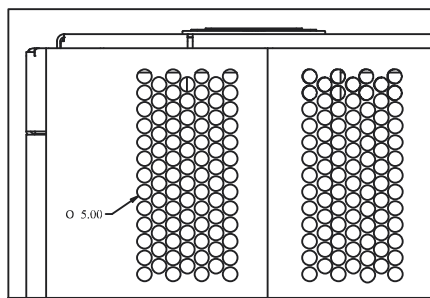

High density perforation on our doors provide open area for air flow exceeding equipment makers requirements. Our perforation patterns provide 71% open area, but the total open area is a better indicator of air flow.

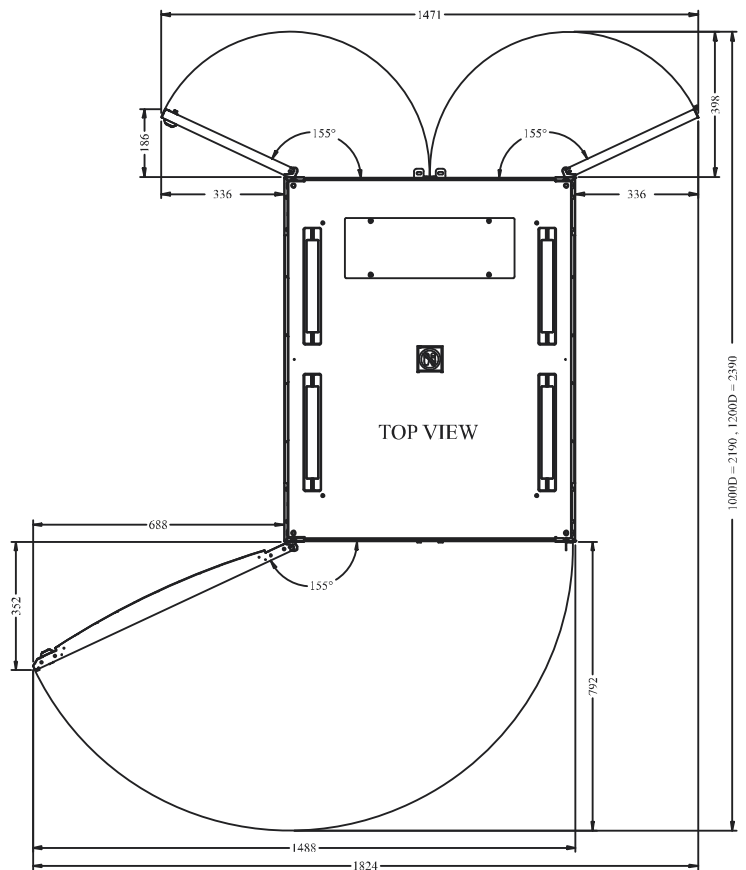



www.chevalgrp.com