



Paperless recorder SUP-5000C

Headquarters

5th floor, Building 4, Singapore Hangzhou Science Technology Park, No. 6 street,
Hangzhou Economic Development Area, Hangzhou 310018, China

Singapore

2 Venture Drive #11-30 Vision Exchange Singapore

Philippines

Majestic Subdivision, Lot 1, 1800 Rainbow St, Marikina, 1811 Metro Manila, Philippines

✉ info@supmea.com

🌐 www.supmea.com

Supmea Automation Co., Ltd.

Contents

I. Overview.....	1
II. Technical parameters.....	1
III. Precautions for use and installation.....	2
3.1 Precautions for use.....	2
3.1.1 Precautions for use of this instrument.....	2
3.1.2 Precautions for using external storage media.....	3
3.2 Installation of instrument.....	3
3.2.1 Sites of installation.....	3
3.2.2 Methods for installation.....	4
IV. Functions and operation of the instrument.....	5
4.1 Switching of running screens.....	6
4.2 Status display.....	6
4.3 Real-time curve screen.....	6
4.4 Bar chart screen.....	8
4.5 Digital display screen.....	9
4.6 Historical curve screen.....	10
4.7 Alarming list screen.....	11
4.8 File list screen.....	12
4.9 Printing screen (In case there is the printing function, the screen is available).....	13
4.10 Backup screen (In case there is the backup function, the screen is available).....	15
4.11 Power-off screen.....	17
4.12 Configuration screen.....	18
4.12.1 System configuration.....	18
4.12.2 Record configuration.....	19
4.12.3 Display configuration.....	21
4.12.4 Input configuration.....	22
4.12.5 Analogue output.....	31
4.12.6 Functions list.....	32
V. Communication.....	32
VI. Parts for the instrument.....	38

I. Overview

Color paperless recorder has 12-channel universal input (configurable selective input: standard voltage, standard current, thermocouple, thermal resistance, millivolt, etc.). It can be equipped with 12-channel alarming output or 6-channel transmitted output of analog quantity, RS485 communication interface, Ethernet interface, micro printer interface and USB interface, SD card socket; It can provide power distribution for sensor; It has powerful display function, real-time curve display, historical curve recall, and bar chart display, alarming list display, etc. The characteristics of humanized appearance design, perfect function, reliable hardware quality and exquisite manufacturing technology render the instrument a higher performance-price ratio.

II. Technical parameters

Measurement inputs	
Input signals	<p>Current: 0~20mA, 0~10mA, 4~20mA, 0~10mA radiation, 4~20mA radiation</p> <p>Voltage: 0~5V, 1~5V, 0~5V radiation, 1~5V radiation, 0~100mV, ±20mV, ±100mV</p> <p>Thermal resistance: Pt100, Cu50, Cu53, Cu100, BA1, BA2</p> <p>Linear resistance: 0~400Ω</p> <p>Thermal resistance: B, S, K, E, T, J, R, N, F2, Wre3-25, Wre5-26</p>
Output	
Output signals	<p>Analog output: 4~20mA (Load resistance≤380Ω), 0~20mA (Load resistance≤380Ω), 0~10mA (Load resistance≤760Ω), 1~5V (Load resistance≥250KΩ), 0~5V (Load resistance≥250KΩ), 0~10V (Load resistance≥10KΩ)</p> <p>Alarming output: Relay normally open contact output, the contact's capacity 1A/250VAC (resistive load).</p> <p>(! Note: when the load exceeds the contact's capacity of the relay, please do not carry with load directly)</p> <p>Feed output: DC24V±10%, Load current≤200mA</p> <p>Communication output: RS485/RS232 communication interface, baud rate of 1200-57600 bps can be set, using the standard MODBUS RTU communication protocol, RS485 communication distance can reach 1km; RS232 communication distance can reach 15m; The EtherNet communication interface, the communication rate is 10M.</p>
Comprehensive parameters	
Accuracy of	0.2%FS±1d

measurement	
Display refresh cycle	1 second
Setting mode	The panel touch button is set; The parameter's setting value is locked in password; The setting value is cut off for permanent storage.
Display mode	With 7 inch 800*480 dot matrix wide screen and TFT high brightness color graphics LCD display, LED backlight, clear screen, wide viewing angle. The display content can be composed of Chinese characters, numbers, process curves, bar charts, etc. Through panel keys, the screen can be paged up and down, the search of historical data before and after, the change of curve time scale, etc.
Data backup	Support Flash and SD card for data backup and transfer, with the maximum capacity of 8GB, supporting FAT, FAT32 format.
Memory capacity	The memory capacity of internal Flash: 64M Byte
Recording interval	1, 2, 4, 6, 15, 30, 60, 120, 240 seconds ,totally 9 gears, are available for selection.
Memory length (UPS Continuous recording)	24 days (while the interval is 1 second)—5825 days (while the interval is 240 seconds) Formula: Recording duration(day)= $\frac{64 \times 1024 \times 1024 \times \text{Recording interval(s)}}{\text{No of channels} \times 2 \times 24 \times 3600}$ (! Note: Calculation of the number of channels: The program divides the number of channels into 5 gears ,that is, 4, 8, 16. When the number of instrumentation channels falls between the two gears, the larger number is used as the number of channels. For example, the number of instrument channels is 12-channel, and the number of channels is calculated with 16 in the formula.
Operating environment	Ambient temperature:-10~50°C Relative humidity: 10 ~ 90%RH (RH); avoid strong corrosive gases. (! Note: In case the site is in bad condition, special instructions must be made when ordering.
Working power supply	AC85 to 264V (switching power supply), 50/60Hz
Power Consumption	≤15W

III. Precautions for use and installation

3.1 Precautions for use

3.1.1 Precautions for use of this instrument

- There are more plastic parts for this instrument. When you clean it, please use a dry soft

cloth to wipe it. Benzene and banana water etc. should not be used for cleaning, which it may lead to discoloration or deformation.

- Please do not make the live parts approach the signal terminal, which may cause fault.

- Please do not impact this instrument.

- If you confirm that smoke, undesirable odor, abnormal noise and other abnormal situations occur from the instrument, please cut off the power supply immediately and contact the supplier or our company in time.

- In order to ensure the normal work of instrument measurement, please energize the thermal machine for 30 minutes prior to using the instrument.

3.1.2 Precautions for using external storage media

- Storage media is a sophisticated product. Please use it carefully.

- In addition to inserting and removing storage media, please close the operation cover when running. Storage media and USB interface should reduce contact with dust for protection.

- Pay attention to electrostatic protection when using Flash and SD card.

- Recommend the use of our products.

- When using storage media at high temperature (about above 40°C), please insert the storage media when saving the data. After the data is saved, remove it and keep it. Do not keep inserting it into the instrument for a long time.

- Before you switch on or switch off the power, please remove the storage media.

- For general precautions for use of storage media, please refer to the instructions carried for use of the storage media.

3.2 Installation of instrument

3.2.1 Sites of installation

Please install the following sites:

- Installation disk

This instrument is disk-installed.

- Place for installation

It should be installed indoors, where it can avoid rain and direct sun.

- Well ventilated places.

In order to prevent the temperature rise in the internal of this instrument, please install it in a well ventilated place.

- Places with less mechanical vibration.

Please choose a place with less mechanical vibration.

- Flat place

When installing this instrument, do not incline to the left or right, as flat as possible, with an allowable maximum backward inclination of 30°).

★Move the instrument from the place with low temperature and humidity to the place with

high temperature and humidity. If the temperature changes significantly, it will sometimes result in condensation of moisture. When the thermocouple is input, the measurement error will occur. At this time, please adapt to the surrounding environment for 1 hour or more and then continue using.

★If it is used at high temperature for a long time, the life of LCD will be reduced (The quality of screens is reduced, etc.). Please try not to use it at high temperature (about above 40°C).

Please do not install it in the following places:

- The place where is exposed directly to the sun and the vicinity of the hot appliances.

Please try hard to choose the place with a small change of the temperature and near the normal temperature (23°C). If the instrument is installed in the place where is exposed directly to the sun or near the hot appliances, it will have a bad impact on the interior of the instrument.

- Places where there are more oil smoke, steam, moisture, dust, corrosive gas and so on.

Oil fume, steam, moisture, dust, corrosive gas and so on will have bad effects on the instrument.

- Near the source of electromagnetism

Please do not approach magnetic appliances or magnets near this instrument. If the instrument is installed near the source of strong electromagnetic field, the display error will be brought about by the influence of magnetic field.

In order to avoid abnormal operation of the instrument, it is necessary to keep a distance of more than 20 cm with the instrument while using the radio frequency generator on site.

- Places that are not easy to see the screens.

The displayed part of this instrument is a 7-inch TFT true-color LCD. If it looks extremely off-centre, it will be difficult to see the display. So please try to fix it in a place where the observer can view it right ahead.

3.2.2 Methods for installation

- Dimensions for installation(Unit: mm)

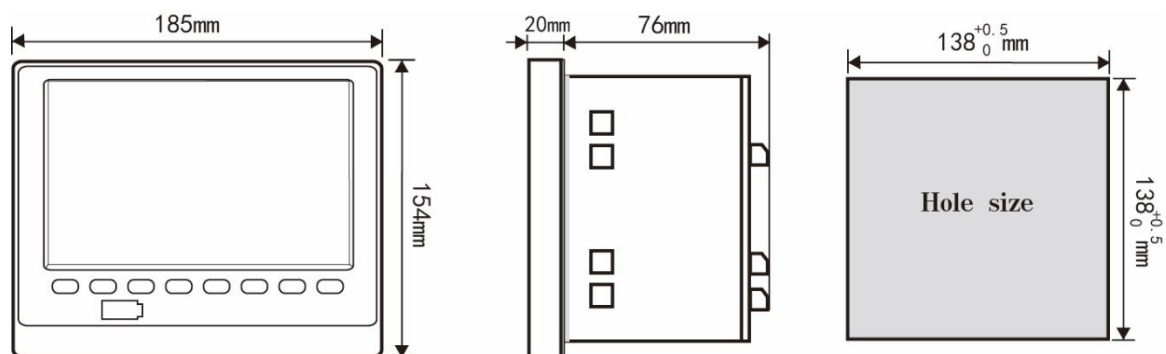

●Installation of instruments

(1) Methods for installation

A. Put in the instrument from the front of the dashboard.

B. Use the mounting support carried with the instrument, as shown in the right figure.

▲Fixed four mounting brackets on both sides of the instrument .

(2) Installation figure is shown as the right figure.

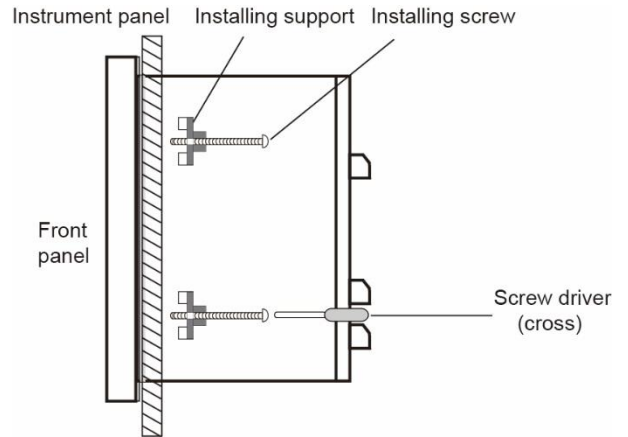

●Wiring diagram for instrument

Terminal diagram of instrument tail

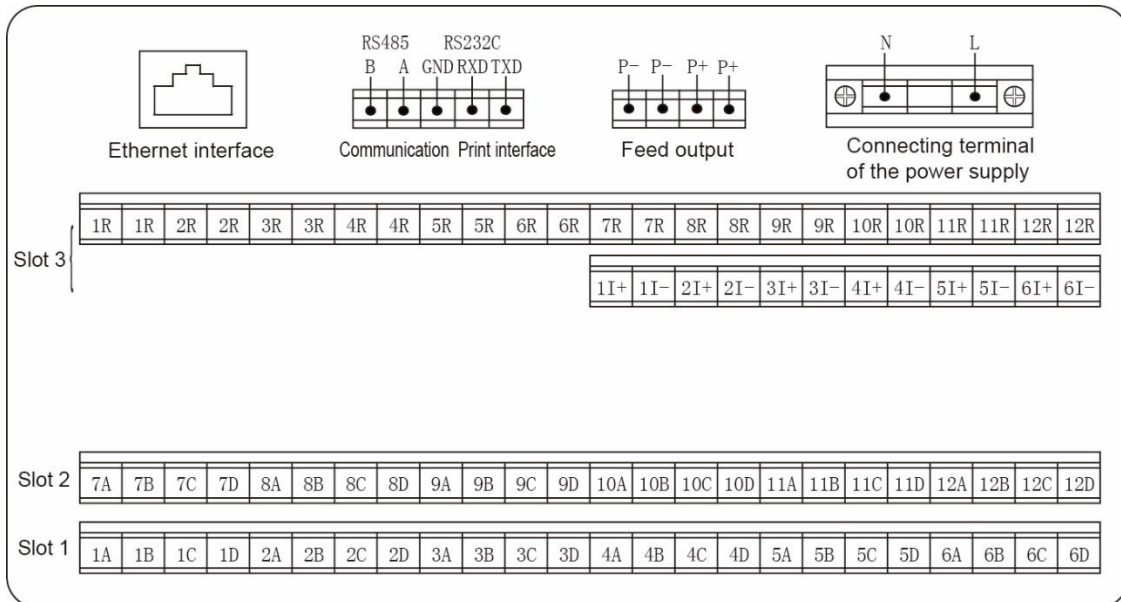

Wiring illustration

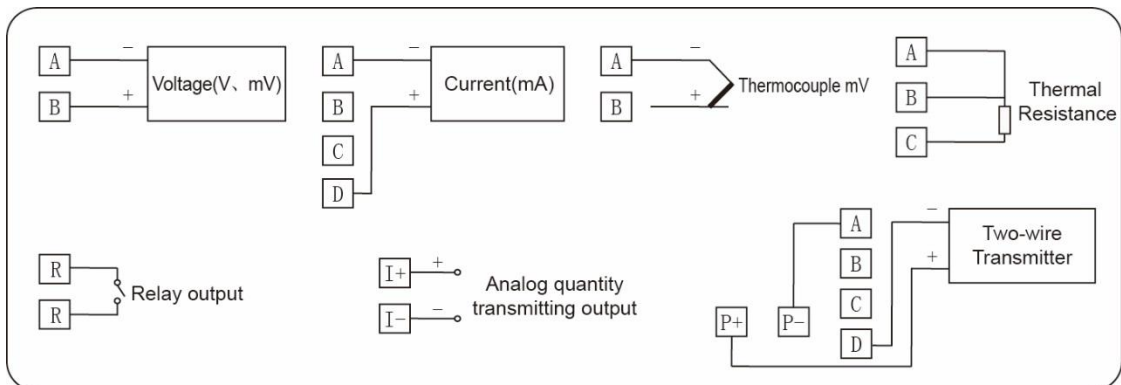

IV. Functions and operation of the instrument

The color paperless recorder has multiple operation display screens and configuration screens with the clear display, large amount of information and convenient configuration. Users can

operate the instrument conveniently without professional training. After the instrument is connected to the power supply, the initial screen of the system is displayed, the initialization system is completed, and thus the real-time curve screen is entered. The following will introduce each operation display screen and each configuration screen respectively.

4.1 Switching of running screens

The running screens consist of real-time curve screen, bar chart screen, digital display screen, historical curve screen, alarming list, file list, printing screen, backup screen, and power-off recording screen and configuration parameters.

The Switch key is used to switch between the screens.

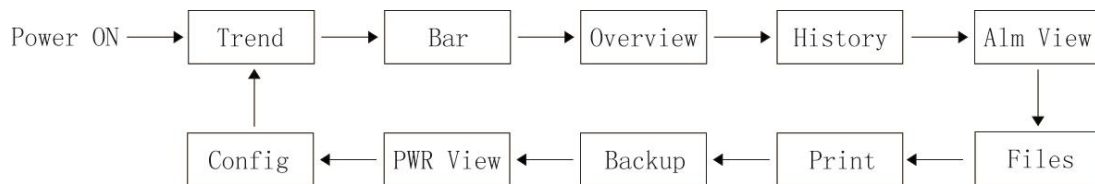

4.2 Status display

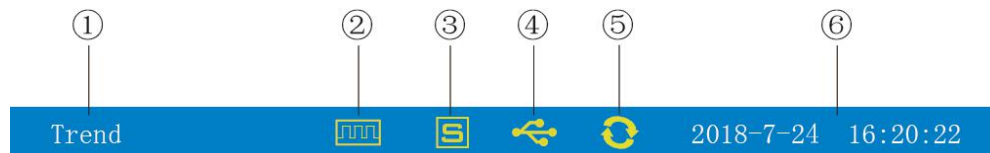

①: Display the name of each running screen.

②: File record mark

Display available: It indicates the file is circularly recording.

Display available with arrow mark: It indicates the file is not circular recording.

Display not available: It indicates the file stops recording.

③: SD card mark

Display available: It indicates SD card is connected.

Display not available: It indicates no SD card is connected.

④: Flash mark

Display available: It indicates flash is connected with instrument.

Display not available: It indicates no flash is connected with instrument.

⑤: Circular display mark

Display available: It indicates circular display for each group.

Display not available: It indicates the fixed screen, no circular display.

⑥: Display the date and time of the operation of the instrument.

4.3 Real-time curve screen

According to the combination of curves, the real-time curves and data of 6-channel are displayed simultaneously (the accuracy of the curves is 0.5%±1 character).

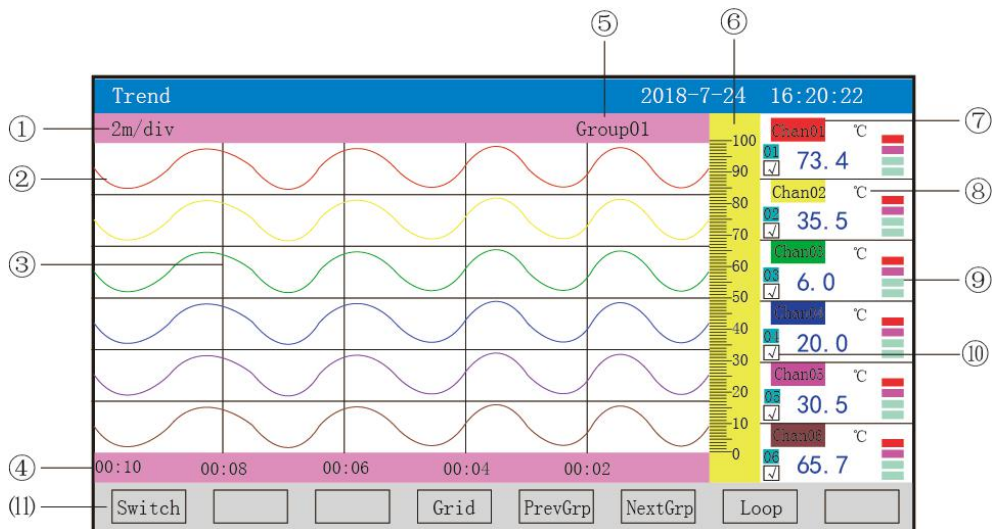

①: Time scale: The duration of time expressed in each grid, and the time scale is related to the recording interval. Refer to the table below:

Recording interval	1S	2 S	4 S	6 S	15 S	30 S	1min	2 min	4 min
Time scale	2min/grid	4min/grid	8min/grid	12min/grid	30min/grid	1h/grid	2h/grid	4h/grid	8h/grid
	4min/grid	8min/grid	16min/grid	24min/grid	1h/grid	2h/grid	4h/grid	8h/grid	16h/grid
	8min/grid	16min/grid	32min/grid	48min/grid	2h/grid	4h/grid	8h/grid	16h/grid	32h/grid
	16min/grid	32min/grid	64min/grid	96min/grid	4h/grid	8h/grid	16h/grid	32h/grid	64h/grid

②: Data curve: Maximum 6 curves can be displayed on the same screen simultaneously(there are 6 kinds of curve colors, which can be set by display configuration).

③: Grid: Convenient for users to estimate time and data value.

④: The time represented by the current grid.

⑤: Curve combination: Display the name of the current curve combination (each curve combination can include six curves, users can put related channels in a curve combination according to their own needs, so as to facilitate data comparison between channel groups.)

⑥:Ruler: The ruler that displays the percentage of curves.

⑦: The name of the channel .It can be set, and the background color is the same as that of the corresponding curve. (As for the setup method, please refer to Section 4.12.4.1: Input Method of Channel's Bit Number).

⑧: Unit: Display the data unit of the channel and set it up. (As for the setup method, please refer to Section "4.12.4.2 Input Method of Channel's Unit ").

⑨: Over-limit alarming instructions: From top to bottom, each block in turn is the high high limit, high limit, low limit and low low limit of the over-limit alarming signs. Gray indicates no

alarming function , green indicates no alarming, red/pink indicates alarming.

⑩: The display / hidden marks of curves: "√" indicates display of curve, if not, hide the curve.

(11): Operation keys:

Press the "Switch" key to switch to other display screens.

Press the "Time scale" key to switch the time scale.

Press the "Preceding group" key to see the curve combinations of the previous group

Press the "Latter group" key to see the curve combination of the latter group.

Press the "Cycle" key to display the cycle icon "🔄" on the screen, and automatically switch to the next group of curve combinations according to the cycle interval set in the display configuration.

4.4 Bar chart screen

Display 8-channel data and percentage bar chart simultaneously.

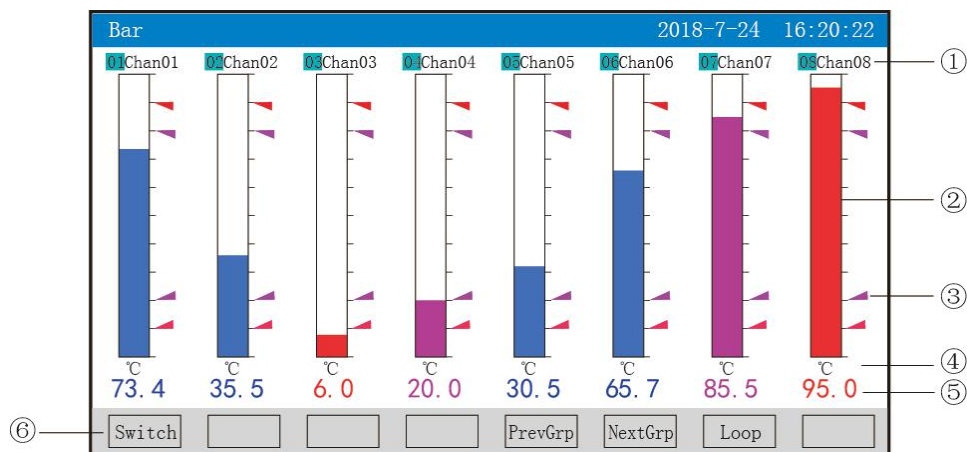

①: The name of the channel: It indicates the bit number of the engineering corresponding to the display channel can be set. (As for the setup method, please refer to Section 4.12.4.1 Input method of channel's bit number).

②: Bar chart: The length of the bar chart's ruler is 10 grids, and the filling length of the color blocks represents the percentage of the measured value in the measurement range. Blue indicates that the measured value is not in the alarming state; red indicates that the measured value is in the high or low alarming state, pink indicates that the measured value is in the high high or high low alarming state.

③: Alarming location mark: The alarming position marks for high high limit, high limit, low limit, low low limit.

④: Unit: It displays the data unit of the channel and set it. (As for the setting method, please refer to Section 4.12.4.2 Input Method of Channel's Unit).

⑤: Engineering data: They are the current engineering data of the channel, blue indicates that the measured value does not meet the output of alarming; red indicates that the measured value meets the alarming output.

⑥ Operation keys:

Press the " Switch" key to switch to other display screens.

Press the "Preceding group" key to see the bar charts combinations of the previous group

Press the "Latter group" key to see the bar charts combination of the latter group.

Press the "Cycle" key to display the cycle icon "🔄" on the screen, and automatically switch to the next group of bar charts combinations according to the cycle interval set in the display configuration.

4.5 Digital display screen

It also displays real-time data and alarming state of multiple channels.

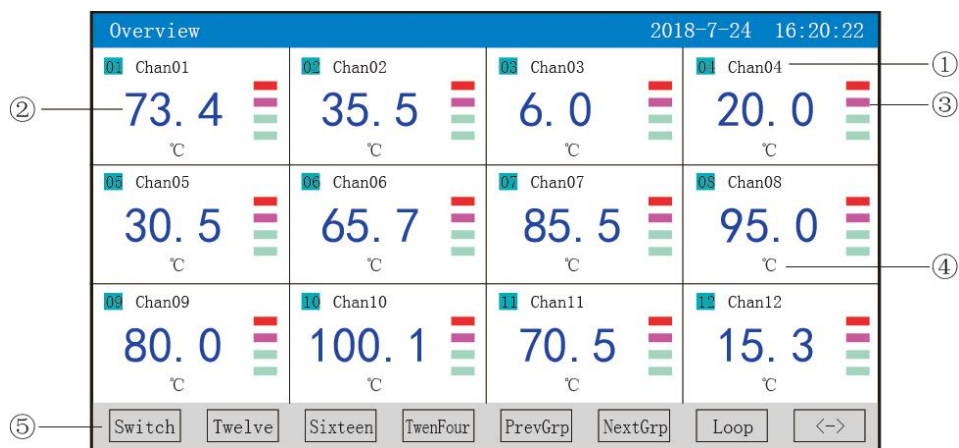

①: The name of the channel: It indicates the bit number of the engineering corresponding to the display channel, which can be set. (As for the setting method, please refer to Section 4.12.4.1 Input Method of Channel's Bit Number).

②: Engineering data: They are the current engineering data of the channel.

③: Unit: It displays the data unit of the channel and set it. Please refer to Section 4.12.4.2 Input Method of Channel's Unit.

④: Over-limit alarming instructions: From top to bottom, each block in turn is the high high limit, high limit, low limit and low low limit of the over-limit alarming signs. Gray indicates no function of alarming, green indicates no alarming, red/pink indicates alarming.

⑤: Operation keys:

Press the " Switch" key to switch to other display screens.

Press the " <-> " key to switch the number of the channels for display screen, there are Channel-2, 4, 6, 12 display.

Press the "Channel-2" key to display the bit number of channels, data of engineering quantity, alarming state and engineering unit of Channel-2 simultaneously.

Press the "Channel-4" key to display the bit number of channels, data of engineering quantity, alarming state and engineering unit of "Channel-4" simultaneously.

Press the "Channel-6" key to display the bit number of channels, data of engineering quantity, alarming state and engineering unit of "Channel-6" simultaneously.

Press the "Channel-12" key to display the bit number of channels, data of engineering quantity, alarming state and engineering unit of "Channel-12" simultaneously.

Press the "Preceding group" key to see the digital display combinations of the previous group

Press the "Latter group" key to see the digital display combination of the latter group.

Press the "Cycle" key to display the cycle icon "🔄" on the screen, and automatically switch to the next group of the digital display combinations according to the cycle interval set in the display configuration.

4.6 Historical curve screen

According to the setting of curves combination, the curves of 6 channels' historical data are displayed simultaneously (the accuracy of the curves is 0.5%±1 character).

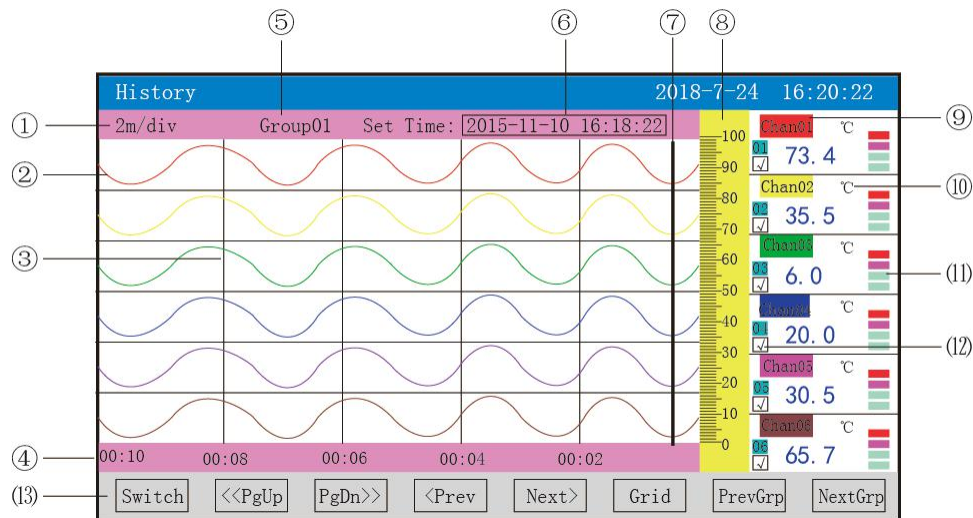

①: Time scale: The duration of time expressed in each grid, and the time scale is related to the recording interval. For details, see the description in 4.3 Real-time Curve Screen.

②: Data curve: Maximum 6 curves can be displayed on the same screen at the same time (There are 6 kinds of curve colors, which can be set by display configuration).

③: Grid: convenient for users to estimate time and data value.

④: The time represented by the current grid.

⑤: Curve combination: It displays the name of the current curve combination (Each curve combination can include 6 curves, users can put related channels in a curve combination according to their own needs, so as to facilitate data comparison between channel groups.)

⑥: Recalling time: "year -month -day time -minute-second".

⑦: Ruler: The ruler that displays the percentage of curves.

⑧: The name of the channel .It can be set, and the background color is the same as that of the corresponding curve. (As for the setting method, please refer to Section 4.12.4.1: Input Method of Channel's Bit Number).

⑨: Unit: Display the data unit of the channel and set it. As for the setting method, please refer to Section 4.12.4.2 Input Method of Channel's Unit.

⑩: Over-limit alarming instructions: From top to bottom, each block in turn is the high high

limit, high limit, low limit and low low limit of the over-limit alarming signs. Gray indicates no function of alarming, green indicates no alarming, red/pink indicates alarming.

(11): The display / hidden marks of curves: "√" indicates display of curve, if not, hide the curve.

(12): Operation keys:

Press the " Switch" key to switch to other display screens.

Press the " < < Forward" key to recall the data based on the current recalling time from forward.

Press the " > > Backward" key to recall the data based on the current recalling time from backward.

Press the "Time scale" key to switch the time scale.

Press the "Preceding group" key to see the curve combinations of the previous group

Press the "Latter group" key to see the curve combination of the latter group.

Press the "Time" to modify the recalling time: "Year -Month -Day Hour - Minute-Second".

4.7 Alarming list screen

It displays the alarming information of channels and output status of the relay, with maximum 100 pieces of the alarming information being saved, which after the limit is up to, the new alarming record will cover the earliest alarming record.

Alm View							2018-7-24 16:20:22	
No.	Chan	Name	Alarm Time		Clear Time		Type	
01	Chan01	Chan01	2015-11-10	16:00:22	2015-11-10	16:00:22	L	
02	Chan01	Chan01	2015-11-10	16:01:22	2015-11-10	16:01:22	L	
03	Chan01	Chan01	2015-11-10	16:02:22	2015-11-10	16:02:22	H	
04	Chan01	Chan01	2015-11-10	16:03:22	2015-11-10	16:03:22	L	
05	Chan01	Chan01	2015-11-10	16:04:22	2015-11-10	16:04:22	L	
06	Chan01	Chan01	2015-11-10	16:05:22	2015-11-10	16:05:22	H	
07	Chan01	Chan01	2015-11-10	16:06:22	2015-11-10	16:06:22	L	
08	Chan01	Chan01	2015-11-10	16:07:22	2015-11-10	16:07:22	LL	
09	Chan01	Chan01	2015-11-10	16:08:22	2015-11-10	16:08:22	L	
10	Chan01	Chan01	2015-11-10	16:09:22	Power off Clear		L	

Below the table is a row of indicator lights labeled 01R to 12R. At the bottom is a control panel with buttons: Switch, Up, Down, PgUp, PgDn, Home, End, and <->.

①: Serial number: The serial number of the alarming is generated and arranged in a time manner. The closer the occurrence time is, the larger the Serial number is.

②: Channel: Generate the input channel number of the alarming.

③: Bit number: Generate the bit number corresponding to the input channel of the alarming.

④: Alarming time: starting time of the alarming.

⑤: Cancellation of alarming time: stopping of alarming time.

⑥: Alarming type: The alarming symbol of high high limit is "HH", the alarming symbol of high limit is "H", the alarming symbol of low limit is "L", the alarming symbol of low low limit is "LL".

⑦: The current relay state, from left to right, they symbolizes in turn the current state of 1-12 limit relays, green indicates that the relay contacts are disconnected, red indicates that the relay contacts are closed.

⑧: Operation keys:

Press the "Switch" key to switch to other display screens.

Press the "Up shift" key to move upwards to view the alarming list.

Press "Down shift" key to move downwards to view the alarming list.

Press the "Page Up" key to page up the page to view the alarming list.

Press the "Page Down" key to page down to view the alarming list.

Note: this list displays 13 pieces of alarming records on one screen.

4.8 File list screen

It displays the file storage information and file storage status, with maximum 100 pieces of the alarming information being saved, which after the limit is up to, the new alarming records will cover the earliest alarming records.

The screenshot shows a 'File View' screen with a table of alarming records. The table has columns for No., Start Time, End Time, Int, Cond, and Status. The records are numbered 001 to 007. Below the table, there is a status bar showing 'Files: 7 Record Time: 00d-00h:3m:50s' and a progress indicator at 6%. At the bottom, there is a control panel with buttons for Switch, Up, Down, PgUp, PgDn, Curve, and Backup. Circled numbers 1 through 9 point to various elements in the screenshot.

No.	Start Time	End Time	Int	Cond	Status
007	2018-7-24 15:30:40	2018-7-24 15:31:00	1S	Pwr	Recording
006	2018-7-24 15:30:10	2018-7-24 15:30:30	1S	Pwr	Poff stop
005	2018-7-24 15:29:40	2018-7-24 15:30:00	1S	Pwr	Poff stop
004	2018-7-24 15:29:10	2018-7-24 15:29:30	1S	Pwr	Poff stop
003	2018-7-24 15:28:40	2018-7-24 15:29:00	1S	Pwr	Poff stop
002	2018-7-24 15:28:10	2018-7-24 15:28:30	1S	Pwr	Poff stop
001	2018-7-24 15:28:10	2018-7-24 15:28:30	1S	Pwr	Man stop

①: Serial number: The serial number of the alarming is generated and arranged in a time manner. The closer the occurrence time is, the larger the Serial number is.

②: Starting time: starting time of data record in file.

③: End time: The end time of the data record in the file.

④: Time Interval: The time interval between the records and display the record interval set in the record configuration.

⑤: Record trigger: The triggering condition of the file record, and display triggering condition set in record configuration.

⑥: Status: Display the current status of the file record. The file's status is as follows:

Recording: The file is recording the data.

Manual stopping: The file ends the record due to modification of the configuration data.

Stop due to power off: The file ends the recording due to the power off of the instrument.

alarming stopping: The file ends the record due to the cancellation of alarming.

Timing stopping: The file ends the record while coming to the set time.

⑦: Record the total duration: Calculate the total duration of file records.

⑧: The progress bars of the file's storage capacity (Note: The record mode in the record configuration appears when it is not circular).

⑨: Operation keys:

Press the "Switch" key to switch to other display screens.

Press the "Up shift" key to move upwards the arrow to view the file list.

Press "Down shift" key to move downwards the arrow to view the file list.

Press the "Page Up" key to page up to view the file list.

Press the "Page Down" key to page down to view the file list.

Press the "Curve" key to jump to the historical curve screen the arrow is towards to view the historical curve data, and press the "Backspace" key in the historical curve screen to back to the file list screen.

Press the "Backup" key to jump to the backup screen; you can back up a single historical file or all historical files. For the specific operations ,you can view the 4.10 Backup Screen and press the "Backspace" key to back to the file list screen.

Note: This list displays 13 pieces of alarming records on one screen.

4.9 Printing screen (In case there is the printing function, the screen is available)

The paperless recorder connects the mini printer through the RS-232 printing interface to print the historical data and curves. The baud rate of the printer is "4800", data bits: 8, parity: none.

Label	Value
① Content	RealData
② Type	Data
③ File No.	001
④ Start Time	2018-7-24 16:10:22
⑤ End Time	2018-7-24 16:20:22
⑥ Channel	Chan01
⑦ Interval	001

⑧ Control buttons: Switch, Up, Down, Print, Enter

①: Printing content: The real-time data and historical data are optional. When choosing real-time data, press the "Print" key to print directly. When choosing historical data, the following content can be changed.

②: Printing mode: Data reports and historical curve are optional.

③: The serial number of files: The serial number of the record file.

④: Starting time: Print the starting time of the data segment.

⑤: End time: Print the end time of the data segments.

⑥: Printing channel: Select the channel to print.

⑦: Printing time interval: Select the time interval between data printings, the unit is the set printing interval \times recording interval (only valid for data printing).

⑧: Operation keys:

Press the "Switch" key to switch to other display screens.

Press the "Up shift" key to move upwards the cursor, then press the "Enter" key to modify the cursor, and then press the "Enter" key to confirm exit after modification.

Press the "Down shift" key to move downward the cursor, then press the "Enter" key to modify the cursor, and then press the "Enter" key to confirm exit after modification.

Press the "Print" key to start printing.

Press "Delete" key to delete printing.

Connection Schematic diagram between the instrument and serial printer:



A: Manual printing

Press the "Print" key to start printing the progress bar, and the instrument starts printing data or curves.

Record format of curve printing:

Starting time: 18-07-24 15:31:40

End time: 18-07-24 15:34:20

Printing time interval: 1S

Channel 01: unit: °C

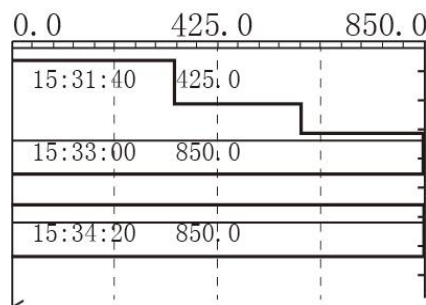

The data printing format is as follows:

Starting time: 18-07-24 15:31:40

End time: 18-07-24 15:32:00

Printing time interval: 1S

Channel-01: unit: °C

Time	Data
18-07-24 15:31:40	850 - -- measurement value of starting time
18-07-24 15:31:41	850
18-07-24 15:31:42	850
...	
18-07-24 15:31:58	425
18-07-24 15:31:59	425
18-07-24 15:32:00	425 - -- measurement value of end time

B. Timing printing

The time interval and starting time for the timing printing are set in the system configuration. When the system time reaches the set interval time, the instrument will automatically control the printer for timing printing.

Timing printing format:

```

-----
Printing time: 18-07-24 14:30:02 ----- date and time
Channel 01:100.0°C ----- measurement value of No. 01 channel
Channel 02:100.0°C ----- measurement value of No.02 channel
.....
Channel 11:100.0°C ----- measurement value of No.11 channel
Channel 12:100.0°C ----- measurement value of No. 12 channel
-----

```

Note: The manual printing can print data and curves, while the timing printing can only print data.

4.10 Backup screen (In case there is the backup function, the screen is available)

The paperless recorder used flash or SD card to back up and transfer the recorded data in the instrument. The USB interface is on the front panel of the instrument, and the SD card interface is on the left side of the instrument. As long as the operation cover is opened, the flash or SD card can be inserted into for the operation of data backup.

SD card has automatic backup function: After inserting SD card into the driver, the instrument will automatically back up the recorded historical data to SD card at 0 o'clock every day; When the recording is stopped or the triggering condition set by the user is reached, the instrument will automatically back up the historical data to SD card.

Automatically back up file's storage directory:

1. File's storage directory backed up at 0:00 a day: TIMEAUTO (folder's name)/instrument date (year/month/day)/instrument time (hour/minute).

2. Record the file's storage directory for stopping backup: RECAUTO (folder's

name)/instrument date (year/month/day)/instrument time (hour/minute).

In this operation screen, the user can back up the historical data of all channels recorded in the instrument to the flash or SD card, and input the backup data into the computer to reproduce, analyze and print the data through DTM, the software of the upper computer.

Label	Field/Key	Value
①	Backup	All HisFile
②	File No.	001
③	Start Time	2018-7-24 16:10:22
④	End Time	2018-7-24 16:20:22
⑤	Fold Name	DAT0001.NHD
⑥	Operation keys	Switch, Up, Down, Backup, Enter

①: Backup content: All files, single historical file, alarming record, power-off record or file list are optional.

②: The serial number of files: The serial number of the record file.

③: Starting time: The starting time of the backup data segment.

④: End time: The end time of the backup data segment.

(Note: The starting time and end time are automatically generated by the instrument according to the currently selected serial number of files. The time box can not be modified when it is in shadow display. The time box can be modified when it is not in shadow display. If the modified time exceeds the range of the actual starting and end time of the curve, it will appear the error prompt.

⑤: File name: Select the file name of the backup data in the flash. When the backup content chooses all files, the default prefix of folder name is F+date; when choosing a single historical file, the default prefix of folder name is DAT; when choosing the alarming record, the default prefix of folder name is ALM; when choosing power-off record, the default prefix of folder name is PWR; when choosing the file list, the default prefix of the folder name is REC. Users can modify the file name as required.

⑥: Operation keys:

Press the "Switch" key to switch to other display screens.

Press the "Up shift" key to move upwards the cursor, then press the "Enter" key to modify the cursor, and then press the "Enter" key to confirm exit after modification.

Press the "Down shift" key to move downward the cursor, then press the "Enter" key to modify the cursor, and then press the "Enter" key to confirm exit after modification.

Press the "Backup" key, the instrument will appear "backup in progress", when the USB's progress bar is completed, the instrument will remind that "backup completed", if the progress bar

is not completed, press "Delete" key, the instrument will remind "deleted" backup data is stopped.

When there is no SD card connection, there will be no SD card; when there is SD card connection, there will be no prompt, there will be corresponding icon display in the status bar; when there is no flash connection, there will be no flash prompt by pressing the "Backup" key; when there is a flash connection, there will be corresponding icon display in the status bar, and all files will be automatically backed up to the folder.

! Note: the parameters under the backup contents will become shadow prompt, which it indicates that the parameters cannot be set.

4.11 Power-off screen

It displays the relevant records of the power-off and power-on duration of the instrument, including power-off and power-on time, total power-off times and total power-off duration, which can save maximum 100 alarming messages. When the number of saved items is up, the new power-off record files will cover the earliest records.

PWR View				2018-7-24 16:20:22
No.	PWR Off Time	PWR On Time	PWR Off Length	
009	2018-7-24 10:50:50	2018-7-24 11:00:00	0000d-00h:10m:10s	
008	2018-7-24 10:30:30	2018-7-24 10:40:40	0000d-00h:10m:10s	
007	2018-7-24 10:10:10	2018-7-24 10:20:20	0000d-00h:10m:10s	
006	2018-7-24 09:50:50	2018-7-24 10:00:00	0000d-00h:10m:10s	
005	2018-7-24 09:30:30	2018-7-24 09:40:40	0000d-00h:10m:10s	
004	2018-7-24 09:10:10	2018-7-24 09:20:20	0000d-00h:10m:10s	
003	2018-7-24 08:40:50	2018-7-24 09:00:00	0000d-00h:10m:10s	
002	2018-7-24 08:20:30	2018-7-24 08:30:40	0000d-00h:10m:10s	
001	2018-7-24 08:00:10	2018-7-24 08:10:20	0000d-00h:10m:10s	
PWR Off Counts: 00009 Off Time Length: 00000d-01h:31m:30s				

①: Serial number: The Serial number of power-off records is arranged according to the time pattern. The closer the occurrence time is, the larger the Serial number is.

②: Power-off duration: Power-off duration of instrument.

③: Power-on duration: The duration when the meter reaches the measuring frame after power up.

④: The power-off duration: The duration of each power failure.

⑤: The total times of power-off: The total times of power-off.

Total duration: Accumulating the duration of each power-off

⑥: Operation keys:

Press the "Switch" key to switch to other display screens.

Press the "Up shift" key to move upwards to view the power-off record list.

Press "Down shift" key to move downwards to view the power-off record list.

Press the "Page Up" key to page up the page to view the power-off record list.

Press the "Page Down" key to page down to view the power-off record list.

4.12 Configuration screen

Config 2018-7-24 16:20:22

Password 000000 *

SYSTEM RECORD

DISPLAY INPUT

OUTPUT ABOUT

Left Right Up Down Enter Exit

The password is made up of 6-digit number and *.

Note: If the password is set wrong, the user will not be able to enter the configuration screen.

The factory default password is 000000.

The following will introduce each configuration screen:

4.12.1 System configuration

System 2018-7-24 16:20:22

Language English Password 000000

Time 2011-07-29 16:20:22

CJ Adjust 0.0 23.0°C BurnOut High

Address 001 Baudrate 9600

IP Addr 192.168.000.002 IP Port 0502

Aut Print 0000m Prt Time 00:00

Alm Print OFF clear data

Left Right Enter Exit

★Language selection: Simplified Chinese and English are optional.

★User password: Users can set passwords according to their needs.

★Record Name: Users can set record's name according to their own needs, factory default: paperless recorder.

★Date &time: display "Year- Month – Day Hour – Minute- Second", it can modify and adjust time.

★Cold end adjustment: adjust and display the temperature at cold end.

★Treatment of interruption: low limit of measurement range, high limit of measurement range, maintain the preceding value, - - optional.

★Correspondence address: Address range: 1~255.

★The baud rate : 1200, 2400, 4800, 9600, 19200, 38400, 57600 are optional.

★IP address: The IP address of Modbus Tcp.

★Port: The port number of Modbus Tcp.

★Timing printing: Set the time for timing printing .

★Starting time: Set the starting time of timing printing.

★Alarming printing: On and Off are optional.

★Clear data: Clear all stored data in instrument memory, including historical data, alarming list, file list, power-off record.

Operation: in this screen,

Move the cursor according to the "Left shift" and "Right shift" keys.

Adjust the numeric value according to "Down shift", "Up shift", "+" and "-".

Press the "Enter" key to confirm the execution; when the cursor moves to clear the data, press the "Enter" key and pop up the dialog box "whether to clear all data", select "Yes" to perform the clearance of historical data, and choose "No" to abandon the clearance of historical data.

Press the "Esc" key to exit this screen. If the content of the screen is modified, it will pop up the dialogue box "Do you save the modified parameters?" In the dialog box, select Yes to save the modified parameters and No to save the modified parameters.

4.12.2 Record configuration

The screenshot shows a 'Record' configuration screen with a blue header bar containing the title 'Record' and the date/time '2018-7-24 16:20:22'. The screen contains several rows of settings, each with a label and a dropdown menu or input field:

- Rec Mode: Cycle
- Rec Type: Real
- Rec Cond: Power
- Man Rec: Stop
- Alm Rec: Chan01, LL
- Relay Rec: D001
- Time Rec StTime: 08: 30: 00, EndTime: 08: 40: 00

At the bottom of the screen, there is a control bar with buttons for 'Left', 'Right', four empty boxes, 'Enter', and 'Exit'.

★Record mode: non-circulation mode and circulation.

Non-circulation: Automatically stop recording when the recording space of the instrument is full or reach 100 pieces.

Circulation: When the record space is full, it will continue to record from the first file .According to the way of replacing the old file with the new file, when the number of records reaches 100, the first file will be deleted, the serial number of the other files will move forward in turn, and then create a new file to continue recording.

★Recording interval: The interval such as 1 second, 2 seconds, 4seconds, 6 seconds, 15 seconds, 30 seconds, 1 minute, 2 minutes, 4 minutes is optional.

★Recording types: Real-time value, average value, maximum value and minimum value are optional.

Real-time value: Directly take the real-time value corresponding to the time of recording point.

Average value: The average value of real-time data between the recording points before and after. The average value is calculated by weighted average method.

Maximum value: Take the maximum value of the real-time data between the recording points before and after.

Minimum value: Take the minimum value of real-time data between the recording points before and after.

★Power-on record: New file, continuation from power-off is optional.

New file: Create a new file list to record after power-on.

Continuation from power-off: After power on, the files in record before power off can be traced to continue recording; when this function is selected, the data during power off can be displayed ---.

★Triggering conditions: Manual, power-on, alarming, relay, timing are optional (Note: Which triggering conditions under the corresponding triggering mode can be displayed and modified).

Manual trigger: Enter the storage operation interface of the instrument, manually stop or manually start data storage records.

Power on: Every time after the power-on is started, the instrument automatically creates new files and records data.

Alarming trigger: It can be set to start data storage record when a certain alarming corresponds to a certain channel, and if recording is stopped, the alarming is over.

Relay trigger: When a certain limited relay alarming, start data storage records, and stop recording when the relay alarming are over.

Relay trigger: It can set that while a limited relay is alarming, start the data storage record, and while the relay alarming is over, stop recording .

Timing trigger: When the timing cycle period is set 24 hours, set the starting time and end time so that the instrument can only conduct the store data recording in the set time period every day.

Operation: in this screen,

Move the cursor according to the "Left shift" and "Right shift" keys.

Adjust the numeric value according to "Down shift", "Up shift", "+" and "-".

Press the "Enter" key to confirm the execution;

Press the "Esc" key to exit this screen. If the content of the screen is modified, it will pop up the dialogue box "Do you save the modified parameters?" In the dialog box, select "Yes" to save the modified parameters and "No" to save the modified parameters.

4.12.3 Display configuration

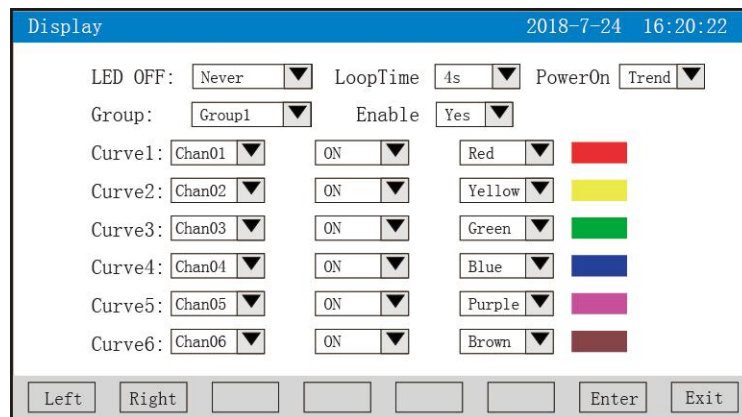

★Closing LCD: You can select after 5, 10, 30 minutes, 1 hour, and never close.

★Cycle interval: Cycle shows the interval for next combination, 4 seconds, 8 seconds, 15 seconds, 30 seconds are optional.

★Boot screen: Boot screen can choose the real-time curve, bar chart screen, digital display screen, historical curve, file list, power-off record, before power-off.

★Curve combination: Each curve combination can include 6 curves, with totally 10 kinds of curve combination can be selected according to the actual needs, and display in real-time curve screen.

★Start using: Select "Yes", the corresponding combination of curves can be displayed on the real-time curve screen, but select "No" ,there is no display.

★Curve 1 to 6: Select the name of the channel to display, whether to show the display and the color of the curve.

Operation: in this screen,

Move the cursor by pressing the keys "Left shift" and "Right shift".

Select the wanted contents by pressing the keys "Down shift", "Up shift", "Page down" and "Page up".

Press the "Enter" key to confirm the execution;

Press the "Esc" key to exit this screen. If the content of the screen is modified, it will pop up the dialogue box "Do you save the modified parameters?" In the dialog box, select "Yes" to save the modified parameters and "No" to save the modified parameters.

4.12.4 Input configuration

The screenshot shows the 'Input' configuration interface. At the top, it displays the date '2018-7-24' and time '16:20:22'. The main configuration area includes:

- Channel:** Chan01 (dropdown)
- Name:** Chan01 (text box)
- Signal:** 4-20mA (dropdown)
- Unit:** °C (text box)
- Range:** 0.0 to 100.0 (text boxes)
- Accumulate:** OFF (dropdown)
- Filter:** 0.0s (text box)
- Cut Off:** 0.0% (text box)
- Adjust y=kx+b:** k=1.0, b=0.0 (text boxes)
- Alarm Settings:** Four columns for LL, L, H, and HH. Each column has an 'ALm Func' (OFF/ON), 'ALm Relay' (D001/D002), 'ALm Value' (10.0, 20.0, 80.0, 90.0), and 'ALm Zone' (1.0).

At the bottom, there are navigation buttons: Left, Right, Copy, Enter, and Exit.

★Configuration channel: Select the number of channel for display configuration.

★Bit number: It indicates the bit number of the engineering corresponding to the display channel. As for the setting method, please refer to Section 4.12.4.1 Introduction to Input Method.

★Signal types: B, S, K, E, T, J, R, N, F2, Wre3-25, Wre5-26, Cu50, Cu53, Cu100, Pt100, BA1, BA2, 0~400Ω, 0~20mV, 0~100mV, ±20mV, ±100mV, 0~20mA, 0~10 mA, 4~20mA, 0~5V, 1~5V, √0~10mA, √4~20mA, √0~5V, √1~5V, nil.

The permitted ranges of all signals are stated as follows:

Signal model	Scope of range	Signal model	Scope of range	Signal model	Scope of range
B	400~1800°C	Cu50	-50.0~150.0°C	0~20mA	-9999~99999
S	-50~1600°C	Cu53	-50.0~150.0°C	0~10mA	-9999~99999
K	-200~1300°C	Cu100	-50.0~150.0°C	4~20mA	-9999~99999
E	-200~1000°C	Pt100	-200.0~650.0°C	0~5V	-9999~99999
T	-200.0~400.0°C	BA1	-200.0~600.0°C	1~5V	-9999~99999
J	-200~1200°C	BA2	-200.0~600.0°C	reserve	
R	-50~1600°C	0~400Ω Linear resistance	-9999~99999	reserve	
N	-200~1300°C	0~20mV	-9999~99999	0~10mA radiation	
F2	700~2000°C	0~100mV	-9999~99999	0~20mA	

			99999	radication	
Wre3-25	0~2300°C	±20mV	-9999~ 99999	0~5V radication	
Wre5-26	0~2300°C	±100mV	-9999~ 99999	1~5V radication	

★Unit: It indicates the engineering unit corresponding to the display channel. As for the setting method, please refer to Section 4.12.4.2 Introduction to Unit Input Method.

★Range: Record the high and low limit ranges of data ,with the set scope is -9999~19999. The bit number of decimal points in the channel is determined by modifying the position of decimal points in the high limit of the range.

★Filter time: The times of sampling by instrument can be modified to prevent the measured value from runout. Range is 0~9.9 seconds. Example of the relationship between the display value of the instrument and filter time are given. When the analog input is given, the filter time is set to 3.0 seconds, then the instrument automatically averages the sampling value within 3 seconds (filtering time 3 x sampling period 1 second), and updates the display value by recursive method.

★Small signal cutoff: Measured value < (high limit value of range — low limit value of range) × the percentage of small signal cutoff + low limit value of range, at this time, the instrument is displaying the low limit value of range and set 0 to switch off the function of small signal cutoff. Range: 0~99.9%.

★Linear correction: The quantity of work is linearly corrected according to formula $y = Kx + b$, where K represents linear coefficient and B represents zero-point correction. Under default state, K=1.0, b=0.0,it will not be corrected. X indicates the quantity of work the channel shall display before correction, and Y indicates the value the channel shall display after correction.

★The alarming of low low limit, low limit, high limit, high high limit , and the numeric value of hystersis for this channel ,please note the following points:.

The range of low low limit, low limit, high limit, high high limit, and the numeric value of hystersis is - 9999~19999, and the input mode is the same as the range's.

Alarming function: Off: The alarming function is switched off, On: The alarming function is switched on.

Alarming contacts: Select the serial number of the relay's contacts. D001 to D018 correspond to the output of relay contacts from No. 1 to No. 18. "Nil" means no output.

Operation: in this screen,

Move the cursor by pressing the keys "Left shift" and "Right shift".

Select the wanted contents by pressing the keys "Down shift", "Up shift", " Page down " and " Page up".

Press the "Enter" key to confirm the execution;

Press the "Esc" key to exit this screen. If the content of the screen is modified, it will pop up

the dialogue box "Do you save the modified parameters?" In the dialog box, select "Yes" to save the modified parameters and "No" to save the modified parameters.

Press the keys "Copy" and "Paste" to copy the parameters of the configuration channel numbers that need to be copied to other channels. For example, if we need to copy the parameters of channel 01 to channel 02, as long as the cursor press the "Copy" key when the configuration channel the cursor is locating in is channel 01, and then change the configuration channel to channel 02 and press the "Paste" key. When the configuration of several channels is exactly the same, this function can greatly reduce the configuration time.

4.12.4.1 The input method of "bit number" in channel configuration is introduced.

The input method of this instrument adopts T6 input method, which is similar to the keyboard input method of mobile phone. It can select and input Chinese characters, numbers, English and special symbols through few keyboard operations. It is easy to operate, learn and use, which it uses international coding to solve the input problem of the bit numbers and special units of Chinese character.

When the cursor moves to the "Bit number", press the "Enter" key, the following input method screens will appear.



①: Input: display field: It displays input characters.

②: Soft keyboard: 26 phonetic letters are displayed while inputting phonetic letters.

Display 26 phonetic letters while inputting capital letters

Display 26 lowercase letters while inputting lowercase letters

Display (0~9) and strigula and decimal points while inputting figures

Display 30 special symbols while inputting special symbols .

③: Display field of phonetic letters combination(while only using phonetic letter input).

④: Text selection field (while only using Pinyin input).

⑤: Selection bar of input method, where the input method can be selected here.

⑥: Operation keys:

Move the cursor to select the required characters by pressing the keys "Left shift" and "Right shift" and "Up".

Press the "Cursor" key: move the cursor to the selection bar of input method to switch the input method; press the "Cursor" key when ▲ appears in a text selection bar, and then press the

keys "Left shift" and "Right shift" to select the required characters.

Press "Delete" key to delete the character of the cursor.

Press the "Select" key to select the character of the cursor.

Press the "Complete" key to exit the input method and complete the input of the bit number.

Press the "Cancel" key to exit the input method screen.

I. Phonetic letter input method screen

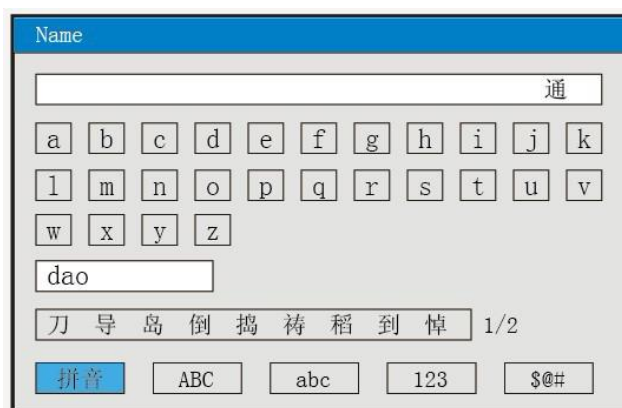

Using phonetic letters input method: Phonetic letters input method is to represent by pronouncing the Chinese characters in Chinese phonetic letter.

Input the Chinese character "道",

1. Press the "Enter" key to enter the input method screen (the default is phonetic letters input method).

2. Press the keys "Left shift", "Right shift" and "Up shift" to move the cursor to select the phonetic letter "d".

3. Press the "Select" key to select, display "d" in the display field of the phonetic letters combination.

4. Press the keys "Left shift", "Right shift" and "Up shift" to move the cursor to select the phonetic letter "a".

5. Press the "Select" key to select, display "da" in the phonetic letters combination display field.

6. Press the "Left shift", "Right shift" and "Up shift" keys to move the cursor to select the phonetic letter "o".

7. Press the "Select" key to select, display "Dao" in the phonetic combination display field. In the text selection field, the pre-selected Chinese character "道" will appear.

8. Press the "Cursor" key and ▲ appears below the text selection field.

9. Select the Chinese character "道" by pressing the keys "Left shift" and "Right shift".

10. Press the "Select" key to select the input and display the "道" in the input field.

11. Press the "Complete" key to exit the input method and complete the input of the bit number.

Note: When the homophone Chinese characters exceed 9, press the "Right shift" key to move

to the next page.

II. Capital letter input method screen

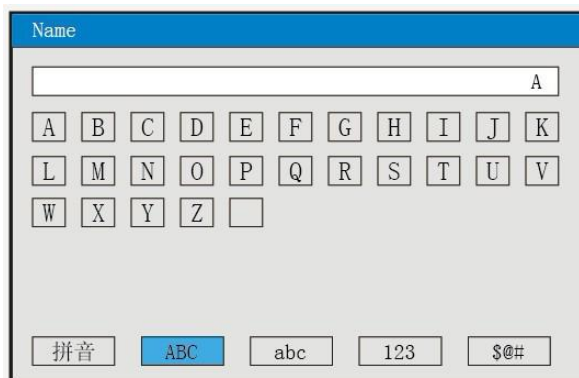

Input the capital letter "A".

1. Press the "Enter" key to enter the input method screen.
2. Move the cursor to the input method selection field by pressing the "Cursor" key.
3. Press the keys "Left shift" and "Right shift" to move cursor to select .
4. Press the "Cursor" key to move the cursor to the software disc field with the capital letters input.
5. Press the "Select" key to select, display "A" in the input field.
6. Press the "Complete" key to exit the input method and complete the input of the bit number.

III. Lowcase letter input method screen

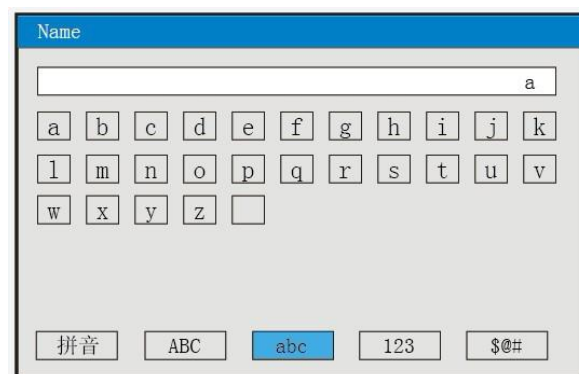

Input the lowercase letter "a",

1. Press the "Enter" key to enter the input method screen.
2. Move the cursor to the input method selection field by pressing the "Cursor" key.
3. Press the keys "Left shift" and "Right shift" to move cursor to select .
4. Press the "Cursor" key to move the cursor to the software disc field with the lowercase letters input.
5. Press the "Select" key to select, display "a" in the input field.
6. Press the "Complete" key to exit the input method and complete the input of the bit number.

IV. Figure input method screen

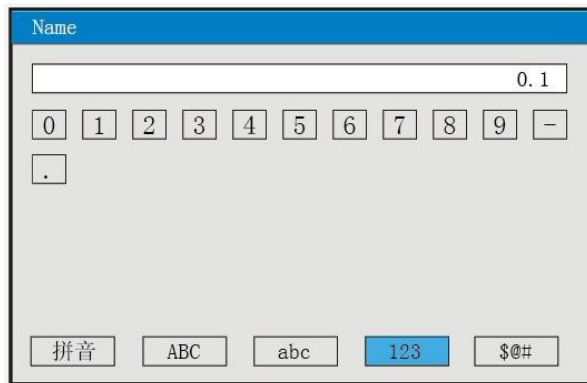

Input figure"0.1" ,

1. Press the "Enter" key to enter the input method screen.
2. Move the cursor to the input method selection field by pressing the "Cursor" key.
3. Press the keys "Left shift" and "Right shift" to move cursor to select .
4. Press the "Cursor" key to move the cursor to the software disc field with the figure letters input.
5. Press the "Select" key to select ,display"0" in the input field.
6. Press the keys "Left shift", "Right shift" and "Up shift" to move the cursor to select the ".".
7. Press the "Select" key to select, display "0" in the input field.
8. Press the keys "Left shift", "Right shift" and "Up shift" to move the cursor to select the "1".
9. Press the "Select" key to select ,display"0.1" in the input field.
10. Press the "Complete" key to exit the input method and complete the input of the bit number.

V. Special symbols input method screen

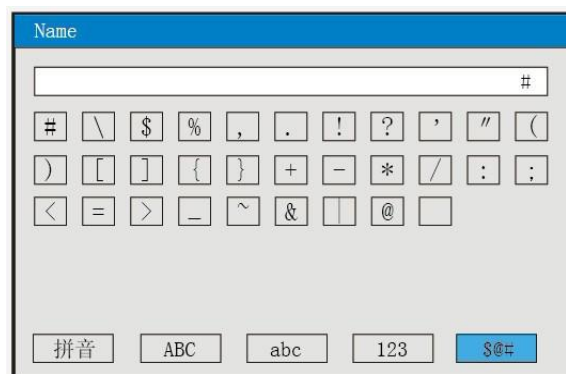

Input the special symbol"#",

1. Press the "Enter" key to enter the input method screen.
2. Move the cursor to the input method selection field by pressing the "Cursor" key.
3. Press the keys "Left shift" and "Right shift" to move cursor to select .
4. Press the "Cursor" key to move the cursor to the software disc field with the special symbol input.

5. Press the "Select" key to select, display "#" in the input field.

6. Press the "Complete" key to exit the input method and complete the input of the bit number.

4.12.4.2 The input method of "Unit" in channel configuration is introduced.

When the cursor moves to "Unit", press the "Enter" key, the following input method screens will appear.

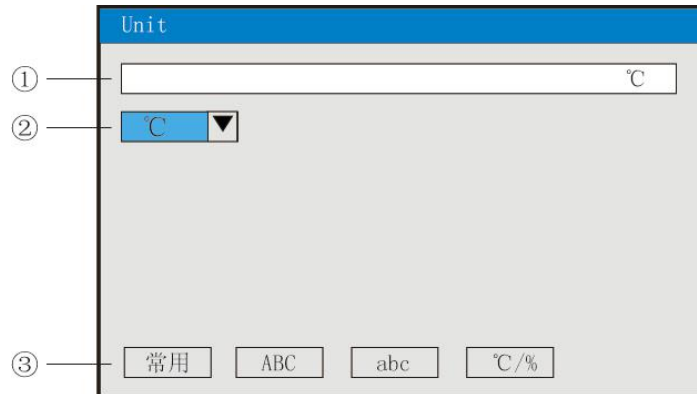

①: Input the display field: It displays the input unit symbol.

②: Soft keyboard: Input of common units

Display 26 phonetic letters while inputting capital letters

Display 26 lowercase letters while inputting lowercase letters

Display 16 special symbols while inputting special symbols.

③: Input method selection field, where select the required input method here.

④: Operation keys:

Press the keys "Left shift", "Right shift" and "Up shift" to move the cursor to select the required characters.

Press the "Cursor" key: move the cursor to the selection bar of input method to switch the input method;

Press the "Delete" key to delete the unit character of the cursor.

Press the "Select" key to select the unit character of the cursor.

Press the "Complete" key to exit the input method and complete the input of the unit.

Press the "Cancel" key to exit the input method screen.

I. Common units input method screen

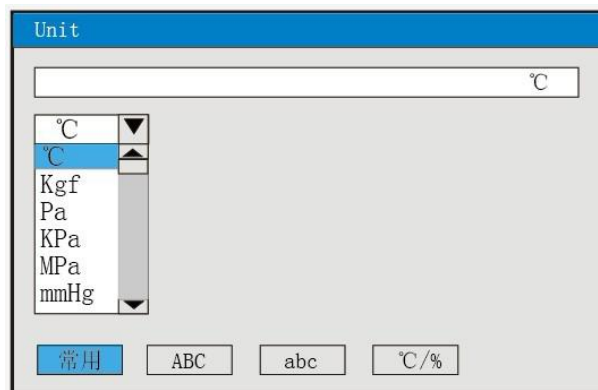

Input the common unit"°C"

1.Press the "Enter" key to enter the unit input method screen(Default is the common unit input method).

2. Press the "Enter" key , it will appear the ComboBox of the common unit input.And as for the common units ,they are°C, Kgf, Pa, KPa, MPa, mmHg, mmH2O, bar, t/h, Kg/h, L/h, m/h, Nm/h, t/m, Kg/m, L/m, m/m, Nm/m, t/s , Kg/s, L/s, m/s, Nm, /s, t, Kg, g, Nm, m, L, KJ/h, KJ/m, KJ/s, MJ/h, MJ/m, MJ/s, GJ/h, GJ/m, GJ/s, KJ, MJ, GJ, V, A, KW, Hz, %, mm, rpm.

3. Select the wanted unit"°C" by pressing the keys “Down shift”, "Up shift", " Page down " and " Page up".

4. Press the "Cursor" key to move the cursor to the software disc field with the special symbol input.

5. Press the "Select" key to select, display "°C" in the input field.

6. Press the "Complete" key to exit the input method and complete the input of unit.

II. Capital letter input method screen

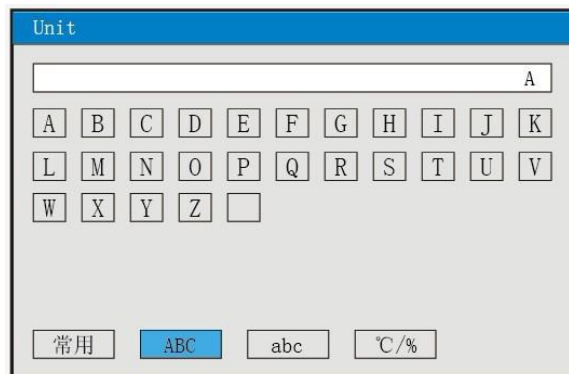

Input the capital letter "A",

1.Press the "Enter" key to enter the input method screen.

2.Move the cursor to the input method selection field by pressing the “Cursor” key.

3.Press the "Left shift" and "Right shift" keys to move cursor to select

4.Press the "Cursor" key to move the cursor to the software disc field with the capital letters input.

5.Press the "Select" key to select ,display “A” in the input field.

6.Press the "Complete" key to exit the input method and complete the input of unit.

III. Lowcase letter input method screen

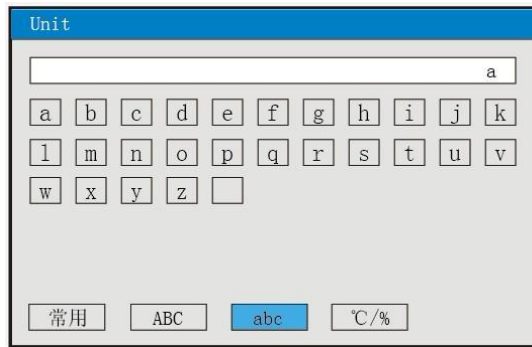

Input the lowercase letter "a",

1. Press the "Enter" key to enter the input method screen.
2. Move the cursor to the input method selection field by pressing the "Cursor" key.
3. Press the keys "Left shift" and "Right shift" to move cursor to select .
4. Press the "Cursor" key to move the cursor to the software disc field with the lowercase letters input.
5. Press the "Select" key to select, display "a" in the input field.
6. Press the "Complete" key to exit the input method and complete the input of unit.

IV. Special units input method screen

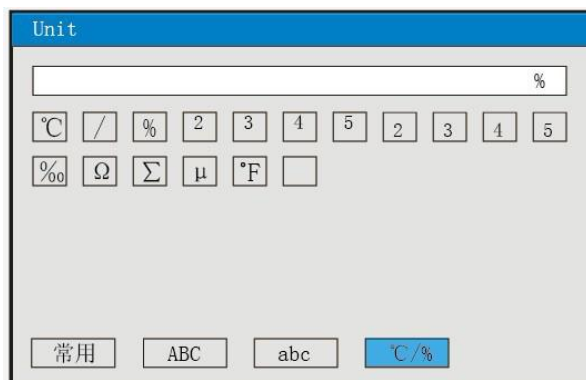

Input the special unit "%",

1. Press the "Enter" key to enter the input method screen.
2. Move the cursor to the input method selection field by pressing the "Cursor" key.
3. Press the keys "Left shift" and "Right shift" to move cursor to select .
4. Press the "Cursor" key to move the cursor to the software disc field with the special units input.
5. Press the "Select" key to select, display "%" in the input field.
6. Press the "Complete" key to exit the input method and complete the input of unit.

4.12.5 Analogue output

Output		2018-7-24 16:20:22				
Channel:	01-06 ▼					
Input	Type	Low	High	kx+b:b	kx+b:k	
AOut01:	Chan01 ▼	4-20mA ▼	0.0	100.000	0.0	1.000
AOut02:	Chan02 ▼	4-20mA ▼	0.0	100.000	0.0	1.000
AOut03:	Chan03 ▼	4-20mA ▼	0.0	100.000	0.0	1.000
AOut04:	Chan04 ▼	4-20mA ▼	0.0	100.000	0.0	1.000
AOut05:	Chan05 ▼	4-20mA ▼	0.0	100.000	0.0	1.000
AOut06:	Chan06 ▼	4-20mA ▼	0.0	100.000	0.0	1.000
Left		Right			Enter	Exit

★Output channel: 01-06

★Input channel: The input channel corresponding to the output channel. For example, "Output 02" corresponds to "Channel 05", and the analog output of No.2 channel follows the transmitted output of the measured value of input channel 5 .

★Output type: It may select 0~10 mA, 0~20 mA, 4~20 mA, 0 ~ 5V, 1 ~ 5V, 0 ~ 10V, nil.

★Output low Limit and output high limit: Adjust the high and low limit ranges of the transmitted output. Set the range : -9999~19999. The bit number of decimal points in the channel is determined by modifying the position of decimal points in the high limit of the range.

★Kx+b: Linear correction formula for analog output, b: output zero point transfer volume, K: output amplification ratio.

Operation: In this screen,

Move the cursor by pressing the keys "Left shift" and "Right shift".

Select the wanted contents by pressing the keys "Down shift", "Up shift", "Page down" and "Page up".

Press the "Enter" key to confirm the execution;

Press the "Esc" key to exit this screen. If the content of the screen is modified, it will pop up the dialogue box "Do you save the modified parameters?" In the dialog box, select "Yes" to save the modified parameters and "No" to save the modified parameters.

Note: As channels 7~12 terminals of the output channel and the alarming channel are shared. For example, the instrument has 8 channels for alarming outputs and 3 channels for analog outputs. Our company follows the principle of priority of alarming channels, so 01 and 02 of the output channels are occupied by the alarming channels. The output 03 corresponds to No.1 channel analog output, and the output 04 corresponds to No.2 channel analog output, and so on.

4.12.6 Functions list

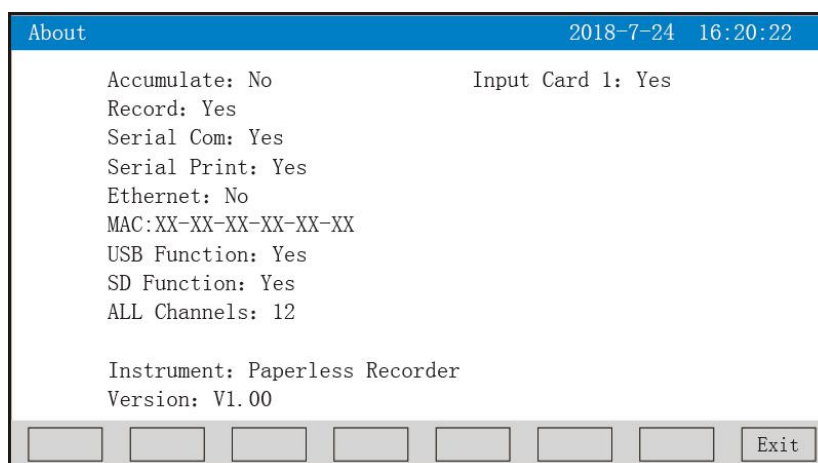

★View the functions list of the instrument: This screen can clearly see the functions of this instrument. If it has this function, it will show "Yes" and if it does not, it will show "No".

Operation:

In this screen, press the "Esc" key to exit the screen.

V. Communication

The instrument has the function of communication with the upper computer, which can complete the functions of parameter setting, data acquisition and monitoring of the low computer. With industrial control software, under Chinese WINDOWS, it can complete dynamic screen display, instrument data setting, chart generation, saving record, report printing and other functions. It can also acquire the data and curves in real time through the company's upper computer management software, and record the historical data and curves. Historical data and curves can also be exported to Excel for data processing.

This instrument provides users with two standard interfaces RS-485 and EtherNet for communication with the upper computer.

★RS-485 mode allows a upper computer to connect multiple recorders simultaneously. This communication mode is suitable for users of the terminal computer to form a network with the recorder, and to receive real-time data of the recorder and connect with various control systems.

★EtherNet communication allows multiple instruments to connect with the upper computer, and exchange data at 10M communication rate. It is suitable for large amounts of data communication between terminals and instruments. In case the communication distance is more than 300 m, it can be realized by optical fiber network. As long as the IP address is well selected in the recorder system configuration and set up in the computer management software, the Modbus Tcp can be carried out.

Please refer to Table 1 or 2 for specific parameters.

Table 1: 0x04 read command corresponds to the input register address table.

SN	Input address	Name of parameter	Data	Type	Remark
----	---------------	-------------------	------	------	--------

	register(decimal)		format		
Dynamic variable					
1	00	Measurement value of channel 1	Float	Read only	
2	02	Measurement value of channel 2	Float	Read only	
.....	Float	Read only	
n	2 (n-1)	Measurement value of channel n	Float	Read only	n: Number of channels
.....	Float	Read only	
11	20	Measurement value of channel 11	Float	Read only	
12	22	Measurement value of channel 12	Float	Read only	
13	120	Output state of contacts.	Long	Read only	No.0 ~ 11 bits represent the output states for No.1 ~ 12 contacts, 0: disconnect, 1: close.

Table2:0x03 Maintaining register address table that read command corresponds to 0x10 write command.

SN	Input register address (decimal)	Name of parameter	Data format	Type	Remark
Model of instrument					
1	0	Model of instrument	Char	Read only	Paperless recorder 0x62
Configuration parameter of instrument					
1	1	Language selection	Char	Read-write	0:Chinese 1:English
					After the upper computer modifies the display language, the instrument needs to power off and then power on again.
2	2	Reservation	Char		

3	3	Adjustment at the cold end	Short	Read-write	The data of the communication is the value after the adjustment value is magnified 10 times. For example: The adjustment value at cold end is -1.0, then the communication data is -10.
4	4	Equipment address	Char	Read-write	
5	5	Treatment of Interruption	Char	Read-write	0: high limit of range 1: low limit of range 2: maintain preceding values.
6	6	Baud rate	Char	Read-write	0...6respectively represents: baud rates of 1200 ...57600.
7	7	No.1,2 bytes of IP address	Short	Read-write	Example: The IP address is 192.168.100.2, and 2 bytes of the register address from low to high is 192 and 168 respectively.
8	8	No.3,4 bytes of IP address	Short	Read-write	Same as last example, 2 bytes of the register address from low to high is 100 and 2 respectively.
9	9	Port number of Ethernet	Short	Read-write	
10	10	Printing interval	Short	Read-write	
11	11	The Hour for the starting time of printing	Char	Read-write	
12	12	The Minute for the starting time of printing	Char	Read-write	
13	13	Alarming printing	Char	Read-write	0: Off 1: On
14	14	Number of input channel	Char	Write only	Value range: 0...11 respectively corresponds to channel 1... 12 (Note 1)
15	15	No.1, 2 character of bit number	Short	Read-write	See "Parameters of Channels" in the manual: Both bit numbers and Chinese characters in units are
16	16	No.3, 4 character of bit number	Short	Read-write	

17	17	No.5, 6 character of bit number	Short	Read-write	represented by ASCII codes.
18	18	No.7, 8 character of bit number	Short	Read-write	
19	19	Input type	Char	Read-write	
20	20	No.1, 2 character of unit	Short	Read-write	
21	21	No.3,4 character of unit	Short	Read-write	
22	22	No.5,6 character of unit	Short	Read-write	
23	23	Decimal point of channels	Char	Read-write	
24	24	Low limit	Float	Read-write	
25	26	High limit	Float	Read-write	
26	28	Accumulating function	Char	Read-write	
27	29	Filter coefficient	Char	Read-write	The value is 10 times after the magnification of the parameter.
28	30	Signal cutoff	Short	Read-write	The value is 10 times after the magnification of the parameter.
29	31	Linear correction proportional coefficient K	Float	Read-write	See "parameters of channels" in the manual:
30	33	Linear correction zero-point coefficient b	Float	Read-write	
31	35	Alarming type	Char	Write only	0...3 respectively corresponds to: low low limit, low limit, high high limit (Note 2).
32	36	Alarming function	Char	Read-write	0: OFF 1: ON
33	37	Alarming contact	Char	Read-write	
34	38	Alarming value	Float	Read-write	
35	40	Alarming's hystersis	Float	Read-write	
36	42	Number of input	Char		Value range: 0...5 (Note 3).

		channel		Write only	
37	43	Input channel	Char	Read-write	Value range: 0... 11 respectively corresponds to channel 1... 12 (Note 1)
38	44	Output type	Char	Read-write	0... 6 respectively corresponds to that of the output type: nil... (0-10V)
39	45	Low limit of output	Float	Read-write	See "parameters of channels" in the manual:
40	47	High limit of output	Float	Read-write	
41	49	Output correction proportional coefficient K	Float	Read-write	
42	51	Output correction zero-point coefficient b	Float	Read-write	
43	53	Close LCD	Char	Read-write	0...4 respectively corresponds to the parameters: 5 minutes...never.
44	54	Circulate the display time	Char	Read-write	0...3 respectively corresponds to the parameters: 4-30 seconds.
45	55	Display boot screen	Char	Read-write	
46	56	Serial number of curve combination	Char	Write only	0... 9 respectively corresponds to 1..10 curve combination.
47	57	Whether to start using	Char	Read-write	0:No 1:Yes
48	58	Serial number of curves	Char	Write only	0...5 respectively corresponds to the number of curves of 1...6; One combination contains 6 curves.
49	59	Numbers of channels correspond to the curves	Char	Read-write	Value range: 0...11 respectively corresponds to channel 1... 12 (Note 1).
50	60	Whether to display curve or not	Char	Read-write	0:No 1:Yes
51	61	Curve color	Char	Read-write	0...5 respectively corresponds

					to one another: Red... brown
52	62	Record model	Char	Read-write	0: No 1:Yes
53	63	Record interval	Char	Read-write	0...8 respectively corresponds to 1 second...4minutes.
54	64	Record type	Char	Read-write	0...3 respectively corresponds to real-time values... minimum value.
55	65	Power-on record	Char	Read-write	
56	66	Record trigger	Char	Read-write	0...4 respectively corresponds to manual... timing
57	67	Manual trigger	Char	Read-write	0:No 1; Yes
58	68	Input channel of alarming trigger	Char	Read-write	Value range:0...11 respectively corresponds to channel 1... 12 (Note 1)
59	69	Alarming type for alarming trigger	Char	Read-write	0...3 respectively corresponds to: low low limit, high high limit.
60	70	Bit number of relay triggered by relay	Char	Read-write	0...12respectively corresponds to alarming contacts ALM1 ...ALM12
61	71	Starting time for timing trigger: Hour	Char	Read-write	See "parameters of channels" in the manual:
62	72	Starting time for timing trigger: Minute	Char	Read-write	
63	73	Starting time for timing trigger: Second	Char	Read-write	
64	74	End time for timing trigger: Hour	Char	Read-write	
65	75	End time for timing trigger: Minute	Char	Read-write	
66	76	End time for timing trigger: Second	Char	Read-write	
67	180	Characters1,2 of the	Short	Read-write	

		equipment names			
68	181	Characters3,4 of the equipment names	Short	Read-write	Note: No 14 character must be 0.
69	182	Characters5,6 of the equipment names	Short	Read-write	
70	183	Characters7,8 of the equipment names	Short	Read-write	
71	184	Characters9,10 of the equipment names	Short	Read-write	
72	185	Characters11,12 of the equipment names	Short	Read-write	
73	186	Characters13,14 of the equipment names	Short	Read-write	

Note 1: The parameters of 12-channel input channel share the same register address. The parameters for which channel are determined through the input channel number (register address 14). So when you want to read and write a channel's parameter, you must write the input channel number first.

Note 2: Each input channel has four groups of alarming types, i.e. low low limit alarming, low limit alarming, high limit alarming and high high limit alarming. The four groups of alarming types share the same register address. The alarming types (register address 35) are used to determine the parameters for which group of alarming type . So to read and write the alarming parameters of an input channel, the alarming type must be first written .

Note 3: The parameters of 6-channel transmitted channel share the same register address. The parameters for which channel are determined through the channel number (register address 42). So when you want to read and write a channel's parameter, you must first write the transmitted channel number.

VI. Parts for the instrument

Name	Qty	Remarks
Specification	1 copy	This manual
Acceptance certificate	1piece	Manufacturing date
Mounting supports	4 Nos	For stabilizing the mounting of the panels
Optical disc	1piece	Management software of upper computer
Flash	1piece	When users place order on the transfer function of flash, whose capacity is subject to user order.

SD card	1piece	When users place orders on SD card storage function, SD card will be provided , whose capacity depends on the order by users.
---------	--------	---

Supmea

Headquarters

5th floor,Building 4,Singapore Hangzhou Science Technology Park,No. 6 street,
Hangzhou Economic Development Area,Hangzhou 310018,China

Singapore

2 Venture Drive #11-30 Vision Exchange Singapore

Philippines

Majestic Subdivision, Lot 1, 1800 Rainbow St, Marikina, 1811 Metro Manila, Philippines

✉ info@supmea.com

🌐 www.supmea.com

Supmea Automation Co.,Ltd.