



ROTARY PADDLE LEVEL SWITCH

SR2-10S



The paddle switch operating principle is simple, a unit is usually located through the bin wall at the top, middle or low level of a bin. During normal operation (no material present) a synchronous motor rotates the paddle at 1 RPM. When this paddle rotation is impeded by the material surrounding the paddle, the motor will stall and cause the micro switch to change state and indicate an alarm or control condition.

FEATURES:

- Airtight sealing device , outdoor application is available.
- Unique sealing ring design prevents dust ingress to housing along the shaft.
- The torque force is adjustable.
- The performance of torsion is stable and reliable.
- If the rotary paddle bears an extra overload, the motor will be appeared slide to prevent the inside mechanism being damaged.
- It is rationally designed, the inside mechanisms can be easily torn down for maintenance and replacement while still on the silo.

SPECIFICATIONS:

Power source	: 220VAC : 24VDC (Option)
Contact capacity	: SPDT 5A/ 250V AC
Power consumption	: 3W (max.)
Blade material	: SUS 304
Operating temp	: -20°C + 80°C
Operating pressure	: 2 kg/cm ²
Rotary speed	: 1 RPM
Torque	: 1N x m
Connection screw	: G 1"
Protection material	: IP65
Weight	: 0.7 Kg



Daimension (unit:mm.)

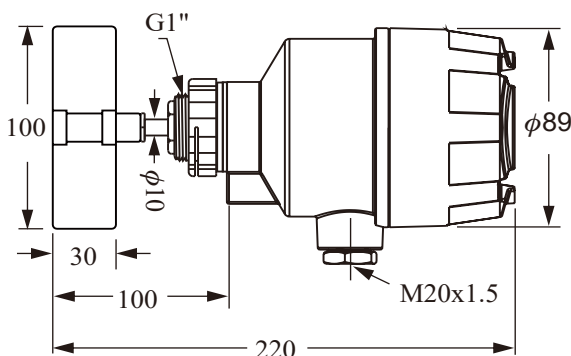

Wiring diagram

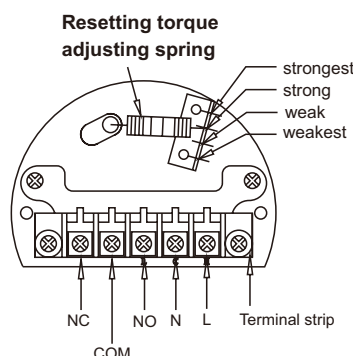

Application

