

## Basic Mark Sensor LX-111 Series

### ⚠ WARNING

- Never use this product as a sensing device for personnel protection.
- In case of using sensing devices for personnel protection, use products which meet standards, such as OSHA, ANSI or IEC etc., for personnel protection applicable in each region or country.

## 1 SPECIFICATIONS

Item	Type		Cable type	Connector type
	Model No.			
	NPN output		LX-111	LX-111-Z
	PNP output		LX-111-P	LX-111-P-Z
Sensing distance	10 mm ± 3			
Supply voltage	12 V to 24 V DC ± 10% Ripple P-P10% or less			
Power consumption	850mW or less (Power voltage 24V, Current consumption 35mA or less)			
Mode switching input	<b>&lt;NPN output type&gt;</b> <b>Mark mode</b>		<b>&lt;PNP output type&gt;</b> <b>Color Mode</b>	
	<ul style="list-style-type: none"> <li>· Low (ON): 0V to 2V DC</li> <li>· Source current 0.5mA or less</li> <li>· Input impedance 10kΩ approx.</li> </ul>		<ul style="list-style-type: none"> <li>· High (ON): 5V to +V DC</li> <li>· Sink current 3mA or less</li> <li>· Input impedance 10kΩ approx.</li> </ul>	
Output	<b>&lt;NPN output type&gt;</b>		<b>&lt;PNP output type&gt;</b>	
	<ul style="list-style-type: none"> <li>· NPN open-collector transistor</li> <li>· Max. sink current: 50mA (Note 1)</li> <li>· Applied voltage: 30V DC or less (between output and 0V)</li> <li>· Residual voltage: 1.5V or less (at 50mA (Note 1) sink current)</li> </ul>		<ul style="list-style-type: none"> <li>· PNP open-collector transistor</li> <li>· Max. source current: 50mA (Note 1)</li> <li>· Applied voltage: 30V DC or less (between output and +V)</li> <li>· Residual voltage: 1.5V or less (at 50mA (Note 1) source current)</li> </ul>	
Output operation	Mark mode: When mark detection, ON. Color mode: Coincidence-ON			
Short-circuit protection	Incorporated (Auto reset)			
Response time	Mark mode: 45 μs or less, Color mode: 150 μs or less			
Operation indicator	Orange LED (Light on when output is ON)			
Protection	IP67 (IEC)			
Ambient temperature	-10°C to +55°C (No dew condensation or icing allowed) Storage: -20°C to +70°C			
Ambient humidity	35% to 85% RH, Storage: 35% to 85% RH			
Emitting element	Red / green / blue LED (Emitting wavelength: 640nm / 525nm / 470nm)			
Material	· Enclosure: PBT · Operation buttons: Silicone rubber			
	· Operation panel, Lens: PC			
Cable	0.2 mm <sup>2</sup> 4-core cable, 2m long		(Note 2)	
	Division: Color code of cable	Division: Terminal No. of Connector		
Weight	Net weight: Approx. 110g Packing weight: Approx. 120g		Net weight: Approx. 50g Packing weight: Approx. 55g	

- Notes: 1) Measurement conditions, around Using temperature +23°C  
 2) The connecting cable is not supplied as an accessory for the connector type LX-111□-Z. Make sure to use the optional cables with connector below:  
 CN-24B-C2 (Straight type, 4-core, Cable length: 2m) CN-24BL-C2 (Elbow type, 4-core, Cable length: 2m)  
 CN-24B-C5 (Straight type, 4-core, Cable length: 5m) CN-24BL-C5 (Elbow type, 4-core, Cable length: 5m)

## 2 CAUTIONS

- This product has been developed / produced for industrial use only.
- Make sure to carry out wiring in the power supply off condition.
- Take care that wrong wiring will damage the sensor.
- Verify that the supply voltage variation is within the rating.
- Take care that if a voltage exceeding the rated range is applied, or if an AC power supply is directly connected, the sensor may get burnt or damaged.
- In case noise generating equipment (switching regulator, inverter motor, etc.) is used in the vicinity of this product, connect the frame ground (F.G.) terminal of the equipment to an actual ground.
- If power is supplied from a commercial switching regulator, ensure that the frame ground (F.G.) terminal of the power supply is connected to an actual ground.
- Do not use during the initial transient time (0.5 sec.) after the power supply is switched on.
- Take care that short-circuit of the load or wrong wiring may burn or damage the sensor.
- Do not run the wires together with high-voltage lines or power lines or put them in the same raceway. This can cause malfunction due to induction.
- Take care that the sensor is not directly exposed to fluorescent light from a rapid-starter lamp or a high frequency light device or sunlight etc., as it may affect the sensing performance.
- Do not touch the lens of the sensor by hand directly. If the lens becomes dirty, wipe it off with a soft cloth gently.
- When the inside lens is steamed up, unscrew the lens to get rid of the condensation.
- For LX-111□-Z, be sure to use the optional cable with connector.
- Extension up to total 100m is possible with 0.3mm<sup>2</sup>, or more, cable. However, in order to reduce noise, make the wiring as short as possible.
- This sensor is suitable for indoor use only.
- Do not use this sensor in places having excessive vapor, dust, etc., or where it may come in direct contact with water, or corrosive gas.
- Take care that the product does not come in contact with water, oil, grease, or organic solvents, such as, thinner, etc.

- Make sure that stress by forcible bend or pulling with 76N, or more, force is not applied to the sensor cable joint.
- This sensor cannot be used in an environment containing inflammable or explosive gases.
- Never disassemble or modify the sensor.

## 3 MOUNTING

- Care must be taken regarding the sensor mounting direction with respect to the object's direction of movement.

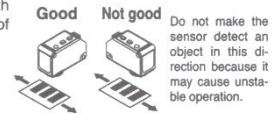

- The tightening torque should be 0.8N·m or less.

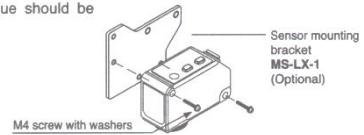

## 4 PART DESCRIPTION

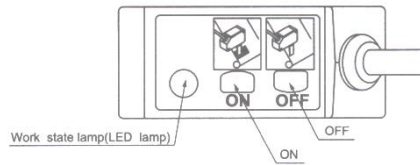

## 5 I/O CIRCUIT DIAGRAMS

- NPN output type

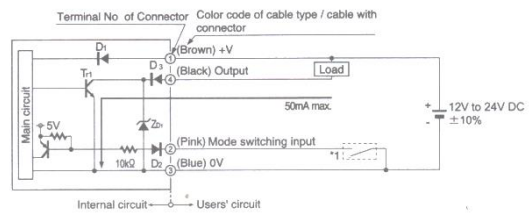

- PNP output type

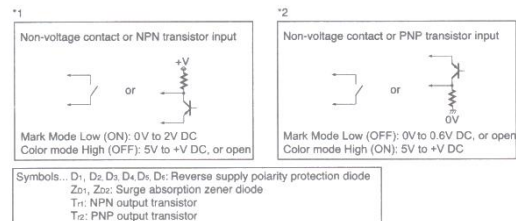
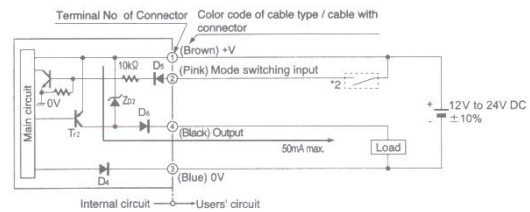

- Layout of connector pin of connector type LX-111□-Z

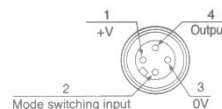

## 6 TEACHING METHODS

Before performing the Teaching, be sure to confirm the setting of mark mode or color mode.

In case of 2-point teaching of mark mode

- ① Press "ON key" when facing the measured color. Then the LED will flicker slowly.
- ② Press "OFF key" when facing the background. Then the LED will go out.
- ③ The threshold value is set at the mid-value between the step 1 and 2. In case stable sensing is possible: Good. In case stable sensing is impossible: ERR.

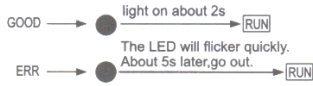

Note: When the system is in the state of ERR, please run Teaching again, otherwise the system will use the last results of teaching.

**In case of 1-point teaching of color mode**

- After aligning the beam spot to the mark to be detected. Press "ON key".
- In case stable sensing is possible :Good.  
In case stable sensing is impossible :ERR.

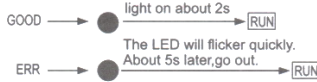

Note: When the system is in the state of ERR, please run Adjust Mode again, otherwise the system will use the last results of adjusting.

## 7 The Make Mode 'Gain' Function

While sensing is unstable, the judgments to the reflected light variation can be changed(Threshold value adjustment) through the 'Gain' function.

### ◆ Several conditions of the 'Gain' function

Conditions	Values	LED's twinkle times
1	$C = C - D * 80\%$	1
2	$C = C - D * 60\%$	2
3	$C = C - D * 40\%$	3
4	$C = C - D * 20\%$	4
5(Note1)	$C = C$	5
6	$C = C + D * 20\%$	6
7	$C = C + D * 40\%$	7
8	$C = C + D * 60\%$	8
9	$C = C + D * 80\%$	9

Note 1 : Factory Setting Condition  
(Which is the condition before the adjustment of the 'Gain' function.)

Note 2 : Value C stands for the threshold value;  
Value D stands for the reflected light variation between the mark(A) and the base(B).

### ◆ The 'Gain' Function

When the 'Gain' begins, the sensor is in the corresponding condition with the LED's twinkle times(X) after the LED is off for 0.5s without any operations.

Example:

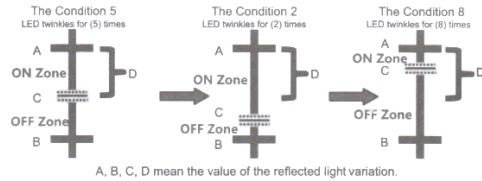

A, B, C, D mean the value of the reflected light variation.

Note: Value A stands for the reflected light variation of the mark;  
Value B stands for the reflected light variation of the base.

### ◆ The operation of the 'Gain' function

- For a better observation, please press the button OFF for one time at the normal condition when the LED is off, and then press the button ON along for approximately 6s until the LED is on. And now, the 'Gain' function begins.
- After the 'Gain' function begins, you may adjust the conditions of the 'Gain' by the button ON/OFF.
- It is not necessary to teach again after the adjustment and the sensor can be used immediately.

### ◆ The adjustment of the 'Gain' function and the display of the LED

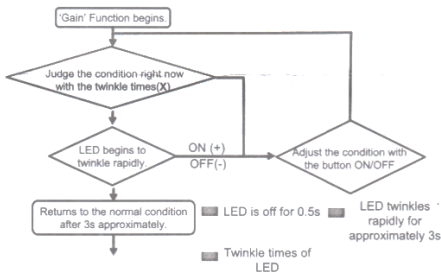

## 8 ERROR DISPLAY

Take measurement for the error as shown below:

Work state lamp (LED lamp)	Error content	Remedy
LED lamp have been fast scintillation, will not be put out	Shorten the load and flows overcurrent	Turn off the power supply and check the load.

## 9 DIMENSIONS (Unit: mm)

● Cable type / LX-111□

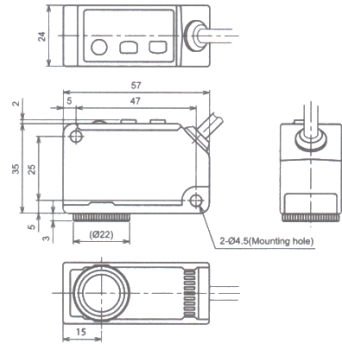

● Connector type / LX-111□-Z

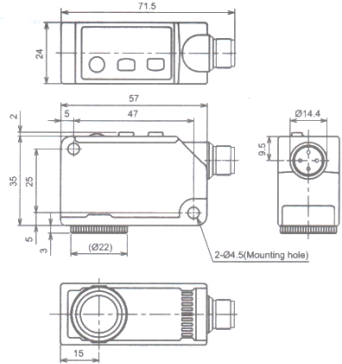

## 10 INTENDED PRODUCTS FOR CE MARKING

● The models listed under "1 SPECIFICATIONS" come with CE Marking. As for all other models, please contact our office.

● Economic operators' information in EU is as follows:

<Manufacturer>  
Panasonic Industrial Devices SUNX Suzhou Co., Ltd.  
97, Huoju Road, Suzhou New District, Jiangsu, China  
+86-512-6843-2580

<Importer>  
Panasonic Electric Works Europe AG  
Rudolf-Diesel-Ring 2, D-83607 Holzkirchen, Germany

<Contact for CE>  
Panasonic Marketing Europe GmbH Panasonic Testing Center  
Winsbergring 15, 22525 Hamburg, Germany

※ Above information is applied only when Panasonic Industrial Devices SUNX Suzhou Co., Ltd. exports this product to EU. This product is in conformity with CE Marking. The instruction manual similar or related to the product is available at our website. <https://www3.panasonic.biz/ac/e/fasys/index.jsp>