

6FM150 12V 150Ah (20hr) Sealed Lead Acid (SLA) Battery

The rechargeable batteries are lead-lead dioxide systems. The dilute sulfuric acid electrolyte is absorbed by separators and plates and thus immobilized. Should the battery be accidentally overcharged producing hydrogen and oxygen, special one-way valves allow the gases to escape thus avoiding excessive pressure build-up. Otherwise, the battery is completely sealed and is, therefore, maintenance-free, leak proof and usable in any position.



Battery Construction

Component	Positive plate	Negative plate	Container&Cover	Safety valve	Terminal	Separator	Electrolyte
Raw material	Lead dioxide	Lead	ABS UL94 HB	Rubber	Copper	Fiberglass	Sulfuric acid

General Features

- Absorbent Glass Mat (AGM) technology for efficient gas recombination of up to 99% and freedom from electrolyte maintenance or water adding.
- Positive and negative plates in lead-calcium-tin alloy
- Stable quality & high reliability
- Sealed construction
- Maintenance-free operation
- Low pressure venting system
- Low self discharge
- High rate discharge
- Valve Regulated Lead Acid (VRLA) battery
- V0 Class Flame-Retardant ABS (UL94V-0) container and cover is optional
- Six months shelf life at 25°C
- Design life 10 years depend on temperature, float charging*

Dimensions and Weight

Length(mm / inch)	483 / 19.02
Width(mm / inch)	170 / 6.69
Height(mm / inch)	240 / 9.45
Total Height(mm / inch)	240 / 9.45
Approx. Weight(Kg / lbs)	48.2 / 106

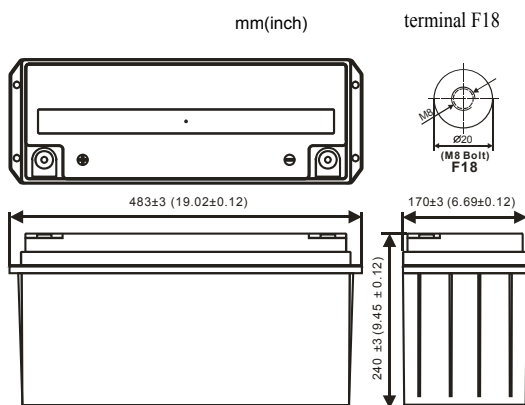

Performance Characteristics

Nominal Voltage	12V
Number of cell	6
Design Life at 25°C	10 years
Nominal Capacity 77°F(25°C)	
10 hour rate (15.0A, 10.8V)	150Ah
5 hour rate (28.2A, 10.2V)	141Ah
1 hour rate (106A, 9.6V)	106Ah
Internal Resistance	
Fully Charged battery 77°F(25°C)	3.4mOhms
Self-Discharge	
3% of capacity declined per month at 25°C (average)	
Operating Temperature Range	
Discharge	-20~60°C
Charge	-10~60°C
Storage	-20~60°C
Max. Discharge Current 77°F(25°C)	1,550A(5s)
Short Circuit Current	2,700A
Charge Methods: Constant Voltage Charge 77°F(25°C)	
Cycle use	14.4-14.8V
Maximum charging current	46.5A
Temperature compensation	-30mV/°C
Standby use	13.5-13.8V
Temperature compensation	-20mV/°C

Discharge Rates in Watts to Various End Voltage at 25°C(77°F)

End Voltage	1.80V	1.75V	1.70V	1.65V	1.60V
10 min	566	605	643	698	724
15 min	483	505	533	573	616
30 min	312	317	324	324	355
45 min	251	254	260	260	267
60 min	199	201	206	212	218
180 min	90.0	91.5	92.8	93.5	94.2
300 min	56.8	58.2	59.3	60.3	61.7
480 min	37.2	38.0	38.7	39.3	40.7
600 min	30.7	31.5	31.8	32.3	33.7

Discharge Rates in Amperes to Various End Voltage at 25°C(77°F)

End Voltage	1.80V	1.75V	1.70V	1.65V	1.60V
10 min	275	300	326	340	375
15 min	231	250	270	278	300
30 min	156	162	167	169	176
45 min	115	119	123	125	128
60 min	94.2	97.2	100	103	106
180 min	42.2	44.3	44.7	45.1	45.4
300 min	27.0	27.5	28.2	28.8	29.4
480 min	18.1	18.3	18.5	18.8	19.0
600 min	15.1	15.2	15.3	15.6	15.7

(Note)The above characteristics data are average values.

6FM150 12V 150Ah (20hr) Sealed Lead Acid (SLA) Battery

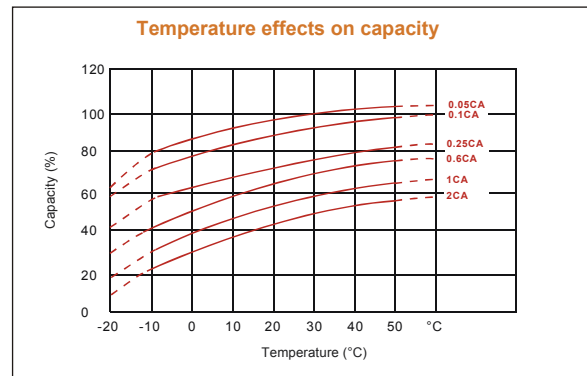
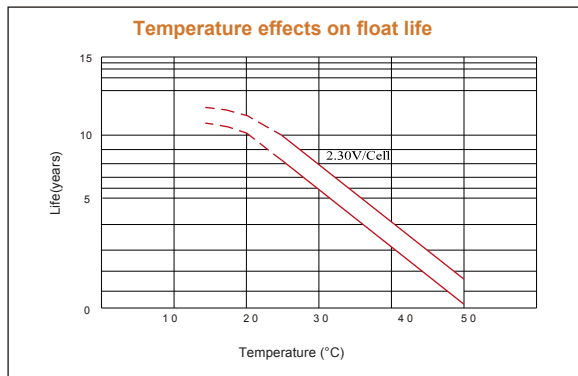
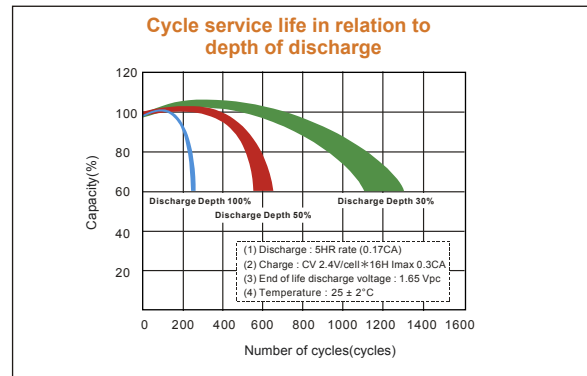
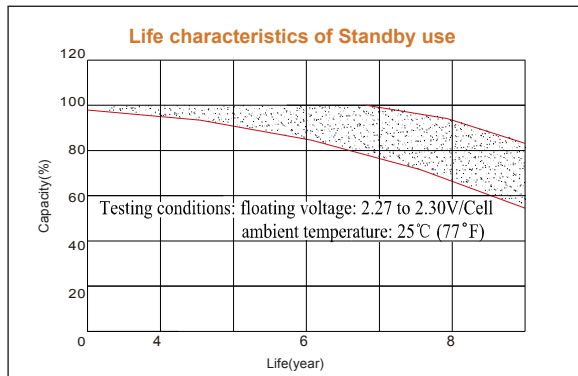
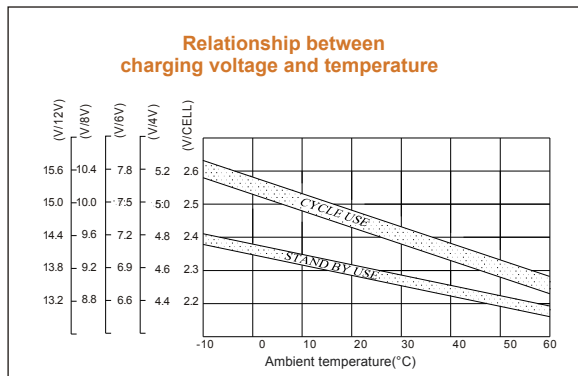
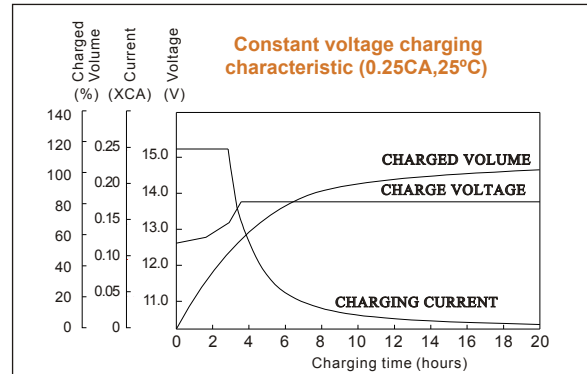
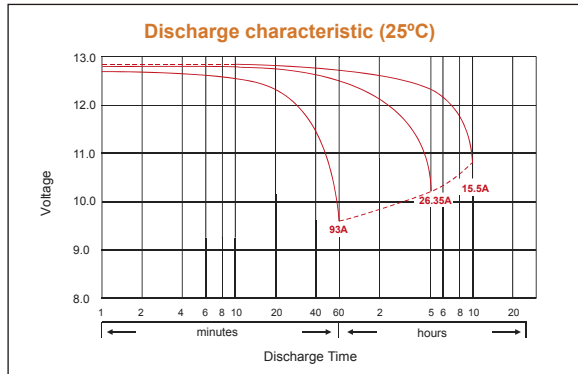

DENA ENGINEERING CO.,LTD.

185/1 Wongsawang Road, Wongsawang, Bangsue, Bangkok 10800 THAILAND

Tel. 02-587-7780, 02-910-9600 Fax. 02-587-1624 e-mail: dena@dena.co.th www.dena.co.th