

RETAIL WEIGHING SOLUTION™



Double tray type
(Plastic and stainless steel)



Rechargeable battery



Blue backlight LCD

ED-H SERIES

Smart Weighing Scale

ED-H is an advanced weighing scale with a high resolution and various functions. This sophisticated machine is appropriate for use in labs, jewelry and a vegetable store and also in the open market with rechargeable battery.

- Compatible with label and ticket printer
- Comparison function among weighing, counting and percentage [HI/OK/LO]
- RS-232 included
- Dust protection cover included



CAS

ED-H SERIES | Smart Weighing Scale

SPECIFICATIONS

Model	ED-H SERIES			
Max.capacity	3000g	6000g	15000g	30000g
Readability(e=d)	0.1g	0.2g	0.5g	1g
External resolution	1/30,000			
Internal resolution	1/600,000			
Display type	LCD			
Weight units	kg,g,lb,oz			
Zero range	± 2%			
Tare range	Full capacity by Subtraction			
Stabilization time	≤ 2 seconds			
Operation temperature	0°C ~ 40°C			
Power	AC adapter DC 12V/1A or 12V/800mA			
	Internal rechargeable sealed acid battery			
Battery life	80 hours continuous use with 12 hour recharge time			
Safe overload capacity	120% of capacity			
Product weight	4.5kg / 9.9lb			
Dimension(mm)	330(W) x 346(D) x 107(H)			
Pan size (mm)	Plastic: 304(W) x 220(D) , Stainless: 306(W) x 222(D)			

FEATURES

- High resolution for accurate weighing/counting
- Simple and easy operation (9 function keys)
- Easy icons on display for better understanding
- Counting & percentage mode
- Accumulation mode (Σ)
- Weight/Count/Percentage comparison function (HI/OK/LO) with alarm beeps
- RS-232C interface (PC/Printer)
- Rechargeable battery
- Double tray type (plastic and stainless steel)
- Barcode & Ticket print-out (DLP-50, DEP-50)
- Blue backlight LCD
- Dust protection cover

OPTIONS

- DEP-50 (Ticket printer)
- DLP-50 (Label printer)



CAS

Compatible with Label and Ticket printer

- ED-H can be connected with label or ticket printer for printing useful information such as weight, date and quantity.



Easy icons on display

- ED-H displays various functional icons that users can access high-level functions quickly and conveniently.



Large LCD display with bright blue backlight

- Bright blue backlight and 9 function keys enhance the operation of ED-H.

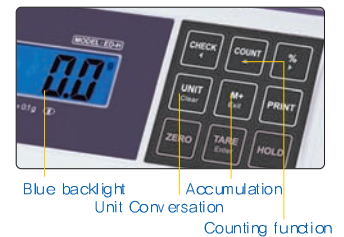

DIMENSIONS

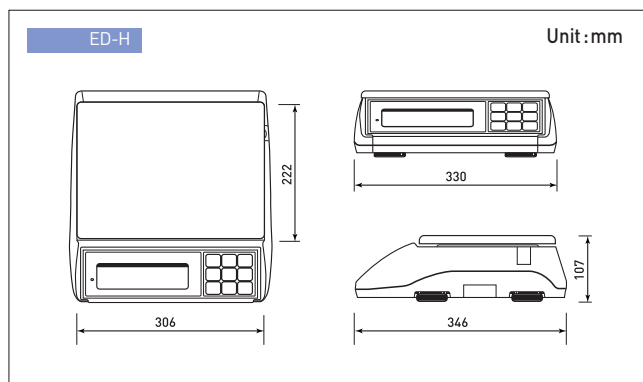

CDG | Computer Peripheral and Supplies Ltd.

Computer Peripheral and Supplies Ltd.

244 Soi Pattanakarn 53, Pattanakarn, Suanluang, Bangkok 10250 Thailand

Contact Us

- Facebook: facebook.com/cps.co.th
- Tel: 02-7224040 Ext.9
- Email: sales.dept@cps.co.th
- Website: www.cps.co.th

Follow Us

- Facebook, Line, WeChat, WhatsApp, Telegram: CPS
- Other: Tel: (66) 0-2322-9535, Fax: (66) 0-2322-7990

More Details

