

DENSO
DENSO WAVE

MOBILE COMPUTER
BHT-M80
SERIES

Driven by quality.

Scanning-Excellence
at its Core



Sets the bar in terms of reading performance:

The BHT-M80 Mobile Computer.

The BHT-M80 Android device is the result of continuous perfectionism!

Being fueled by the most powerful DENSO original scan engine to date, this mobile computer delivers a reading performance that will make you asking for nothing less ever again.

The installed Android™ 10 OS (with the option to upgrade to Android™ 11 at a later point) enables you to use the device intuitively without a long induction phase.

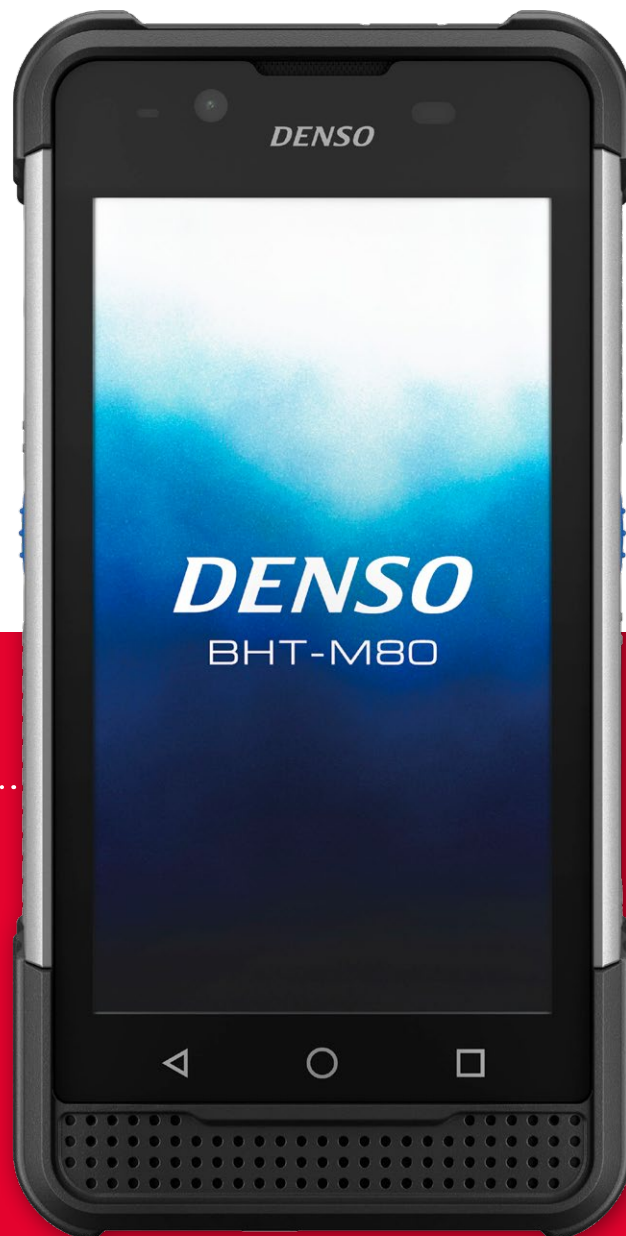

EXCELLENT OVERVIEW:

With the 5.0" screen everything that matters is in sight.



POWERFUL:

Octa-Core 2.2 GHz (Qualcomm SMD 660) for efficient processes without interruptions.

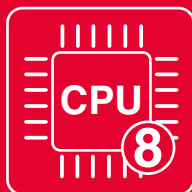

TOUGH:

Display with crack-resistant Asahi Dragontrail™ Pro glass fitted as a standard - one of the best in the industry.



ERGONOMIC:

Angled scan head for a natural hand posture, with the display always in view.



UP-TO-DATE:

Running Android™ 10 with the option to upgrade to Android™ 11 at a later point.

Focussing on the user's needs: The application areas.

The BHT-M80 demonstrates its capabilities especially where data has to be collected and processed in bulk. Its ergonomic concept, optimum view of the display and easy-to-use functions are perfect for speeding up reading processes.

Its great robustness makes the BHT-M80 ideal for countless indoor and outdoor applications.

These are just a few examples of its wide range of applications.

ORGANIZE LOGISTICS

Scan and locate your deliveries in real time using wireless LAN* – for tracking and tracing and improved route planning.

OPTIMISE FIELD SERVICE

Record the process status and progress immediately on site and communicate with head office whenever you need to – via wireless LAN*.

PROFESSIONALISE RETAIL

Whether it's for warehousing, ordering or sales management, collect data with precision – even if codes are damaged.

The result of continuous perfectionism: The technical highlights.

Wherever better performance is demanded, technology has to progress.

The BHT-M80 makes advanced automatic ID technology the standard.

Reads even difficult labels

Thanks to a new decode engine and a high resolution sensor, the BHT-M80 is able to read even the most difficult labels.

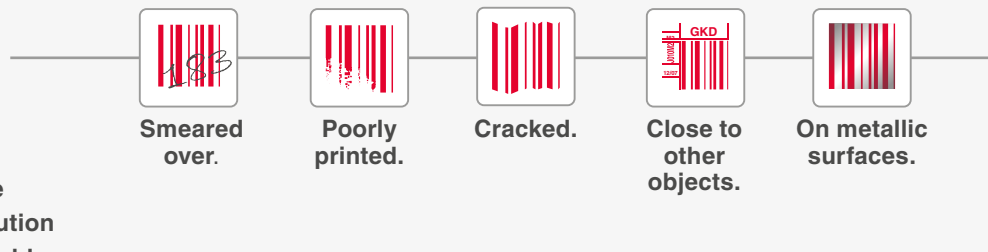

Superior scanning range

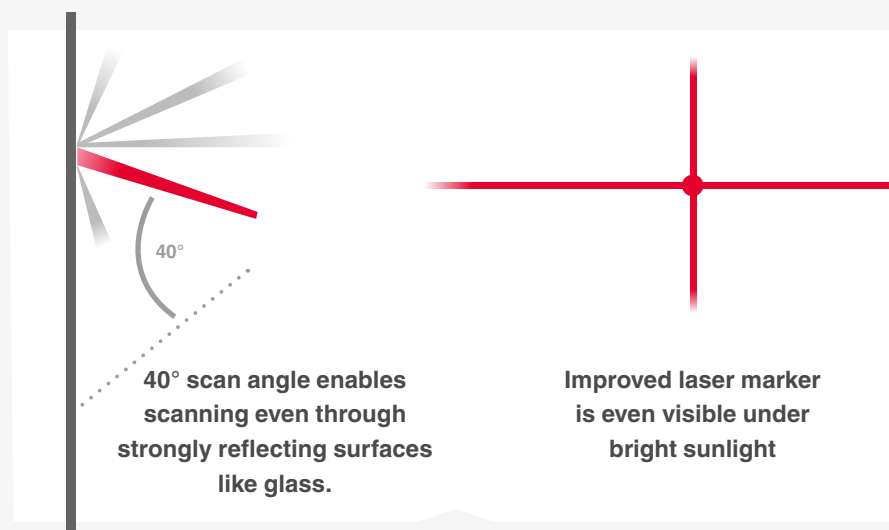
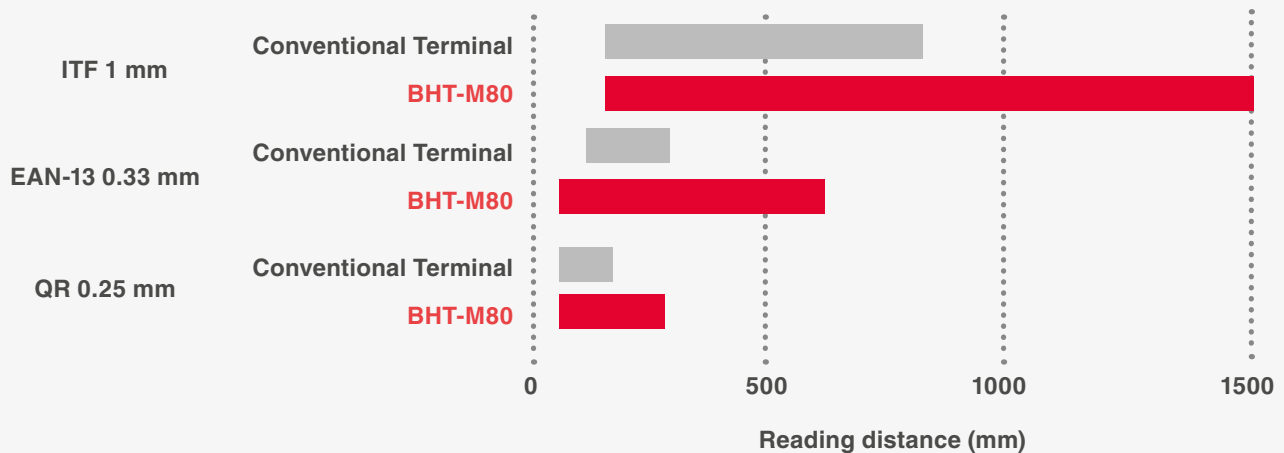

Tested to the extreme. It wouldn't be DENSO otherwise.

Innovation simply for the sake of innovating is not what DENSO's about. The BHT-M80 has passed our rigorous quality tests for robustness and durability, **even in the harshest conditions.**



warranty



Battery life

perfect for long working hours.



Works at extreme temperatures from **-20° to +50° Celsius.**

3.0 metres

Survived umpteen fall tests

from heights of up to 3.0 m.



IP67-certified

protection against water and dust.

SCANS QUICKLY AND EFFORTLESSLY THANKS TO ADVANCED TECHNOLOGY FROM DENSO.

It is no secret anymore that mobile data capture devices are a much faster option for processes like goods receipts or stock takings than the pen and paper method. The BHT-M80 accelerates those processes even more: thanks to a new decode engine combined with a high performance CPU, which leads to three times faster scanings than with conventional readers.

Superior reading speed.
Stress-less, continuous scanning.

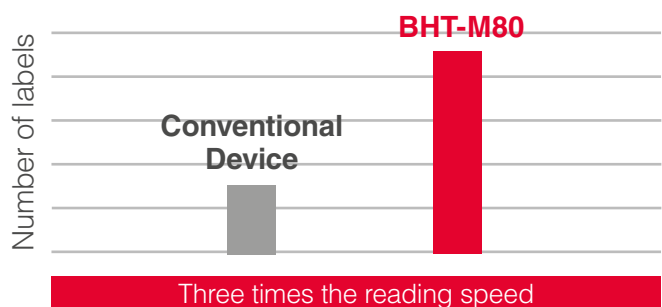

SPECIFICATIONS

| Model | BHT-M80-QWG | BHT-M80-QW | |
|----------------------------|--|--|--|
| OS | Android™ 10 | | |
| CPU | Qualcomm® SDM660 64 bit 2.20 GHz (Octa-Core) | | |
| Memory | RAM | 4 GB | |
| | Flash ROM | 64 GB | |
| Display | Screen size & resolution | 5 inch HD (720x1280) | |
| | Display device | Dot matrix liquid crystal display (colour) ¹ | |
| | Backlight | White LED | |
| | Reading method | Area sensor | |
| Reader | Supported code | 2D code | QR code®, Micro QR code, SQRC®, PDF417, Micro PDF417, Maxi code, Data Matrix (ECC200), and GS1 Composite |
| | | Barcode | EAN-13/8 (JAN-13/8), UPC-A/E, UPC/EAN (with add-on), and Interleaved 2 of 5 (ITF), Codabar (NW-7), CODE39, CODE93, CODE128, GS1-128 (EAN-128), and Standard 2 of 5 (STF), GS1 DataBar (RSS) |
| | | OCR | Supported ² |
| | Minimum resolution | 2D code | 0.127 mm |
| | | Barcode | 0.076 mm |
| Marker | Cross guide marker | | |
| Reading confirmation | Blue LED, speaker, and vibration | | |
| Keys | Number of keys | | 5 keys (including power key) + 2 trigger keys |
| Touch Panel | Asahi Dragontrail™ Pro ³ - wet touch / gloved fingertip / stylus | | |
| Communication | Wireless LAN connection | Standard | Compliant with IEEE802.11a/b/g/n/ac and MU-MIMO 2x2 |
| | | Frequency | 5 GHz-band (W52, W53, and W56, W58), 2.4 GHz-band (1 to 13 channels) |
| | Security | Encryption: OPEN, Enhanced Open, WEP(40/128), TKIP and AES WPA authentication: WPA and WPA2 and WPA3 User authentication: PSK, EAP-TLS, and PEAP | |
| | | WWAN | Supported: GSM/W-CDMA/LTE and VoLTE FDD-LTE (4G) - Bands 1, 2, 3, 4, 5, 7, 8, 12, 13, 17, 19, 20, 25, 26, 28 W-CDMA/UMTS/HSPA/HSPA+ (3G) - Bands 1, 2, 5, 6, 8, 19 GSM/GPRS/EDGE (2G) - Bands 850, 900, 1800, 1900MHz |
| | GPS | A-GPS/GLONASS/QZSS/BeiDou/Galileo | |
| | Bluetooth® | Bluetooth® Ver5.1+EDR/LE Supported Profile: RFCOMM/A2DP/AVCTP/ACDTP/GVDP/AVRCP/DUN/DI/HFP/HID/HSP/IOP/MAP/OPP/BNEP/PAN/PBAP/SAP/SPP | |
| | USB | USB2.0 (Type-C) | |
| NFC ⁴ | ISO/IEC14443A&B and FeliCa, ISO/IEC15693 (RFID) | | |
| Camera | Front 5MP autofocus, Rear 13MP autofocus | | |
| Card slot | microSD (SDHC and SDXC (up to 128 GB)) SDHC Speed class 4 supported nanoSIMx2 DSDV (4Gx4G) | | |
| Microphone receiver | Attached ⁵ | | |
| Speaker | 90dB or more at 10 cm distance (at 2.8kHz) | | |
| Sensor | G-sensor, gyro sensor, proximity sensor, light intensity sensor, and geomagnetic sensor | | |
| Power supply | Main battery | Lithium-ion battery: 4,020mAh / 5,800mAh | |
| | Wireless charging | Supported (excl. battery and charger) | |
| | Quick charging | Supported (Quick charge 3.0) | |
| | Operating time ⁸ | 2,900 mAh battery: 14 h ⁹ / 4,020 mAh battery: 20 h ⁹ / 5,800 mAh battery: 29 h ⁹ | |
| Environmental requirements | Operating temperature ⁶ | -20°C to 50°C | |
| | Operating humidity | 20 to 80%RH (non-condensing and non-icing) | |
| | Protection rating ⁷ | IP65 / IP67 | |
| | Drop resistance ⁷ | 60 or more drops from 1.5 m, 3.0 m | |
| Weight (incl. battery) | ca. 365g (incl. BT1) / ca. 395g (incl. BT1L) | | |

¹ The LCD display is manufactured with precise technology. The rate of non-defective pixels is 99.99% or more, which means that 0.01% or less pixels could be stuck or dead.

² License is required.

³ Dragontrail® Pro is a registered trademark of AGC Inc.

⁴ Before using the NFC function, perform test reading sufficiently using the target NFC card.

⁵ A headset or headphone can be connected through the USB Type-C cable. A USB Type-C-to-audio jack (3.5 mm) conversion cable is optional.

⁶ 0°C to 40°C during charging.

⁷ These are the values tested at a room temperature, and not guaranteed values.

⁸ The operating time is a reference value at a room temperature and may differ depending on the operating conditions.

⁹ This is a result of measurement based on the JEITA HT Standard Operation Mode G, and may change depending on the operating environment and system settings.

ACCESSORIES (sold separately)

Communication / Charger

- USB type charger CU-M80U
- USB type charger CU-M80UQ (CQ3.0)
- Charger CU-M80L
- 4 slot unit charger CH-M80-4
- 4 slot battery charger CH-BT1-4
- AC adaptor
- AC adaptor (CQ3.0)

Batteries

- BT1 (4020 mAh)
- BT1L (5800 mAh)
- BT1S-W Wireless (2900 mAh)

Others

- Hand strap, waist case, stylus pen
- USB Type-C conversion cable (1.5m)

SOFTWARE

- SDK
- Scan Settings
- BHT Browser
- BHT Link
- BHT Setting
- BHT DMS
- Battery Monitor
- WLAN Manager
- BHT Remote
- Application Launcher
- BHT Security Package

DIMENSIONS

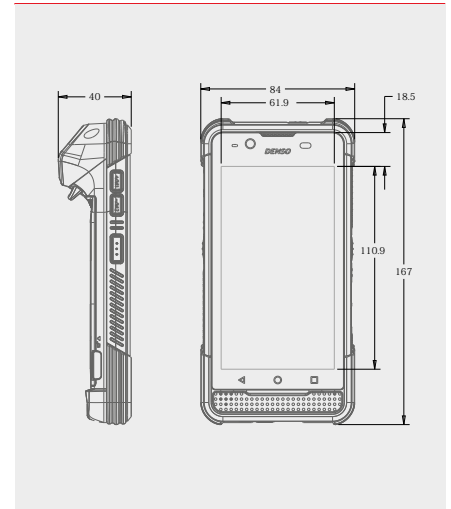

CDG Computer Peripheral and Supplies Ltd. บริษัท คอมพิวเตอร์เพิ่รณและสื่อบริการ (CDG Group) จำกัด

244 Soi Pattanakarn 53, Pattanakarn, Suanluang, Bangkok 10250 Thailand

Tel : (66) 0-2322-9535, 0-2722-4040
Fax : (66) 0-2322-7990
Mail : sales.dept@cps.co.th

For more information, please visit our website
www.cps.co.th
www.facebook.com/cps.co.th

TO USE THIS PRODUCT SAFELY

Before using this product, read its User's Manual thoroughly.

QR Code is a registered trademark of DENSO WAVE INCORPORATED.

Product appearance and specifications are subject to change without notice. | © 2020 DENSO WAVE EUROPE GmbH