



## Swing gate A315

Elegance design of of robust stain steel body with full stainless steel, the swing gate A315 is ideal choice for the most demanding building entrances.

With extra wide passage--900mm, A315 is comfortable and secure access to wheelchairs, large luggage or trollies have been carefully considered to ensure everyone – able and disabled have equally pleasing passage through out gates. (ADA access compliant passage width).

### OPERATING MODES

- Single passage in the set direction
- Bi-directional single passage
- Free passage in the set direction
- Always free or locked

### MATERIALS

- Housing:SUS 304 surface Hairline 400
- Top Cover: 2.0mm SUS304 mirror surface
- Arm:φ25mm full stainless steel

### FEATURES AND BENEFITS

- Space-saving, compact and modern design, the ideal choice for sites where limited space is available.
- Whisper quiet, low noise operation.
- Allows to integrate additional equipment, both as a built-it and with the external fixation.
- The swing gate should open automatically in the event of power failure on safety grounds. It makes it easier to evacuate people in case of emergency.
- Automatically reset : lock automatically while the pedestrian not pass the lane in the pre-set time after the flap opened. The passing time is adjustable.
- Configured with high-quality DC brushless motor and high-performance encoder imported. It carries servo control system, advanced motor control technology and precise positioning technology, to truly achieve precise control and stable performance, improve the opening & closing speed and throughput rate.
- Equipment developed with an eye on user safety and security, without exposed screws or sharp edges to prevent accidents
- With optimized mechanical structure design, it has higher fatigue resistance and impact resistance. It can ensure high stability when the turnstile is working under extra high traffic, and maintain its long-term normal operation.

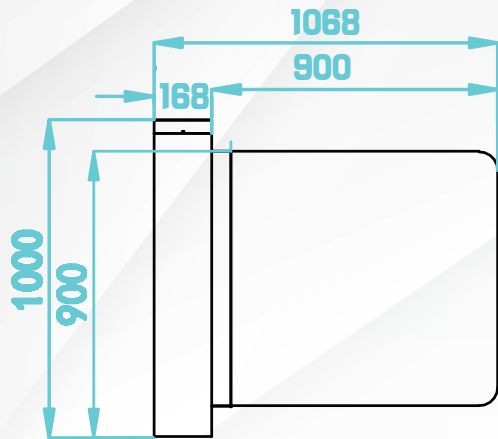

Technical Data	Unit	A315
Passage width	mm	≤900
Throughput rate	p/m	35-40
Input	100-240V;50/60HZ	
Operational voltage	V/(dc)	24
Drive Unit	Brushless Servo motor	
MCBF	cycle	5,000,000 Cycles
Operating time	second	0.2
Communication interface	RS485,Dry contact	
Dimension excluding bars	mm	Φ168*1000
Net weight including bars	Kg	40

## Project Cases

