

FLENDER COUPLINGS
CATALOG **FLE 10.2**
EDITION 2024 EN



FLEXIBLE COUPLINGS
N-EUPEX, RUPEX AND N-BIPEX

FLEXIBLE COUPLINGS



Catalog FLE 10.2 Edition 2024 EN

Introduction

Torsionally Rigid Gear Couplings

ZAPEX ZW

ZAPEX ZN

Torsionally Rigid All-Steel Couplings

N-ARPEX, ARPEX

Flexible Couplings

N-EUPEX

RUPEX

N-BIPEX

Highly Flexible Couplings

ELPEX-B

ELPEX-S

ELPEX

Fluid Couplings

FLUDEX

Backlash-free Couplings

SIPEX

BIPEX-S

Appendix

E

4

5

6

7

8

9

10

11

12

13

14

15

A

FLE 10 CATALOG GROUP



Product catalog FLE 10.1
FLEX-C10001-00-7600
Torsionally Rigid Couplings



Product catalog FLE 10.3
FLEX-C10003-00-7600
Highly Flexible Couplings



Product catalog FLE 10.2
FLEX-C10001-00-7600
Flexible Couplings



Product catalog FLE 10.4
FLEX-C10004-00-7600
Fluid Couplings

For further coupling catalogs, see page A/6

FLENDER COUPLINGS
CATALOG **FLE 10.5**
EDITION EN



HIGH PERFORMANCE COUPLINGS
ARPEX

flender.com

FLENDER

Product catalog FLE 10.5
FLEX-C10120-00-7600
High Performance Couplings

FLENDER-COUPLINGS
CATALOG **FLE 10.7**
EDITION EN



SAFETY COUPLINGS
ARPEX

flender.com

FLENDER

Product catalog FLE 10.7
FLEX-C10122-00-7600
Safety couplings

FLENDER COUPLINGS
CATALOG **FLE 10.6**
EDITION EN



BACKLASH-FREE COUPLINGS
SIPEX AND BIPEX-S

flender.com

FLENDER

Product catalog FLE 10.6
FLEX-C10121-00-7600
Backlash-free couplings

FLENDER CLAMPING ELEMENTS
CATALOG **FLE 10.8**
EDITION EN



CLAMPING ELEMENTS
FASTEX

flender.com

FLENDER

Product catalog FLE 10.8
FLEX-C10152-7600
Clamping elements

INTRODUCTION

E

The mechanical drive train comprises individual units such as motor, gear unit and driven machine. The coupling connects these component assemblies.

As well as the transmission of rotary motion and torque, other requirements may be made of the coupling.

- Compensation for shaft misalignment with low restorative forces
- Control of characteristic angular vibration frequency and damping
- Interruption or limitation of torque
- Noise insulation, electrical insulation

Couplings are frequently chosen after the machines to be connected have already been selected. Thanks to a large number of different coupling assembly options, specified marginal conditions for clearance and connection geometry can be met from the standard range. The coupling also performs secondary functions, e.g. providing a brake disk or brake drum for operating or blocking brakes, devices to record speed or the attachment of sprockets or pulleys.

Couplings are divided into two main groups, couplings and clutches.

Clutches interrupt or limited the transmissible torque. The engaging and disengaging forces on externally operated clutches are introduced via a mechanically, electrically, hydraulically or pneumatically operating mechanism. Overload, centrifugal or freewheel clutches draw their engaging energy from the transmitted output.

Rigid couplings, designed as clamp, flanged or mechanism couplings, connect machines which must not undergo any shaft misalignment. Hydrodynamic couplings, often also called fluid or Föttinger couplings, are used as starting couplings in drives with high mass moments of inertia of the driven machine. In drive technology very often flexible, positive couplings, which may be designed to be torsionally rigid, torsionally flexible or highly flexible, are used.

Torsionally rigid couplings are designed to be rigid in a peripheral direction and flexible in radial and axial directions. The angle of rotation and torque are conducted through the coupling without a phase shift.

Torsionally flexible couplings have resilient elements usually manufactured from elastomer materials. Using an elastomer material with a suitable ShoreA hardness provides the most advantageous torsional stiffness and damping for the application. Shaft misalignment causes the resilient elements to deform.

Highly flexible couplings have large-volume (elastomer) resilient elements of low stiffness. The angle of rotation and torque are conducted through the coupling with a considerable phase shift.

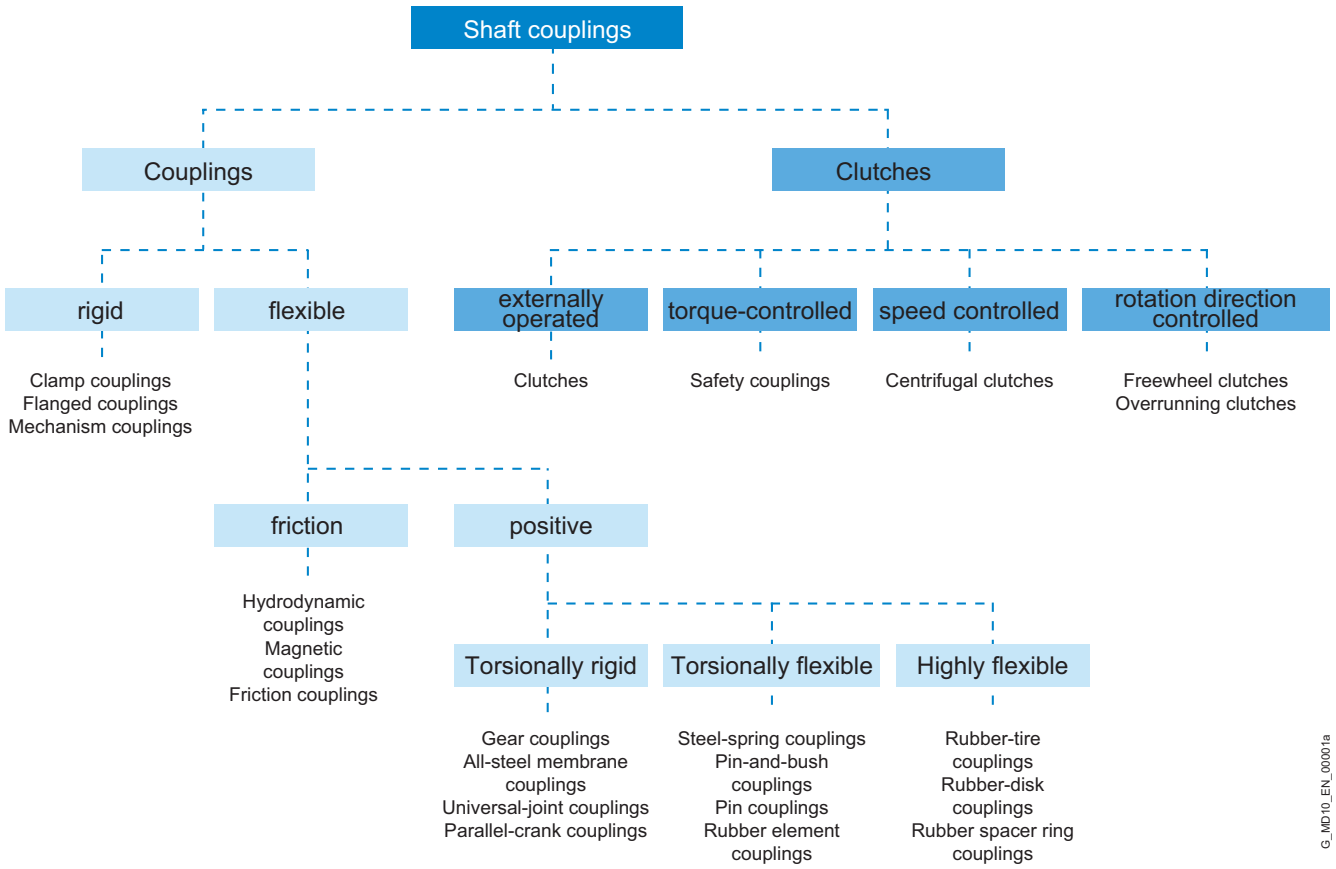

G_MD10_EN_00001a

OUR COUPLING GROUPS AT A GLANCE

E

N-EUPEX, RUPEX and N-BIPEX

Flexible Couplings

Flexible Flender couplings have a wide range of possible applications. A broad standard modular system as well as specially designed application-specific couplings are available.

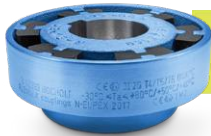

AIQ
Detect
ready

N-EUPEX
cam couplings
Rated torque:
12 Nm ... 93,500 Nm

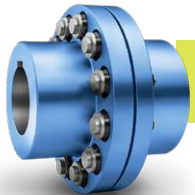

AIQ
Detect
ready

RUPEX
pin-and-bush couplings
Rated torque:
120 Nm ... 1,690,000 Nm



N-BIPEX
cam couplings
Rated torque:
12 Nm ... 4,650 Nm

ELPEX, ELPEX-B and ELPEX-S

Highly Flexible Couplings

ELPEX® couplings are free of circumferential back-lash. Their damping capacity and low torsional stiff-ness make them especially well-suited for coupling machines with strongly non-uniform torque characteristics or large shaft misalignment.



ELPEX
elastic ring couplings
Rated torque:
1,600 Nm ... 90,000 Nm



ELPEX-B
elastic tire couplings
Rated torque:
57 Nm ... 19,000 Nm



ELPEX-S
rubber disk couplings
Rated torque:
200 Nm ... 63,000 Nm

ZAPEX gear couplings and ARPEX all-steel couplings

Torsionally rigid couplings

For transmission of high torques, we offer both ARPEX all-steel couplings and ZAPEX gear couplings in a range of versions. Their purposes of application vary according to specific requirements with respect to shaft misalignment, temperature and torque.

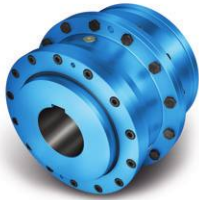

ZAPEX
gear couplings
Rated torque:
1,020 Nm ... 7,200,000 Nm



ARPEX
high Performance Couplings
Rated torque:
1,100 Nm ... 936,000 Nm



N-ARPEX and ARPEX
all-steel couplings
Rated torque:
92 Nm ... 2,000,000 Nm

BIPEX-S and SIPEX

Backlash-free couplings

The vibration-damping, electrically insulating plug-in BIPEX-S elastomer couplings and SIPEX metal bellows couplings with very high torsional stiffness deliver especially isogonal torque transmission.



BIPEX-S and SIPEX
Rated torque:
0.1 Nm ... 5,000 Nm

FLUDEX

Hydrodynamic couplings

The FLUDEX hydrodynamic fluid coupling works according to the Föttinger principle. It functions entirely free of wear.



FLUDEX
fluid Couplings
Power:
1.2 kW ... 2,500 kW

Application-specific couplings

Couplings for rail vehicles must meet high demands. Due to their high degree of standardization and wide variety, they can be used in the most diverse vehicle types.



Railway coupling
Rated torque:
1,000 Nm ... 9,500 Nm

Each wind turbine coupling is designed to optimally meet the requirements of the respective wind turbine. The coupling connects the fast-running gear shaft with the generator shaft and is available for wind turbines with a capacity of up to 12 MW.



Wind turbine couplings
Rated torque:
10,000 Nm ... 60,000 Nm

AIQ DETECT

for wear detection on the N-EUPEX and RUPEX

E

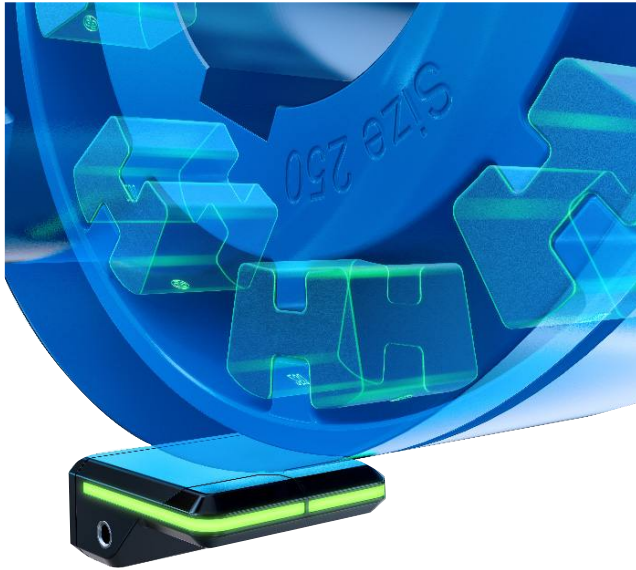

The AIQ Detect uses several Hall sensors to determine the wear on the flexible Flender couplings of the N-EUPEX and RUPEX via sensor magnets installed on the coupling side. The progressive wear of the elastomer components of the RUPEX and N-EUPEX results in a torsion angle between the coupling halves. This angle of rotation and the resulting time difference between the coupling halves make it possible to detect the degree of wear of the RUPEX and N-EUPEX flexible couplings. The speed of the coupling is also determined.

This information can be evaluated in the customer's control system via analogue and digital outputs that can be configured by the customer. The AIQ Detect also enables the wear status to be output via the built-in LED light strip on the sensor (green = the wear status is OK, yellow = the elastomer components must be replaced, red = the drivetrain must be stopped). This information can also be analyzed and displayed via a Bluetooth interface with a mobile device using the AIQ app.

Benefits:

- Continuous wear monitoring
- Coupling status at a glance
- Prevents system failures = maximum operational reliability
- Supports service and maintenance personnel
- Waste reduction (replacement of elastomers only if necessary)
- No annual testing of elastomers necessary
- Flexible and easy to use

Functions:

- Detects wear on elastomers
- Speed measurement
- Remaining life forecast
- Coupling failure detection
- Configurable output signals
- Firmware upgrades via AIQ app

Coupling	Types	Size	Article No.
N-EUPEX	A, B, B with clamping elements, H	80 – 140	F2E01528467
		160 – 280	F2E01528468
		315 – 710	F2E01528469
RUPEX	RWN, RWS	105 – 1120	F2E01528472
		1250 – 2000	F2E01528473

Notes

- The AIQ Detect is used for continuous wear monitoring of Flender N-EUPEX and RUPEX couplings and can be ordered as an accessory to the coupling
- Make sure that the Flender coupling has the 'AIQ Detect-ready' status (see ordering example)

Ordering example

- N-EUPEX coupling A, size 110 with the status "AIQ Detect-ready" (Article No. addition A99)
- AIQ Detect for wear monitoring of N-EUPEX coupling A, size 110

Article No. N-EUPEX: 2LC0170-4AB99-0AA0-Z L0M+M0P+A99

Article No. AIQ Detect: F2E01528467 (according to the table)

TECHNICAL INFORMATION AND COUPLING SELECTION

E

Technical Information	E/12
Shaft misalignment	E/12
Balancing	E/13
Shaft-hub connections	E/15
Standards	E/16
Key to symbols	E/17
<hr style="border-top: 1px dashed #0070C0;"/>	
Selection of the coupling series	E/18
Typical coupling solutions for different example applications	E/19
<hr style="border-top: 1px dashed #0070C0;"/>	
Selection of the coupling size	E/20
Coupling load in continuous operation	E/20
Coupling load at maximum and overload conditions	E/21
Coupling load due to dynamic torque load	E/21
Checking the maximum speed	E/22
Checking permitted shaft misalignment	E/22
Checking bore diameter, mounting geometry and coupling design	E/22
Coupling behavior under overload conditions	E/22
Checking shaft-hub connection	E/22
Checking low temperature and chemically aggressive environment	E/22
<hr style="border-top: 1px dashed #0070C0;"/>	
Features of the standard type	E/23
<hr style="border-top: 1px dashed #0070C0;"/>	

TECHNICAL INFORMATION

E

Shaft misalignment

Shaft misalignment is the result of displacement during assembly and operation and, where machines constructed with two radial bearings each are rigidly coupled, will cause high loads being placed on the bearings. Elastic deformation of base frame, foundation and machine housing will lead to shaft misalignment which cannot be prevented, even by precise alignment.

Furthermore, because individual components of the drive train heat up differently during operation, heat expansion of the machine housings causes shaft misalignment. Poorly aligned drives are often the cause of seal, rolling bearing or coupling failure. Alignment should be carried out by specialist personnel in accordance with operating instructions.

Depending on the direction of the effective shaft misalignment a distinction is made between:

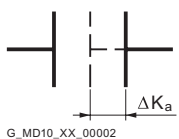

Axial misalignment

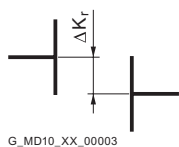

Radial misalignment

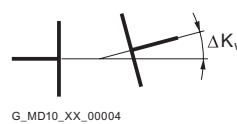

Angular misalignment

Couplings can be categorized into one of the following groups:

Single-joint couplings

Couplings with flexible elements mainly made of elastomer materials. Shaft misalignment results in deformation of the elastomer elements. The elastomer elements can absorb shaft misalignment as deformations in an axial, radial and angular direction. The degree of permissible misalignment depends on the coupling size, the speed and the type of elastomer element. Single-joint couplings do not require an adapter and are therefore short versions.

Example:

In the case of a RUPLEX RWN 198 coupling with an outer diameter of 198 mm and a speed of 1500 rpm, the permitted radial misalignment is $\Delta K_r = 0.3$ mm.

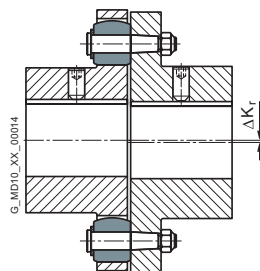

Two-joint couplings

Two-joint couplings are always designed with an adapter. The two joint levels are able to absorb axial and angular misalignment. Radial misalignment occurs via the gap between the two joint levels and the angular displacement of the joint levels. The permitted angular misalignment per joint level is frequently about 0.5°. The permitted shaft misalignment of the coupling can be adjusted via the length of the adapter. If there are more than two joint levels, it is not possible to define the position of the coupling parts relative to the axis of rotation. (The less frequently used parallel-crank couplings are an exception).

Example:

N-ARPEX ARN-6 NEN 217-6 with a shaft distance of 140 mm with a permitted radial misalignment of $\Delta K_r = 2.2$ mm [angle per joint level 1.0°].

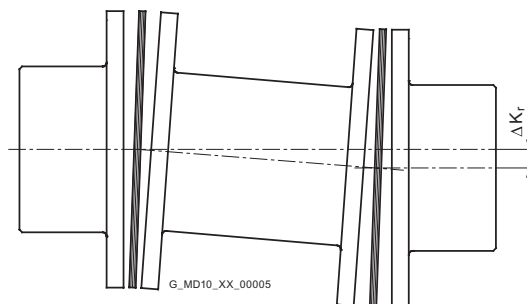

Balancing

Balance quality levels

The so-called quality level G to DIN ISO 21940 indicates a range of permitted residual imbalance from zero up to an upper limit. Applications can be grouped on the basis of similarity analysis. For many applications a coupling balance quality of G 16 is sufficient. On drives susceptible to vibration the balance quality should be G 6.3. Only in special cases is a better balance quality required.

Balancing standard in accordance with DIN ISO 21940-32

Besides the required balance quality, it is necessary to set standards which define how the mass of the parallel key is to be taken into consideration when balancing. In the past, motor rotors have frequently been balanced in accordance with the full parallel key standard. The "appropriate" balance condition of the coupling hub was described as "balancing with open keyway" or "balancing after keyseating". Today it is usual for the motor rotor, as well as the gear unit and driven machine shaft, to be balanced in accordance with the half parallel key standard.

Full parallel key standard

The parallel key is inserted in the shaft keyway, then balancing is carried out. The coupling hub must be balanced without parallel key after keyseating.

Marking of shaft and hub with "F" (for "full").

Half parallel key standard

The balancing standard normally applied today. Before balancing, a half parallel key is inserted in the shaft and another in the coupling hub. Alternatively, balancing can be carried out before cutting the keyway.

The balanced parts must be marked with an "H". This marking can be dispensed with if it is absolutely clear which parallel key standard has been applied.

No parallel key standard

Balancing of shaft and coupling hub after keyseating, but without parallel key. Not used in practice. Marking of shaft and hub with "N" (for "no").
The length of the parallel key is determined by the shaft keyway. Coupling hubs may be designed considerably shorter than the shaft.

To prevent imbalance forces caused by projecting parallel key factors when balancing in accordance with the half parallel key standard in the case of applications with high balancing quality requirements, grooved spacer rings can be fitted or stepped parallel keys used.

Flender Balancing Standard

The balancing quality level, together with the operating speed, results in the maximum permissible eccentricity of the center of gravity of the coupling or the coupling subassembly. In the Flender article number the balancing quality can be preset with the help of the order code. Additionally, also the balance quality level to DIN ISO 21940 can be preset together with the operating speed belonging to it, which then be taken as priority.

$$e_{perm} = 9550 \cdot \frac{G}{n}$$

$$e_{coupl} \leq e_{perm}$$

Permitted eccentricity of center of gravity e_{perm} in μm
 Eccentricity of center of gravity of coupling e_{coupl} in μm
 Balancing quality level G in mm/s
 Coupling speed n in rpm

Eccentricity of center of gravity of coupling e_{coupl}	Flender balancing quality	Order code
maximum 100 μm	standard balancing	without specification
maximum 40 μm	fine balancing	W02
maximum 16 μm	micro-balancing	W03
better than 16 μm	special balancing	on request

TECHNICAL INFORMATION

E

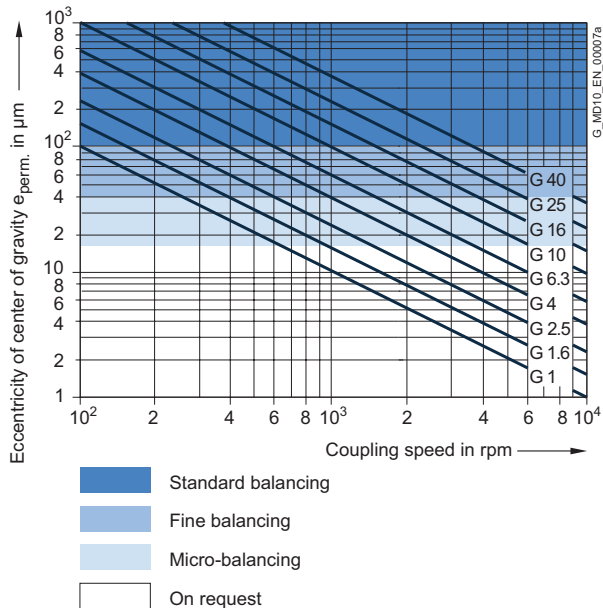

Example:
Coupling speed = 1450 rpm
required balancing quality level G 6.3

$$e_{perm} = 9550 \cdot \frac{G}{n} = 9550 \cdot \frac{6.3}{1450} \mu\text{m}$$

Thus, the required eccentricity of center of gravity is 41.5 µm. The fine balancing with a maximum eccentricity of center of gravity of 40 mm fulfills this requirement; therefore, the order code W02 has to be specified when ordering.

For many applications the following balancing quality recommendation applies:

Coupling	standard balancing $v = DA \cdot n/19100$	fine balancing
short version with $LG \leq 3 \times DA$	$v < 30 \text{ m/s}$	$v > 30 \text{ m/s}$
long version with $LG > 3 \times DA$	$v \leq 15 \text{ m/s}$	$v > 15 \text{ m/s}$

Peripheral speed	v	in mm/s
Coupling outer diameter	DA	in mm
Coupling speed	n	in rpm
Coupling length	LG	in mm

The following standards on balancing must be observed:

- couplings are balanced in subassemblies.
- hub parts without finished bore are unbalanced.
- the number of balancing levels (one- or two-level balancing) is specified by Flender.
- without special specification balancing is done in accordance with the half-parallel-key standard. Balancing in accordance with the full-parallel-key standard must be specified in the order number.
- For FLUDEX couplings special balancing standards specified in Section 13 apply.
- ARPEX couplings in standard balancing quality are unbalanced. Thanks to steel components machined all over and precisely guided adapters the balancing quality of standard balancing is nearly always adhered to.

Shaft-hub connections

The bore and the shaft-hub connection of the coupling are determined by the design of the machine shaft. In the case of IEC standard motors, the shaft diameters and parallel key connections are specified in accordance with DIN EN 50347. For diesel motors, the flywheel connections are frequently specified in accordance with SAE J620d or DIN 6288. Besides the very widely used connection of shaft and hub with parallel keys to DIN 6885 and cylindrically bored hubs, couplings with Taper clamping bushes, clamping sets, shrink-fit connections and splines to DIN 5480 are common.

The form stability of the shaft/hub connection can only be demonstrated when shaft dimensions and details of the connection are available. The coupling torques specified in the tables of power ratings of the coupling series do not apply to the shaft-hub connection unrestrictedly.

In the case of the shaft-hub connection with parallel key, the coupling hub must be axially secured, e.g. with a set screw or end washer. The parallel key must be secured against axial displacement in the machine shaft.

All Flender couplings with a finished bore and parallel keyway are designed with a set screw. Exceptions are some couplings of the FLUDEX series, in which end washers are used. During assembly, Taper clamping bushes are frictionally connected to the machine shaft.

TECHNICAL INFORMATION

E

Standards

Machines

2006/42/EG	EC Machinery Directive
2014/34/EU	ATEX Directive – Manufacturer
1999/92/EG	ATEX Directive – Operator – and ATEX Guideline to Directive 1999/92/EC
DIN EN 80079-36	Non-electrical equipment for use in potentially explosive atmospheres
DIN EN 1127	Explosive atmospheres, explosion prevention and protection
DIN EN 50347	General-purpose three-phase induction motors having standard dimensions and outputs

Couplings

DIN 740	Flexible shaft couplings Part 1 and Part 2
VDI Guideline 2240	Shaft couplings - Systematic subdivision according to their properties VDI Technical Group Engineering Design 1971
API 610	Centrifugal Pumps for Petroleum, Chemical and Gas Industry Services
API 671	Special Purpose Couplings for Petroleum, Chemical and Gas Industry Services
ISO 10441	Petroleum, petrochemical and natural gas industries – Flexible couplings for mechanical power transmission-special-purpose applications
ISO 13709	Centrifugal pumps for petroleum, petrochemical and natural gas industries

Balancing

DIN ISO 21940	Requirements for the balancing quality of rigid rotors
DIN ISO 21940-32	Mechanical vibrations; standard governing the type of parallel key during balancing of shafts and composite parts

Shaft-hub connections

DIN 6885	Driver connections without taper action – parallel keys – keyways
SAE J620d	Flywheels for industrial engines ...
DIN 6288	Reciprocating internal combustion engines Dimensions and requirements for flywheels and flexible couplings
ASME B17.1	Keys and keyseats
DIN EN 50347	General-purpose three-phase induction motors with standard dimensions and output data
BS 46-1:1958	Keys and keyways and taper pins Specification

Key to symbols

Name	Symbols	Unit	Explanation
Torsional stiffness, dynamic	C_{Tdyn}	Nm/rad	For calculating torsional vibration
Excitation frequency	f_{err}	Hz	Excitation frequency of motor or driven machine
Moment of inertia	J	kgm ²	Moment of inertia of coupling sides 1 and 2
Axial misalignment	ΔK_a	mm	Axial misalignment of the coupling halves
Radial misalignment	ΔK_r	mm	Radial misalignment of the coupling halves
Angular misalignment	ΔK_w	°	Angular misalignment of the coupling halves
Service factor	FB		Factor expressing the real coupling load as a ratio of the nominal coupling load
Frequency factor	FF		Factor expressing the frequency dependence of the fatigue torque load
Temperature factor	FT		Factor taking into account the reduction in strength of flexible rubber materials at a higher temperature
Weight	m	kg	Weight of the coupling
Rated speed	n_N	rpm	Coupling speed
Maximum coupling speed	n_{Kmax}	rpm	Maximum permissible coupling speed
Rated power	P_N	kW	Rated output on the coupling, usually the output of the driven machine
Rated torque	T_N	Nm	Rated torque as nominal load on the coupling
Fatigue torque	T_W	Nm	Amplitude of the dynamic coupling load
Maximum torque	T_{max}	Nm	More frequently occurring maximum load, e.g. during starting
Overload torque	T_{OL}	Nm	Very infrequently occurring maximum load, e.g. during short circuit or blocking conditions
Rated coupling torque	T_{KN}	Nm	Torque which can be transmitted as static torque by the coupling over the period of use.
Maximum coupling torque	T_{Kmax}	Nm	Torque which can be frequently transmitted (up to 25 times an hour) as maximum torque by the coupling.
Coupling overload torque	T_{KOL}	Nm	Torque which can very infrequently be transmitted as maximum torque by the coupling.
Fatigue coupling torque	T_{KW}	Nm	Torque amplitude which can be transmitted by the coupling as dynamic torque at a frequency of 10 Hz over the period of use.
Resonance factor	V_R		Factor specifying the torque increase at resonance
Temperature	T_a	°C	Ambient temperature of the coupling in operation
Damping coefficient	Ψ	psi	Damping parameter

SELECTION OF THE COUPLING SERIES

E

The coupling series is frequently determined by the driven machine and the design of the drive train. Common selection criteria are listed below and assigned to coupling properties, which are used to select the coupling series. Additionally, the price of the coupling and availability are important criteria for determining the coupling series to be used.

The **FLUDEX series** operates positively and transmits the torque with the aid of a flowing oil or water filling.

FLUDEX couplings are used to reduce starting and/or overload torques. During starting, the motor may, for example, run up within a very short time; because of the FLUDEX coupling, the drive train with the driven machine may accelerate after a delay and without increased torque load.

The FLUDEX coupling cannot compensate for shaft misalignment and is therefore designed in combination with a displacement coupling, a cardan shaft or a belt drive. The displacement coupling may be selected in accordance with the criteria described below.

Selection criteria						
	Torque range Rated coupling torque T_{KN}	Speed range Peripheral speed $v_{max} = DA \cdot n_{max}/19100$	Torsional stiffness		Highly flexible	Operating temperature range
			torsionally rigid	torsionally flexible		
ZAPEX	1020 ... 7200000 Nm	60 m/s	■	-	-	-20 ... +80 °C
N-ARPEX	350 ... 2000000 Nm	110 m/s	■	-	-	-50 ... +280 °C
N-EUPEX	12 ... 93500 Nm	36 m/s	-	■	-	-50 ... +100 °C
N-EUPEX DS	19 ... 21200 Nm	36 m/s	-	■	-	-30 ... +80 °C
RUPEX	120 ... 1690000 Nm	60 m/s	-	■	-	-50 ... +100 °C
N-BIPEX	12 ... 4650 Nm	45 m/s	-	■	-	-50 ... +120 °C
ELPEX-B	57 ... 19000 Nm	45 m/s	-	-	■	-50 ... +70 °C
ELPEX-S	200 ... 63000 Nm	66 m/s	-	-	■	-40 ... +120 °C
ELPEX	1600 ... 90000 Nm	60 m/s	-	-	■	-40 ... +80 °C

Typical coupling solutions for different example applications

The specified application factors are recommendations; regulations, rules and practical experience take priority as assessment criteria.

No application factor need be taken into account with FLUDEX couplings.

In the case of highly flexible couplings of the ELPEX, ELPEX-S and ELPEX-B series, deviating application factors are stated in the product descriptions. FLUDEX couplings are mostly mounted on the high-speed gear shaft.

Example applications	Application factor FB
Electric motor without gear unit	
Centrifugal pumps	1.0
Piston pumps	1.5
Vacuum pumps	1.5
Fans with T_N less than 75 Nm	1.5
Fans with T_N from 75 to 750 Nm	1.75
Fans with T_N larger than 750 Nm	1.75
Blowers	1.5
Frequency converters / generators	1.25
Reciprocating compressors	1.75
Screw-type compressors	1.5
Internal-combustion engine without gear unit	
Generators	1.75
Pumps	1.5
Fans	1.75
Hydraulic pumps, excavators, construction machines	1.5
Compressors / screw-type compressors	1.5
Agricultural machinery	1.75
Other	
Turbine gear units	1.5
Hydraulic motor - gear unit	1.25
Electric motor with gear unit	
Chemical industry	
Extruders	1.5
Pumps - centrifugal pumps	1.0
Pumps - piston pumps	1.75
Pumps - plunger pumps	1.5
Reciprocating compressors	1.75
Calenders	1.5
Kneaders	1.75
Cooling drums	1.25
Mixers	1.25
Stirrers	1.25
Toasters	1.25
Drying drums	1.25
Centrifuges	1.25
Crushers	1.5
Power generation and conversion	
Compressed air, reciprocating compressors	1.75

Example applications	Application factor FB
Compressed air, screw-type compressors	1.25
Air - Blowers	1.5
Air - Cooling tower fans	1.5
Air - Turbine blowers	1.5
Generators, converters	1.25
Welding generators	1.25
Metal production, iron and steel works	
Plate tilters	1.5
Ingot pushers	1.75
Slabbing mill	1.75
Coiling machines	1.5
Roller straightening machines	1.5
Roller tables	1.75
Shears	1.75
Rollers	1.75
Metal working machines	
Plate bending machines	1.5
Plate straightening machines	1.5
Hammers	1.75
Planing machines	1.75
Presses, forging presses	1.75
Shears	1.5
Grinding machines	1.25
Punches	1.5
Machine tools: Main drives	1.5
Machine tools: Auxiliary drives	1.25
Food industry	
Filling machines	1.25
Kneading machines	1.5
Mashers	1.5
Sugar cane production	1.5
Production machines	
Construction machines, hydraulic pumps	1.25
Construction machines, traversing gears	1.5
Construction machines, suction pumps	1.5
Construction machines, concrete mixers	1.5
Printing machines	1.25
Woodworking - barking drums	1.5
Woodworking - planing machines	1.5

Example applications	Application factor FB
Woodworking - reciprocating saws	1.5
Grinding machines	1.5
Textile machines - winders	1.5
Textile machines - printing machines	1.5
Textile machines - tanning vats	1.5
Textile machines - shredders	1.5
Textile machines - looms	1.5
Packaging machines	1.5
Brick molding machines	1.75
Transport and logistics	
Passenger transport - elevators	1.5
Passenger transport - escalators	1.5
Conveyor systems - bucket elevators	1.5
Conveyor systems - hauling winches	1.5
Conveyor systems - belt conveyors	1.5
Conveyor systems - endless-chain conveyors	1.5
Conveyor systems - circular conveyors	1.5
Conveyor systems - screw conveyors	1.5
Conveyor systems - inclined hoists	1.5
Crane traversing gear	1.5
Hoisting gear	1.5
Crane lifting gear	2.0
Crane traveling gear	1.5
Crane slewing gear	1.5
Crane fly jib hoists	1.5
Cable railways	1.5
Drag lifts	1.5
Winches	1.5
Cellulose and paper	
Paper-making machines, all	1.5
Pulper drives	1.5
Cement industry	
Crushers	1.75
Rotary furnaces	1.5
Hammer mills	1.75
Ball mills	1.75
Pug mills	1.75
Mixers	1.5
Pipe mills	1.5
Beater mills	1.75
Separators	1.5
Roller presses	1.75

SELECTION OF THE COUPLING SIZE

E

The torque load of the coupling must be determined from the output of the driven machine and the coupling speed.

Rated coupling load $T_N = 9550 \times P_N / n_N$
 (T_N in Nm; P_N in kW; n_N in rpm)

The rated coupling load obtained in this way must be multiplied by factors and compared with the rated coupling torque. An ideal but expensive method is to measure the torque characteristic on the coupling. For this, Flender offers special adapters fitted with torque measuring devices.

The rated coupling torque T_{KN} is the torque which can be transmitted by the coupling over an appropriate period of use if the load is applied to the coupling purely statically at room temperature.

Application factors are to express the deviation of the real coupling load from the "ideal" load condition.

Coupling load in continuous operation

The operating principles of the driving and driven machines are divided into categories and the application factor FB derived from these in accordance with DIN 3990-1.

Application factor for N-EUPEX, N-EUPEX-DS, RUPEX, N-BIPEX, ELPEX-B, N-ARPEX, ARPEX, ZAPEX and FLUDEX

Application factor FB				
Torque characteristic of the driving machine	Torque characteristic of the driven machine			
	uniform	uniform with moderate shock loads	non uniform	very rough
uniform	1.0	1.25	1.5	1.75
uniform with moderate shock loads	1.25	1.5	1.75	2.0
non uniform	1.5	1.75	2.0	2.5

Examples of torque characteristic of driving machines:

- uniform: Electric motors with soft starting, steam turbines
- uniform with moderate shock loads: Electric motors without soft starting, hydraulic motors, gas and water turbines
- non uniform: Internal-combustion engines

Examples of torque characteristic in driven machines:

- uniform: Generators, centrifugal pumps for light fluids
- uniform with moderate shock loads: Centrifugal pumps for viscous fluids, elevators, machine tool drives, centrifuges, extruders, blowers, crane drives
- non uniform: Excavators, kneaders, conveyor systems, presses, mills
- very rough: Crushers, excavators, shredders, iron/smelting machinery

Temperature factor FT												
Coupling	Elastomer material	Low temperature °C	Temperature T_a on the coupling									
			under -30 °C	-30 °C up to 50 °C	up to 60 °C	up to 70 °C	up to 80 °C	up to 90 °C	up to 100 °C	up to 110 °C	up to 120 °C	
N-EUPEX	NBR	-30	-	1.0	1.0	1.0	1.0	1.0	-	-	-	-
N-EUPEX	NR	-50	1.1 ¹⁾	1.0	-	-	-	-	-	-	-	-
N-EUPEX	HNBR	-10	-	1.0	1.0	1.0	1.0	1.0	1.25	1.25	-	-
N-EUPEX	TPU	-50	1.0	1.0	1.05	1.10	1.15	-	-	-	-	-
N-EUPEX DS	NBR	-30	-	1.0	1.0	1.0	1.0	-	-	-	-	-
RUPEX	NBR	-30	-	1.0	1.0	1.0	1.0	-	-	-	-	-
RUPEX	NR	-50	1.1	1.0	-	-	-	-	-	-	-	-
RUPEX	HNBR	-10	-	1.0	1.0	1.0	1.0	1.0	1.25	1.25	-	-
N-BIPEX	TPU	-50	1.0	1.0	1.0	1.0	1.0	1.0	1.0	1.3	1.5	-
ELPEX	NR	-40	1.1	1.0	1.25	1.40	1.60	-	-	-	-	-
ELPEX-B	NR	-50	1.1	1.0	-	-	-	-	-	-	-	-
ELPEX-B	CR	-15	-	1.0	1.0	1.0	-	-	-	-	-	-
ELPEX-S SN, NN, WN	NR	-40	1.1	1.0	1.25	1.40	1.60	-	-	-	-	-
ELPEX-S NX	VMQ	-40	1.1	1.0	1.0	1.0	1.0	1.1	1.25	1.4	1.6	-

- NR = natural rubber, natural-synthetic rubber mixture
- NBR = nitril-butadiene-rubber (Perbunan)
- HNBR = hydrated acrylonitrile butadiene rubber
- CR = chloroprene rubber (FRAS fire-resistant and anti-static)
- VMQ = silicone
- TPU = polyurethane

¹⁾ The N-EUPEX coupling is not suitable for shock loads when used at low temperatures.

Coupling size $T_{KN} \geq T_N \cdot FB \cdot FT$

In the case of ARPEX and ZAPEX coupling types, no temperature factor (FT = 1.0) need be taken into account.

Coupling load at maximum and overload conditions

The maximum torque is the highest load acting on the coupling in normal operation. Maximum torques at a frequency of up to 25 times an hour are permitted and must be lower than the maximum coupling torque. Examples of maximum torque conditions are: Starting operations, stopping operations or usual operating conditions with maximum load.

$T_{Kmax} \geq T_{Max} \cdot FT$

Overload torques are maximum loads which occur only in combination with special, infrequent operating conditions. Examples of overload torque conditions are: Motor short circuit, emergency stop or blocking because of component breakage. Overload torques at a frequency of once a month are permitted and must be lower than the maximum overload torque of the coupling. The overload condition may last only a short while, i.e. fractions of a second.

$T_{KOL} \geq T_{OL} \cdot FT$

Coupling load due to dynamic torque load

Applying the frequency factor FF, the dynamic torque load must be lower than the coupling fatigue torque.

Dynamic torque load

$T_{KW} \geq T_W \cdot FF$

Frequency of the dynamic torque load $f_{err} \leq 10$ Hz frequency factor FF = 1.0

Frequency of the dynamic torque load $f_{err} > 10$ Hz frequency factor FF = $\sqrt{(f_{err}/10 \text{ Hz})}$

For the ZAPEX and ARPEX series, the frequency factor is always FF = 1.0.

SELECTION OF THE COUPLING SIZE

E

Checking the maximum speed

For all load situations $n_{K_{max}} \geq n_{max}$

Checking permitted shaft misalignment

For all load situations, the actual shaft misalignment must be less than the permitted shaft misalignment.

Checking bore diameter, mounting geometry and coupling design

The check must be made on the basis of the dimension tables. The maximum bore diameter applies to parallel keyways to DIN 6885. For other keyway geometries, the maximum bore diameter can be reduced.

On request, couplings with adapted geometry can be provided.

Coupling behavior under overload conditions

The ZAPEX, N-ARPEX, ARPEX, N-EUPEX, RUPEX and N-BIPEX coupling series can withstand overloads until the breakage of metal parts. These coupling series are designated as fail-safe.

The N-EUPEX DS, ELPEX-B, ELPEX-S and ELPEX coupling series throw overload. The elastomer element of these couplings is irreparably damaged without damage to metal parts when subjected to excessive overload.

These coupling series are designated as non-fail-safe. These types that fail can be fitted with a so-called fail-safe device. This additional component enables emergency operation, even after the rubber element of the coupling has been irreparably damaged.

Checking shaft-hub connection

The torques specified in the tables of power ratings data of the coupling series do not necessarily apply to the shaft-hub connection. Depending on the shaft-hub connection, proof of form stability is required. Flender recommends obtaining proof of form strength by using calculation methods in accordance with the current state of the art.

Fitting recommendations for the shaft-hub connection are given in the **Appendix**.

The coupling hub is frequently fitted flush with the shaft end face. If the shaft projects, the risk of collision with other coupling parts must be checked. If the shaft is set back, in addition to the load-bearing capacity of the shaft-hub connection, the correct positioning of the hub must be ensured as well. If the bearing hub length is insufficient, restorative forces may cause tilting movements and so wear to and impairment of the axial retention. Also, the position of the set screw to be positioned on sufficient shaft or parallel key material must be noted.

Shaft-hub connection	Suggestion for calculation method
Keyway connection to DIN 6885-1	DIN 6892
Shrink fit	DIN 7190
Spline to DIN 5480	
Bolted flange connection	VDI 2230
Flange connection with close-fitting bolts	

Checking low temperature and chemically aggressive environment

The minimum permitted coupling temperature is specified in the Temperature factor FT table. In the case of chemically aggressive environments, please consult the manufacturer.

FEATURES OF THE STANDARD TYPE



Couplings	Features of the standard type
All coupling series except ARPEX clamping hubs and FLUDEX with keyway to ASME B17.1	Bore tolerance H7
N-ARPEX and ARPEX clamping hubs	Bore tolerance G6 (suitable for shaft tolerance h6)
FLUDEX couplings with keyway to ASME B17.1	Hollow shafts: bore tolerance K7 other parts: bore tolerance M7
All coupling series with bore diameter - imperial	Parallel keyway to ASME B17.1
Bore diameter metric in the case of ZAPEX, N-ARPEX and ARPEX coupling series as well as coupling hubs with applied brake disks or brake drums of the N-EUPEX and RUPEX series	Parallel keyway to DIN 6885-1 keyway width P9
Bore diameter metric in the case of the N-EUPEX, RUPEX, N-BIPEX, ELPEX-S, ELPEX-B, ELPEX, FLUDEX coupling series	Parallel keyway to DIN 6885-1 keyway width JS9
All coupling series except FLUDEX	Axial locking by means of set screw
FLUDEX coupling series	Axial lock by means of set screw or end washer
All coupling series	Balancing in accordance with half parallel key standard
ZAPEX, N-ARPEX, ARPEX, N-EUPEX, RUPEX, N-BIPEX, ELPEX-S, ELPEX-B and ELPEX coupling series	Balancing quality G16
FLUDEX coupling series	Balancing quality G6.3
SIPEX and BIPEX-S coupling series	Balancing quality G6.3 for 3600 rpm
All series	Unpainted
All series	Preservation with cleaning emulsion
FLUDEX couplings	Fuse 140 °C

Configurator

The article number can be obtained with the help of the Configurator. The coupling can be selected in a product configurator and specified using selection menus.

The coupling can be selected via "Technical selection" (technical selection) or via "Direct selection" (via article no.).

The Configurator is available under flender.com.

FLEXIBLE COUPLINGS – N-EUPEX, N-EUPEX DS SERIES

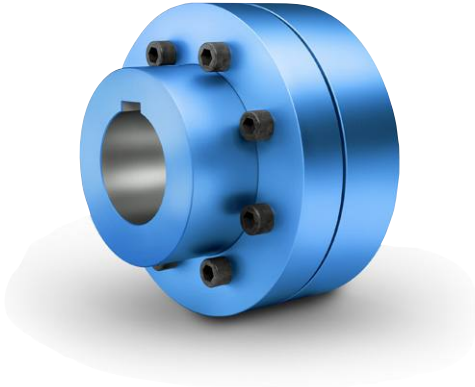

General	7/2
Benefits	7/2
Application	7/2
Design and configurations	7/3
Modular principle of N-EUPEX types	7/5
Technical specifications, N-EUPEX series	7/8
Assignment of N-EUPEX sizes to IEC standard motors	7/10
Type A for easy elastomer flexible replacement	7/11
Type B	7/12
Type B with clamping elements	7/13
Type DK for large misalignment with simple installation and removal	7/14
Type DKS	7/15
Type H	7/16
Type D for easy elastomer flexible replacement	7/18
Type E	7/20
Type P with brake drum	7/22
Type O with brake drum	7/24
Type DBDR with brake disk	7/26
Type ABD with brake disk	7/28
Type ERN with slip unit	7/29
N-EUPEX DS series	7/31
General	7/31
Technical specifications, N-EUPEX DS series	7/31
Type ADS for easy elastomer flexible replacement	7/32
Type BDS	7/33
Type HDS	7/34
Spare and wear parts	7/36



N-EUPEX
FLENDER

GENERAL



N-EUPEX as overload-holding, fail-safe series

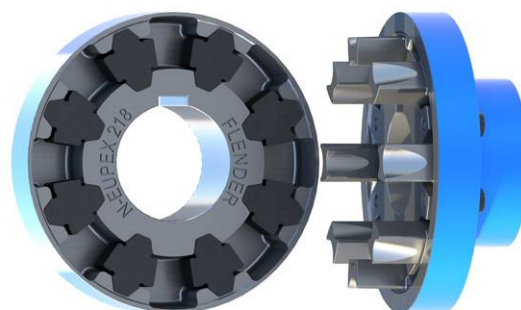

N-EUPEX DS as overload-shedding, non-fail-safe series

N-EUPEX and N-EUPEX DS pin couplings connect machines. They compensate for shaft misalignment, generating only low restorative forces. The torque is conducted through elastomer flexibles, so the coupling has typically flexible rubber properties.

N-EUPEX couplings are overload-holding. By contrast, the N-EUPEX DS series is designed so that overload or advanced wear causes irreparable damage to the elastomer flexibles. The metal parts of N-EUPEX DS couplings can then rotate freely against one another without contact.

Benefits

N-EUPEX couplings are designed on the modular principle and have a very simple construction. N-EUPEX types are made up of subassemblies to suit requirements. The couplings are assembled by simply fitting the coupling halves together. Wear is restricted to the elastomer flexibles, which must be replaced at the end of their service life.

Application

The N-EUPEX coupling is available as a catalog standard in 23 sizes with a rated torque of between 28 Nm and 71000 Nm. The coupling is suitable for ambient temperatures of between -30 °C and +80 °C. By using alternative elastomer flexibles, the permissible ambient temperature range can be extended to between -50 °C and +100 °C. Frequently, the coupling is used to connect the motor to the gear unit input shaft. The coupling is suitable especially for drives with uniform to average dynamic loads.



Coupling suitable for use in potentially explosive atmospheres.

Complies with the current ATEX Directive for:

CE  II 2G Ex h IIC T6 ... T4 Gb X

 II 2D Ex h IIIC T85 °C ... 110 °C Db X

 I M2 Ex h Mb X

Depending on type, the elastomer flexibles can be changed without moving the coupled machines. The coupling parts are readily available from stock and are mostly finish-machined, i.e. with finished bore, keyway, set screw and balancing.

Examples of applications are pump drives, ventilator drives or crane running gear. Furthermore, N-EUPEX couplings can be used as add-on couplings, particularly on FLUDEX fluid couplings or ARPEX AKR safety couplings. In the case of drives with a diesel engine, N-EUPEX couplings are suitable for driven machines with a low mass moment of inertia. In the case of diesel engine drives, the actual dynamic coupling load should be checked by measurement or torsional vibration calculations.

Design and configurations

N-EUPEX and N-EUPEX DS couplings consist of two coupling halves mounted on the machine shafts. The coupling parts are connected positively by means of elastomer flexibles. On the two-part variant, the elastomer flexibles can be changed only if one of the coupled machines is moved.

On the three-part variants, the bolted cam ring can be released and moved to enable the flexible to be changed without moving the coupled machines.

Elastomer flexible of the N-EUPEX series



The flexibles of the N-EUPEX coupling are subjected to compression. This results in progressive torsion spring characteristics. If the flexibles are irreparably damaged, the hub parts come into contact with metal. This causes the torque to continue to be transmitted in "emergency mode" for a short period of time.

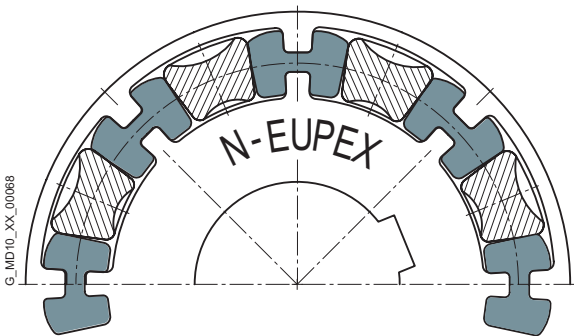

Elastomer flexible of the N-EUPEX DS series



The flexibles of the N-EUPEX DS series are subjected to compression and bending forces. A linear torsion spring characteristic curve is characteristic in this regard. If the flexibles are irreparably damaged, the metal parts turn against one another without contact, and the power transmission is separated. Fitting new flexibles will make the coupling once more usable. The capacity of the N-EUPEX DS series to shed overloads is especially in demand for highly sensitive machines.

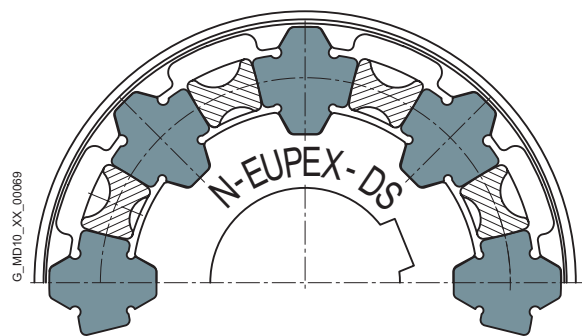

GENERAL

Materials

All coupling parts such as cam parts, pocket parts, spacers, hub parts and mounting parts are manufactured from high grade cast iron with lamellar or spheroidal graphite, or from steel. The sleeve pipes of the type DK spacers are made from aluminum.

Flexible materials

Material/description	Hardness	Marking	Ambient temperature
N-EUPEX series			
NBR standard type	80 ShoreA	Flexible black with blue stripe	-30 °C ... +80 °C
NBR electrically insulating	80 ShoreA	Flexible green	-30 °C ... +80 °C
NBR soft (size 225 to 710)	65 ShoreA	Flexible black with green stripe	-30 °C ... +80 °C
HP (TPU) (size 80 to 280)	97 ShoreA	Flexible blue	-50 °C ... +80 °C
HP (NBR) (size 315 to 710)	90 ShoreA	Flexible black, fabric reinforced	-30 °C ... +80 °C
HP (NBR) (size 58 to 68)	90 ShoreA	Flexible black with magenta stripe	-30 °C ... +80 °C
NBR normal low-backlash (size 58 to 200)	80 ShoreA	Flexible black with yellow stripe	-30 °C ... +80 °C
NBR soft low-backlash (size 58 to 200)	65 ShoreA	Flexible black with white stripe	-30 °C ... +80 °C
NR for low temperature	80 ShoreA	Flexible black with orange stripe	-50 °C ... +50 °C
HNBR high temperature	80 ShoreA	Flexible black with red stripe	-10 °C ... +100 °C
Type N-EUPEX DK/DKS			
HP (TPU) (size 80 to 280)	97 ShoreA	Flexible blue	-50 °C ... +80 °C
HP (NBR) (size 68)	90 ShoreA	Flexible black with magenta stripe	-30 °C ... +80 °C
N-EUPEX DS series			
NBR hard	90 ShoreA	Flexible black	-30 °C ... +80 °C

The technical data do not include the flexible variants NBR low-backlash, HNBR high temperature and NR low temperature. Technical data, prices and article numbers can be found at www.flender.com

Standard types of N-EUPEX and N-EUPEX DS pin coupling

Type	Description
A	Fail-safe, 3-part
B	Fail-safe, 2-part
D	Fail-safe, 3-part, flange variant
E	Fail-safe, 2-part, flange variant
DK	Fail-safe, double-cardanic, with spacer
DKS	Fail-safe, double-cardanic, short length
H	Fail-safe, with adapter
P	Fail-safe, 3-part, with brake drum
O	Fail-safe, 2-part, with brake drum
DBDR	Fail-safe, 3-part, with brake disk, brake disk radially dismountable
ABD	Fail-safe, 3-part, with brake disk
ERN	Fail-safe, 2-part, with slip unit
ADS	Non-fail-safe, 3-part
BDS	Non-fail-safe, 2-part
HDS	Non-fail-safe, with adapter

Special types of N-EUPEX pin coupling on request

Type	Description
AT	Fail-safe, 3-part, with Taper clamping bush
BT	Fail-safe, 2-part, with Taper clamping bush
F	Fail-safe, 3-part, with intermediate shaft
G	Fail-safe, 2-part, with intermediate shaft
K	Fail-safe, 3-part, with brake drum to customer's requirement
L	Fail-safe, 2-part, with brake drum to customer's requirement
M	Fail-safe, 2-part, with flange dimensions to SAE J620d
DBD	Fail-safe, 3-part, with brake disk
EBD	Fail-safe, 2-part, with brake disk

Further application-related coupling types are available. Dimension sheets for and information on these are available on request.

Modular principle of N-EUPEX types

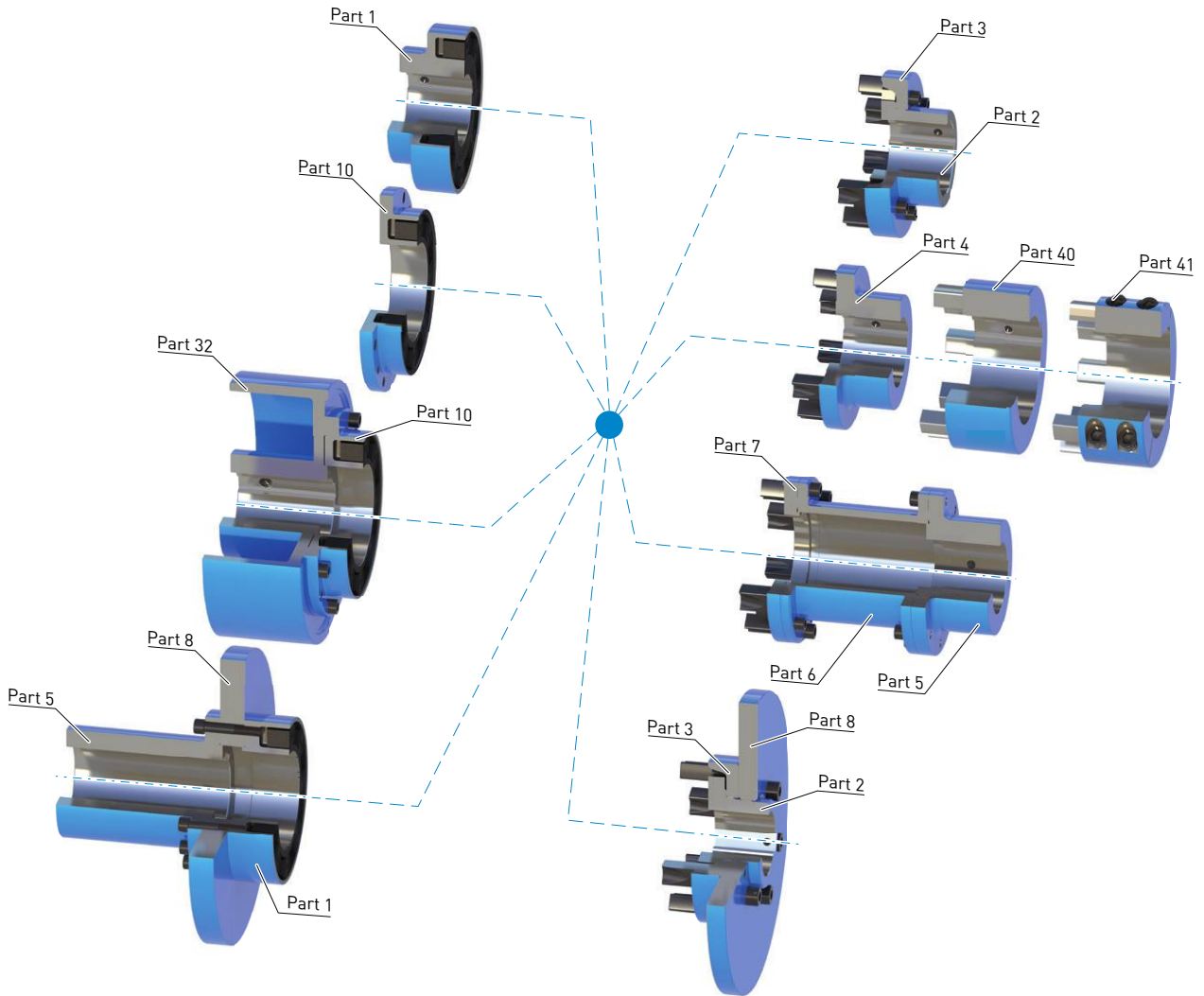

N-EUPEX DK/DKS

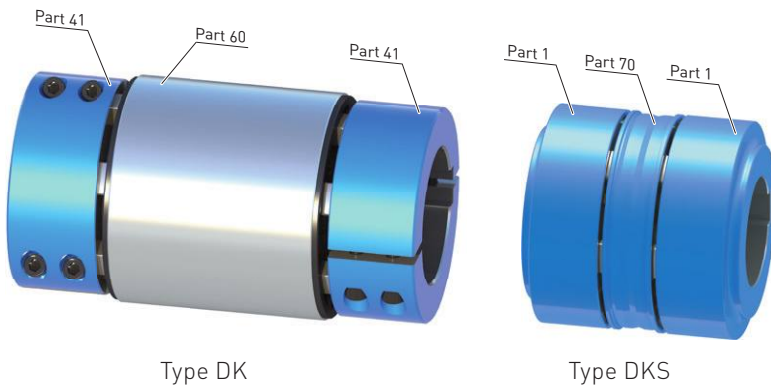

In the case of larger radial misalignment, double-cardanic N-EUPEX couplings can be supplied in addition to the modular system. The spacer (part 60 resp. 70) is centered with the help of the N-EUPEX elastomer elements. Any radial misalignment that emerges between the shaft ends will accordingly be equalized through a corresponding tilt angle in the elastomer joints with this two-joint versions. In the DK version, the separated hubs (part 41) made from steel facilitate simple installation. The DKS version is characterized by a reduced shaft distance.

GENERAL

Types N-EUPEX

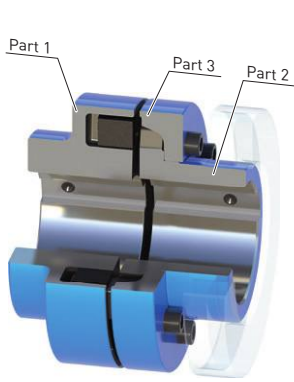

Types A and ADS

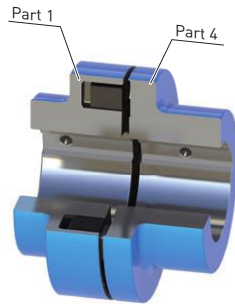

Types B and BDS

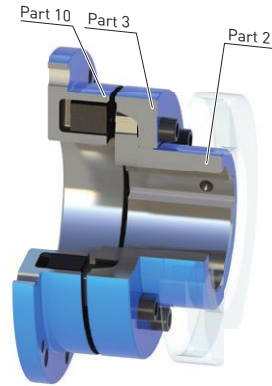

Type D

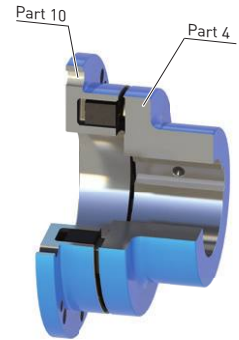

Type E

Types N-EUPEX with adapter

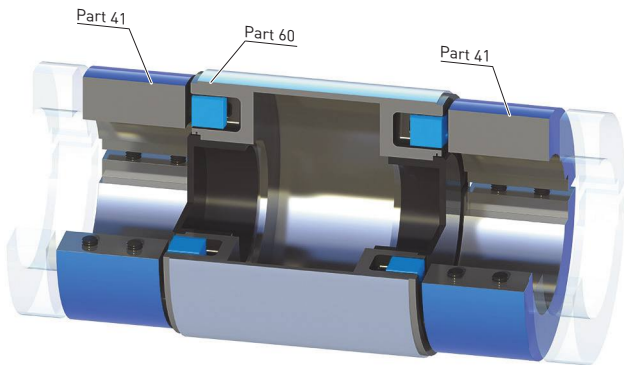

Type DK

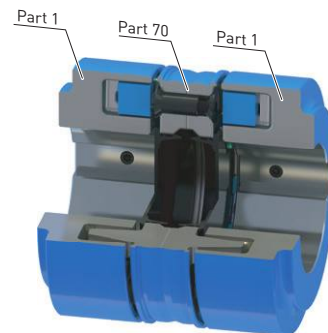

Type DKS

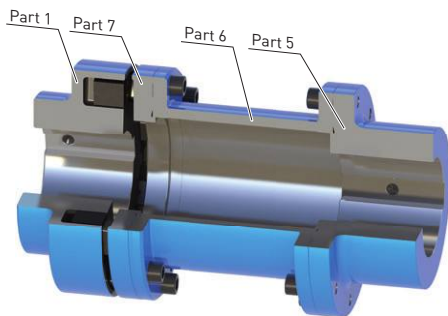

Types H and HDS

Type N-EUPEX with brake disk/brake drum

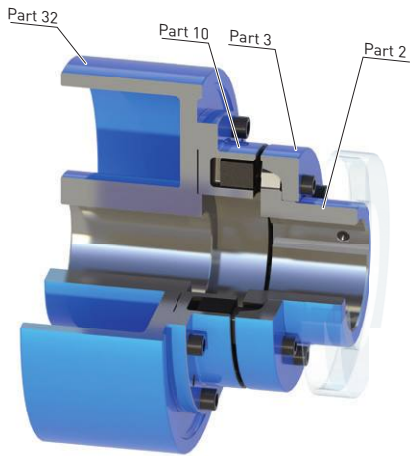

Type P

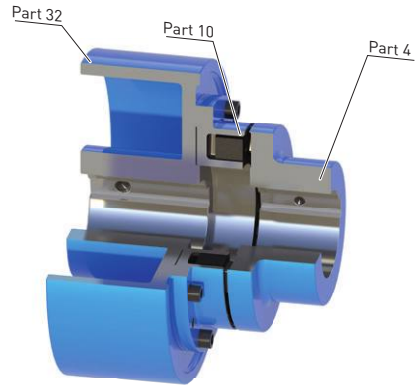

Type O

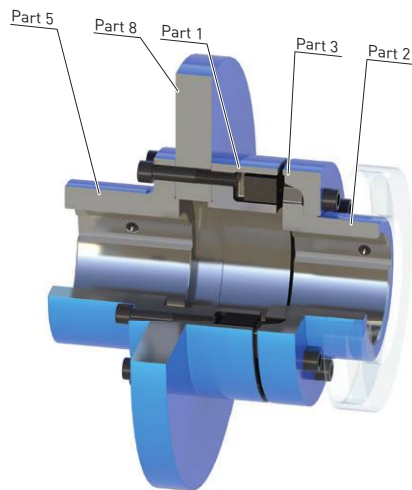

Type DBDR

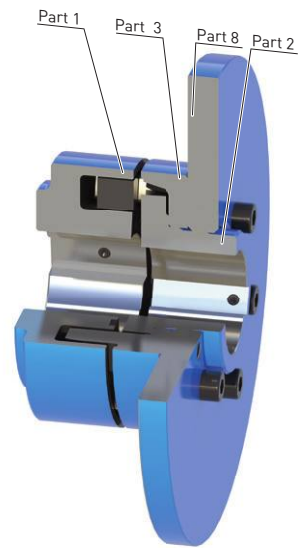

Type ABD

Type N-EUPEX with torque control

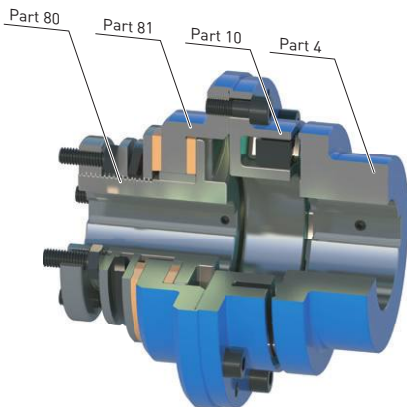

Type ERN

Note

- Further application-specific coupling types are available. Dimension sheets for and information on these are available on request.

GENERAL

Technical specifications, N-EUPEX series

Power ratings of the N-EUPEX series (single-joint coupling)										
Size	Rated torque for flexible type			Maximum torque		Torsional stiffness at 50 % capacity utilization for flexible type			Permitted shaft misalignment at speed ¹⁾ n = 1500 rpm	
	65 ShoreA	80 ShoreA	HP ²⁾	65 ShoreA	80 ShoreA / HP	65 ShoreA	80 ShoreA	HP	Radial	Angle
	T_{KN}	T_{KN}	T_{KN}	T_{Kmax}	T_{Kmax}	$C_{Tdyn 50\%}$	$C_{Tdyn 50\%}$	$C_{Tdyn 50\%}$	ΔK_r	ΔK_w
	Nm	Nm	Nm	Nm	Nm	kNm/rad	kNm/rad	kNm/rad	mm	°
58	12	28	34	36	85	0.22	0.75	1,51	0.2	0.15
68	23	48	58	69	145	0.42	1.26	2,79	0.2	0.15
80	40	85	120	120	300	1.13	3.21	14,2	0.2	0.12
95	69	140	200	207	500	1.77	5.32	23,1	0.2	0.12
110	110	225	325	330	812	2.70	8.15	36,1	0.2	0.10
125	165	345	490	495	1225	4.0	12.3	53,6	0.25	0.10
140	250	500	700	750	1750	6.0	18	77,8	0.25	0.10
160	385	840	1200	1150	3000	12.2	39.4	162	0.3	0.10
180	600	1250	1750	1800	4375	20.6	63.6	270	0.3	0.10
200	935	1950	2650	2800	6625	34.2	106.8	426	0.3	0.09
225	1380	2300	3400	4150	8500	52	131	619	0.35	0.09
250	1930	3900	5500	5800	13750	73	221	927	0.35	0.08
280	2700	5500	7400	8100	18500	103	313	1261	0.4	0.08
315	3850	7100	9350	11550	23375	186	472	1130	0.4	0.08
350	5335	10800	13000	16000	32500	255	708	1450	0.5	0.08
400	7150	14000	18000	21450	45000	343	997	2250	0.5	0.08
440	9350	19000	25000	28050	62500	427	1280	3200	0.6	0.08
480	11550	25100	33000	34650	82500	550	1781	4100	0.6	0.07
520	14630	32400	42000	43890	105000	650	2124	4800	0.65	0.07
560	20130	39000	50600	60390	126500	1095	3119	7600	0.65	0.07
610	26400	49000	63800	79200	159500	1422	3873	9400	0.75	0.07
660	33990	63000	79000	101970	197500	1799	4834	11300	0.8	0.07
710	42900	71000	93500	128700	233750	2339	5608	13400	0.9	0.07

For coupling fatigue torque:

$$T_{KW} = 0,15 \cdot T_{KN}, \text{ where } T_N > T_W \text{ must be adhered to.}$$

N-EUPEX shaft distance S and radial misalignment ΔK_r

N-EUPEX (single-joint coupling)

Radial misalignment ΔK_r and angular misalignment ΔK_w as well as changes in gap dimension are equalized in a elastomer joint. Values for ΔS can be found in the respective type selection tables.

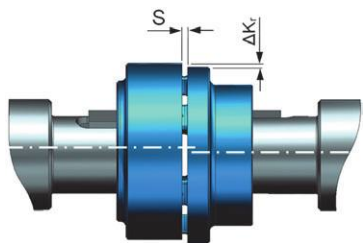

N-EUPEX DK/DKS (two-joint coupling)

Radial misalignment ΔK_r and angular misalignment ΔK_w as well as changes in gap dimension are equalized in two elastomer joints. Values for ΔS can be found in the corresponding type selection tables.

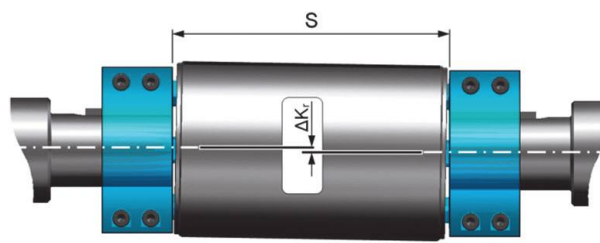

¹⁾ The maximum speed for the respective type must be noted. For additional information on the allowable shaft misalignment, please refer to the operating instructions.

²⁾ For sizes 80 to 280, in case of higher temperatures the temperature factor FT according to the table on page E/19 in the Introduction has to be considered.

Performance data for type N-EUPEX DK (two-joint coupling)											
Size	Rated torque	Maximum torque	Torsional stiffness at 50 % capacity utilization for flexible type	Permitted shaft misalignment ¹⁾ at n = 1500 rpm					Type DKS	Angle ²⁾	
	HP T_{KN} Nm	HP T_{Kmax} Nm		HP $C_{Tdyn 50\%}$ kNm/rad	Radial Type DK	S=100 mm $\Delta K_{r 100}$ mm	S=140 mm $\Delta K_{r 140}$ mm	S=180 mm $\Delta K_{r 180}$ mm			S=200 mm $\Delta K_{r 200}$ mm
68	48	120	1.18	1.2	-	-	-	-	-	-	0.15
80	85	212	5.6	1.2	1.7	-	-	-	0.5	0.12	
95	140	350	9	1.1	1.6	-	-	-	0.5	0.12	
110	225	562	14	1.1	1.5	2.1	-	-	0.6	0.10	
125	345	862	21	1.0	1.5	2.0	2.3	-	0.6	0.10	
140	500	1250	31	1.0	1.4	1.8	2.1	2.7	0.7	0.10	
160	840	2100	63	-	1.3	1.8	2.1	2.7	0.7	0.10	
180	1250	3125	107	-	1.3	1.8	2.0	2.6	0.7	0.10	
200	1950	4875	170	-	1.2	1.7	2.0	2.6	0.8	0.09	
225	2300	5750	240	-	-	1.7	1.9	2.6	0.9	0.09	
250	3900	9750	370	-	-	-	-	-	1.1	0.08	
280	5500	13750	525	-	-	-	-	-	1.1	0.08	

For coupling fatigue torque:
 $T_{KW} = 0,15 \cdot T_{KN}$, where $T_N > T_W$ must be adhered to.

Torsional stiffness and damping (single-joint or two-joint coupling)

The values stated in the above table apply to a capacity utilization of 50 %, an excitation amplitude of 10 % T_{KN} with frequency 10 Hz and an ambient temperature of 20 °C. The dynamic torsional stiffness is load-dependent and increases in proportion to capacity utilization. The following table shows the correction factors for different rated loads.

$$C_{Tdyn} = C_{Tdyn 50\%} \cdot FKC$$

	Load T_N / T_{KN}						
	20 %	40 %	50 %	60 %	70 %	80 %	100 %
Correction factor FKC							
65/80 ShoreA							
HP (size 58-68, 315-710)	0,50	0,82	1,00	1,20	1,40	1,63	2,10
HP (size 80 - 280)	0,55	0,85	1,00	1,14	1,29	1,42	1,69

The damping coefficient is $\Psi = 1.4$ for the 65/80 ShoreA packages and $\Psi = 1.2$ for the HP package

Furthermore, torsional stiffness and damping depend on the ambient temperature, on the frequency and on the amplitude of the torsional vibration excitation. More precise torsional stiffness and damping parameters on request.

Due to the manufacturing process and ageing of the elastomers, the tolerance for the dynamic stiffness is $\pm 20\%$.

Permitted shaft misalignment (single-joint or two-joint coupling)

The permitted shaft misalignment depends on the operating speed. As the speed increases, lower shaft misalignment values are permitted. The correction factors for different speeds are specified in the following table. The maximum speed for the respective coupling size must be noted!

$$\Delta K_{perm} = \Delta K_{1500} \cdot FKV$$

	Speed in rpm			
	500	1000	1500	3000
Correction factor FKV	1.7	1.2	1.0	0.7

For fitting, the maximum gap dimension of $S_{max.} = S + \Delta S$ and the minimum gap dimension of $S_{min.} = S - \Delta S$ are permitted.

Shaft misalignments ΔK_r and ΔK_w may occur simultaneously.

¹⁾ The maximum speed for the respective type must be noted. For additional information on the allowable shaft misalignment, please refer to the operating instructions.
²⁾ The angular misalignment ΔK_w refers to the maximum additional tilting of the shaft axes.

GENERAL

Assignment of N-EUPEX sizes to IEC standard motors (selected operating factor = 1.25) ¹⁾

Three-phase motor Size	Output at ≈ 3000 rpm		Output at ≈ 1500 rpm		Output at ≈ 1000 rpm		Output at ≈ 750 rpm		DE (ASI) shaft end D x E acc. to IEC	
	P_M kW	N-EUPEX size	P_M kW	N-EUPEX size	P_M kW	N-EUPEX size	P_M kW	N-EUPEX size	D mm	E mm
56	0.09	58	0.06	58					9	20
56	0.12	58	0.09	58					9	20
63	0.18	58	0.12	58					11	23
63	0.25	58	0.18	58					11	23
71	0.37	58	0.25	58					14	30
71	0.55	58	0.37	58					14	30
80	0.75	58	0.55	58	0.37	58			19	40
80	1.1	58	0.75	58	0.55	58			19	40
90 S	1.5	58	1.1	58	0.75	58			24	50
90 L	2.2	58	1.5	58	1.1	58			24	50
100 L	3	68	2.2	68	1.5	68	0.75	68	28	60
100 L			3	68			1.1	68	28	60
112 M	4	68	4	68	2.2	68	1.5	68	28	60
132 S	5.5	80	5.5	80	3	80	2.2	80	38	80
132 S	7.5	80							38	80
132 M			7.5	80	4	80	3	80	38	80
132 M					5.5	80			38	80
160 M	11	80	11	95	7.5	95	4	80	42	110
160 M	15	80					5.5	95	42	110
160 L	18.5	80	15	95	11	95	7.5	95	42	110
180 M	22	95	18.5	110					48	110
180 L			22	110	15	110	11	110	48	110
200 L	30	110	30	125	18.5	110	15	125	55	110
200 L	37	110			22	125			55	110
225 S									55	110
225 S			37	125			18.5	125	60	140
225 M	45	110							55	110
225 M			45	140	30	140	22	140	60	140
250 M	55	125							60	140
250 M			55	140	37	140	30	140	65	140
280 S	75	140							65	140
280 S			75	180	45	180	37	180	75	140
280 M	90	140							65	140
280 M			90	180	55	180	45	180	75	140
315 S	110	140							65	140
315 S			110	180	75	180	55	180	80	170
315 M	132	160							65	140
315 M			132	180	90	180	75	180	80	170
315 L	160	160							65	140
315 L	200	160							65	140
315 L			160	200	110	200	90	200	80	170
315 L			200	200	132	200	110	200	80	170
315 L					160	200	132	225	85	170
315	250	180							65	140
315	315	200							65	140
315			250	225	200	250			85	170
355	355	200							75	140
355	400	200							75	140
355	500	225							75	140

¹⁾ Outputs P_M of IEC motors and assigned N-EUPEX couplings (80 ShoreA)

TYPE A

for easy elastomer flexible replacement

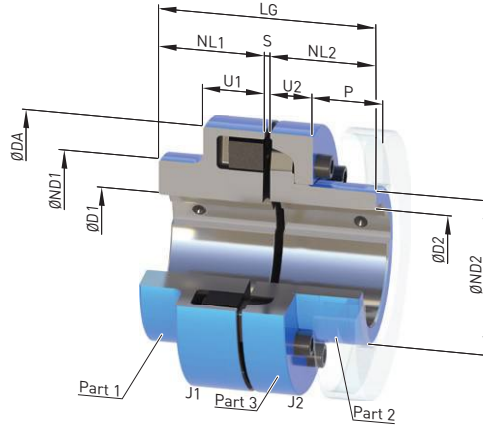

Size	Rated torque flexible type 80 ShoreA T_{KN} Nm	Speed n_{Kmax} rpm	Dimensions in mm Bore with keyway to DIN 6885-1														Mass moment of inertia J_1/J_2 kgm ²	Article no. ¹⁾	Weight m kg
			D1		D2		DA	ND1 ²⁾	ND2	NL1/ NL2	S	ΔS +/-	U1	U2	P	LG			
110	225	6300	-	55	-	45	110	86	60.5	40	3	1.0	34	20	33	83	0.002	2LC0170-4AB	2.7
125	345	6100	-	60	-	55	125	100	73.5	50	3	1.0	36	23	38	103	0.004	2LC0170-5AB	4.2
140	500	5800	-	65	-	60	140	100	80.5	55	3	1.0	34	28	43	113	0.007	2LC0170-6AB	5.6
160	840	5100	-	70	-	70	160	108	93.5	60	4	2.0	39	28	47	124	0.013	2LC0170-7AB	7.8
180	1250	4500	-	80	-	80	180	125	106	70	4	2.0	42	30	50	144	0.023	2LC0170-8AB	11
200	1950	4000	-	85	-	90	200	140	119	80	4	2.0	47	32	53	164	0.04	2LC0171-0AB	16
225	2300	3600	-	90	-	100	225	150	135	90	4	2.0	52	38	61	184	0.07	2LC0171-1AB	23
250	3900	3300	46	100	-	115	250	165	153	100	5.5	2.5	60	42	69	205.5	0.13	2LC0171-2AB	32
280	5500	3000	49	110	54	125	280	180	168	110	5.5	2.5	65	42	73	225.5	0.20	2LC0171-3AB	42
315	7100	2600	49	120	45	145	315	200	196	125	5.5	2.5	70	47	78	255.5	0.37	2LC0171-4AB	61
350	10800	2400	61	140	60	165	350	230	226	140	5.5	2.5	74	51	83	285.5	0.64	2LC0171-5AB	85
400	14000	2000	66	150	65	180	400	250	246	160	5.5	2.5	78	56	88	325.5	1.1	2LC0171-6AB	119
440	19000	1900	80	160	80	190	440	265	261	180	7.5	2.5	86	64	99	367.5	1.7	2LC0171-7AB	156
480	25100	1800	90	180	90	215	480	300	296	190	7.5	2.5	90	65	104	387.5	2.7	2LC0171-8AB	199
520	32400	1500	100	190	100	225	520	315	310	210	7.5	2.5	102	68	115	427.5	3.8	2LC0172-0AB	251
560	39000	1500	120	200	120	230	560	320	316	220	9	3.0	115	80	125	449	5.3	2LC0172-1AB	303
610	49000	1300	130	220	130	250	610	352	348	240	9	3.0	121	88	135	489	8.2	2LC0172-2AB	393
660	63000	1200	140	240	140	275	660	384	380	260	9	3.0	132	96	145	529	12.3	2LC0172-3AB	501
710	71000	1100	140	260	140	300	710	416	412	290	9	3.0	138	102	155	589	17.4	2LC0172-4AB	623

Configurable variants ¹⁾

- ØD1 Without finished bore
With finished bore
- ØD2 Without finished bore
With finished bore

Notes

- Weights and mass moments of inertia apply to maximum bores.

Ordering example

- N-EUPEX A coupling, size 200
- Part 1: Bore D1 65H7 mm, keyway to DIN 6885-1 and set screw
- Part 2: Bore D2 50H7 mm, keyway to DIN 6885-1 and set screw

Article no.: 2LC0171-0AB99-0AA0 L1F+M1C

¹⁾ To identify complete item numbers specifying the available finish boring options and – if necessary – further order options, please use our configurators on flender.com.

²⁾ The hub diameter HD1 can be smaller for small bores.

➤ For online configuration on flender.com, click on the item no.

TYPE B

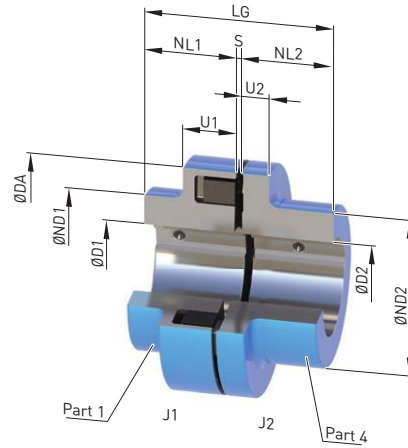

7

Size	Rated torque flexible type 80 ShoreA T_{KN} Nm	Speed n_{Kmax} rpm	Dimensions in mm Bore with keyway to DIN 6885-1											Mass moment of inertia J_1/J_2 kgm ²	Article no. ¹⁾	Weight m kg			
			D1		D2		Part 40 ²⁾			DA	ND1	ND2	NL1/NL2				S	ΔS	U1
			min.	max.	min.	max.	max.							±					
58	28	9000	-	22	-	25	32	58	58	40	20	3	1.0	20	8	43	0.0001	2LC0170-0AA	0.4
68	48	8400	-	28	-	30	40	68	68	50	20	3	1.0	20	8	43	0.0002	2LC0170-1AA	0.6
80	85	7200	-	38	-	42	48	80	80	68	30	3	1.0	30	10	63	0.0006	2LC0170-2AA	1.3
95	140	6600	-	48	-	48	60	95	76	76	35	3	1.0	30	12	73	0.0012	2LC0170-3AA	1.8
110	225	6300	-	55	-	55	70	110	86	86	40	3	1.0	34	14	83	0.0024	2LC0170-4AA	2.8
125	345	6100	-	60	-	60	82	125	100	100	50	3	1.0	36	18	103	0.005	2LC0170-5AA	4.7
140	500	5800	-	65	-	65	90	140	100	100	55	3	1.0	34	20	113	0.007	2LC0170-6AA	5.7
160	840	5100	-	70	-	70	105	160	108	108	60	4	2.0	39	20	124	0.01	2LC0170-7AA	7.8
180	1250	4500	-	80	-	80	120	180	125	125	70	4	2.0	42	20	144	0.02	2LC0170-8AA	12
200	1950	4000	-	85	-	85	130	200	140	140	80	4	2.0	47	24	164	0.04	2LC0171-0AA	17
225	2300	3600	-	90	-	90	150	225	150	150	90	4	2.0	52	18	184	0.06	2LC0171-1AA	23
250	3900	3300	46	100	46	100	170	250	165	165	100	5.5	2.5	60	18	205.5	0.11	2LC0171-2AA	30
280	5500	3000	49	110	54	110	190	280	180	180	110	5.5	2.5	65	20	225.5	0.18	2LC0171-3AA	41

Configurable variants ¹⁾

- ØD1 Without finished bore
With finished bore
- ØD2 Without finished bore
With finished bore

Notes

- Weights and mass moments of inertia apply to maximum bores.

Ordering example

- N-EUPEX B coupling, size 95
- Part 1: Bore D1 42H7 mm, keyway to DIN 6885-1 and set screw
- Part 2: Bore D2 32H7 mm, keyway to DIN 6885-1 and set screw

Article no.: 2LC0170-3AA99-0AA0 L0X+M0T

¹⁾ To identify complete item numbers specifying the available finish boring options and – if necessary – further order options, please use our configurators on flender.com.

²⁾ Version with part 40 (jumbo hub) available on request.

➤ For online configuration on flender.com, click on the item no.

TYPE B

with clamping elements

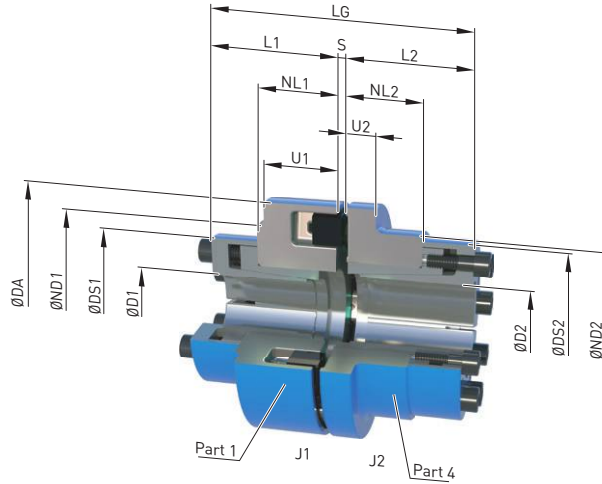

Size	Rated torque ²⁾ flexible type 80 ShoreA T_{KN} Nm	Speed n_{Kmax} rpm	Dimensions in mm														Mass moment of inertia		Article no. ¹⁾	Weight m kg
			D1 max.	D2 max.	DA	ND1	ND2	NL1	NL2	S	ΔS +/-	DS1	DS2	L1	L2	LG	J_1 kgm ²	J_2 kgm ²		
80	85	7200	25	30	80	80	68	30	26	3	1.0	56	62	50	46	99	0.0007	0.0011	2LC0170-2BF	2.0
95	140	6600	30	38	95	95	76	30	31	3	1.0	62	72	50	51	104	0.0013	0.0012	2LC0170-3BF	2.7
110	225	6300	38	40	110	88	86	35	31	3	1.0	72	75	55	51	109	0.0027	0.0035	2LC0170-4BF	3.8
125	345	6100	40	48	125	125	100	35	46	3	1.0	75	87	55	71	129	0.0046	0.0062	2LC0170-5BF	5.9
140	500	5800	40	48	140	101	100	39	46	3	1.0	75	87	59	71	133	0.0067	0.0089	2LC0170-6BF	7.1
160	840	5100	55	55	160	108	108	52	52	4	2.0	98	98	77	77	158	0.013	0.014	2LC0170-7BF	10
180	1250	4500	65	65	180	125	125	52	52	4	2.0	111	111	77	77	158	0.021	0.024	2LC0170-8BF	13
200	1950	4000	70	75	200	140	140	62	62	4	2.0	119	126	93	93	190	0.039	0.047	2LC0171-0BF	19
225	2300	3600	75	75	225	150	150	63	63	4	2.0	126	126	94	94	192	0.064	0.063	2LC0171-1BF	24
250	3900	3300	85	85	250	165	165	70	70	5.5	2.5	137	137	101	101	207.5	0.11	0.10	2LC0171-2BF	32
280	5500	3000	85	85	280	180	180	77	77	5.5	2.5	137	137	108	108	221.5	0.18	0.16	2LC0171-3BF	43

Configurable variants¹⁾

- ØD1 with clamping element
- ØD2 with clamping element

Notes

- For dimensions U1 and U2, see type B on page 7/12.
- Weights and mass moments of inertia apply to maximum bores.
- Recommended shaft tolerances h8 to m6

Ordering example

- N-EUPEX B coupling with clamping element, size 95
- Part 1: Bore D1 30 mm
recommended shaft tolerances h8 to m6
- Part 4: Bore D2 38 mm
recommended shaft tolerances h8 to m6

Article no.: 2LC0170-3BF99-0AA0 L0S+M0V

¹⁾ To identify complete item numbers specifying the available size of the clamping element and – if necessary – further order options, please use our configurators on flender.com.

²⁾ If clamping elements are used, their maximum permissible torques must be observed. The relevant information can be consulted through our configurators on flender.com.

➤ For online configuration on flender.com, click on the item no.

TYPE DK

for large misalignment with simple installation and removal

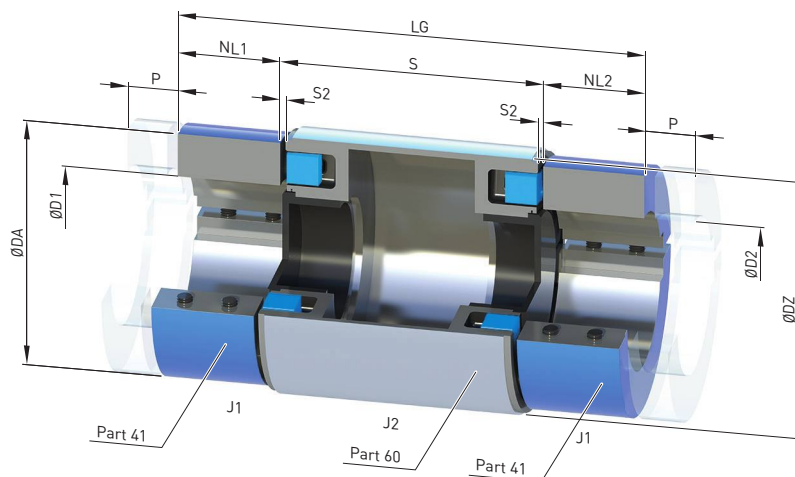

Size	Rated torque flexible type HP T_{KN}	Speed n_{Kmax}	Dimensions in mm											Mass moment of inertia		Article no. ¹⁾	Weight m
			Bore with keyway to DIN 6885-1		DA	DZ	NL1/NL2	Shaft distances S ²⁾		ΔS	S2	P	LG	J_1	J_2		
			D1/D2	min.				max.	Preferred dimension								
68	48	5500	20	40	68	70	30	100		1	2	15	160	0.0004	0.0003	2LC0170-1BA	1.66
80	85	5300	25	48	80	86	34	100	140	1	2	16	168	0.001	0.001	2LC0170-2BA	2.64
95	140	5100	25	60	95	100	40	100	140	1	2	18	180	0.002	0.002	2LC0170-3BA	4.0
110	225	4800	30	70	110	120	45	100	140, 180	1	2	21	190	0.004	0.005	2LC0170-4BA	6.0
125	345	4600	30	82	125	130	50	140	100, 180, 200	1	2.5	24	240	0.008	0.007	2LC0170-5BA	8.2
140	500	4400	40	90	140	150	54	140	100, 180, 200, 250	1	2.5	26	248	0.013	0.014	2LC0170-6BA	11.8
160	840	4000	40	105	160	170	70	140	180, 200, 250	1.5	3	30	280	0.030	0.024	2LC0170-7BA	18.3
180	1250	3700	40	120	180	190	75	180	140, 200, 250	1.5	3	32	330	0.051	0.043	2LC0170-8BA	24.8
200	1950	3400	45	130	200	210	80	180	140, 200, 250	1.5	3.5	35	340	0.085	0.069	2LC0171-0BA	33.7
225	2300	3000	45	150	225	240	90	180	200, 250	1.5	3.5	39	360	0.152	0.123	2LC0171-1BA	46.9

Configurable variants ¹⁾

- ØD1 With finished bore
- ØD2 With finished bore

Notes

- The total length, weight and mass moments of inertia apply to maximal bores and shaft distances according to the preferred dimension.
- Recommended share tolerances j_6 to p_6
- A combination of part 60 with other cam parts as part 41 is not permitted.

Ordering example

- N-EUPEX DK coupling, size 95, S = 100 mm
- Part 41-1: Bore D1 42 mm, with keyway as per DIN 6885-1, recommended shaft tolerances j_6 to p_6
- Part 41-2: Bore D1 32 mm, with keyway as per DIN 6885-1, recommended shaft tolerances j_6 to p_6

Article no.: 2LC0170-3BA99-0AA0 L0X+M0T

¹⁾ To identify complete item numbers specifying the available finish boring options and – if necessary – further order options, please use our configurators on flender.com.

²⁾ Special lengths on request.

➤ For online configuration on flender.com, click on the item no.

TYPE DKS

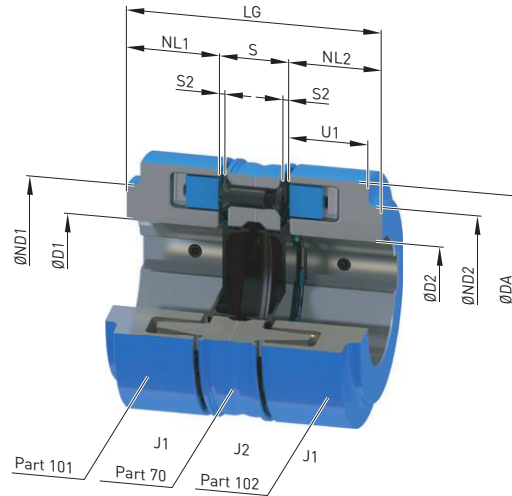

Size	Rated torque flexible type HP T_{KN} Nm	Speed n_{Kmax} rpm	Dimensions in mm										Mass moment of inertia		Article no. ¹⁾	Weight m kg	
			Bore with keyway to DIN 6885-1 D1/D2		DA	ND1/ND2	NL1/NL2	S	ΔS +/-	S2	U1	LG	J_1 kgm ²	J_2 kgm ²			
			min.	max.													
80	85	5300	-	38	80	80	30	26	1.0	2	30	86	0.0006	0.0007	2LC0170-2BD	1.8	
95	140	5100	-	48	95	76	35	26	1.0	2	30	96	0.0012	0.0013	2LC0170-3BD	2.6	
110	225	4800	-	55	110	86	40	28	1.0	2	34	108	0.0024	0.0025	2LC0170-4BD	4.0	
125	345	4600	-	60	125	100	50	29	1.0	2.5	36	129	0.005	0.004	2LC0170-5BD	5.9	
140	500	4400	-	65	140	100	55	35	1.0	2.5	34	145	0.006	0.008	2LC0170-6BD	7.6	
160	840	4000	-	70	160	108	60	36	1.5	3	39	156	0.012	0.014	2LC0170-7BD	11	
180	1250	3700	-	80	180	125	70	36	1.5	3	42	176	0.021	0.023	2LC0170-8BD	15	
200	1950	3400	-	85	200	140	80	41	1.5	3.5	47	201	0.038	0.040	2LC0171-0BD	22	
225	2300	3000	-	90	225	150	90	41	1.5	3.5	52	221	0.065	0.070	2LC0171-1BD	31	
250	3900	2600	46	100	250	165	100	54	2.0	4	60	254	0.11	0.14	2LC0171-2BD	44	
280	5500	2400	49	110	280	180	110	54	2.0	4	65	274	0.19	0.21	2LC0171-3BD	58	

Configurable variants ¹⁾

- ØD1 Without finished bore
With finished bore
- ØD2 Without finished bore
With finished bore

Notes

- The total length, weight and mass moments of inertia apply to maximal bores and shaft distances according to the preferred dimension.

Ordering example

- N-EUPEX DKS coupling, size 95
- Part 1-01: Bore D1 42H7 mm, with keyway as per DIN 6885-1 and set screw
- Part 1-02: Bore D2 32H7 mm, with keyway as per DIN 6885-1 and set screw

Article no.: 2LC0170-3BD99-0AA0 L0X+M0T

¹⁾ To identify complete item numbers specifying the available finish boring options and – if necessary – further order options, please use our configurators on flender.com.

➤ For online configuration on flender.com, click on the item no.

TYPE H

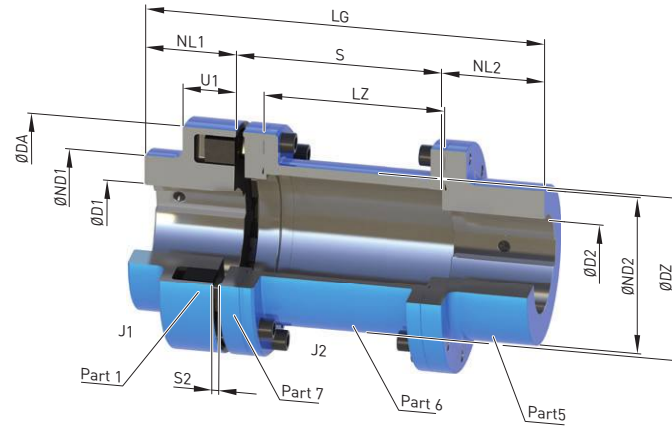

Size	Rated torque flexible type 80 ShoreA T_{KN} Nm	Speed n_{Kmax} rpm	Dimensions in mm														Mass moment of inertia		Article no. ¹⁾	Weight m kg		
			Bore with keyway to DIN 6885-1				DA	ND1 ²⁾	ND2	NL1	NL2	S	S2	LZ	DZ	LG	J_1 kgm ²	J_2 kgm ²				
D1 min.	D1 max.	D2 min.	D2 max.																			
80	85	7200	-	38	-	38 ³⁾	80	80	55	30	45	100	5	87	51	175	0.0006	0.001	2LC0170-2AG	2.4		
												140		127		215		0.001		2LC0170-2AG	2.5	
95	140	6600	-	48	-	48 ³⁾	95	76	70	35	45	100	5	87	63	180	0.0009	0.003	2LC0170-3AG	3.3		
												140		127		220		0.003		2LC0170-3AG	3.6	
110	225	6300	-	55	-	55 ³⁾	110	86	80	40	50	100	85	73	190	0.003	0.005	2LC0170-4AG	4.8			
											50		140		5		125		230	0.006	2LC0170-4AG	5.0
125	345	6100	-	60	-	60 ³⁾	125	100	90	50	50	5	125	85	240	0.005	0.01	2LC0170-5AG	6.9			
											60		180		5		165		280	0.006	2LC0170-4AG	5.6
											50		100		85		200		0.01	2LC0170-5AG	7.4	
											50		140		125		240		0.01	2LC0170-5AG	7.4	
											60		180		5		165		85	290	0.011	2LC0170-5AG
70	200	185	320	0.012	2LC0170-5AG	8.1																
80	250	235	380	0.012	2LC0170-5AG	8.6																
140	500	5800	-	65	-	65 ³⁾	140	100	100	55	65	100	82	91	220	0.007	0.018	2LC0170-6AG	9.6			
											65		140		122		260		0.019	2LC0170-6AG	10.1	
											65		180		5		162		300	0.02	2LC0170-6AG	10.6
											65		200		182		320		0.021	2LC0170-6AG	10.9	
80	250	232	385	0.022	2LC0170-6AG	11.5																

Configurable variants ¹⁾

- ØD1 Without finished bore
With finished bore
- ØD2 Without finished bore
With finished bore

¹⁾ To identify complete item numbers specifying the available finish boring options and – if necessary – further order options, please use our configurators on flender.com.

²⁾ The hub diameter HD1 can be smaller for small bores.

³⁾ For bore diameters greater than the following values, the feather key must be at least 3 mm behind the shaft end. Size 80 D2 > 32 mm; size 95 D2 > 42 mm; size 110 D2 > 50 mm; size 125 D2 > 59 mm; size 140 D2 > 64 mm.

↗ For online configuration on flender.com, click on the item no.

Size	Rated torque flexible type 80 ShoreA T_{KN} Nm	Speed n_{Kmax} rpm	Dimensions in mm													Mass moment of inertia		Article no. ¹⁾	Weight m kg	
			Bore with keyway to DIN 6885-1				DA	ND1 ²⁾	ND2	NL1	NL2	S	S2	LZ	DZ	LG	J_1 kgm ²			J_2 kgm ²
D1	D2		D3		D4													D5		
min.	max.	min.	max.	min.	max.	min.	max.	min.	max.	min.	max.	min.	max.	min.	max.	min.	max.			
160	840	5100	-	70	-	70	160	108	108	60	70	100	81.5	230	0.013	0.03	2LC0170-7AG	12.5		
																	0.032	2LC0170-7AG	13	
																	0.034	2LC0170-7AG	14	
																	0.035	2LC0170-7AG	14	
180	1250	4500	-	80	-	80	180	125	125	70	80	140	121.5	270	0.023	0.053	2LC0170-8AG	18		
																	0.057	2LC0170-8AG	19	
																	0.059	2LC0170-8AG	20	
																	0.064	2LC0170-8AG	21	
200	1950	4000	-	85	-	90	200	140	140	80	90	180	158.5	350	0.04	0.094	2LC0171-0AG	25		
																	0.099	2LC0171-0AG	26	
																	0.104	2LC0171-0AG	27	
																	0.109	2LC0171-0AG	28	
225	2300	3600	-	90	-	100	225	150	150	90	100	180	158.5	370	0.07	0.157	2LC0171-1AG	33		
																	0.16	2LC0171-1AG	34	
																	0.17	2LC0171-1AG	35	
																	0.18	2LC0171-1AG	37	
250	3900	3300	46	100	46	110	250	165	165	100	110	200	172.5	185	0.12	0.27	2LC0171-2AG	48		
																	0.28	2LC0171-2AG	50	
																	0.3	2LC0171-2AG	52	
280	5500	3000	49	110	51	130	280	180	180	110	120	250	8	222.5	215	480	0.20	0.51	2LC0171-3AG	67
315	7100	2600	49	120	51	140	315	200	200	125	140	250	8	222.5	246	515	0.35	0.85	2LC0171-4AG	96
350	10800	2400	61	140	51	160	350	230	230	140	150	250	8	220.5	272	540	0.61	1.4	2LC0171-5AG	120
400	14000	2000	66	150	51	180	400	250	250	160	180	250	8	185.5	311	590	1.1	2.8	2LC0171-6AG	190
440	19000	1900	80	160	51	190	440	265	265	180	180	250	10	182	354	610	1.7	4.0	2LC0171-7AG	219

Configurable variants¹⁾

- ØD1 Without finished bore
With finished bore
- ØD2 Without finished bore
With finished bore

Notes

- For dimension U1, see type A on page 7/11.
- During assembly, the gap dimension S2 must not exceed the permissible tolerance of +1 mm.
- Weights and mass moments of inertia apply to maximum bores.

Ordering example

- N-EUPEX H coupling, size 160, S = 200 mm
- Part 1: Bore D1 60H7 mm, keyway to DIN 6885-1 and set screw
- Part 2: Bore D2 55H7 mm, keyway to DIN 6885-1 and set screw

Article no.: 2LC0170-7AG99-0AD0 L1E+M1D

¹⁾ To identify complete item numbers specifying the available finish boring options and – if necessary – further order options, please use our configurators on flender.com.

²⁾ The hub diameter HD1 can be smaller for small bores

↗ For online configuration on flender.com, click on the item no.

TYPE D

for easy elastomer flexible replacement

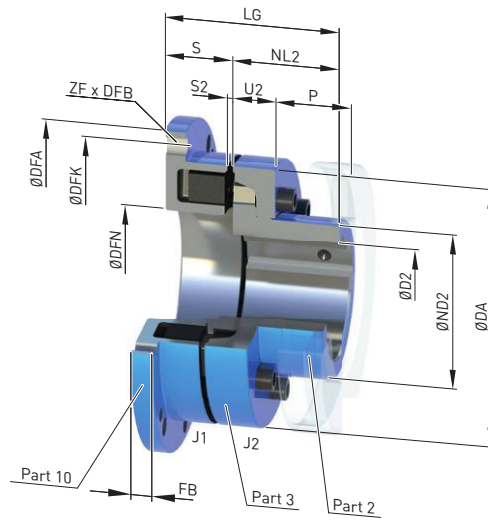

7

Size	Rated torque flexible type 80 ShoreA T_{KN} Nm	Speed n_{Kmax} rpm	Dimensions in mm										Flange connection dimensions						Mass moment of inertia		Article no. ¹⁾	Weight m kg
			Bore with keyway to DIN 6885-1		DA	ND2	NL2	S	ΔS +/-	S2	LG	DFA h8	DFN H7	DFK	FB	ZF	DFB	J_1 kgm ²	J_2 kgm ²			
D2 min.	max.	D2 min.	max.																			
110	225	6300	-	45	110	60.5	40	30	1.0	3	70	144	62	128	10	6	$\frac{9}{M8}$	0.0033	0.002	2LC0170-4AD1 2LC0170-4AD2	2.6	
125	345	6000	-	55	125	73.5	50	34	1.0	3	84	158	75	142	10	6	$\frac{9}{M8}$	0.005	0.004	2LC0170-5AD1 2LC0170-5AD2	3.5	
140	500	5300	-	60	140	80.5	55	37	1.0	3	92	180	82	160	13	6	$\frac{11}{M10}$	0.010	0.007	2LC0170-6AD1 2LC0170-6AD2	5.4	
160	840	4800	-	70	160	93.5	60	43	2.0	4	103	200	95	180	13	7	$\frac{11}{M10}$	0.016	0.013	2LC0170-7AD1 2LC0170-7AD2	7.1	
180	1250	4300	-	80	180	106	70	46	2.0	4	116	220	110	200	13	8	$\frac{11}{M10}$	0.025	0.023	2LC0170-8AD1 2LC0170-8AD2	9.5	
200	1950	3900	-	90	200	119	80	51	2.0	4	131	248	120	224	16	8	$\frac{14}{M12}$	0.049	0.04	2LC0171-0AD1 2LC0171-0AD2	14	
225	2300	3600	-	100	225	135	90	56	2.0	4	146	274	135	250	16	8	$\frac{14}{M12}$	0.076	0.07	2LC0171-1AD1 2LC0171-1AD2	19	
250	3900	3000	-	115	250	153	100	65.5	2.5	5.5	165.5	314	150	282	20	8	$\frac{18}{M16}$	0.15	0.13	2LC0171-2AD1 2LC0171-2AD2	28	
280	5500	3000	54	125	280	168	110	70.5	2.5	5.5	180.5	344	170	312	20	8	$\frac{18}{M16}$	0.23	0.2	2LC0171-3AD1 2LC0171-3AD2	35	

Configurable variants ¹⁾

- ØD2 Without finished bore
With finished bore

¹⁾ To identify complete item numbers specifying the available finish boring options and – if necessary – further order options, please use our configurators on flender.com.

↗ For online configuration on flender.com, click on the item no.

Size	Rated torque flexible type 80 ShoreA T_{KN} Nm	Speed n_{Kmax} rpm	Dimensions in mm										Flange connection dimensions						Mass moment of inertia		Article no. ¹⁾	Weight m kg
			Bore with keyway to DIN 6885-1		DA	ND2	NL2	S	ΔS +/-	S2	LG	DFA h8	DFN H7	DFK	FB	ZF	DFB	J_1 kgm ²	J_2 kgm ²			
D2 min.	max.																					
315	7100	2500	45	145	315	196	125	75.5	2.5	5.5	200.5	380	200	348	22	9	18 M16	0.4	0.37	2LC0171-4AD1 2LC0171-4AD2	48	
350	10800	2200	60	165	350	226	140	79.5	2.5	5.5	219.5	430	225	390	25	9	22 M20	0.7	0.64	2LC0171-5AD1 2LC0171-5AD2	68	
400	14000	2000	65	180	400	246	160	83.5	2.5	5.5	243.5	480	265	440	25	10	22 M20	1.1	1.1	2LC0171-6AD1 2LC0171-6AD2	89	
440	19000	1800	80	190	440	261	180	93.5	2.5	7.5	273.5	520	295	480	25	10	22 M20	1.6	1.7	2LC0171-7AD1 2LC0171-7AD2	117	
480	25100	1800	90	215	480	296	190	97.5	2.5	7.5	287.5	575	325	528	30	10	26 M24	2.6	2.7	2LC0171-8AD1 2LC0171-8AD2	149	
520	32400	1500	100	225	520	310	210	109.5	2.5	7.5	319.5	615	355	568	30	10	26 M24	3.6	3.8	2LC0172-0AD1 2LC0172-0AD2	182	

Configurable variants ¹⁾

- ØD2 Without finished bore
With finished bore

Notes

- For dimensions U2 and P, see type A on page 7/11.
- Weights and mass moments of inertia apply to maximum bores.

Ordering example

- N-EUPEX D coupling, size 125
- Part 10: with through bores
- Part 2: Bore D2 38H7 mm, with keyway to DIN 6885-1 and set screw

Article no.: 2LC0170-5AD19-0AA0 M0V

¹⁾ To identify complete item numbers specifying the available finish boring options and – if necessary – further order options, please use our configurators on flender.com.

➤ For online configuration on flender.com, click on the item no.

TYPE E

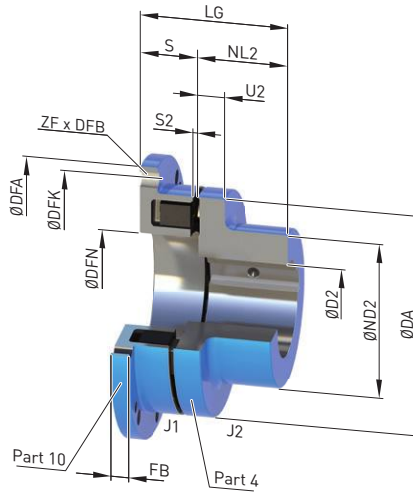

Size	Rated torque flexible type 80 ShoreA T_{KN} Nm	Speed n_{Kmax} rpm	Dimensions in mm											Mass moment of inertia			Article no. ¹⁾	Weight m kg			
			Bore with keyway to DIN 6885-1		Flange connection dimensions									J_1 kgm ²	J_2 kgm ²						
			D2 min.	max.	DA	ND2	NL2	S	ΔS +/-	S2	LG	DFA h8	DFN H7	DFK	FB	ZF	DFB				
68	48	8400	-	30	68	50	20	23	1.0	3	43	90	34	80	7	6	$\frac{5.5}{M5}$	0.0004	0.0002	2LC0170-1AC1 2LC0170-1AC2	0.7
80	85	7200	-	42	80	68	30	24	1.0	3	54	106	42	94	8	6	$\frac{6.6}{M6}$	0.0008	0.0006	2LC0170-2AC1 2LC0170-2AC2	1.2
95	140	6600	-	48	95	76	35	27	1.0	3	62	120	52	108	8	6	$\frac{6.6}{M6}$	0.0013	0.0012	2LC0170-3AC1 2LC0170-3AC2	1.7
110	225	6300	-	55	110	86	40	30	1.0	3	70	144	62	128	10	6	$\frac{9}{M8}$	0.0033	0.0024	2LC0170-4AC1 2LC0170-4AC2	2.6
125	345	6000	-	60	125	100	50	34	1.0	3	84	158	75	142	10	6	$\frac{9}{M8}$	0.005	0.005	2LC0170-5AC1 2LC0170-5AC2	4.0
140	500	5300	-	65	140	100	55	37	1.0	3	92	180	82	160	13	6	$\frac{11}{M10}$	0.010	0.007	2LC0170-6AC1 2LC0170-6AC2	5.5
160	840	4800	-	70	160	108	60	43	2.0	4	103	200	95	180	13	7	$\frac{11}{M10}$	0.016	0.01	2LC0170-7AC1 2LC0170-7AC2	7.1

Configurable variants ¹⁾

- ØD2 Without finished bore
With finished bore

¹⁾ To identify complete item numbers specifying the available finish boring options and – if necessary – further order options, please use our configurators on flender.com.

↗ For online configuration on flender.com, click on the item no.

Size	Rated torque flexible type 80 ShoreA T_{KN} Nm	Speed n_{Kmax} rpm	Dimensions in mm											Flange connection dimensions						Mass moment of inertia		Article no. ¹⁾	Weight m kg
			Bore with keyway to DIN 6885-1		DA	ND2	NL2	S	ΔS +/-	S2	LG	DFA h8	DFN H7	DFK	FB	ZF	DFB	J_1 kgm ²	J_2 kgm ²				
			D2 min.	max.																			
180	1250	4300	-	80	180	125	70	46	2.0	4	116	220	110	200	13	8	$\frac{11}{M10}$	0.025	0.02	2LC0170-8AC1 2LC0170-8AC2	10		
200	1950	3900	-	85	200	140	80	51	2.0	4	131	248	120	224	16	8	$\frac{14}{M12}$	0.049	0.04	2LC0171-0AC1 2LC0171-0AC2	15		
225	2300	3600	-	90	225	150	90	56	2.0	4	146	274	135	250	16	8	$\frac{14}{M12}$	0.076	0.06	2LC0171-1AC1 2LC0171-1AC2	19		
250	3900	3000	46	100	250	165	100	65.5	2.5	5.5	165.5	314	150	282	20	8	$\frac{18}{M16}$	0.15	0.11	2LC0171-2AC1 2LC0171-2AC2	26		
280	5500	3000	54	110	280	180	110	70.5	2.5	5.5	180.5	344	170	312	20	8	$\frac{18}{M16}$	0.23	0.18	2LC0171-3AC1 2LC0171-3AC2	34		

Configurable variants ¹⁾

- ØD2 Without finished bore
With finished bore

Notes

- For dimension U2, see type B on page 7/12.
- Weights and mass moments of inertia apply to maximum bores.

Ordering example

- N-EUPEX E coupling, size 125
- Part 10: with through bores
- Part 4: Bore D2 38H7 mm, with keyway to DIN 6885-1 and set screw

Article no.: **2LC0170-5AC19-0AA0 M0V**

¹⁾ To identify complete item numbers specifying the available finish boring options and – if necessary – further order options, please use our configurators on flender.com.

➤ For online configuration on flender.com, click on the item no.

TYPE P

with brake drum

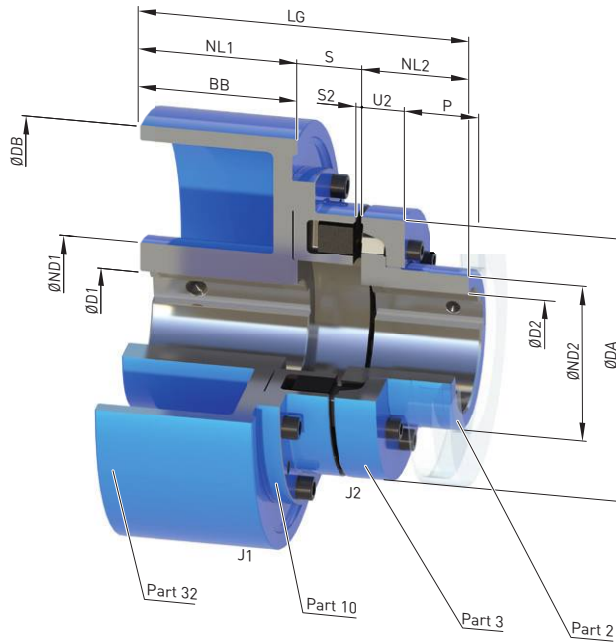

Size	Rated torque flexible type 80 ShoreA T_{KN} Nm	Speed n_{Kmax} rpm	Dimensions in mm											Mass moment of inertia		Article no. ¹⁾	Weight m kg					
			Bore with keyway to DIN 6885-1		DA	ND1	ND2	NL1/BB	NL2	S	ΔS +/-	S2	DB	U2	LG			J_1 kgm ²	J_2 kgm ²			
D1 min.	D1 max.	D2 min.	D2 max.																			
125	345	4800	-	55	-	55	125	84	73.5	75	50	31	1.0	3	200	23	156	0.043	0.004	2LC0170-5AF	11	
140	500	3800	-	60	-	60	140	128	80.5	95	55	34	1.0	3	250	28	184	0.13	0.007	2LC0170-6AF	21	
160	840	3800	-	70	-	70	160	128	93.5	95	60	40	2.0	4	250	28	195	0.14	0.013	2LC0170-7AF	21	
180	1250	3800	-	80	-	80	180	128	106	95	70	41	2.0	4	250	30	206	0.16	0.023	2LC0170-8AF	27	
200	1950	3000	-	80	-	90	200	128	118	118	80	48	2.0	4	400	32	278	1.1	0.04	2LC0171-0AF	39	
200	1950	1900	-	110 ²⁾	-	90	200	175	119	190	80	48	2.0	4	400	32	278	1.1	0.04	2LC0171-0AF	59	
225	2300	3000	-	80	-	100	225	128	118	118	80	51	2.0	4	400	38	293	1.1	0.07	2LC0171-1AF	46	
225	2300	2400	-	90	-	100	225	160	135	150	90	53	2.0	4	400	38	293	1.1	0.07	2LC0171-1AF	64	
		1900	38	110				175	190	190	80	53	2.0	4	500	333	3.1		2LC0171-1AF	103		

Configurable variants ¹⁾

- ØD1 Without finished bore
With finished bore
- ØD2 Without finished bore
With finished bore

¹⁾ To identify complete item numbers specifying the available finish boring options and – if necessary – further order options, please use our configurators on flender.com.

²⁾ For bore diameters greater than the following values, the feather key must be at least 3 mm behind the shaft end. Size 200 D1 > 100 mm.

↗ For online configuration on flender.com, click on the item no.

Size	Rated torque flexible type 80 ShoreA T_{KN} Nm	Speed n_{Kmax} rpm	Dimensions in mm													Mass moment of inertia		Article no. ¹⁾	Weight m kg		
			Bore with keyway to DIN 6885-1		D1	D2	DA	ND1	ND2	NL1/BB	NL2	S	ΔS +/-	S2	DB	U2	LG			J_1 kgm ²	J_2 kgm ²
min.	max.	min.	max.																		
250	3900	2400	-	100	-	115	250	160	153	150	100	62.5	2.5	5.5	400	42	312.5	1.16	0.13	2LC0171-2AF	74
		1900	38	110	-	115	250	175	190	190	100	62.5	2.5	5.5	500	42	352.5	2.9		2LC0171-2AF	111
		2400	-	100	-	115	250	160	150	150	100	65.5	2.5	5.5	400	42	325.5	1.24		2LC0171-3AF	82
280	5500	1900	48	110	54	125	280	175	168	190	110	67.5	2.5	5.5	500	42	367.5	3.1	0.2	2LC0171-3AF	115
		1500	48	110	-	125	280	175	236	236	110	67.5	2.5	5.5	630	42	413.5	8.0		2LC0171-3AF	168
		2400	-	100	-	125	280	160	150	150	110	72.5	2.5	5.5	400	42	347.5	1.4		2LC0171-4AF	92
315	7100	1900	48	110	45	145	315	175	196	190	125	72.5	2.5	5.5	500	47	387.5	3.3	0.37	2LC0171-4AF	131
		1500	48	110	-	145	315	175	236	236	125	72.5	2.5	5.5	630	47	433.5	8.2		2LC0171-4AF	180
		1300	55	120	-	145	315	192	265	265	125	72.5	2.5	5.5	710	47	462.5	14.2		2LC0171-4AF	233
350	10800	1500	48	110	60	165	350	175	226	236	140	76.5	2.5	5.5	630	51	452.5	8.5	0.64	2LC0171-5AF	197
		1300	55	120	-	165	350	192	265	265	140	76.5	2.5	5.5	710	51	481.5	14.6		2LC0171-5AF	251

Configurable variants ¹⁾

- ØD1 Without finished bore
With finished bore
- ØD2 Without finished bore
With finished bore

Notes

- For dimension P, see type A on page 7/11.
- Weights and mass moments of inertia apply to maximum bores.

Ordering example

- N-EUPEX P coupling, size 200, brake drum 315 x 118 mm
- Part 32: Bore D1 55H7 mm, keyway to DIN 6885-1 P9 and set screw
- Part 4: Bore D2 60H7 mm, keyway to DIN 6885-1 and set screw
- Coupling micro-balanced G 6.3 at 1500 rpm in accordance with half parallel key standard

Article no.: **2LC0171-0AF99-0DA0-Z L1D+M1E+W02+Y95**
Plain text to Y95: G=6.3;n=1500rpm

¹⁾ To identify complete item numbers specifying the available finish boring options and – if necessary – further order options, please use our configurators on flender.com.

➤ For online configuration on flender.com, click on the item no.

TYPE O

with brake drum

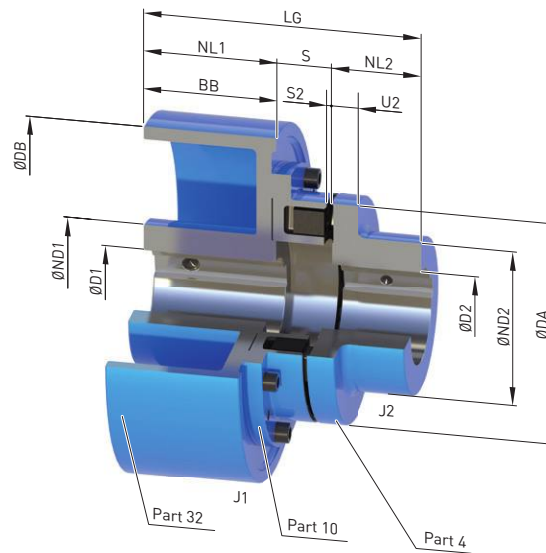

7

Size	Rated torque flexible type 80 ShoreA T_{KN} Nm	Speed n_{Kmax} rpm	Dimensions in mm														Mass moment of inertia		Article no. ¹⁾	Weight m kg	
			Bore with keyway to DIN 6885-1				DA	ND1	ND2	NL1/BB	NL2	S	ΔS +/-	S2	DB	U2	LG	J_1 kgm ²			J_2 kgm ²
			D1 min.	D1 max.	D2 min.	D2 max.															
125	345	4800	-	55	-	60	125	84	100	75	50	31	1.0	3	200	18	156	0.043	0.005	2LC0170-5AE	11
140	500	3800	-	60	-	65	140	128	100	95	55	34	1.0	3	250	20	184	0.13	0.007	2LC0170-6AE	22
160	840	3800	-	70	-	70	160	128	108	95	60	40	2.0	4	250	20	195	0.14	0.01	2LC0170-7AE	24
180	1250	3800	-	80	-	80	180	128	125	95	70	41	2.0	4	250	20	206	0.16	0.02	2LC0170-8AE	28
		3000	-	80	118	43				315		231			0.35		2LC0170-8AE			35	
200	1950	3000	-	80	-	85	200	160	140	118	80	48	2.0	4	315	24	246	0.37	0.04	2LC0171-0AE	40
		2400	-	90	128	48				400		278			1.10		2LC0171-0AE			60	
		1900	-	110 ²⁾	175	48				500		318			2.80		2LC0171-0AE			98	

Configurable variants¹⁾

- ØD1 Without finished bore
With finished bore
- ØD2 Without finished bore
With finished bore

¹⁾ To identify complete item numbers specifying the available finish boring options and – if necessary – further order options, please use our configurators on flender.com.

²⁾ For bore diameters greater than the following values, the feather key must be at least 3 mm behind the shaft end. Size 200 D1 > 100 mm.

↗ For online configuration on flender.com, click on the item no.

Size	Rated torque flexible type 80 ShoreA T_{KN} Nm	Speed n_{Kmax} rpm	Dimensions in mm													Mass moment of inertia		Article no. ¹⁾	Weight m kg		
			Bore with keyway to DIN 6885-1		D1 min.	D1 max.	D2 min.	D2 max.	DA	ND1	ND2	NL1/BB	NL2	S	ΔS +/-	S2	DB			U2	LG
225	2300	3000	-	80																	
		2400	-	90	-	90	225	160	150	150	90	53	2.0	4	400	18	293	1.10	0.06	2LC0171-1AE	63
		1900	38	110				175	190			53			500		333	3.10		2LC0171-1AE	102
250	3900	2400	-	100				160	165	150	100	62.5	2.5	5.5	400	18	312.5	1.16	0.11	2LC0171-2AE	73
		1900	38	110	46	100	250	175	190	190	100	62.5			500		352.5	2.90		2LC0171-2AE	108
280	5500	2400	-	100				160	150	150		65.5			400		325.5	1.24		2LC0171-3AE	82
		1900	48	110	54	110	280	175	180	190	110	67.5	2.5	5.5	500	20	367.5	3.10	0.18	2LC0171-3AE	115
		1500	48	110				175	236			67.5			630		413.5	8.0		2LC0171-3AE	168

Configurable variants ¹⁾

- ØD1 Without finished bore
With finished bore
- ØD2 Without finished bore
With finished bore

Notes

- Weights and mass moments of inertia apply to maximum bores.

Ordering example

- N-EUPEX O coupling, size 200, brake drum 315 x 118 mm
- Part 32: Bore D1 55H7 mm, keyway to DIN 6885-1 P9 and set screw
- Part 4: Bore D2 60H7 mm, keyway to DIN 6885-1 and set screw
- Coupling micro-balanced G 6.3 at 1500 rpm in accordance with half parallel key standard

Article no.: **2LC0171-0AE99-0DA0-Z L1D+M1E+W02+Y95**
Plain text to Y95: G=6.3;n=1500rpm

¹⁾ To identify complete item numbers specifying the available finish boring options and – if necessary – further order options, please use our configurators on flender.com.

➤ For online configuration on flender.com, click on the item no.

TYPE DBDR

with brake disk

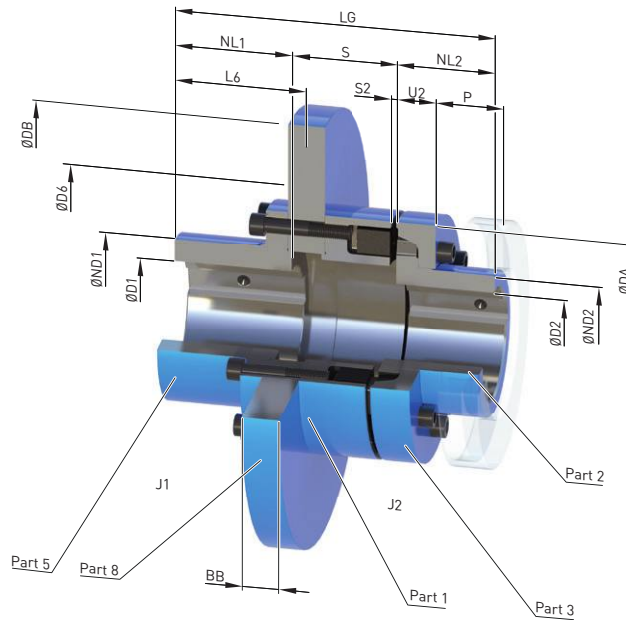

Size	Rated torque flexible type 80 ShoreA T_{KN} Nm	Dimensions in mm																Mass moment of inertia		Article no. ¹⁾	Weight m kg
		Bore with keyway to DIN 6885-1			DA	ND1	ND2	NL1	NL2	S	ΔS +/-	S2	DB ²⁾ min.	D6 min.	BB ²⁾	L6	LG	J_1 min. kgm ²	J_2 kgm ²		
		D1 max.	D2 min.	max.																	
140	500	60	-	60	140	85	80.5	72	55	54.35	1.0	3	315	150	12.7	74	181.35	0.11	0.008	2LC0170-6AV	14.7
								188	73	57.5					30	200	316	0.24			16.2
								90	60	62.5					12.7	91	208.35	0.12			26.9
160	840	75	-	70	160	105	93.5	90	60	58.35	2.0	4	315	170	15	94	212.5	0.14	0.013	2LC0170-7AV	18.5
								188	78	60.35					30	200	326	0.26			20
								90	70	64.5					12.7	91	220.35	0.35			31
180	1250	90	-	80	180	125	106	90	70	60.35	2.0	4	315	190	15	94	224.5	0.37	0.024	2LC0170-8AV	25
								188	80	62.5					30	200	338	0.57			26
								95	80	67.35					12.7	97	242.35	0.32			42
200	1950	95	-	90	200	135	119	95	80	70.5	2.0	4	355	210	15	99	245.5	0.36	0.04	2LC0171-0AV	32
								188	86	67.35					30	200	354	0.67			35
								95	80	70.5					12.7	97	242.35	0.32			54

Configurable variants ¹⁾

- ØD1 With finished bore
- ØD2 Without finished bore
With finished bore

¹⁾ To identify complete item numbers specifying the available finish boring options and – if necessary – further order options, please use our configurators on flender.com.

²⁾ For the available DB · BB brake disk dimensions, please refer to the product configurator on flender.com.

➤ For online configuration on flender.com, click on the item no.

Size	Rated torque flexible type 80 ShoreA T_{KN} Nm	Dimensions in mm															Mass moment of inertia		Article no. ¹⁾	Weight m kg	
		Bore with keyway to DIN 6885-1			DA	ND1	ND2	NL1	NL2	S	ΔS +/-	S2	DB ²⁾ min.	D6 min.	BB ²⁾	L6	LG	J_1 min. kgm ²			J_2 kgm ²
225	2300	115	-	100	225	160	135	100	90	72.35	2.0	4	400	235	12.7	103	262.35	0.52	0.08	2LC0171-1AV	43
					188	90	74.5	15	104	264.5					0.59	46					
					30	200	368	1.1	71												
250	3900	120	-	115	250	170	153	105	100	83.35	+2/-3	6	450	260	12.7	107	288.35	1.6	0.12	2LC0171-2AV	56
					188	102	86.5	15	109	291.5					1.7	59					
					30	200	390	2.5	88												
280	5500	140	54	125	280	200	168	120	110	87.35	+2/-3	6	500	350	12.7	122	317.35	1.3	0.19	2LC0171-3AV	73
					188	106	90.5	15	124	320.5					1.5	77					
					30	200	404	2.7	112												
315	7100	140	45	145	315	200	196	130	125	87.35	+2/-3	6	500	350	12.7	130	342.35	2.1	0.33	2LC0171-4AV	95
					188	108	92.5	15	134	347.5					2.3	100					
					30	200	421	4.2	140												
350	10800	165	60	165	350	230	226	135	140	97.35	+2/-3	6	500	360	12.7	136	372.35	3.3	0.57	2LC0171-5AV	129
					188	117	101.5	15	139	376.5					3.8	134					
					30	200	445	6.7	184												

Configurable variants ¹⁾

- ØD1 With finished bore
- ØD2 Without finished bore
With finished bore

Notes

- For dimensions U2 and P, see type A on page 7/11.
- Weights and mass moments of inertia apply to maximum bores.
- Maximum speed $n_{max} = 1528/DB$ (n_{max} in rpm, DB in m)
Observe maximum speed of type A.
- Other brake disk diameters DB and brake disk widths BB on request.

Ordering example

- N-EUPEX DBDR coupling, size 200,
brake disk 450 x 30 mm
- Part 5: Bore D1 55H7 mm, keyway to DIN 6885-1 P9
and set screw
- Part 2: Bore D2 60H7 mm, keyway to DIN 6885-1
and set screw
- Coupling micro-balanced G 6.3 at 1500 rpm in accordance with
half parallel key standard

Article no.: 2LC0171-0AV99-0GA0-Z L1D+M1E+W02+Y95
Plain text to Y95: G=6.3;n=1500rpm

¹⁾ To identify complete item numbers specifying the available finish boring options and – if necessary – further order options, please use our configurators on fender.com.

²⁾ For the available DB · BB brake disk dimensions, please refer to the product configurator on fender.com.

↗ For online configuration on fender.com, click on the item no.

TYPE ABD

with brake disk

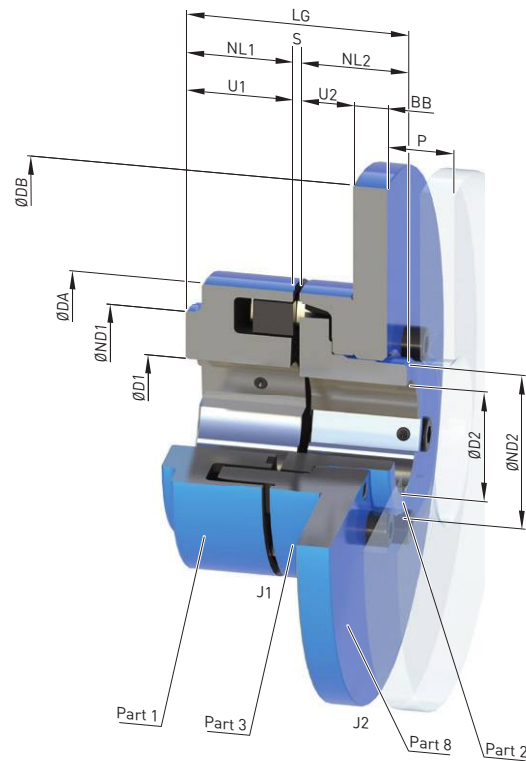

Size	Rated torque flexible type 80 ShoreA T_{KN} Nm	Speed n_{Kmax} rpm	Dimensions in mm Bore with keyway to DIN 6885-1														Mass moment of inertia		Article no. ¹⁾	Weight m kg		
			D1		D2		DA	ND1 ²⁾	ND2	NL1/NL2	S	ΔS +/-	U1	U2	P	DB ³⁾	BB ³⁾	LG			J_1 kgm ²	J_2 kgm ²
			min.	max.	min.	max.								min.								
140	500	5500	-	65	-	60	140	100	80.5	55	3	1.0	34	28	43	315	12.7	113	0.007	0.10	2LC0170-6BB	12.8
160	840	5100	-	70	-	70	160	108	93.5	60	4	2.0	39	28	47	315	12.7	124	0.013	0.11	2LC0170-7BB	14.8
180	1250	4500	-	80	-	80	180	125	106	70	4	2.0	42	30	50	355	12.7	144	0.023	0.18	2LC0170-8BB	20
200	1950	4000	-	85	-	90	200	140	119	80	4	2.0	47	32	53	400	12.7	164	0.04	0.29	2LC0171-0BB	27
225	2300	3600	-	90	-	100	225	150	135	90	4	2.0	52	38	61	450	30	184	0.07	1.0	2LC0171-1BB	57
250	3900	3300	46	100	-	115	250	165	153	100	5.5	2.5	60	42	69	500	30	205.5	0.13	1.6	2LC0171-2BB	73
280	5500	3000	49	110	54	125	280	180	168	110	5.5	2.5	65	42	73	560	30	225.5	0.20	2.5	2LC0171-3BB	94
315	7100	2600	49	120	45	145	315	200	196	125	5.5	2.5	70	47	78	630	30	255.5	0.37	4.0	2LC0171-4BB	126
350	10800	2400	61	140	60	165	350	230	226	140	5.5	2.5	74	51	83	710	30	285.5	0.64	6.5	2LC0171-5BB	167

Configurable variants ¹⁾

- ØD1 Without finished bore
With finished bore
- ØD2 Without finished bore
With finished bore

Notes

- Weights and mass moments of inertia apply to maximum bores.

Ordering example

- N-EUPEX ABD coupling, size 200, brake disk 400 x 12.7 mm
- Part 1: Bore D1 65H7 mm, keyway to DIN 6885-1 and set screw
- Part 2: Bore D2 50H7 mm, keyway to DIN 6885-1 P9 and set screw
- Coupling micro-balanced G 6.3 at 1500 rpm in accordance with half parallel key standard

Article no.: **2LC0171-0BB99-2FA0-Z L1F+M1C+W02+Y95**
Plain text to Y95: G=6.3;n=1500rpm

¹⁾ To identify complete item numbers specifying the available finish boring options and – if necessary – further order options, please use our configurators on flender.com.

²⁾ The hub diameter HD1 can be smaller for small bores.

³⁾ For the available DB · BB brake disk dimensions, please refer to the product configurator on flender.com.

↗ For online configuration on flender.com, click on the item no.

TYPE ERN

with slip unit

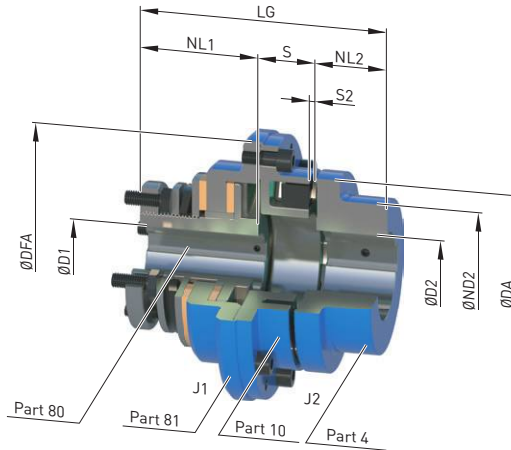

Size	Rated torque flexible type 80 ShoreA T_{KN} Nm	Maximum slip torque ²⁾ Spring set		Speed n_{Kmax} rpm	Dimensions in mm											Mass moment of inertia		Article no. ¹⁾	Weight m kg
		T_{R1} Nm	T_{R2} Nm		D1 max.	D2 max.	DA	ND2	NL1	NL2	S	ΔS +/-	S2	DFA	LG	J_1 kgm ²	J_2 kgm ²		
80	85	130	240	3800	30	42	80	68	55	30	25	1.0	3	109	110	0.0039	0.0006	2LC0170-2BE	3.3
95	140	190	340	3600	35	48	95	76	66	35	28	1.0	3	123	129	0.007	0.0012	2LC0170-3BE	4.8
110	225	190	340	3600	35	55	110	86	66	40	31	1.0	3	147	137	0.010	0.0024	2LC0170-4BE	5.8
125	345	350	650	3000	45	60	125	100	77	50	35	1.0	3	161	162	0.017	0.005	2LC0170-5BE	8.9
140	500	650	1200	2500	60	65	140	100	86	55	38	1.0	3	183	179	0.035	0.008	2LC0170-5BE	13
160	840	650	1200	2500	60	70	160	108	86	60	44	2.0	4	204	190	0.050	0.013	2LC0170-7BE	15
180	1250	1000	1800	2100	65	80	180	125	93	70	47	2.0	4	224	210	0.084	0.025	2LC0170-8BE	22
200	1950	2200	4000	1800	80	85	200	140	105	80	52	2.0	4	252	237	0.16	0.044	2LC0171-0BE	32
225	2300	2200	4000	1800	80	90	225	150	105	90	57	2.0	4	278	252	0.22	0.064	2LC0171-1BE	37
250	3900	3800	6800	1500	90	100	250	165	120	100	66.5	2.5	5.5	319	286.5	0.51	0.10	2LC0171-2BE	60
280	5500	5500	10000	1500	120	110	280	180	120	110	71.5	2.5	5.5	349	301.5	0.77	0.17	2LC0171-3BE	74

Configurable variants¹⁾

- ØD1 With finished bore
- ØD2 Without finished bore
With finished bore

Notes

- Weights and mass moments of inertia apply to maximum bores.

Ordering example

- N-EUPEX ERN coupling, size 200
Slip torque $T_R = 4000$ Nm
- Part 1: Bore D1 65H7 mm, keyway to DIN 6885-1 and set screw
- Part 2: Bore D2 50H7 mm, keyway to DIN 6885-1 and set screw

Article no.: 2LC0171-0BE99-2AA0 L1F+M1C

¹⁾ To identify complete item numbers specifying the available finish boring options and – if necessary – further order options, please use our configurators on flender.com.

²⁾ Adjustable slip torque according to operating instructions.

↗ For online configuration on flender.com, click on the item no.

GENERAL

Technical specifications, N-EUPEX DS series

Power ratings of the N-EUPEX DS series						
Size	Rated torque	Maximum torque	Torsional stiffness at 50 % capacity utilization ¹⁾	Assembly	Permitted shaft misalignment at speed ³⁾ $n = 1500$ rpm	
	T_{KN} Nm	T_{Kmax} Nm	C_{Tdyn} kNm/rad	Gap dimension ²⁾ ΔS mm	Radial ΔK_r mm	Angle ΔK_w °
66	19	38	0.73	1.0	0.2	0.15
76	34	68	1.36	1.0	0.2	0.15
88	60	120	2.62	1.0	0.2	0.12
103	100	200	4.00	1.0	0.2	0.12
118	160	320	6.30	1.0	0.2	0.10
135	240	480	10.5	1.0	0.25	0.10
152	360	720	13.6	1.0	0.25	0.10
172	560	1120	27.2	2.0	0.3	0.10
194	880	1760	47.0	2.0	0.3	0.10
218	1340	2680	70.0	2.0	0.3	0.09
245	2000	4000	106	2.0	0.35	0.09
272	2800	5600	149	2.5	0.35	0.08
305	3900	7800	214	2.5	0.4	0.08
340	5500	11000	350	2.5	0.4	0.08
380	7700	15400	480	2.5	0.5	0.08
430	10300	20600	730	2.5	0.5	0.08
472	13500	27000	990	2.5	0.6	0.08
514	16600	33200	1270	2.5	0.6	0.07
556	21200	42400	1540	2.5	0.65	0.07

For coupling fatigue torque:

$T_{KW} = 0,15 \cdot T_{KN}$, where $T_N > T_W$ must be adhered to.

Note

For fitting, the maximum gap dimension of $S_{max.} = S + \Delta S$ and the minimum gap dimension of $S_{min.} = S - \Delta S$ are permitted.

¹⁾ The correction factors for torsion spring stiffness and permitted shaft misalignment correspond to the specifications for the puncture-proof types [page 7/9](#)

²⁾ Does not apply to type HDS.

³⁾ The maximum speed for the respective type must be noted. For additional information on the allowable shaft misalignment, please refer to the operating instructions.

TYPE ADS

for easy elastomer flexible replacement

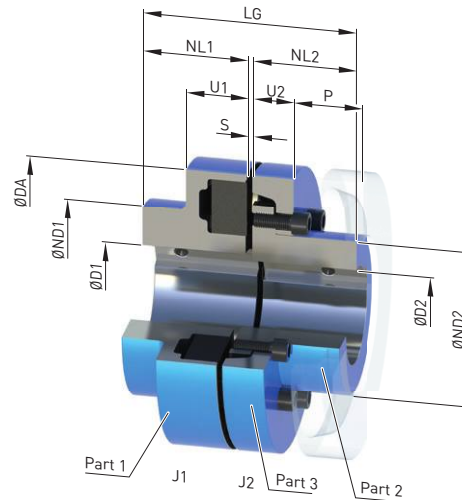

Size	Rated torque T_{KN} Nm	Speed n_{Kmax} rpm	Dimensions in mm													Mass moment of inertia J_1/J_2 kgm ²	Article no. ¹⁾	Weight m kg
			Bore with keyway to DIN 6885-1				DA	ND1	ND2	NL1/ NL2	S	U1	U2	P	LG			
			D1	D2	min.	max.												
118	160	5300	-	50	-	45	118	86	60.5	40	3	34	20	33	83	0.003	2LC0110-4AB	2.8
135	240	5100	-	60	-	55	135	100	73.5	50	3	36	23	38	103	0.005	2LC0110-5AB	4.3
152	360	4900	-	65	-	60	152	108	80.5	55	3	36	28	43	113	0.008	2LC0110-6AB	5.9
172	560	4250	-	70	-	70	172	118	93.5	60	4	41	28	47	124	0.014	2LC0110-7AB	8.2
194	880	3800	-	80	-	80	194	135	106	70	4	44	30	50	144	0.025	2LC0110-8AB	12
218	1340	3400	-	85	-	90	218	150	119	80	4	47	32	53	164	0.05	2LC0111-0AB	17
245	2000	3000	-	90	-	100	245	150	135	90	4	52	38	61	184	0.08	2LC0111-1AB	23
272	2800	2750	46	100	-	115	272	165	153	100	5.5	60	42	69	205.5	0.14	2LC0111-2AB	32
305	3900	2450	49	110	54	125	305	180	168	110	5.5	65	42	73	225.5	0.22	2LC0111-3AB	43
340	5500	2150	49	120	45	145	340	200	196	125	5.5	70	47	78	255.5	0.39	2LC0111-4AB	61
380	7700	2000	61	140	60	165	380	230	226	140	5.5	74	51	83	285.5	0.69	2LC0111-5AB	86
430	10300	1700	66	150	65	180	430	250	246	160	5.5	78	56	88	325.5	1.2	2LC0111-6AB	120
472	13500	1550	80	160	80	190	472	265	261	180	7.5	86	64	99	367.5	1.9	2LC0111-7AB	161
514	16600	1400	90	180	90	215	514	300	296	190	7.5	90	65	104	387.5	2.9	2LC0111-8AB	206
556	21200	1300	100	190	100	225	556	315	310	210	7.5	102	68	115	427.5	4.1	2LC0112-0AB	256

Configurable variants ¹⁾

- ØD1 Without finished bore
With finished bore
- ØD2 Without finished bore
With finished bore

Notes

- Weights and mass moments of inertia apply to maximum bores.

Ordering example

- N-EUPEX ADS coupling, size 135
- Part 1: Bore D1 42H7 mm, keyway to DIN 6885-1 and set screw
- Part 2: Bore D2 32H7 mm, keyway to DIN 6885-1 and set screw

Article no.: 2LC0110-5AB99-0AA0 L0X+M0T

¹⁾ To identify complete item numbers specifying the available finish boring options and – if necessary – further order options, please use our configurators on flender.com.

↗ For online configuration on flender.com, click on the item no.

TYPE BDS

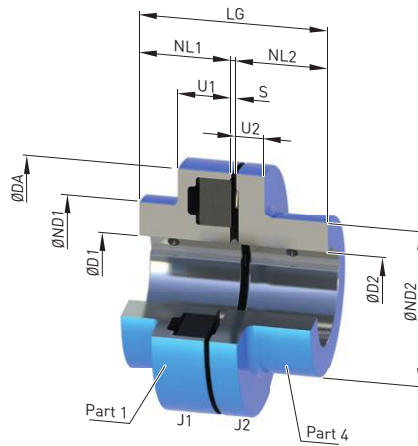

Size	Rated torque T_{KN} Nm	Speed n_{Kmax} rpm	Dimensions in mm											Mass moment of inertia J_1/J_2 kgm ²	Article no. ¹⁾	Weight m kg	
			Bore with keyway to DIN 6885-1				DA	ND1	ND2	NL1/ NL2	S	U1	U2				LG
			D1 min.	D1 max.	D2 min.	D2 max.											
66	19	7500	-	20	-	25	66	66	40	20	3	20	8	43	0.0001	2LC0110-0AA	0.46
76	34	7000	-	28	-	30	76	76	50	20	3	20	8	43	0.0002	2LC0110-1AA	0.64
88	60	6000	-	35	-	42	88	88	68	30	3	30	10	63	0.0008	2LC0110-2AA	1.4
103	100	5500	-	45	-	48	103	76	76	35	3	30	12	73	0.0015	2LC0110-3AA	2.1
118	160	5300	-	50	-	55	118	86	86	40	3	34	14	83	0.003	2LC0110-4AA	3.0
135	240	5100	-	60	-	60	135	100	100	50	3	36	18	103	0.006	2LC0110-5AA	5.1
152	360	4900	-	65	-	65	152	108	100	55	3	36	20	113	0.009	2LC0110-6AA	6.4
172	560	4250	-	70	-	70	172	118	108	60	4	41	20	124	0.016	2LC0110-7AA	8.7
194	880	3800	-	80	-	80	194	135	125	70	4	44	20	144	0.028	2LC0110-8AA	13
218	1340	3400	-	85	-	85	218	150	140	80	4	47	24	164	0.052	2LC0111-0AA	19
245	2000	3000	-	90	-	90	245	150	150	90	4	52	18	184	0.078	2LC0111-1AA	24
272	2800	2750	46	100	46	100	272	165	165	100	5.5	60	18	205.5	0.13	2LC0111-2AA	32
305	3900	2450	49	110	54	110	305	180	180	110	5.5	65	20	225.5	0.21	2LC0111-3AA	43

Configurable variants ¹⁾

- ØD1 Without finished bore
With finished bore
- ØD2 Without finished bore
With finished bore

Ordering example

- N-EUPEX BDS coupling, size 103
- Part 1: Bore D1 42H7 mm, keyway to DIN 6885-1 and set screw
- Part 4: Bore D2 32H7 mm, keyway to DIN 6885-1 and set screw

Article no.: 2LC0110-3AA99-0AA0 L0X+M0T

Notes

- Weights and mass moments of inertia apply to maximum bores.

¹⁾ To identify complete item numbers specifying the available finish boring options and – if necessary – further order options, please use our configurators on flender.com.

➤ For online configuration on flender.com, click on the item no.

TYPE HDS

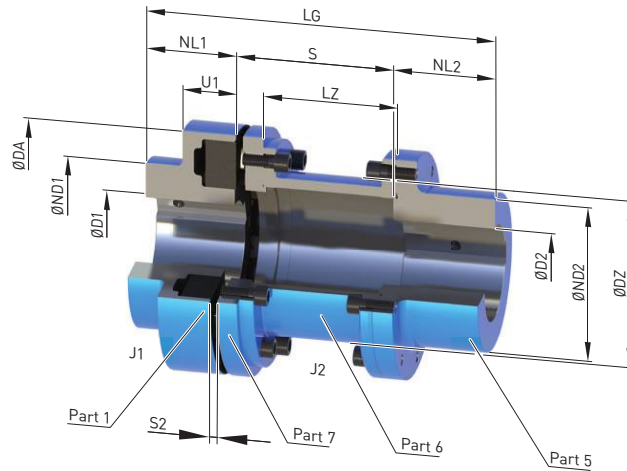

Size	Rated torque T_{KN} Nm	Speed n_{Kmax} rpm	Dimensions in mm													Mass moment of inertia		Article no. ¹⁾	Weight m kg			
			Bore with keyway to DIN 6885-1			DA	ND1	ND2	NL1	NL2	S	S2	LZ	DZ	LG	J_1 kgm ²	J_2 kgm ²					
D1 min.	D1 max.	D2 min.	D2 max.																			
88	60	6000	-	35	-	38 ²⁾	88	88	55	30	45	100	5	87	175	0.0007	0.0014	2LC0110-2AC	2.6			
												140		127	215			0.0015	2LC0110-2AC	2.7		
103	100	5500	-	45	-	48 ²⁾	103	76	70	35	45	100	5	87	180	0.001	0.0029	2LC0110-3AC	3.8			
												140		127	220			0.0032	2LC0110-3AC	4.1		
118	160	5300	-	50	-	55 ²⁾	118	86	80	40	50	100	5	85	190	0.003	0.0059	2LC0110-4AC	4.9			
												50	140	5	125			73	230	0.0063	2LC0110-4AC	5.3
												60	180	5	165			280	0.0066	2LC0110-4AC	5.7	
												50	100	5	85			200	0.01	2LC0110-5AC	7.3	
135	240	5100	-	60	-	60 ²⁾	135	100	90	50	50	140	5	125	240	0.006	0.01	2LC0110-5AC	7.8			
												60	180	5	165			85	290	0.012	2LC0110-5AC	8.2
												70	200	5	185			320	0.012	2LC0110-5AC	8.5	
												80	250	5	235			380	0.013	2LC0110-5AC	9.0	
												65	100	5	82			220	0.02	2LC0110-6AC	10.8	
152	360	4900	-	65	-	65 ²⁾	152	108	100	55	65	140	5	122	260	0.011	0.02	2LC0110-6AC	11.3			
												65	180	5	162			91	300	0.022	2LC0110-6AC	11.8
												65	200	5	182			320	0.023	2LC0110-6AC	12.1	
												65	250	5	232			385	0.024	2LC0110-6AC	12.6	
												80	250	5	232			385	0.024	2LC0110-6AC	12.6	

Configurable variants ¹⁾

- ØD1 Without finished bore
With finished bore
- ØD2 Without finished bore
With finished bore

¹⁾ To identify complete item numbers specifying the available finish boring options and – if necessary – further order options, please use our configurators on flender.com.

²⁾ For bore diameters greater than the following values, the feather key must be at least 3 mm behind the shaft end. Size 88 D2 > 32 mm; size 103 D2 > 42 mm; size 118 D2 > 50 mm; size 135 D2 > 59 mm; size 152 D2 > 64 mm.

↗ For online configuration on flender.com, click on the item no.

Size	Rated torque T_{KN} Nm	Speed n_{Kmax} rpm	Dimensions in mm														Mass moment of inertia		Article no. ¹⁾	Weight m kg
			Bore with keyway to DIN 6885-1				DA	ND1	ND2	NL1	NL2	S	S2	LZ	DZ	LG	J_1 kgm ²	J_2 kgm ²		
			D1 min.	D1 max.	D2 min.	D2 max.														
172	560	4250	-	70	-	70	172	118	108	60	70	100	81.5	230	0.019	0.03	2LC0110-7AC	13.8		
											70	140	121.5	270		0.034	2LC0110-7AC	14.5		
											70	180	161.5	111		0.036	2LC0110-7AC	15.4		
											70	200	181.5	330		0.037	2LC0110-7AC	15.7		
											80	250	231.5	390		0.039	2LC0110-7AC	16.7		
194	880	3800	-	80	-	80	194	135	125	70	80	140	121.5	290	0.037	0.057	2LC0110-8AC	20		
											180	161.5	131	330		0.061	2LC0110-8AC	21		
											200	181.5	350	0.063		2LC0110-8AC	22			
											250	231.5	400	0.068		2LC0110-8AC	23			
											140	118.5	310	0.10		2LC0111-0AC	30			
218	1340	3400	-	85	-	90	218	150	140	80	90	180	158.5	144	350	0.062	0.11	2LC0111-0AC	31	
											200	178.5	370	0.11	2LC0111-0AC		32			
											250	228.5	420	0.12	2LC0111-0AC		33			
											140	118.5	330	0.16	2LC0111-1AC		34			
											180	158.5	370	0.17	2LC0111-1AC		35			
245	2000	3000	-	90	-	100	245	150	150	90	100	200	178.5	169	390	0.09	0.18	2LC0111-1AC	36	
											250	228.5	440	0.19	2LC0111-1AC		38			
											180	152.5	390	0.3	2LC0111-2AC		51			
											200	172.5	185	410	0.16		0.31	2LC0111-2AC	52	
											250	222.5	460	0.33	2LC0111-2AC		55			
305	3900	2450	49	110	51	130	305	180	180	110	120	250	8	222.5	215	480	0.28	0.51	2LC0111-3AC	71
340	5500	2150	49	120	51	140	340	200	200	125	140	250	8	222.5	246	515	0.50	0.85	2LC0111-4AC	101
380	7700	2000	61	140	51	160	380	230	230	140	150	250	8	220.5	272	540	0.80	1.4	2LC0111-5AC	125
430	10300	1700	66	150	51	180	430	250	250	160	180	250	8	185.5	311	590	1.4	2.4	2LC0111-6AC	195
472	13500	1550	80	160	51	190	472	265	265	180	180	250	10	182	354	610	2.1	4.0	2LC0111-7AC	224

Configurable variants¹⁾

- ØD1 Without finished bore
With finished bore
- ØD2 Without finished bore
With finished bore

Notes

- For dimension U1, see type ADS on page 7/32 and type BDS on page 7/33.
- During assembly, the gap dimension S2 must not exceed the permissible tolerance of +1 mm.
- For sizes 305 to 472 the outer diameter of part 5 and part 7 is smaller than ØDA.
- Weights and mass moments of inertia apply to maximum bores.

Ordering example

- N-EUPEX HDS coupling, size 103, S = 100 mm
- Part 1: Bore D1 42H7 mm, keyway to DIN 6885-1 and set screw
- Part 5: Bore D2 32H7 mm, keyway to DIN 6885-1 and set screw
- Coupling micro-balanced G6.3 at 1500 rpm in accordance with half parallel key standard

Article no.: **2LC0110-3AC99-0AA0-Z L0X+M0T+W02+Y95**
Plain text to Y95: G=6.3;n=1500rpm

¹⁾ To identify complete item numbers specifying the available finish boring options and – if necessary – further order options, please use our configurators on flender.com.

↗ For online configuration on flender.com, click on the item no.

SPARE AND WEAR PARTS

Elastomer flexibles of the N-EUPEX series

NBR elastomer flexibles 80 ShoreA standard type			
Size	Article No. (flexible set for one coupling)	Number of flexibles per set	Weight per set kg
58	2LC0170-0WA00-0AA0	4	0.012
68	2LC0170-1WA00-0AA0	5	0.015
80	2LC0170-2WA00-0AA0	6	0.02
95	2LC0170-3WA00-0AA0	6	0.03
110	2LC0170-4WA00-0AA0	6	0.045
125	2LC0170-5WA00-0AA0	6	0.06
140	2LC0170-6WA00-0AA0	6	0.09
160	2LC0170-7WA00-0AA0	7	0.12
180	2LC0170-8WA00-0AA0	8	0.17
200	2LC0171-0WA00-0AA0	8	0.23
225	2LC0171-1WA00-0AA0	8	0.3
250	2LC0171-2WA00-0AA0	8	0.38
280	2LC0171-3WA00-0AA0	8	0.55
315	2LC0171-4WA00-0AA0	9	0.7
350	2LC0171-5WA00-0AA0	9	0.85
400	2LC0171-6WA00-0AA0	10	1.2
440	2LC0171-7WA00-0AA0	10	1.5
480	2LC0171-8WA00-0AA0	10	2.1
520	2LC0172-0WA00-0AA0	10	2.6
560	2LC0172-1WA00-0AA0	10	3.6
610	2LC0172-2WA00-0AA0	10	4.9
660	2LC0172-3WA00-0AA0	10	6.3
710	2LC0172-4WA00-0AA0	10	7.6

HP elastomer flexibles for type DK/DKS (two-joint)			
Size	Article No. (flexible set for one coupling)	Number of flexibles per set	Weight per set kg
68	2LC0170-1VD00-0AA0	10	0.03
80	2LC0170-2VD00-0AA0	12	0.04
95	2LC0170-3VD00-0AA0	12	0.06
110	2LC0170-4VD00-0AA0	12	0.09
125	2LC0170-5VD00-0AA0	12	0.12
140	2LC0170-6VD00-0AA0	12	0.18
160	2LC0170-7VD00-0AA0	14	0.24
180	2LC0170-8VD00-0AA0	16	0.34
200	2LC0171-0VD00-0AA0	16	0.46
225	2LC0171-1VD00-0AA0	16	0.6
250	2LC0171-2VD00-0AA0	16	0.8
280	2LC0171-3VD00-0AA0	16	1.1

Notes

- The elastomer flexibles are wear parts. The service life depends on the operating conditions.

Elastomer flexibles of the N-EUPEX DS series

NBR elastomer flexibles standard type			
Size	Article No. (flexible set for one coupling)	Number of flexibles per set	Weight per set kg
66	2LC0110-0WA00-0AA0	4	0.012
76	2LC0110-1WA00-0AA0	5	0.015
88	2LC0110-2WA00-0AA0	6	0.021
103	2LC0110-3WA00-0AA0	6	0.033
118	2LC0110-4WA00-0AA0	6	0.048
135	2LC0110-5WA00-0AA0	6	0.072
152	2LC0110-6WA00-0AA0	6	0.1
172	2LC0110-7WA00-0AA0	7	0.16
194	2LC0110-8WA00-0AA0	8	0.21
218	2LC0111-0WA00-0AA0	8	0.28
245	2LC0111-1WA00-0AA0	8	0.45
272	2LC0111-2WA00-0AA0	8	0.64
305	2LC0111-3WA00-0AA0	8	0.72
340	2LC0111-4WA00-0AA0	9	0.92
380	2LC0111-5WA00-0AA0	9	1.2
430	2LC0111-6WA00-0AA0	10	1.6
472	2LC0111-7WA00-0AA0	10	2.0
514	2LC0111-8WA00-0AA0	10	2.5
556	2LC0112-0WA00-0AA0	10	3.2

Notes

- The elastomer flexibles are wear parts. The service life depends on the operating conditions.

Friction linings of the N-EUPEX type ERN

Friction linings, standard version			
Size	Article No. (set for one coupling)	Number of friction linings per set	Weight per set kg
80	2LC0170-2VK00-0AA0	2	0.05
95	2LC0170-3VK00-0AA0	2	0.06
110	2LC0170-4VK00-0AA0	2	0.06
125	2LC0170-5VK00-0AA0	2	0.10
140	2LC0170-6VK00-0AA0	2	0.12
160	2LC0170-7VK00-0AA0	2	0.12
180	2LC0170-8VK00-0AA0	2	0.23
200	2LC0171-0VK00-0AA0	2	0.34
225	2LC0171-1VK00-0AA0	2	0.34
250	2LC0171-2VK00-0AA0	2	0.60
280	2LC0171-3VK00-0AA0	2	0.66

Notes

- The friction linings are wear parts. The service life depends on the operating conditions.

FLEXIBLE COUPLINGS RUPEX SERIES

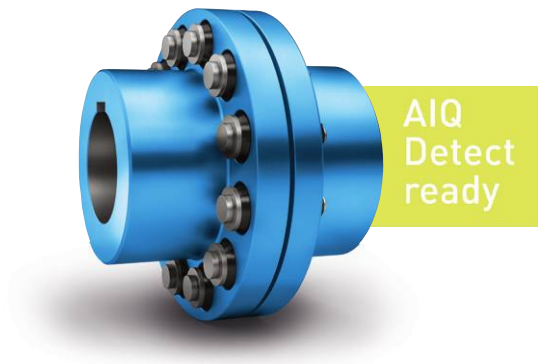

General	8/3
Benefits	8/3
Application	8/3
Design and configurations	8/4
Function	8/6
Technical specifications	8/6
<hr/>	
Type RWN – Hub material grey cast iron	8/8
Type RWS – Hub material steel	8/10
Type RFN – Hub material grey cast iron	8/12
Type RFS – Hub material steel	8/14
Type RWB – with brake disk to DIN 15432	8/16
Type RBS – with brake disk to DIN 15432	8/18
Type RWB – with brake drum to DIN 15431	8/22
Type RBS – with brake drum to DIN 15431	8/23
Spare and wear parts	8/24



GENERAL

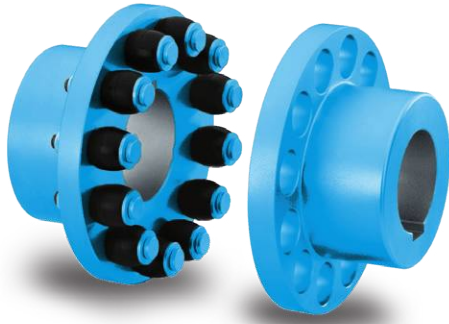

RUPEX pin and bush couplings link machine shafts and compensate for shaft misalignment with weak restorative forces. The torque is conducted through elastomer buffers, so the coupling has typically flexible rubber properties.

Benefits

RUPEX couplings can also hold loads when overloaded and are therefore especially suitable for drives for special safety and reliability requirements.

Torque shock loads and changing loads are no problem for robust, compact flexible RUPEX couplings.

The steel variant is also especially suitable for high-speed drives.

Application

RUPEX couplings are available as a catalog standard in 26 sizes with a rated torque of between 200 Nm and 1690000 Nm.

The coupling is suitable for use at ambient temperatures of between -30 °C and +80 °C. By using alternative elastomer buffers, the permissible ambient temperature range can be extended to between -50 °C and +100 °C.



Coupling suitable for use in potentially explosive atmospheres.

Complies with the current ATEX Directive for:

CE  II 2G Ex h IIC T6 ... T4 Gb X

 II 2D Ex h IIIC T85 °C ... 110 °C Db X

 I M2 Ex h Mb X

Thanks to their robust design, RUPEX couplings are also suitable for rough operating conditions.

RUPEX couplings are fitted by putting together the coupling halves. Fitting with low torsional backlash is simplified by the barrel-shaped geometry of the buffers.

RUPEX couplings require little maintenance. Only the elastomer buffers, as wear parts, need be replaced and the coupled machines need not be moved to do so.

RUPEX couplings are suitable for reversing operation and horizontal and vertical fitting or fitting at any required angle.

Frequently, the coupling is used to connect the gear shaft to the driven machine. In the case of drives without gear units, the coupling is particularly suitable for operation in rough conditions or heavy-duty drives with electric motor drive. Ventilator drives with high ventilator mass and drives in the cement industry are typical applications.

Examples of particularly safety-relevant areas of application are cable railway drives, lifting gear for crane drives or escalator drives.

GENERAL

Design and configurations

A RUPEX coupling comprises two hub sections which are mounted on the machine shafts. The hub parts are connected positively by steel pins and elastomer buffers. The coupling can be fitted with add-on parts such as brake disks or brake drums.

Up to size 360, the pins and buffers are fitted on one side. From size 400 up, the pins and buffers are fitted in the hubs on alternate sides.

Materials

- Hubs:
Types RWN and RWB made of grey cast iron EN-GJL-250
Types RWS and RBS made of steel
- Flange:
Types RFN, RFS made of steel
- Pins:
Material steel 42CrMo4, surface fine-machined

- Brake disks:
Type RWB made of EN-GJS-400 spheroidal graphite cast iron
Type RBS made of steel
- Brake drums:
Type RWB made of EN-GJL-250 grey cast iron
Type RBS made of steel

8

Buffer material

Material/description	Hardness	Marking	Ambient temperature
NBR standard type	80 ShoreA	Buffer black	-30 °C ... +80 °C
NBR electrically insulating	80 ShoreA	Buffer green	-30 °C ... +80 °C
NBR soft	65 ShoreA	Buffer black with green dot	-30 °C ... +80 °C
NBR hard	90 ShoreA	Buffer black with magenta dot	-30 °C ... +80 °C
NR for low temperature	80 ShoreA	Buffer black with white dot	-50 °C ... +50 °C
HNBR high temperature	80 ShoreA	Buffer black with red dot	-10 °C ... +100 °C

RUPEX pin and bush coupling types

Type	Description
RWN	Coupling made of grey cast iron
RWS	Coupling made of steel
RWB	Coupling made of grey cast iron with brake drum or brake disk
RBS	Coupling made of steel with brake drum or brake disk
RFN	Coupling made of grey cast iron in flange-shaft variant
RFS	Coupling made of steel in flange-shaft variant

Further application-related coupling types are available. Dimension sheets for and information on these are available on request.

RUPEX pin and bush coupling types on request

Type	Description
All	Coupling with axial backlash limitation
	Coupling with pretensioned buffers
	Coupling with lengthened pins and spacer sleeves
RKS	Coupling for engaging/disengaging during standstill
RWNH, RWSH	Coupling with extension piece
RBM	Coupling with lengthened pins for sliding rotor motors
RAK	Coupling combination RUPEX with ARPEX all-steel membrane coupling

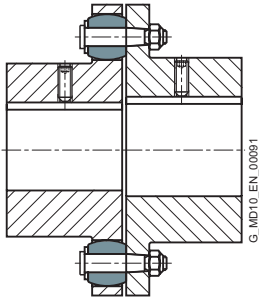

up to size 360

Types RWN/RWS – One-sided arrangement of pins and buffers

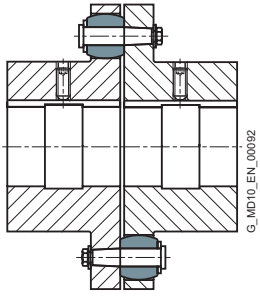

from size 400

Types RWN/RWS – Alternate-sided arrangement of pins and buffers

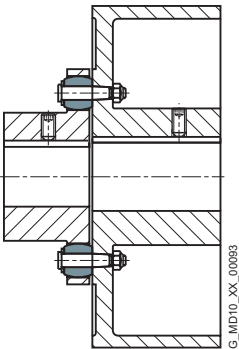

Types RWB/RBS with brake drum

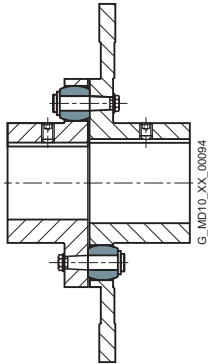

Types RWB/RBS with brake disk

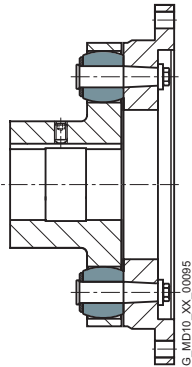

Types RFN, RFS

GENERAL

Function

The motor torque is transmitted to the hub on the drive side via the shaft-hub connection, which is mostly designed as a keyway connection. With the aid of elastomer buffers mounted on steel pins, the torque is conducted to the hub on the output side. The hub on the output side

further transmits the torque to the driven machine or a gear unit located in between. Because of the primarily compression-loaded buffers, the coupling has a progressive torsional stiffness.

Technical specifications

Size	Rated torque for buffer type		Maximum torque for buffer type		Torsional stiffness at 50 % capacity utilization for buffer type			Assembly Gap dimension ΔS mm	Permitted shaft misalignment at n = 1500 rpm ¹⁾	
	65 ShoreA	80/90 ShoreA	65 ShoreA	80/90 ShoreA	65 ShoreA	80 ShoreA	90 ShoreA		Radial ΔK _r mm	Angle ΔK _w Degree
	T _{KN} Nm	T _{KN} ²⁾ Nm	T _{Kmax} Nm	T _{Kmax} Nm	C _{Tdyn 50 %} kNm/rad	C _{Tdyn 50 %} kNm/rad	C _{Tdyn 50 %} kNm/rad			
105	120	200	360	600	5	13	21	1	0.21	0.12
125	210	350	630	1050	9	25	37	1	0.23	0.11
144	300	500	900	1500	15	43	64	1	0.25	0.1
162	450	750	1350	2250	20	55	83	1.5	0.27	0.1
178	570	950	1710	2850	31	85	130	1.5	0.29	0.09
198	780	1300	2340	3900	43	123	187	1.5	0.3	0.09
228	1300	2200	3900	6600	65	184	270	1.5	0.34	0.09
252	1650	2750	4950	8250	92	256	380	1.5	0.36	0.08
285	2600	4300	7800	12900	141	390	560	1.5	0.4	0.08
320	3300	5500	9900	16500	195	540	790	1.5	0.43	0.08
360	4700	7800	14100	23400	276	610	940	1.5	0.48	0.08
400	7500	12500	22500	37500	410	1130	1710	1.5	0.52	0.07
450	11000	18500	33000	55500	570	1600	2380	1.5	0.57	0.07
500	15000	25000	45000	75000	860	2350	3600	1.5	0.62	0.07
560	23500	39000	70500	117000	1130	3070	4700	2	0.68	0.07
630	31000	52000	93000	156000	1640	4600	7400	2	0.75	0.07
710	50000	84000	150000	252000	2560	7200	10900	2	0.84	0.07
800	66000	110000	198000	330000	3900	10700	16700	2	0.93	0.07
900	90000	150000	270000	450000	5200	14300	22500	2.5	1.03	0.07
1000	115000	195000	345000	585000	7700	21300	33000	2.5	1.14	0.07
1120	160000	270000	480000	810000	9800	27300	44000	2.5	1.26	0.06
1250	205000	345000	615000	1035000	14000	39000	62000	2.5	1.39	0.06
1400	320000	530000	960000	1590000	22800	62000	97000	3	1.55	0.06
1600	450000	750000	1350000	2250000	37000	103000	160000	3	1.76	0.06
1800	585000	975000	1755000	2925000	48000	133000	208000	4	1.96	0.06
2000	780000	1300000	2340000	3900000	73000	201000	314000	4	2.17	0.06

For coupling fatigue torque:

$$T_{KW} = 0,20 \cdot T_{KN}$$

Note

For fitting, the maximum gap dimension of S max. = S + ΔS and the minimum gap dimension of S min. = S - ΔS are permitted.

¹⁾ The maximum speed for the respective type must be noted. For additional information on the allowable shaft misalignment, please refer to the operating instructions.

²⁾ Higher rated torque permitted for steel hubs with buffer version 90 Shore A. See information in the type tables for details.

Torsional stiffness and damping

The values stated in the above table apply to a capacity utilization of 50 %, an excitation amplitude of 10 % T_{KN} with the frequency 10 Hz and an ambient temperature of 20 °C. The dynamic torsional stiffness is load-dependent and increases in proportion to capacity utilization. The following table shows the correction factors for different rated loads.

$$C_{Tdyn} = C_{Tdyn} 50 \% \cdot FKC$$

	Load T_N / T_{KN}							
	20%	40%	50%	60%	70%	80%	90%	100%
Correction factor FKC 65/80/90 ShoreA	0.51	0.83	1	1.18	1.38	1.58	1.8	2.03

The damping coefficient is $\Psi = 1.4$

Torsional stiffness and damping is further dependent on the ambient temperature and the frequency and amplitude of the torsional vibration excitation. More precise torsional stiffness and damping parameters on request.

With flexible couplings the manufacturing process of the rubber elements and their aging primarily influence the stiffness value C_{Tdyn} . For this reason calculation must be made with a tolerance for the dynamic stiffness of ± 20 %. The specified damping coefficient Ψ is a minimum value with the result that the damping performance of the coupling corresponds at least to the specified value.

Permitted shaft misalignment

The permitted shaft misalignment depends on the operating speed. As the speed increases, lower shaft misalignment values are permitted. The correction factors for different speeds are specified in the following table. The maximum speed for the respective coupling size and type must be noted!

$$\Delta K_{perm} = \Delta K_{1500} \cdot FKV$$

	Speed in rpm			
	500	1000	1500	3000
Correction factor FKV	1.7	1.2	1.0	0.7

For fitting, the maximum gap dimension of $S_{max.} = S + \Delta S$ and the minimum gap dimension of $S_{min.} = S - \Delta S$ are permitted.

Shaft misalignments ΔK_r and ΔK_w may occur simultaneously.

TYPE RWN

Hub material grey cast iron

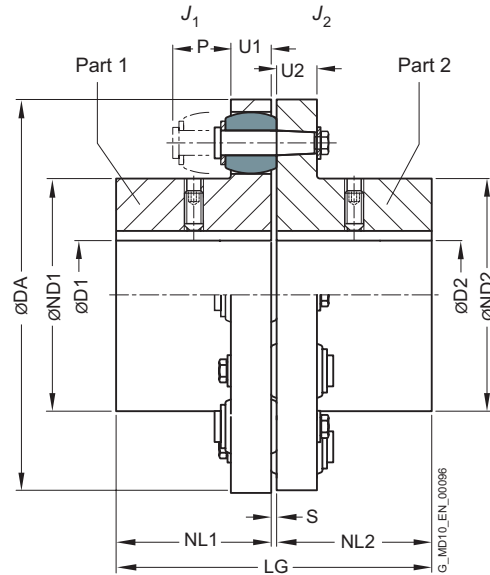

8

Size	Rated torque buffer 80 ShoreA T_{KN} Nm	Speed n_{Kmax} rpm	Dimensions in mm													Mass moment of inertia		Article no. ¹⁾	Weight m kg
			Bore with keyway DIN 6885-1 D1		D2		DA	ND1	ND2	NL1/ NL2	S	U1	U2	P	LG	J_1 kgm ²	J_2 kgm ²		
			min.	max.	min.	max.													
105 ²⁾	200	7000	-	35	-	42	105	53	59	45	3	13	12	30	93	0.001	0.001	2LC0130-1AA	1.8
125 ²⁾	350	6000	-	42	-	48	125	65	68	50	3	16	15	35	103	0.003	0.003	2LC0130-2AA	3.2
144	500	5250	-	48	-	60	144	76	84	55	3	16	15	35	113	0.004	0.006	2LC0130-3AA	4.2
162	750	4650	-	55	-	65	162	85	92	60	3.5	20	18	40	123.5	0.007	0.013	2LC0130-4AA	6.3
178	950	4200	-	70	-	75	178	102	108	70	3.5	20	18	40	143.5	0.013	0.022	2LC0130-5AA	8.9
198	1300	3750	-	80	-	90	198	120	128	80	3.5	20	18	40	163.5	0.021	0.029	2LC0130-6AA	11.5
228	2200	3300	-	90	-	95	228	129	140	90	3.5	26	24	50	183.5	0.036	0.070	2LC0130-7AA	17.7
252	2750	3000	-	100	-	110	252	150	160	100	3.5	26	24	50	203.5	0.068	0.12	2LC0130-8AA	24
285	4300	2650	48	110	48	120	285	164	175	110	4.5	32	30	60	224.5	0.13	0.22	2LC0131-0AA	36
320	5500	2350	55	120	55	130	320	180	192	125	4.5	32	30	60	254.5	0.22	0.29	2LC0131-1AA	50
360	7800	2100	65	130	65	140	360	200	210	140	4.5	42	42	75	284.5	0.40	0.69	2LC0131-2AA	74
400	12500	2050	75	150	75	150	400	230	230	160	4.5	42	42	75	324.5	0.86	0.86	2LC0131-3AA	100
450	18500	1800	85	170	85	170	450	260	260	180	5.5	52	52	90	365.5	1.7	1.7	2LC0131-4AA	149
500	25000	1600	95	190	95	190	500	290	290	200	5.5	52	52	90	405.5	2.8	2.8	2LC0131-5AA	192
560	39000	1500	100	140	100	140	560	250	250	220	6	68	68	120	446	4.6	4.6	2LC0131-6AA	280
			140	180	140	180		300	300							5	5		290
			180	200	180	200		320	320							5.1	5.1		295
630	52000	1280	100	140	100	140	630	250	250	240	6	68	68	120	486	7.2	7.2	2LC0131-7AA	345
			140	180	140	180		300	300							7.7	7.7		370
			180	220	180	220		355	355							8.4	8.4		400
710	84000	1150	110	160	110	160	710	290	290	260	7	80	80	140	527	13	13	2LC0131-8AA	510
			160	200	160	200		330	330							14	14		515
			200	240	200	240		385	385							15	15		540

Configurable variants ¹⁾

- ØD1 Without finished bore
With finished bore
- ØD2 Without finished bore
With finished bore

¹⁾ To identify complete item numbers specifying the available finish boring options and – if necessary – further order options, please use our configurators on flender.com.

²⁾ Hub material spheroidal graphite iron EN-GJS 400.

➤ For online configuration on flender.com, click on the item no.

Size	Rated torque buffer 80 ShoreA T_{KN} Nm	Speed n_{Kmax} rpm	Dimensions in mm												Mass moment of inertia		Article no. ¹⁾	Weight m kg	
			Bore with keyway DIN 6885-1				DA	ND1	ND2	NL1/NL2	S	U1	U2	P	LG	J_1 kgm ²			J_2 kgm ²
			min.	max.	min.	max.													
800	110000	1000	125	180	125	180	800	320	320	290	7	80	80	140	587	22	22	2LC0132-0AA	670
			180	220	180	220		360	360							23	23		690
			220	260	220	260		420	420							24.5	24.5		730
900	150000	900	140	220	140	220	900	360	360	320	7.5	90	90	160	647.5	39	39	2LC0132-1AA	940
			220	260	220	260		425	425							41	41		960
			260	290	260	290		465	465							43	43		1030
1000	195000	810	150	240	150	240	1000	395	395	350	7.5	90	90	160	707.5	60	60	2LC0132-2AA	1200
			240	280	240	280		460	460							63	63		1250
			280	320	280	320		515	515							68	68		1310
1120	270000	700	160	200	160	200	1120	360	360	380	8.5	100	100	180	768.5	98	98	2LC0132-3AA	1470
			200	250	200	250		410	410							100	100		1510
			250	300	250	300		495	495							105	105		1600
1250	345000	650	300	350	300	350	1250	560	560	420	8.5	100	100	180	848.5	110	110	2LC0132-4AA	1690
			180	230	180	230		410	410							150	150		1850
			230	280	230	280		460	460							155	155		1900
1400	530000	570	280	330	280	330	1400	540	540	480	9	120	120	210	969	165	165	2LC0132-5AA	2025
			330	380	330	380		610	610							175	175		2210
			200	260	200	260		465	465							290	290		2820
1600	750000	500	260	320	260	320	1600	525	525	540	9	120	120	210	1089	300	300	2LC0132-6AA	2900
			320	380	320	380		620	620							310	310		3180
			380	440	380	440		700	700							330	330		3260
1800	975000	450	440	480	440	480	1800	565	565	600	12	140	140	240	1212	490	490	2LC0132-7AA	3780
			320	380	320	380		625	625							500	500		3870
			380	440	380	440		720	720							530	530		4150
2000	1300000	400	440	500	440	500	2000	770	770	660	12	140	140	240	1332	550	550	2LC0132-8AA	4290
			320	380	320	380		660	660							850	850		5550
			440	500	440	500		720	720							930	930		5630
2000	1300000	400	500	560	500	560	2000	820	820	660	12	140	140	240	1332	980	980	2LC0132-8AA	6000
			500	560	500	560		870	870							1050	1050		6250
			560	600	560	600		760	760							1350	1350		6800
2000	1300000	400	440	500	440	500	2000	820	820	660	12	140	140	240	1332	1400	1400	2LC0132-8AA	7000
			500	560	500	560		920	920							1500	1500		7350
			560	600	560	600		960	960							1550	1550		7620

Configurable variants¹⁾

- ØD1 Without finished bore
With finished bore
- ØD2 Without finished bore
With finished bore

Notes

- The hub diameter of the component part is assigned according to the diameter of the finished bore. Where bore diameters overlap, the component with the smaller hub diameter is always selected.
- Weight and mass moments of inertia apply to maximum bore diameters.
- The article numbers apply to standard buffers of NBR material in the 80 ShoreA variant; the article number for alternative buffer types is available on request.

Ordering example

- RUPEX RWN coupling, size 710
- Part 1: Hub left with bore 180H7 mm, with keyway to DIN 6885-1 and set screw
- Part 2: Hub right with bore 200H7 mm, with keyway to DIN 6885-1 and set screw.

Article no.: 2LC0131-8AA99-0AA0 L2B+M2D

¹⁾ To identify complete item numbers specifying the available finish boring options and – if necessary – further order options, please use our configurators on flender.com.

➤ For online configuration on flender.com, click on the item no.

TYPE RWS

Hub material steel

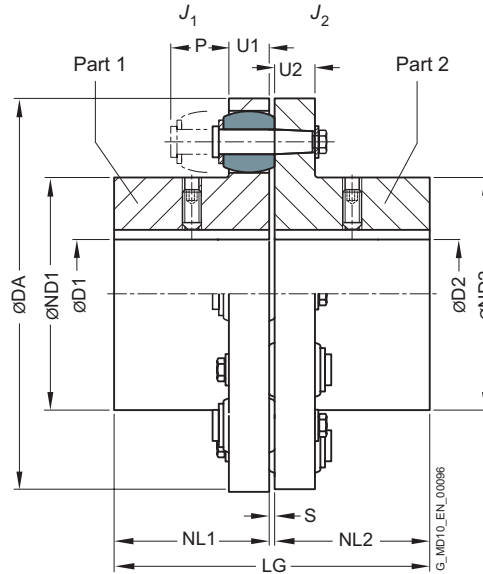

8

Size	Rated torque		Speed n_{Kmax} rpm	Dimensions in mm													Mass moment of inertia		Article no. ²⁾	Weight m kg
	buffer 90 ShoreA $T_{KN}^{1)}$ Nm	buffer 80 ShoreA T_{KN} Nm		Bore with keyway DIN 6885-1 D1				DA	ND1	ND2	NL1/ NL2	S	U1	U2	P	LG	J_1 kgm ²	J_2 kgm ²		
				min.	max.	min.	max.													
105	260	200	10000	-	38	-	42	105	53	59	45	3	13	12	30	93	0.001	0.001	2LC0130-1AB	1.7
125	450	350	9000	-	48	-	50	125	65	68	50	3	16	15	35	103	0.003	0.003	2LC0130-2AB	3.0
144	650	500	7800	-	55	-	60	144	76	84	55	3	16	15	35	113	0.004	0.006	2LC0130-3AB	4.3
162	950	750	6900	-	60	-	65	162	85	92	60	3.5	20	18	40	123.5	0.007	0.013	2LC0130-4AB	6.5
178	1200	950	6300	-	75	-	80	178	102	108	70	3.5	20	18	40	143.5	0.014	0.021	2LC0130-5AB	9.1
198	1700	1300	5600	-	90	-	95	198	120	128	80	3.5	20	18	40	163.5	0.020	0.028	2LC0130-6AB	11.2
228	2850	2200	4900	-	95	-	100	228	129	140	90	3.5	26	24	50	183.5	0.036	0.070	2LC0130-7AB	17.5
252	3550	2750	4400	-	110	-	120	252	150	160	100	3.5	26	24	50	203.5	0.066	0.115	2LC0130-8AB	23.6
285	5600	4300	3900	-	120	-	130	285	164	175	110	4.5	32	30	60	224.5	0.12	0.21	2LC0131-0AB	36
320	7150	5500	3500	55	130	55	140	320	180	192	125	4.5	32	30	60	254.5	0.23	0.29	2LC0131-1AB	50
360	10000	7800	3100	65	145	65	150	360	200	210	140	4.5	42	42	75	284.5	0.40	0.69	2LC0131-2AB	73
400	16000	12500	2800	75	170	75	170	400	230	230	160	4.5	42	42	75	324.5	0.83	0.83	2LC0131-3AB	97
450	24000	18500	2500	85	190	85	190	450	260	260	180	5.5	52	52	90	365.5	1.6	1.6	2LC0131-4AB	147
500	32500	25000	2200	95	215	95	215	500	290	290	200	5.5	52	52	90	405.5	2.7	2.7	2LC0131-5AB	192
560	50500	39000	2000	100	165	100	165		250	250						4.8	4.8	2LC0131-6AB	274	
				165	200	165	200	560	300	300	220	6	68	68	120	446	5.2		5.2	292
				200	240	200	240		320	320							5.2		5.2	268
630	67500	52000	1800	100	165	100	165		250	250					7.6	7.6	2LC0131-7AB	352		
				165	200	165	200	630	300	300	240	6	68	68	120	486		7.9	7.9	370
				200	265	200	265		355	355								8.4	8.4	356
710	109000	84000	1600	110	190	110	190		290	290					14.4	14.4	2LC0131-8AB	507		
				190	220	190	220	710	330	330	260	7	80	80	140	527		14.6	14.6	530
				220	280	220	280		385	385								15.5	15.5	509

Configurable variants ²⁾

- ØD1 Without finished bore
With finished bore
- ØD2 Without finished bore
With finished bore

²⁾ To identify complete item numbers specifying the available finish boring options and – if necessary – further order options, please use our configurators on flender.com.

↗ For online configuration on flender.com, click on the item no.

¹⁾ T_{Kmax} is given in the specifications on Page 8/6.
 T_{KW} is determined from the specifications given on Page 8/6.

Size	Rated torque		Speed n_{Kmax} rpm	Dimensions in mm											Mass moment of inertia		Article no. ²⁾	Weight m kg		
	buffer 90 ShoreA $T_{KN}^{1)}$ Nm	buffer 80 ShoreA T_{KN} Nm		Bore with keyway DIN 6885-1				DA	ND1	ND2	NL1/ NL2	S	U1	U2	P	LG			J_1 kgm ²	J_2 kgm ²
				D1		D2														
800	143000	110000	1400	125	210	125	210	800	320	320	290	7	80	80	140	587	23.1	23.1	2LC0132-0AB	683
				210	240	210	240		360	360							23.3	23.3		715
				240	310	240	310		420	420							25.0	25.0		699
900	195000	150000	1250	140	210	140	210	900	320	320	320	7.5	90	90	160	647.5	40	40	2LC0132-1AB	907
				210	240	210	240		360	360							41	41		933
				240	280	240	280		425	425							44	44		1000
				280	340	280	340		465	465							44	44		948
1000	250000	195000	1100	150	230	150	230	1000	355	355	350	7.5	90	90	160	707.5	63	63	2LC0132-2AB	1170
				230	260	230	260		395	395							64	64		1208
				260	300	260	300		460	460							68	68		1290
				300	380	300	380		515	515							68	68		1220
1120	350000	270000	1000	160	240	160	240	1120	360	360	380	8.5	100	100	180	768.5	105	105	2LC0132-3AB	1560
				240	270	240	270		410	410							106	106		1660
				270	330	270	330		495	495							109	109		1730
				330	410	330	410		560	560							116	116		1720
1250	450000	345000	900	180	270	180	270	1250	410	410	420	8.5	100	100	180	848.5	168	168	2LC0132-4AB	2000
				270	300	270	300		460	460							172	172		2150
				300	360	300	360		540	540							179	179		2200
				360	440	360	440		610	610							185	185		2250
1400	690000	530000	800	200	310	200	310	1400	465	465	480	9	120	120	210	969	316	316	2LC0132-5AB	3020
				310	350	310	350		525	525							322	322		3120
				350	410	350	410		620	620							337	337		3350
				410	510	410	510		700	700							349	349		3280
1600	975000	750000	700	260	370	260	370	1600	565	565	540	9	120	120	210	1089	540	540	2LC0132-6AB	3890
				370	410	370	410		625	625							554	554		4270
				410	480	410	480		720	720							587	587		4300
				480	560	480	560		770	770							598	598		4270
1800	1260000	975000	600	320	440	320	440	1800	660	660	600	12	140	140	240	1212	1043	1043	2LC0132-7AB	6230
				440	480	440	480		720	720							1072	1072		6460
				480	540	480	540		820	820							1122	1122		6770
				540	650	540	650		870	870							1113	1113		6390
2000	1690000	1300000	550	380	500	380	500	2000	760	760	660	12	140	140	240	1332	1628	1628	2LC0132-8AB	8140
				500	540	500	540		820	820							1664	1664		8430
				540	610	540	610		920	920							1735	1735		8860
				610	710	610	710		960	960							1749	1749		8280

Configurable variants²⁾

- ØD1 Without finished bore
With finished bore
- ØD2 Without finished bore
With finished bore

Notes

- The hub diameter of the component part is assigned according to the diameter of the finished bore. Where bore diameters overlap, the component with the smaller hub diameter is always selected.
- Weight and mass moments of inertia apply to maximum bore diameters.
- The article numbers apply to standard buffers of NBR material in the 80 ShoreA variant; the article number for alternative buffer types is available on request.

Ordering example

- RUPEX RWS coupling, size 710
- Part 1: Hub left with bore 180H7 mm, with keyway to DIN 6885-1 and set screw
- Part 2: Hub right with bore 200H7 mm, with keyway to DIN 6885-1 and set screw.
- Coupling micro-balanced G 6.3 at 1500 rpm in accordance with half parallel key standard

Article no.: 2LC0131-8AB99-0AA0-Z L2B+M2D+W02+Y95
Plain text to Y95: G=6.3;n=1500rpm

¹⁾ T_{Kmax} is given in the specifications on Page 8/6.
 T_{KW} is determined from the specifications given on Page 8/6.

²⁾ To identify complete item numbers specifying the available finish boring options and – if necessary – further order options, please use our configurators on flender.com.

↗ For online configuration on flender.com, click on the item no.

TYPE RFN

Hub material grey cast iron

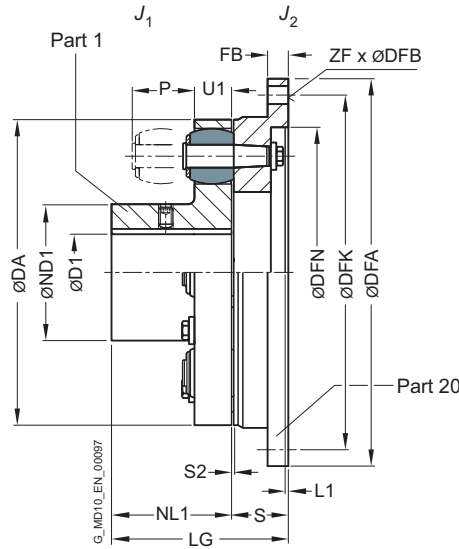

8

Size	Rated torque buffer 80 ShoreA T_{KN} Nm	Speed n_{Kmax} rpm	Dimensions in mm													Mass moment of inertia		Article no. ¹⁾	Weight m kg			
			Bore with keyway DIN 6885-1 D1 min. max.		DA	ND1	NL1	S	LG	Flange connection						J_1 kgm ²	J_2 kgm ²					
105	200	7000	-	35	105	53	45	26	71	158	10					142	6	9	0.001	0.005	2LC0130-1AJ	2.2
125	350	6000	-	42	125	65	50	31	81	180	13					160	6	11	0.003	0.012	2LC0130-2AJ	4.1
144	500	5250	-	48	144	76	55	31	86	200	13					180	7	11	0.004	0.018	2LC0130-3AJ	4.9
162	750	4650	-	55	162	85	60	37.5	97.5	220	13					200	8	11	0.007	0.032	2LC0130-4AJ	7.1
178	950	4200	-	70	178	102	70	37.5	107.5	248	16					224	8	14	0.013	0.055	2LC0130-5AJ	9
198	1300	3750	-	80	198	120	80	37.5	117.5	274	16					250	8	14	0.021	0.08	2LC0130-6AJ	12
228	2200	3300	-	90	228	129	90	45.5	135.5	314	20					282	8	18	0.036	0.18	2LC0130-7AJ	19
252	2750	3000	-	100	252	150	100	45.5	145.5	344	20					312	8	18	0.068	0.26	2LC0130-8AJ	24
285	4300	2650	48	110	285	164	110	55.5	165.5	380	22					348	9	18	0.13	0.46	2LC0131-0AJ	37
320	5500	2350	55	120	320	180	125	55.5	175.5	430	25					390	9	22	0.22	0.76	2LC0131-1AJ	48
360	7800	2100	65	130	360	200	140	70.5	210.5	480	25					440	10	22	0.40	1.4	2LC0131-2AJ	74
400	12500	2050	75	150	400	230	160	74.5	234.5	520	50	380	4	480	10	22	26	0.86	1.8	2LC0131-3AJ	122	
450	18500	1800	85	170	450	260	180	85.5	265.5	575	45	428	6	528	12	26	26	1.7	3.2	2LC0131-4AJ	166	
500	25000	1600	95	190	500	290	200	85.5	285.5	620	45	475	6	570	12	26	26	2.8	4.3	2LC0131-5AJ	200	

Configurable variants ¹⁾

- ØD1 Without finished bore
With finished bore

¹⁾ To identify complete item numbers specifying the available finish boring options and – if necessary – further order options, please use our configurators on flender.com.

↗ For online configuration on flender.com, click on the item no.

Size	Rated torque buffer 80 ShoreA T_{KN} Nm	Speed n_{Kmax} rpm	Dimensions in mm													Mass moment of inertia		Article no. ¹⁾	Weight m kg		
			Bore with keyway DIN 6885-1 D1 min. max.		DA	ND1	NL1	S	LG	Flange connection						J_1 kgm ²	J_2 kgm ²				
560	39000	1500	100	140	560	250	220	106	326	700	65	532	8	650	16	26	4.6	8.2	2LC0131-6AJ	330	
			140	180		300											320			5	330
			180	200		320											5.1			340	
630	52000	1280	100	140	630	250	240	106	346	785	60	602	8	725	16	33	7.2	13.8	2LC0131-7AJ	390	
			140	180		300											355			7.7	400
			180	220		355											8.4			420	
710	84000	1150	110	160	710	290	260	127	387	875	80	675	10	815	18	33	13	26	2LC0131-8AJ	550	
			160	200		330											385			14	550
			200	240		385											15			570	
800	110000	1000	125	180	800	320	290	127	417	1000	70	765	10	930	16	39	22	45	2LC0131-9AJ	680	
			180	220		360											420			23	690
			220	260		420											24.5			710	

Configurable variants ¹⁾

- ØD1 Without finished bore
With finished bore

Notes

- For dimensions U1, P and S2, see type RWN on Page 8/8
- Weight and mass moments of inertia apply to maximum bore diameters.
- The article numbers apply to standard buffers of NBR material in the 80 ShoreA variant; the article number for alternative buffer types is available on request.

Ordering example

- RUPEX RFN coupling, size 560
- Part 1: Hub left with bore 180H7 mm, with keyway to DIN 6885-1 and set screw

Article no.: 2LC0131-6AJ91-0AA0 L2B

¹⁾ To identify complete item numbers specifying the available finish boring options and – if necessary – further order options, please use our configurators on flender.com.

➤ For online configuration on flender.com, click on the item no.

TYPE RFS

Hub material steel

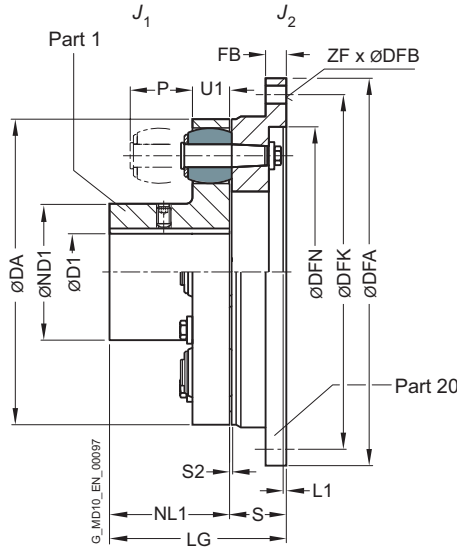

8

Size	Rated torque		Speed	Dimensions in mm												Mass moment of inertia		Article no. ²⁾	Weight		
	buffer 90 ShoreA	buffer 80 ShoreA		Bore with keyway DIN 6885-1					Flange connection							J_1	J_2				
	$T_{KN}^{1)}$ Nm	T_{KN} Nm	n_{Kmax} rpm	D1	DA	ND1	NL1	S	LG	DFA	FB	DFN	L1	DFK	ZF	DFB	kgm ²	kgm ²		m	
				min.	max.					h8		H7								kg	
105	260	200	10000	-	38	105	53	45	26	71	158	10		142	6	9	0.001	0.005	2LC0130-1AK	2.2	
125	450	350	9000	-	48	125	65	50	31	81	180	13		160	6	11	0.003	0.012	2LC0130-2AK	4.0	
144	650	500	7800	-	55	144	76	55	31	86	200	13		180	7	11	0.004	0.018	2LC0130-3AK	4.8	
162	950	750	6900	-	60	162	85	60	37.5	97.5	220	13		200	8	11	0.007	0.032	2LC0130-4AK	7.1	
178	1200	950	6300	-	75	178	102	70	37.5	107.5	248	16		224	8	14	0.014	0.055	2LC0130-5AK	10	
198	1700	1300	5600	-	90	198	120	80	37.5	117.5	274	16		250	8	14	0.020	0.08	2LC0130-6AK	12	
228	2850	2200	4900	-	95	228	129	90	45.5	135.5	314	20		282	8	18	0.036	0.18	2LC0130-7AK	19	
252	3550	2750	4400	-	110	252	150	100	45.5	145.5	344	20		312	8	18	0.066	0.26	2LC0130-8AK	24	
285	5600	4300	3900	48	120	285	164	110	55.5	165.5	380	22		348	9	18	0.12	0.46	2LC0131-0AK	36	
320	7150	5500	3500	55	130	320	180	125	55.5	175.5	430	25		390	9	22	0.23	0.76	2LC0131-1AK	49	
360	10000	7800	3100	65	145	360	200	140	70.5	210.5	480	25		440	10	22	0.40	1.4	2LC0131-2AK	74	
400	16000	12500	2800	75	170	400	230	160	74.5	234.5	520	50	380	4	480	10	22	0.83	1.8	2LC0131-3AK	119
450	24000	18500	2500	85	190	450	260	180	85.5	265.5	575	45	428	6	528	12	26	1.6	3.2	2LC0131-4AK	167
500	32500	25000	2200	95	215	500	290	200	85.5	285.5	620	45	475	6	570	12	26	2.7	4.3	2LC0131-5AK	198

Configurable variants ²⁾

- ØD1 Without finished bore
With finished bore

¹⁾ T_{Kmax} is given in the specifications on Page 8/6.

T_{KW} is determined from the specifications given on Page 8/6.

²⁾ To identify complete item numbers specifying the available finish boring options and – if necessary – further order options, please use our configurators on flender.com.

↗ For online configuration on flender.com, click on the item no.

Size	Rated torque		Speed n_{Kmax} rpm	Dimensions in mm														Mass moment of inertia		Article no. ²⁾	Weight m kg	
	buffer 90 ShoreA	buffer 80 ShoreA		Bore with keyway DIN 6885-1				Flange connection										J_1 kgm ²	J_2 kgm ²			
	$T_{KN}^{1)}$ Nm	T_{KN} Nm		D1 min.	D1 max.	DA	ND1	NL1	S	LG	DFA h8	FB	DFN H7	L1	DFK	ZF	DFB					
560	50500	39000	2000	100	165	560	250	300	220	106	326	700	65	532	8	650	16	26	4.8	8.2	2LC0131-6AK	330
				165	200		320												5.2			340
				200	240		320												5.2			320
630	67500	52000	1800	100	165	630	250	300	240	106	346	785	60	602	8	725	16	33	7.6	13.8	2LC0131-7AK	390
				165	200		355												7.9			400
				200	265		355												8.4			400
710	109000	84000	1600	110	190	710	290	330	260	127	387	875	80	675	10	815	18	33	14.4	26	2LC0131-8AK	550
				190	220		385												14.6			560
				220	280		385												15.5			555
800	143000	110000	1400	125	210	800	320	360	290	127	417	1000	70	765	10	930	16	39	23.1	45	2LC0131-9AK	690
				210	240		420												23.3			710
				240	310		420												25.0			700

Configurable variants ²⁾

- ØD1 Without finished bore
With finished bore

Notes

- For dimensions U1, P and S2, see type RWS on Page 8/10
- Weight and mass moments of inertia apply to maximum bore diameters.
- The article numbers apply to standard buffers of NBR material in the 80 ShoreA variant; the article number for alternative buffer types is available on request.

Ordering example

- RUPEX RFS coupling, size 560
- Part 1: Hub left with bore 180H7 mm, with keyway to DIN 6885-1 and set screw
- Coupling micro-balanced G 6.3 at 1500 rpm in accordance with half parallel key standard

Article no.: 2LC0131-6AK91-0AA0-Z L2B+W02+Y95
Plain text to Y95: G=6.3;n=1500rpm

¹⁾ T_{Kmax} is given in the specifications on Page 8/6.
 T_{KW} is determined from the specifications given on Page 8/6.

²⁾ To identify complete item numbers specifying the available finish boring options and – if necessary – further order options, please use our configurators on flender.com.

↗ For online configuration on flender.com, click on the item no.

TYPE RWB

with brake disk to DIN 15432

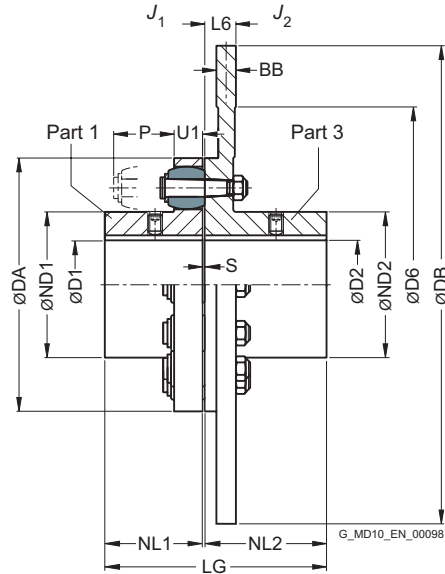

8

Size	Rated torque buffer 80 ShoreA T_{KN} Nm	Dimensions in mm																➤ Article no. ¹⁾		
		Bore with keyway DIN 6885-1												Brake disk						
		D1 min.	D1 max.	D2 min.	D2 max.	DA	ND1	ND2	NL1	NL2 max.	S	U1	P	LG max.	DB ²⁾ max.	DB min.	D6 min.		BB ²⁾	L6
144	500	-	48	-	45	144	76	84	55	219	3	16	35	277	500	315	175	30	34	2LC0130-3AE
162	750	-	55	-	50	162	85	92	60	219	3.5	20	40	282.5	560	315	175	30	34	2LC0130-4AE
178	950	-	70	-	60	178	102	108	70	219	3.5	20	40	292.5	560	355	200	30	34	2LC0130-5AE
198	1300	-	80	-	70	198	120	128	80	219	3.5	20	40	302.5	560	355	200	30	34	2LC0130-6AE
228	2200	-	90	-	80	228	129	140	90	219	3.5	26	50	312.5	800	355	250	30	34	2LC0130-7AE
252	2750	-	100	38	100	252	150	160	100	219	3.5	26	50	322.5	800	400	280	30	34	2LC0130-8AE
285	4300	48	110	48	110	285	164	175	110	219	4.5	32	60	333.5	800	400	310	30	34	2LC0131-0AE
320	5500	55	120	55	120	320	180	192	125	219	4.5	32	60	348.5	1000	450	350	30	34	2LC0131-1AE

Configurable variants ¹⁾

- ØD1 Without finished bore
With finished bore
- ØD2 With finished bore

¹⁾ To identify complete item numbers specifying the available finish boring options and – if necessary – further order options, please use our configurators on flender.com.

²⁾ For the available DB · BB brake disk dimensions, please refer to the product configurator on flender.com.

➤ For online configuration on flender.com, click on the item no.

Notes

- Brake disk diameter DB in accordance with customer specification.
 - Additional sizes are available on request.
 - Further dimensions for part 3 on request.
 - Maximum speed in rpm:
 $n_{K_{max}} = 1146/DB$ (DB in m)
 Observe maximum speed of type RWN!
 - Mass moments of inertia and weights can be sufficiently precisely determined as follows:
 - Mass moments of inertia in kgm^2 :
 $J_1 = J_1$ from type RWN
 $J_2 = J_2$ from type RWN + $710 \times BB \times DB^4$
 (BB and DB in m)
 - Weight in kg:
 $m = m$ from type RWN + $5700 \times BB \times DB^2$
 (BB and DB in m)
 - The article numbers apply to standard buffers of NBR material in the 80 ShoreA variant; the article number for alternative buffer types is available on request.
-

Ordering example

- RUPEX RWB coupling, size 252, brake disk 630 x 30 mm
 - Part 1: Bore D1 = 48H7 mm, keyway to DIN 6885-1 and set screw
 - Part 3: Bore 42H7 mm, keyway to DIN 6885-1 P9 and set screw.
 - Coupling micro-balanced G 6.3 at 1500 rpm in accordance with half parallel key standard
 - Mass moment of inertia:
 $J_1 = 0.07 \text{ kgm}^2$
 $J_2 = 0.12 \text{ kgm}^2 + 3.3 \text{ kgm}^2 = 3.42 \text{ kgm}^2$
 - Weight:
 $m = 26.3 \text{ kg} + 68 \text{ kg} = 94.3 \text{ kg}$
-

Article no.: 2LC0130-8AE99-0KA0-Z L1B+M0X+W02+Y95

Plain text to Y95: G=6.3;n=1500rpm

TYPE RBS

with brake disk to DIN 15432

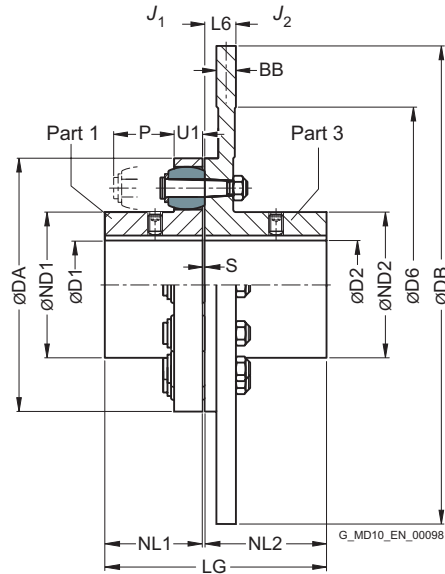

Size	Rated torque		Dimensions in mm																Article no. ²⁾		
	buffer 90 ShoreA	buffer 80 ShoreA	Bore with keyway DIN 6885-1				Shaft										Brake disk				
	$T_{KN}^{1)}$ Nm	T_{KN} Nm	D1 min.	D1 max.	D2 min.	D2 max.	DA	ND1	ND2	NL1	NL2 max.	S	U1	P	LG max.	DB ³⁾ min.	D6 min.	BB ³⁾		L6	
144	650	500	-	55	-	45	144	76	84	55	219	3	16	35	277	315	175	30	34	2LC0130-3AH	
162	950	750	-	60	-	50	162	85	92	60	219	3.5	20	40	282.5	315	175	30	34	2LC0130-4AH	
178	1200	950	-	75	-	60	178	102	108	70	219	3.5	20	40	292.5	355	200	30	34	2LC0130-5AH	
198	1700	1300	-	90	-	70	198	120	128	80	219	3.5	20	40	302.5	355	200	30	34	2LC0130-6AH	
228	2850	2200	-	95	-	80	228	129	140	90	219	3.5	26	50	312.5	355	250	30	34	2LC0130-7AH	
252	3550	2750	-	110	38	100	252	150	160	100	219	3.5	26	50	322.5	400	280	30	34	2LC0130-8AH	
285	5600	4300	48	120	48	120	285	164	175	110	219	4.5	32	60	333.5	400	310	30	34	2LC0131-0AH	
320	7150	5500	55	130	55	130	320	180	192	125	219	4.5	32	60	348.5	450	350	30	34	2LC0131-1AH	
360	10000	7800	65	145	65	140	360	200	210	140	221	4.5	42	75	365.5	560	390	30	36	2LC0131-2AE	

Configurable variants ²⁾

- ØD1 Without finished bore
With finished bore
- ØD2 With finished bore

¹⁾ T_{Kmax} is given in the specifications on Page 8/6.

T_{KW} is determined from the specifications given on Page 8/6.

²⁾ To identify complete item numbers specifying the available finish boring options and – if necessary – further order options, please use our configurators on flender.com.

³⁾ For the available DB- BB brake disk dimensions, please refer to the product configurator on flender.com.

↗ For online configuration on flender.com, click on the item no.

Notes

- Brake disk diameter DB in accordance with customer specification.
 - Additional sizes are available on request.
 - Further dimensions for part 3 on request.
 - Maximum speed in rpm:
 $n_{K_{max}} = 1528/DB$ (DB in m)
 Observe maximum speed of type RWS!
 - Mass moments of inertia and weights can be sufficiently precisely determined as follows:
 - Mass moments of inertia in kgm^2 :
 $J_1 = J_1$ from type RWS
 $J_2 = J_2$ from type RWS + $770 \times BB \times DB^4$
 (BB and DB in m)
 - Weight in kg:
 $m = m$ from type RWS + $6160 \times BB \times DB^2$
 (BB and DB in m)
 - The article numbers apply to standard buffers of NBR material in the 80 ShoreA variant; the article number for alternative buffer types is available on request.
-

Ordering example

- RUPEX RBS coupling, size 252, brake disk 630 x 30 mm
 - Part 1: Bore D1 = 48H7 mm, keyway to DIN 6885-1 and set screw
 - Part 3: Bore 42H7 mm, keyway to DIN 6885-1 P9 and set screw.
 - Coupling micro-balanced G 6.3 at 1500 rpm in accordance with the half parallel key standard.
 - Mass moment of inertia:
 $J_1 = 0.07 \text{ kgm}^2$
 $J_2 = 0.12 \text{ kgm}^2 + 3.6 \text{ kgm}^2 = 3.72 \text{ kgm}^2$
 - Weight:
 $m = 25.8 \text{ kg} + 73 \text{ kg} = 98.8 \text{ kg}$
-

Article no.: 2LC0130-8AH99-0KA0-Z L1B+M0X+W02+Y95
 Plain text to Y95: G=6.3;n=1500rpm

TYPE RBS

with brake disk to DIN 15432

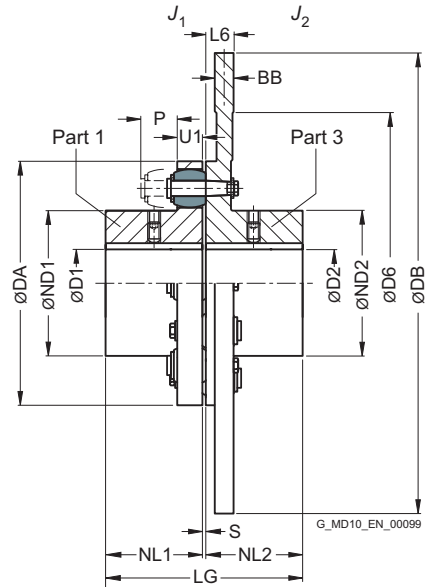

8

Size	Rated torque		Dimensions in mm													Brake disk			Article no. ¹⁾
	buffer 90 ShoreA T_{KN} Nm	buffer 80 ShoreA T_{KN} Nm	Bore with keyway DIN 6885-1				DA	ND1	ND2	NL1	NL2	S	U1	P	LG	D6 ²⁾ min.	BB ²⁾	L6	
			D1 min.	D1 max.	D2 min.	D2 max.													
400	16000	12500	75	170	75	150	400	230	230	160	225	4.5	42	75	389.5	410	30	40	2LC0131-3AH
450	24000	18500	85	190	85	170	450	260	260	180	225	5.5	52	90	410.5	460	30	40	2LC0131-4AH
500	32500	25000	95	215	95	190	500	290	290	200	225	5.5	52	90	430.5	510	30	40	2LC0131-5AH
560	50500	39000	100	165	100	210	560	250	320	220	225	6	68	120	451	570	30	40	2LC0131-6AH
			200	240				320											
630	67500	52000	100	165	100	235	630	250	355	240	240	6	68	120	486	670	30	55	2LC0131-7AH
			200	265				355											

Configurable variants ¹⁾

- ØD1 Without finished bore
With finished bore
- ØD2 With finished bore

¹⁾ To identify complete item numbers specifying the available finish boring options and – if necessary – further order options, please use our configurators on flender.com.

²⁾ For the available DB · BB brake disk dimensions, please refer to the product configurator on flender.com.

➤ For online configuration on flender.com, click on the item no.

Size	Rated torque		Dimensions in mm														Article no. ¹⁾		
	buffer 90 ShoreA T_{KN} Nm	buffer 80 ShoreA T_{KN} Nm	Bore with keyway DIN 6885-1												Brake disk				
			D1 min.	D1 max.	D2 min.	D2 max.	DA	ND1	ND2	NL1	NL2	S	U1	P	LG	D6 ²⁾ min.	BB ²⁾	L6	
710	109000	84000	110	190	110	250	710	290	385	260	260	7	80	140	527	760	30	75	2LC0131-8AH
			190	220				330											
			220	250				385											
800	143000	110000	125	210	125	280	800	320	420	290	290	7	80	140	587	840	30	75	2LC0132-0AH
			210	240				360											
			240	280				420											
900	195000	150000	140	210	140	310	900	320	465	320	-	7.5	90	160	647.5	950	30	75	2LC0132-1AH
			210	240				360											
			240	280				425											
1000	250000	195000	150	230	150	340	1000	355	515	350	-	7.5	90	160	707.5	1050	30	75	2LC0132-2AH
			230	260				395											
			260	300				460											
			300	340				515											

Configurable variants¹⁾

- ØD1 Without finished bore
With finished bore
- ØD2 With finished bore

Notes

- Brake disk diameter DB in accordance with customer specification.
- Additional sizes are available on request. Further dimensions for part 3 on request.
- Maximum speed in rpm:
 $n_{Kmax} = 1528/DB$ (DB in m)
Observe maximum speed of type RWS!
- Mass moments of inertia and weights can be sufficiently precisely determined as follows:
 - Mass moments of inertia in kgm²:
 $J_1 = J_1$ from type RWS
 $J_2 = J_2$ from type RWS + $770 \times BB \times DB^4$ (BB and DB in m)
 - Weight in kg:
 $m = m$ from type RWS + $6160 \times BB \times DB^2$ (BB and DB in m)
- The article numbers apply to standard buffers of NBR material in the 80 ShoreA variant; the article number for alternative buffer types is available on request.

Ordering example

- RUPEX RBS coupling, size 450, brake disk 900 x 30 mm
- Part 1: Bore D1 = 130H7 mm, keyway to DIN 6885-1 and set screw
- Part 3: Bore 120H7 mm, keyway to DIN 6885-1 P9 and set screw.
- Coupling micro-balanced G 6.3 at 1500 rpm in accordance with half parallel key standard
- Mass moment of inertia:
 $J_1 = 1.74 \text{ kgm}^2$
 $J_2 = 1.74 \text{ kgm}^2 + 15 \text{ kgm}^2 = 16.74 \text{ kgm}^2$
- Weight:
 $m = 25.8 \text{ kg} + 149 \text{ kg} = 174.8 \text{ kg}$

Article no.: 2LC0131-4AH99-0NA0-Z L1U+M1S+W02+Y95
Plain text to Y95: G=6.3;n=1500rpm

¹⁾ To identify complete item numbers specifying the available finish boring options and – if necessary – further order options, please use our configurators on flender.com.

²⁾ For the available DB·BB brake disk dimensions, please refer to the product configurator on flender.com.

➤ For online configuration on flender.com, click on the item no.

TYPE RWB

with brake drum to DIN 15431

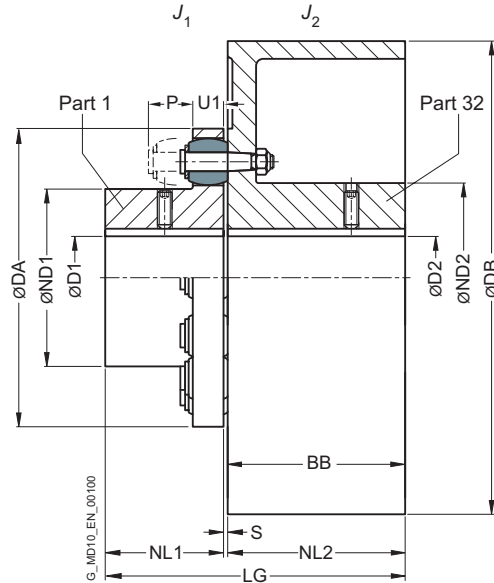

8

Size	Rated torque buffer 80 ShoreA T_{KN} Nm	Speed n_{Kmax} rpm	Dimensions in mm											Mass moment of inertia		Article no. ¹⁾	Weight m kg		
			Bore with keyway DIN 6885-1 D1			DA	ND1	ND2	NL1	NL2/ BB	S	DB	LG	J_1 kgm ²	J_2 kgm ²				
			min.	max.	min.	max.													
144	500	4800	-	48	-	55	144	76	84	55	75	3	200	133	133	0.004	0.04	2LC0130-3AC	9.4
162	750	3800	-	55	-	60	162	85	92	60	95	3.5	250	158.5	158.5	0.007	0.11	2LC0130-4AC	17
		3000	-	70	-	70	178	102	108	70	95	3.5	250	168.5	191.5	0.013	0.12	2LC0130-5AC	19
178	950	3800	-	70	-	70	178	102	108	70	95	3.5	250	168.5	191.5	0.013	0.12	2LC0130-5AC	27
		3000	-	80	-	80	198	120	128	80	95	3.5	250	178.5	201.5	0.021	0.13	2LC0130-6AC	23
198	1300	3800	-	80	-	80	198	120	128	80	95	3.5	250	178.5	201.5	0.021	0.13	2LC0130-6AC	31
		3000	-	90	-	90	228	129	140	90	118	3.5	315	201.5	243.5	0.036	1	2LC0130-7AC	53
228	2200	2400	-	90	-	90	228	129	140	90	150	3.5	400	243.5	243.5	0.036	1	2LC0130-7AC	53
		1900	-	100	38	100	252	150	160	100	150	3.5	400	253.5	293.5	0.068	1	2LC0130-8AC	62
252	2750	2400	-	100	38	100	252	150	160	100	150	3.5	400	253.5	293.5	0.068	1	2LC0130-8AC	92
		1900	-	110	48	110	285	164	175	110	190	4.5	500	304.5	304.5	0.13	2.8	2LC0130-8AC	92
285	4300	1900	48	110	48	110	285	164	175	110	190	4.5	500	304.5	304.5	0.13	2.8	2LC0131-0AC	103
		1500	55	120	55	120	320	180	192	125	236	4.5	630	350.5	350.5	0.22	7.9	2LC0131-0AC	156
320	5500	1500	55	120	55	120	320	180	192	125	236	4.5	630	350.5	350.5	0.22	7.9	2LC0131-1AC	170
		1300	65	130	65	130	360	200	210	140	265	4.5	710	394.5	394.5	0.4	13.9	2LC0131-1AC	215
360	7800	1500	65	130	65	130	360	200	210	140	236	4.5	630	380.5	380.5	0.4	8.1	2LC0131-2AC	189
		1300	65	130	65	130	360	200	210	140	265	4.5	710	409.5	409.5	0.4	14	2LC0131-2AC	234

Configurable variants ¹⁾

- ØD1 Without finished bore
With finished bore
- ØD2 Without finished bore
With finished bore

Note

- For dimensions U1 and P, see type RWN on Page 8/8.
- Weight and mass moments of inertia apply to maximum bore diameters.
- The article numbers apply to standard buffers of NBR material in the 80 ShoreA variant; the article number for alternative buffer types is available on request.

Ordering example

- RUPEX RWB coupling, size 252
- Part 1: Bore 48H7 mm, keyway to DIN 6885-1 and set screw
- Part 3: 500 x 190, bore 42H7 mm, keyway to DIN 6885-1 P9 and set screw.
- Coupling micro-balanced G 6.3 at 1500 rpm in accordance with half parallel key standard

Article no.: 2LC0130-8AC99-0FA0-Z L1B+M0X+W02+Y95
Plain text to Y95: G=6.3;n=1500rpm

¹⁾ To identify complete item numbers specifying the available finish boring options and – if necessary – further order options, please use our configurators on flender.com.

↗ For online configuration on flender.com, click on the item no.

TYPE RBS

with brake drum to DIN 15431

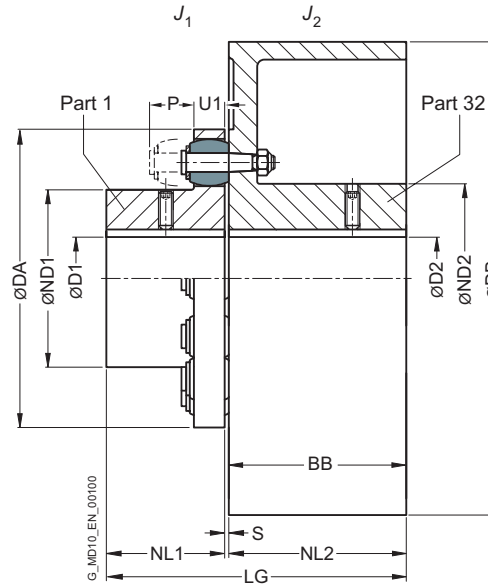

Size	Rated torque		Speed n_{Kmax} rpm	Dimensions in mm												Mass moment of inertia		Article no. ²⁾	Weight m kg
	buffer 90 ShoreA $T_{KN}^{1)}$ Nm	buffer 80 ShoreA T_{KN} Nm		Bore with keyway DIN 6885-1				DA	ND1	ND2	NL1	NL2/ BB	S	DB	LG	J_1 kgm ²	J_2 kgm ²		
				D1 min.	D1 max.	D2 min.	D2 max.												
144	650	500	7800	-	55	-	60	144	76	84	55	75	3	200	133	0.004	0.04	2LC0130-3AD	10
162	950	750	6900	-	60	-	65	162	85	92	60	95	3.5	250	158.5	0.007	0.13	2LC0130-4AD	18
178	1200	950	6300	-	75	-	75	178	102	108	70	95	3.5	250	168.5	0.014	0.13	2LC0130-5AD	22
			5500									118		315	191.5		0.34	2LC0130-5AD	30
198	1700	1300	5600	-	90	-	85	198	120	128	80	95	3.5	250	178.5	0.020	0.14	2LC0130-6AD	26
			5500									118		315	201.5		0.35	2LC0130-6AD	35
228	2850	2200	4300	-	95	-	95	228	129	140	90	150	3.5	400	243.5	0.036	1.1	2LC0130-7AD	60
252	3550	2750	4300	-	110	38	110	252	150	160	100	150	3.5	400	253.5	0.066	1.1	2LC0130-8AD	67
			3400				190					500		293.5	3.1		2LC0130-8AD	102	
285	5600	4300	3400	48	120	48	110	285	164	175	110	190	4.5	500	304.5	0.12	3.1	2LC0131-0AD	114
			2700				236					630		350.5	8.5		2LC0131-0AD	170	
320	7150	5500	2700	55	130	55	125	320	180	192	125	236	4.5	630	365.5	0.23	8.6	2LC0131-1AD	185
			2400				265					710		394.5	14.8		2LC0131-1AD	230	
360	10000	7800	2700	65	145	65	135	360	200	210	140	236	4.5	630	380.5	0.4	8.9	2LC0131-2AD	208
			2400				265					710		409.5	15.1		2LC0131-2AD	253	

Configurable variants ²⁾

- ØD1 Without finished bore
With finished bore
- ØD2 Without finished bore
With finished bore

Note

- For dimensions U1 and P, see type RWS on Page 8/10.
- Weight and mass moments of inertia apply to maximum bore diameters.
- The article numbers apply to standard buffers of NBR material in the 80 ShoreA variant; the article number for alternative buffer types is available on request.

¹⁾ T_{Kmax} is given in the specifications on Page 8/6.
 T_{KW} is determined from the specifications given on Page 8/6.

Ordering example

- RUPEX RBS coupling, size 252
- Part 1: Bore 48H7 mm, keyway to DIN 6885-1 and set screw
- Part 3: 500 x 190, bore 42H7 mm, keyway to DIN 6885-1 P9 and set screw
- Coupling micro-balanced G 6.3 at 1500 rpm in accordance with half parallel key standard

Article no.: 2LC0130-8AD99-0FA0-Z L1B+M0X+W02+Y95
Plain text to Y95: G=6.3;n=1500rpm

²⁾ To identify complete item numbers specifying the available finish boring options and – if necessary – further order options, please use our configurators on flender.com.

➤ For online configuration on flender.com, click on the item no.

SPARE AND WEAR PARTS

Buffers and pins

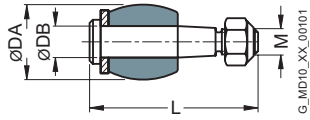

Sizes 105 to 400

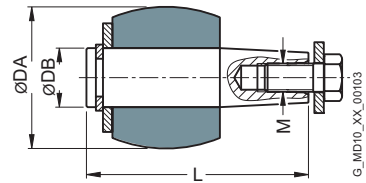

Sizes 710 to 2000

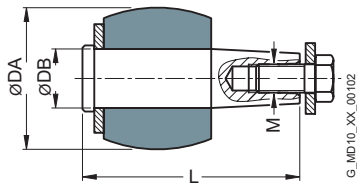

Sizes 450 to 630

Size	Marking	Number per set	Dimensions				Article No. for a set of buffers [Buffer Perbunan 80ShoreA]	Weight <i>m</i> kg	Article No. for a set of pins [Pin complete, incl. fasteners]	Weight <i>m</i> kg
			DA mm	DB mm	L mm	M				
105	105	8	20	8	45	M6	2LC0130-1WA00-0AA0	0.043	2LC0130-1WB00-0AA0	0.14
125	125	8	24	10	53.5	M8	2LC0130-2WA00-0AA0	0.098	2LC0130-2WB00-0AA0	0.28
144 ¹⁾	125	10	24	10	53.5 59.5	M8	2LC0130-3WA00-0AA0	0.12	2LC0130-3WB00-0AA0 ASE36074885	0.35 0.4
162 ¹⁾	162	9	30	12	64.5 67.5	M10	2LC0130-4WA00-0AA0	0.17	2LC0130-4WB00-0AA0 ASE36074964	0.57 0.6
178 ¹⁾	162	10	30	12	64.5 67.5	M10	2LC0130-5WA00-0AA0	0.19	2LC0130-5WB00-0AA0 ASE36075371	0.65 0.67
198 ¹⁾	162	12	30	12	64.5 67.5	M10	2LC0130-6WA00-0AA0	0.23	2LC0130-6WB00-0AA0 ASE36075396	0.76 0.8
228	228	11	40	16	79	M12	2LC0130-7WA00-0AA0	0.42	2LC0130-7WB00-0AA0	1.4
252	228	12	40	16	79	M12	2LC0130-8WA00-0AA0	0.45	2LC0130-8WB00-0AA0	1.5
285	285	11	48	20	98	M16	2LC0131-0WA00-0AA0	0.81	2LC0131-0WB00-0AA0	2.5
320	285	12	48	20	98	M16	2LC0131-1WA00-0AA0	0.88	2LC0131-1WB00-0AA0	2.8
360	360	10	64	25	123	M18	2LC0131-2WA00-0AA0	1.6	2LC0131-2WB00-0AA0	4.4
400	360	14	64	25	123	M18	2LC0131-3WA00-0AA0	2.2	2LC0131-3WB00-0AA0	6.1
450	450	12	78	32	123	M16	2LC0131-4WA00-0AA0	3.5	2LC0131-4WB00-0AA0	11
500	450	14	78	32	123	M16	2LC0131-5WA00-0AA0	4	2LC0131-5WB00-0AA0	13
560	560	12	101	42	158	M20	2LC0131-6WA00-0AA0	7.1	2LC0131-6WB00-0AA0	25
630	560	14	101	42	158	M20	2LC0131-7WA00-0AA0	8.3	2LC0131-7WB00-0AA0	29
710	710	14	120	50	185.5	M24	2LC0131-8WA00-0AA0	14	2LC0131-8WB00-0AA0	49
800	710	16	120	50	185.5	M24	2LC0132-0WA00-0AA0	16	2LC0132-0WB00-0AA0	56
900	900	16	136	55	207.5	M24	2LC0132-1WA00-0AA0	24	2LC0132-1WB00-0AA0	71
1000	900	18	136	55	207.5	M24	2LC0132-2WA00-0AA0	27	2LC0132-2WB00-0AA0	80
1120	1120	18	155	60	232.5	M30	2LC0132-3WA00-0AA0	41	2LC0132-3WB00-0AA0	110
1250	1120	20	155	60	232.5	M30	2LC0132-4WA00-0AA0	45	2LC0132-4WB00-0AA0	125
1400	1400	20	175	70	274	M30	2LC0132-5WA00-0AA0	65	2LC0132-5WB00-0AA0	185
1600	1400	24	175	70	274	M30	2LC0132-6WA00-0AA0	78	2LC0132-6WB00-0AA0	225
1800	1800	22	200	80	327	M36	2LC0132-7WA00-0AA0	115	2LC0132-7WB00-0AA0	320
2000	1800	26	200	80	327	M36	2LC0132-8WA00-0AA0	135	2LC0132-8WB00-0AA0	380

Note

- The buffers of RUPEX couplings are wear parts.
The service life depends on the operating conditions.

¹⁾ For types RWB/RBS with brake disk BB = 30 only



FLEXIBLE COUPLINGS N-BIPEX SERIES



General	9/3
Benefits	9/3
Application	9/4
Function	9/4
Design and configurations	9/5
Technical specifications	9/7
Assignment of N-BIPEX sizes to output PM of IEC standard motors	9/9
Type BWN	9/10
Type BWT – Variant A	9/11
Type BWT – Variant B	9/12
Type BWT – Variant AB	9/13
Type BNT	9/14
Spare and wear parts	9/15



GENERAL

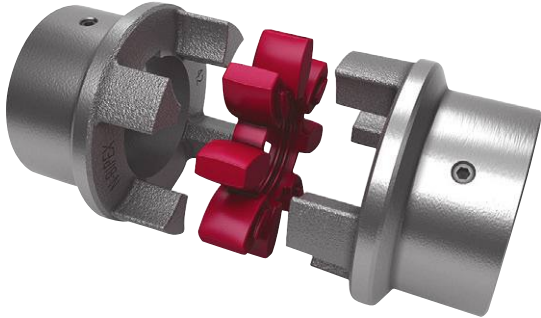

Coupling suitable for use in potentially explosive atmospheres.

Complies with the current ATEX Directive for:

CE  II 2G Ex h IIB T6 ... T4 Gb X

 II 2D Ex h IIIC T85 °C ... 120 °C Db X

 I M2 Ex h Mb X

N-BIPEX couplings are torsionally flexible and are outstanding for their particularly compact design and low weight.

N-BIPEX couplings are used in many areas of mechanical engineering.

Their main area of use is in electric motor drives which are well aligned and have uniform torque loads, such as in hydraulic applications and in combinations with geared motors.

Benefits

N-BIPEX couplings are suitable for horizontal, vertical and freely selectable mounting positions. They are able to absorb axial, radial and angular misalignment.

N-BIPEX couplings consist of two identical hub parts which can be arranged as required on the shaft extensions to be connected. N-BIPEX couplings transmit the torque positively and are thus fail-safe. The curved design of the cast cams ensures that the N-BIPEX couplings have a perfect pressure distribution and this increases the elastomer lifetime.

The flexible cam rings responsible for torque transmission and misalignment compensation are available in different Shore hardnesses. As a result of the good damping capability and by selecting the suitable stiffness, torque shock loads can thus be absorbed and the torsional vibration behavior of the drive can be positively influenced.

Different cam ring versions and ready-to-install hub parts are available from stock.

GENERAL

Application

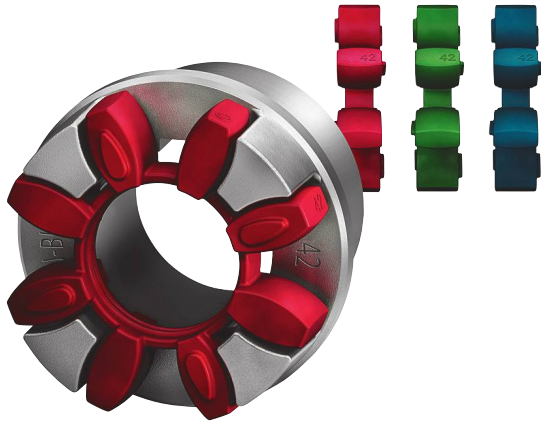

9

The N-BIPEX coupling is available as a catalog standard in 10 sizes with rated torques of between 12 Nm and 4650 Nm and is made of high-grade spheroidal graphite cast iron.

The extremely high-performance cam ring materials are available from stock in three different Shore hardnesses with the following colors:

- 92 ShoreA – red
- 95 ShoreA – green
- 64 ShoreD – blue

An additional size marking has been provided on the outer surface of the cam ring to be able to determine the size of the N-BIPEX even when it is in the assembled state without having to use any additional aids.

The coupling is suitable for use at ambient temperatures between -50 °C and +100 °C without any restrictions on the rated torque as a result of temperature factors.

Function

The torque is transmitted to the hub at the drive end via the shaft-hub connection, which is mostly designed as a keyway connection, and is transmitted to the hub on the output side via the cam ring. This hub then further transmits the torque to the driven machine or a gear unit placed in between.

The special cam ring design helps to keep the compression-loaded cam ring elements in their defined position under all operating conditions and to keep them evenly loaded. This results in a long lifetime of the flexible elements.

A long lifetime is also guaranteed by the hub parts which ensure maximum operational reliability even under harsh operating conditions.

Design and configurations

The N-BIPEX coupling of type BWN comprises two identical hub parts connected by a cam ring of elastomer material.

The hubs are connected to the respective shafts via finished bores with parallel keyway connection or Taper clamping bushes. N-BIPEX couplings are positive-locking and torsionally flexible thanks to the thermoplastic polyurethane cam ring.

Coupling materials

Hubs:

- Steel ¹⁾

Cam ring:

- TPU 92 ShoreA
-50 °C to +100 °C/120 °C without /with restrictions
- TPU 95 ShoreA
-50 °C to +100 °C/120 °C without /with restrictions
- TPU 64 ShoreD
-50 °C to +100 °C/120 °C without /with restrictions

The coupling comprises the following:

- Cam ring
- 2 hub parts with identical cams

The hub parts are designed with a bore and keyway to DIN 6885-1 or with a taper bore for mounting a Taper clamping bush.

Fitting the clamping bush connects the hub firmly to the machine shaft.

In the case of part 4 the Taper clamping bush is inserted from the machine housing side. If there is insufficient space, the Taper clamping bush cannot be fitted from this side. Besides space for fitting the Taper clamping bush, space for the fitting tool (offset screwdriver) must be taken into consideration. In the case of part 3, the Taper clamping bush is screwed in from the shaft end face side. The hub must be fitted before the machines to be connected are pushed together.

N-BIPEX coupling types

Type	Description
BWN	Coupling as a shaft-shaft connection with drilled and grooved hubs
BWT	Coupling as a shaft-shaft connection with Taper clamping bushes
BNT	Coupling as a shaft-shaft connection with drilled and grooved hubs and a Taper clamping bush

¹⁾ Size 19 hubs made of spheroidal graphite cast iron EN-GJS-400

Technical specifications

Cam rings									
Size	Rated torque	Maximum torque	Fatigue torque	Maximum speed	Damping coefficient Ψ	Torsional stiffness at 50 % capacity utilization	Permitted shaft misalignment at ¹⁾		
	T_{KN} Nm	T_{Kmax} Nm	T_{KW} Nm	$V \leq 45$ m/s n_{max} rpm			$C_{Tdyn 50\%}$ Nm/rad	< 10 Hz ΔK_a mm	n = 1500 rpm ΔK_r mm
Cam rings of polyurethane 92 ShoreA (standard)									
19	12	36	2	19500	1.4	530	0.3	0.17	0.5
24	45	135	7	14500	1.4	1790	0.4	0.23	0.5
28	95	285	14	12500	1.4	3060	0.5	0.25	0.5
38	190	570	29	10000	1.4	6500	0.6	0.29	0.5
42	265	795	40	8500	1.4	8200	0.7	0.34	0.5
48	330	990	50	7500	1.4	10000	0.8	0.38	0.5
55	460	1380	70	6500	1.4	14500	0.9	0.4	0.5
65	670	2010	100	6000	1.4	25600	1	0.45	0.5
75	1400	4200	210	5000	1.4	37400	1.2	0.52	0.5
90	2500	7500	375	4000	1.4	62700	1.4	0.6	0.5
Cam rings of polyurethane 95 ShoreA (ordering option -Z and order code K01)									
19	18	54	3	19500	1.4	1130	0.27	0.15	0.4
24	65	195	10	14500	1.4	4240	0.36	0.21	0.4
28	160	480	25	12500	1.4	8050	0.45	0.23	0.4
38	325	975	50	10000	1.4	14100	0.54	0.26	0.4
42	450	1350	70	8500	1.4	16200	0.63	0.31	0.4
48	550	1650	85	7500	1.4	23300	0.72	0.34	0.4
55	700	2100	105	6500	1.4	28500	0.81	0.36	0.4
65	1000	3000	150	6000	1.4	35000	0.9	0.41	0.4
75	2000	6000	300	5000	1.4	66300	1.08	0.47	0.4
90	3700	11100	555	4000	1.4	105000	1.26	0.54	0.4
Cam rings of polyurethane 64 ShoreD (ordering option -Z and order code K04)									
19	25	75	5	19500	1.4	2010	0.24	0.14	0.3
24	90	270	15	14500	1.4	7680	0.32	0.18	0.3
28	200	600	30	12500	1.4	12200	0.4	0.2	0.3
38	405	1215	60	10000	1.4	25100	0.48	0.23	0.3
42	560	1680	84	8500	1.4	32000	0.56	0.27	0.3
48	700	2100	105	7500	1.4	41200	0.64	0.3	0.3
55	925	2775	140	6500	1.4	52600	0.72	0.32	0.3
65	1200	3600	180	6000	1.4	86700	0.8	0.36	0.3
75	2600	7800	390	5000	1.4	143000	0.96	0.42	0.3
90	4650	13950	700	4000	1.4	234000	1.12	0.48	0.3

¹⁾ The maximum speed must be observed. For further information on the allowable shaft misalignment, please refer to the operating instructions.

GENERAL

Torsional stiffness and damping

The values stated in the above table apply to a capacity utilization of 50 %, an excitation amplitude of 10 % T_{KN} with frequency 10 Hz and an ambient temperature of 20 °C. The dynamic torsional stiffness (C_{Tdyn}) is load-dependent and increases in proportion to capacity utilization. The following table shows the correction factors for different nominal load.

$$C_{Tdyn} = C_{Tdyn} 50 \% \cdot FKC$$

	Load T_N / T_{KN}						
	20%	40%	50%	60%	70%	80%	100%
Correction factor FKC							
92/95 ShoreA and 64 ShoreD	0.56	0.85	1	1.17	1.35	1.53	1.92

Furthermore, torsional stiffness and damping depend on the ambient temperature, the frequency and the amplitude of the torsional vibration excitation. More precise torsional stiffness and damping parameters on request.

With flexible couplings the manufacturing process of the rubber elements and their aging primarily influence the stiffness value C_{Tdyn} . For this reason calculation must be made with a tolerance for the dynamic stiffness of $\pm 20\%$. The specified damping coefficient Ψ is a minimum value with the result that the damping performance of the coupling corresponds at least to the specified value.

Permitted shaft misalignment

The permitted shaft misalignment depends on the operating speed. As the speed increases, lower shaft misalignment values are permitted. The correction factors for different speeds are specified in the following table. The maximum speed depending on the respective coupling size and type must be observed!

$$\Delta K_{perm} = \Delta K_{1500} \cdot FKV$$

	Speed in rpm			
	500	1000	1500	3000
Correction factor FKV	1.20	1.10	1.00	0.70

The axial misalignment may occur dynamically at frequencies up to 10 Hz.

For fitting, the maximum gap dimension of $S2_{max.} = S2 + \Delta S2$ and the minimum gap dimension of $S2_{min.} = S2 - \Delta S2$ are permitted.

The shaft misalignments ΔK_a , ΔK_r and ΔK_w may occur simultaneously (see Page E/12).

Assignment of N-BIPEX sizes to output PM of IEC standard motors ¹⁾

Three-phase motor Size	Motor output at ≈ 3000 min ⁻¹		N-BIPEX coupling Size	Motor output at ≈ 1500 min ⁻¹		N-BIPEX coupling Size	Motor output at ≈ 1000 min ⁻¹		N-BIPEX coupling Size	Motor output at ≈ 750 min ⁻¹		N-BIPEX coupling Size	DE shaft end D x E acc. to IEC	
	P _M kW	T Nm		P _M kW	T Nm		P _M kW	T Nm		P _M kW	T Nm		D mm	E mm
80	0.75	2.5	19	0.55	3.7	19	0.37	3.9	19	0.18	2.5	19	19	40
	1.1	3.7	19	0.75	5.1	19	0.55	5.8	19	0.25	3.5	19		
90S	1.5	5	19	1.1	7.5	19	0.75	8	19	0.37	5.3	19	19	40
90L	2.2	7.4	19	1.5	10	24	1.1	12	24	0.55	7.9	24	19	40
													24	50
100L	3	9.8	24	2.2	15	24	1.5	15	24	0.75	11	24	28	60
				3	20	24				1.1	16	24		
112M	4	13	24	4	27	24	2.2	22	24	1.5	21	24	28	60
132S	5.5	18	28	5.5	36	28	3	30	28	2.2	30	28	38	80
	7.5	25	28											
132M				7.5	49	28	4	40	28	3	40	28	38	80
							5.5	55	28					
160M	11	36	38	11	72	38	7.5	75	38	4	54	38	42	110
	15	49	38							5.5	74	38		
160L	18.5	60	38	15	98	38	11	109	38	7.5	100	38	42	110
180M	22	71	38	18.5	121	38							48	110
180L				22	144	38	15	148	42	11	145	42	48	110
200L	30	97	42	30	196	42	18.5	181	42	15	198	42	55	110
	37	120	42				22	215	42					
225S				37	240	48				18.5	244	48	60	140
225M	45	145	42										55	110
				45	292	55	30	293	55	22	290	55	60	140
250M	55	177	48										60	140
				55	356	55	37	361	55	30	392	65	65	140
280S	75	241	55										65	140
				75	484	65	45	438	65	37	483	65	75	140
280M	90	289	55										65	140
				90	581	75	55	535	75	45	587	75	75	140
315S	110	353	55										65	140
				110	707	75	75	727	75	55	712	75	80	170
315M	132	423	65										65	140
				132	849	75	90	873	75	75	971	75	80	170
315L	160	513	65										65	140
	200	641	75											
				160	1030	75	110	1070	75	90	1170	90	80	170
				200	1290	90	132	1280	90	110	1420	90		
315	250	802	75										65	140
	315	1010	90											
355				250	1600	90	200	1930	90				85	170
	355	1140	90										75	140
	400	1280	90										75	140
400	500	1600	90										75	140
	560	1790	90										80	170

¹⁾ The assignment applies for an service factor of 1.25 and the use of a standard cam ring (92 ShoreA).

TYPE BWN

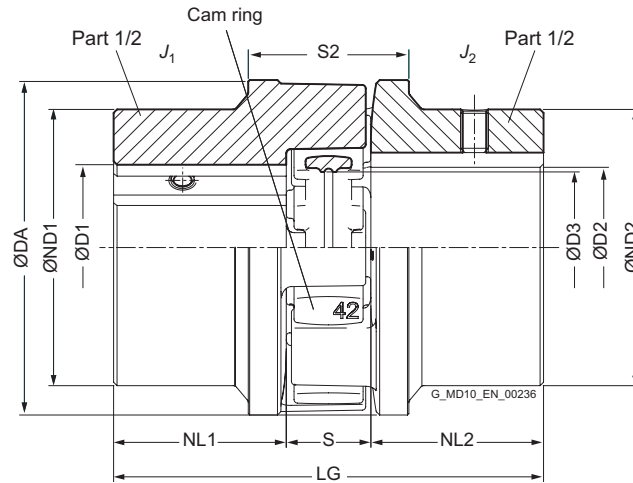

9

Size	Rated torque			Speed n_{Kmax} rpm	Dimensions in mm										Mass moment of inertia J_1/J_2 kgm ²	Article no. ¹⁾	Weight m kg
	T_{KN}		64ShoreD Nm		D1/D2 Keyway DIN 6885 min.	DA	ND1/ ND2	NL1/ NL2	D3	S	S2	$\Delta S2$	LG				
	92 ShoreA Nm	95 ShoreA Nm															
19	12	18	25	19500	0	25	42	38	25	17	16	31	1	66	0,000045	2LC0160-0AA	0,3
24	45	65	90	14500	0	35	55	55	30	25	18	-	1,5	78	0,0002	2LC0160-1AA	0,8
28	95	160	200	12500	0	40	65	65	35	28	20	-	1	90	0,0005	2LC0160-2AA	1,3
38	190	325	405	10000	0	48	80	70	45	36	24	60	1,5	114	0,001	2LC0160-3AA	2,0
42	265	450	560	8500	0	55	95	85	50	43	26	70	1,5	126	0,002	2LC0160-4AA	3,5
48	330	550	700	7500	0	62	105	95	56	48	28	76	2	140	0,004	2LC0160-5AA	4,7
55	460	700	925	6500	0	75	120	110	65	57	30	86	2	160	0,008	2LC0160-6AA	6,7
65	670	1000	1200	6000	0	82	135	115	75	64	35	91	2,5	185	0,013	2LC0160-7AA	8,8
75	1400	2000	2600	5000	0	96	160	135	85	76	40	104	2,5	210	0,027	2LC0160-8AA	13,8
90	2500	3700	4650	4000	0	120	200	160	100	95	45	121	3	245	0,071	2LC0161-0AA	23,3

Configurable variants ¹⁾

- ØD1 Without finished bore
With finished bore
- ØD2 Without finished bore
With finished bore
- Cam ring hardness **92 ShoreA**
95 ShoreA
64 ShoreD

Notes

- Mass moments of inertia apply to a coupling half with maximum bore diameter.
- Weights apply to a whole coupling in the version with maximum bore.

Ordering example

- N-BIPEX coupling BWN, size 42
- Part 1/2: Bore D1 42 H7 mm, with keyway to DIN 6885-1 and set screw
- Part 1/2: Bore D2 32 H7 mm, with keyway to DIN 6885-1 and set screw
- Cam ring hardness 92 ShoreA

Article no.: 2LC0160-4AA99-0AA0-Z L0X+M0T

¹⁾ To identify complete item numbers specifying the available finish boring options and – if necessary – further order options, please use our configurators on flender.com.

➤ For online configuration on flender.com, click on the item no.

TYPE BWT

Variant A

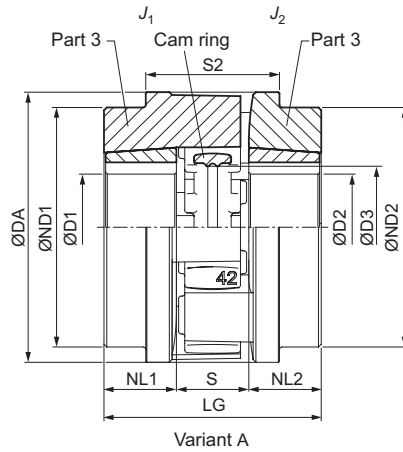

Size	Taper Clamping Bush Size	Rated torque		Speed n_{Kmax} rpm	Dimensions in mm										Mass moment of inertia J_1/J_2 kgm ²	Article no. ¹⁾ Type A	Weight m kg
		T_{KN}			D1/D2 Keyway DIN 6885	DA	ND1/ ND2	NL1/ NL2	D3	S	S2	$\Delta S2$	LG				
		92 ShoreA Nm	95 ShoreA Nm											min.			
24	1008	45	65	14500	10	25	55	55	23	25	18	-	1,5	64	0,00016	2LC0160-1AB	0,7
28	1108	95	160	12500	10	28	65	65	23	28	20	-	1	66	0,00033	2LC0160-2AB	1,0
38	1108	190	325	10000	10	28	80	58	23	36	24	45	1,5	70	0,0006	2LC0160-3AB	1,3
42	1610	265	450	8500	14	42	95	85	26	43	26	48	1,5	78	0,0013	2LC0160-4AB	2,0
48	1615	330	550	7500	14	42	105	80	39	48	28	50	2	106	0,002	2LC0160-5AB	2,9
55	2012	460	700	6500	14	50	120	100	33	57	30	60	2	96	0,004	2LC0160-6AB	3,8
65	2012	670	1000	6000	14	50	135	100	33	64	35	65	2,5	101	0,007	2LC0160-7AB	5
	2517 ²⁾				55	60		115	46					127	0,008		5,9
75	2517	1400	2000	5000	16	60	160	118	46	76	40	75	2,5	132	0,015	2LC0160-8AB	8,4
	3020 ²⁾				65	75		135	52					144	0,017		8,3
90	3020	2500	3700	4000	25	75	200	142	52	95	45	85	3	149	0,04	2LC0161-0AB	14,2
	3535 ²⁾				80	90		160	90					225	0,06		19,8

Configurable variants ¹⁾

- ØD1 Without Taper clamping bush
With Taper clamping bush
- ØD2 Without Taper clamping bush
With Taper clamping bush
- Cam ring hardness **92 ShoreA**
95 ShoreA

Notes

- Mass moments of inertia apply to a coupling half without Taper clamping bush.
- Weights apply to a whole coupling in the version without Taper clamping bush.
- T_{Kmax} for the 95 ShoreA cam ring is limited to $2 \times T_{KN}$ for types BWT and BNT contrary to the table on Page 9/7. When using the 64 ShoreD cam ring, the same torque values apply as for the 95 ShoreA cam ring.

Ordering example

- N-BIPEX BWT coupling, size 42, variant A
- Part 3: With Taper clamping bushes, size 1610, bore D1 38 H7 mm, with keyway to DIN 6885-1
- Part 4: With Taper clamping bushes, size 1610, bore D2 32 H7 mm, with keyway to DIN 6885-1
- Cam ring hardness 92 ShoreA

Article no.: 2LC0160-4AB99-0AA0-Z L0V+M0T

¹⁾ To identify complete item numbers specifying the available finish boring options and – if necessary – further order options, please use our configurators on flender.com.

²⁾ Taper clamping bush version only possible in part 4.

➤ For online configuration on flender.com, click on the item no.

TYPE BWT

Variant B

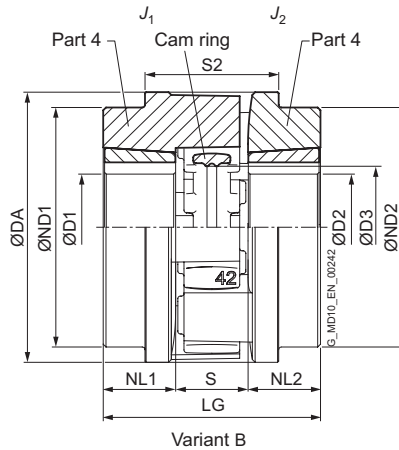

Size	Taper Clamping Bush Size	Rated torque		Speed n_{Kmax} rpm	Dimensions in mm										Mass moment of inertia J_1/J_2 kgm ²	Article no. ¹⁾ Type B	Weight m kg
		T_{KN}			D1/D2 Keyway DIN 6885	DA	ND1/ ND2	NL1/ NL2	D3	S	S2	$\Delta S2$	LG				
		92 ShoreA Nm	95 ShoreA Nm											min.			
24	1008	45	65	14500	10	25	55	55	23	25	18	-	1,5	64	0,00016	2LC0160-1AC	0,7
28	1108	95	160	12500	10	28	65	65	23	28	20	-	1	66	0,00033	2LC0160-2AC	1,0
38	1108	190	325	10000	10	28	80	58	23	36	24	45	1,5	70	0,0006	2LC0160-3AC	1,3
42	1610	265	450	8500	14	42	95	85	26	43	26	48	1,5	78	0,0013	2LC0160-4AC	2,1
48	1615	330	550	7500	14	42	105	80	39	48	28	50	2	106	0,002	2LC0160-5AC	2,9
55	2012	460	700	6500	14	50	120	100	33	57	30	60	2	96	0,004	2LC0160-6AC	3,8
65	2012	670	1000	6000	14	50	135	100	33	64	35	65	2,5	101	0,007	2LC0160-7AC	5
	2517 ²⁾				55	60								115	46		127
75	2517	1400	2000	5000	16	60	160	118	46	76	40	75	2,5	132	0,015	2LC0160-8AC	8,4
	3020 ²⁾				65	75								135	52		144
90	3020	2500	3700	4000	25	75	200	142	52	95	45	85	3	149	0,04	2LC0161-0AC	14,2
	3535 ²⁾				80	90								160	90		225

Configurable variants ¹⁾

- ØD1 Without Taper clamping bush
With Taper clamping bush
- ØD2 Without Taper clamping bush
With Taper clamping bush
- Cam ring hardness **92 ShoreA**
95 ShoreA

Notes

- Mass moments of inertia apply to a coupling half without Taper clamping bush.
- Weights apply to a whole coupling in the version without taper clamping bush.
- T_{Kmax} for the 95 ShoreA cam ring is limited to $2 \times T_{KN}$ for types BWT and BNT contrary to the table on Page 9/7. When using the 64 ShoreD cam ring, the same torque values apply as for the 95 ShoreA cam ring.

Ordering example

- N-BIPEX BWT coupling, size 42, variant B
- Part 3: With Taper clamping bushes, size 1610, bore D1 38 H7 mm, with keyway to DIN 6885-1
- Part 4: With Taper clamping bushes, size 1610, bore D2 32 H7 mm, with keyway to DIN 6885-1
- Cam ring hardness 92 ShoreA

Article no.: 2LC0160-4AC99-0AA0-Z L0V+M0T

¹⁾ To identify complete item numbers specifying the available finish boring options and – if necessary – further order options, please use our configurators on flender.com.

²⁾ Taper clamping bush version only possible in part 4.

➤ For online configuration on flender.com, click on the item no.

TYPE BWT

Variant AB

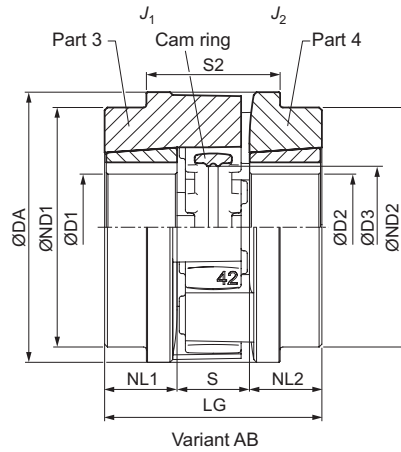

Size	Taper Clamping Bush Size	Rated torque		Speed n_{Kmax} rpm	Dimensions in mm										Mass moment of inertia J_1/J_2 kgm ²	Article no. ¹⁾	Weight m kg
		T_{KN}			D1/D2 Keyway DIN 6885	DA	ND1/ ND2	NL1/ NL2	D3	S	S2	ΔS2	LG				
		92 ShoreA Nm	95 ShoreA Nm											min.			
24	1008	45	65	14500	10	25	55	55	23	25	18	-	1,5	64	0,00016	2LC0160-1AD	0,7
28	1108	95	160	12500	10	28	65	65	23	28	20	-	1	66	0,00033	2LC0160-2AD	1,0
38	1108	190	325	10000	10	28	80	58	23	36	24	45	1,5	70	0,0006	2LC0160-3AD	1,3
42	1610	265	450	8500	14	42	95	85	26	43	26	48	1,5	78	0,0013	2LC0160-4AD	2,1
48	1615	330	550	7500	14	42	105	80	39	48	28	50	2	106	0,002	2LC0160-5AD	2,9
55	2012	460	700	6500	14	50	120	100	33	57	30	60	2	96	0,004	2LC0160-6AD	3,8
65	2012	670	1000	6000	14	50	135	100	33	64	35	65	2,5	101	0,007	2LC0160-7AD	5
	2517 ²⁾				55	60		115	46					127	0,008		5,9
75	2517	1400	2000	5000	16	60	160	118	46	76	40	75	2,5	132	0,015	2LC0160-8AD	8,4
	3020 ²⁾				65	75		135	52					144	0,017		8,3
90	3020	2500	3700	4000	25	75	200	142	52	95	45	85	3	149	0,04	2LC0161-0AD	14,2
	3535 ²⁾				80	90		160	90					225	0,06		19,8

Configurable variants ¹⁾

- ØD1 Without Taper clamping bush
With Taper clamping bush
- ØD2 Without Taper clamping bush
With Taper clamping bush
- Cam ring hardness **92 ShoreA**
95 ShoreA

Notes

- Mass moments of inertia apply to a coupling half without Taper clamping bush.
- Weights apply to a whole coupling in the version without taper clamping bush.
- T_{Kmax} for the 95 ShoreA cam ring is limited to $2 \times T_{KN}$ for types BWT and BNT contrary to the table on Page 9/7. When using the 64 ShoreD cam ring, the same torque values apply as for the 95 ShoreA cam ring.

Ordering example

- N-BIPEX BWT coupling, size 42, variant AB
- Part 3: With Taper clamping bushes, size 1610, bore D1 38 H7 mm, with keyway to DIN 6885-1
- Part 4: With Taper clamping bushes, size 1610, bore D2 32 H7 mm, with keyway to DIN 6885-1
- Cam ring hardness 92 ShoreA

Article no.: 2LC0160-4AD99-0AA0-Z L0V+M0T

¹⁾ To identify complete item numbers specifying the available finish boring options and – if necessary – further order options, please use our configurators on flender.com.

²⁾ Taper clamping bush version only possible in part 4.

➤ For online configuration on flender.com, click on the item no.

TYPE BNT

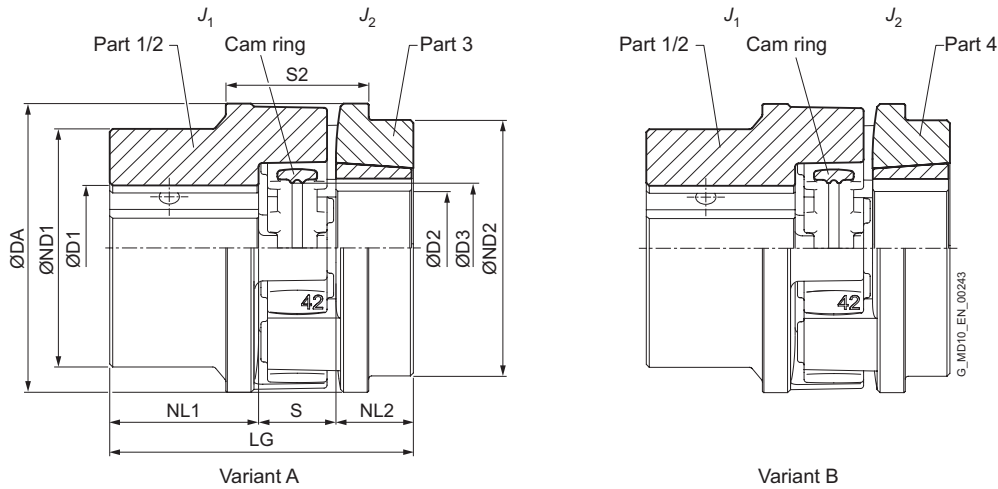

9

Size	Taper Clamping Bush Size	Rated torque		Speed n_{Kmax}	Dimensions in mm														Mass moment of inertia		Article no. ¹⁾		Weight m	
		T_{KN}			D1 Keyway DIN 6885	D2 Keyway DIN 6885		DA	ND1	ND2	NL1	NL2	D3	S	S2	$\Delta S2$	LG	J_1	J_2	Type	B			
		Nm	Nm			min.	max.													min.	max.	A		
24	1008	45	65	14500	0	35	10	25	55	55	55	30	23	25	18	-	1,5	71	0,0002	0,00016	2LC0160-1AE	2LC0160-1AF	0,7	-0AA0
28	1108	95	160	12500	0	40	10	28	65	65	65	35	23	28	20	-	1	78	0,0005	0,00033	2LC0160-2AE	2LC0160-2AF	1,1	-0AA0
38	1108	190	325	10000	0	48	10	28	80	70	58	45	23	36	24	52,5	1,5	92	0,001	0,0006	2LC0160-3AE	2LC0160-3AF	1,6	-0AA0
42	1610	265	450	8500	0	55	14	42	95	85	85	50	26	43	26	59	1,5	102	0,002	0,0013	2LC0160-4AE	2LC0160-4AF	2,8	-0AA0
48	1615	330	550	7500	0	62	14	42	105	95	80	56	39	48	28	63	2	123	0,004	0,002	2LC0160-5AE	2LC0160-5AF	3,8	-0AA0
55	2012	460	700	6500	0	75	14	50	120	110	100	65	33	57	30	73	2	128	0,008	0,004	2LC0160-6AE	2LC0160-6AF	5,3	-0AA0
65	2012 2517 ²⁾	670	1000	6000	0	82	14	50	135	115	100	75	33	64	35	78	2,5	143	0,013	0,007	2LC0160-7AE	2LC0160-7AF	6,9 7,4	-0AA0
75	2517 3020 ²⁾	1400	2000	5000	0	96	160	60	160	135	118	85	46	76	40	89,5	2,5	171	0,027	0,015	2LC0160-8AE	2LC0160-8AF	11,1 11	-0AA0
90	3020 3535 ²⁾	2500	3700	4000	0	120	25	75	200	160	142	100	52	95	45	103	3	197	0,065	0,04	2LC0161-0AE	2LC0161-0AF	18,8 21,6	-0AA0
																		235	0,071	0,06				

Configurable variants ¹⁾

• Type	A B
• ØD1	Without Taper clamping bush With Taper clamping bush
• ØD2	Without Taper clamping bush With Taper clamping bush
• Cam ring hardness	92 ShoreA 95 ShoreA

Ordering example

- N-BIPEX BNT coupling, size 42, variant B
 - Part 1/2: Bore D1 42 H7 mm, with keyway to DIN 6885-1 and set screw
 - Part 4: With Taper clamping bushes, size 1610, bore D2 32 H7 mm, with keyway to DIN 6885-1
 - Cam ring hardness 92 ShoreA
- Article no.: 2LC0160-4AF99-0AA0-Z LOX+M0T

Notes

- Mass moments of inertia apply to a coupling half with maximum bore diameter and without Taper clamping bush.
- Weights apply to a whole coupling in the version without taper clamping bush.
- T_{Kmax} for the 95 ShoreA cam ring is limited to $2 \times T_{KN}$ for types BWT and BNT contrary to the table on Page 9/7. When using the 64 ShoreD cam ring, the same torque values apply as for the 95 ShoreA cam ring.

¹⁾ To identify complete item numbers specifying the available finish boring options and – if necessary – further order options, please use our configurators on flender.com.
²⁾ Taper clamping bush version only possible in part 4.
³⁾ For online configuration on flender.com, click on the item no.

SPARE AND WEAR PARTS

Cam rings of the N-BIPEX coupling

Size	Article no. N-BIPEX cam ring			Weight kg
	92 ShoreA	95 ShoreA	64 ShoreD	
19	2LC0160-0WA00-0AA0	2LC0160-0WA00-0AA0-Z K01	2LC0160-0WA00-0AA0-Z K04	0.006
24	2LC0160-1WA00-0AA0	2LC0160-1WA00-0AA0-Z K01	2LC0160-1WA00-0AA0-Z K04	0.02
28	2LC0160-2WA00-0AA0	2LC0160-2WA00-0AA0-Z K01	2LC0160-2WA00-0AA0-Z K04	0.03
38	2LC0160-3WA00-0AA0	2LC0160-3WA00-0AA0-Z K01	2LC0160-3WA00-0AA0-Z K04	0.04
42	2LC0160-4WA00-0AA0	2LC0160-4WA00-0AA0-Z K01	2LC0160-4WA00-0AA0-Z K04	0.07
48	2LC0160-5WA00-0AA0	2LC0160-5WA00-0AA0-Z K01	2LC0160-5WA00-0AA0-Z K04	0.09
55	2LC0160-6WA00-0AA0	2LC0160-6WA00-0AA0-Z K01	2LC0160-6WA00-0AA0-Z K04	0.1
65	2LC0160-7WA00-0AA0	2LC0160-7WA00-0AA0-Z K01	2LC0160-7WA00-0AA0-Z K04	0.2
75	2LC0160-8WA00-0AA0	2LC0160-8WA00-0AA0-Z K01	2LC0160-8WA00-0AA0-Z K04	0.4
90	2LC0161-0WA00-0AA0	2LC0161-0WA00-0AA0-Z K01	2LC0161-0WA00-0AA0-Z K04	0.6

Note

- The cam rings of the N-BIPEX coupling are wear parts. The service life depends on the operating conditions.

APPENDIX

Fits	A/2
Fitting recommendations	A/2
Deviation table to DIN ISO 286	A/2
Cylindrical shaft ends, extract from DIN 748 Part 1 (long)	A/3
Central holes according to DIN 332 Part 2	A/3
Parallel key connections to DIN 6885-1	A/4
Related catalogs	A/6
Suitable gear solutions	A/8
The perfect coupling	A/10
Individual solutions	A/12
Flender Services	A/16

FITS

Fitting recommendations

For many applications, the fit assignment m6/H7 is especially suitable.

Description	Application	Shaft tolerance	Bore tolerance
Facile sliding fit	For steel or aluminum hubs Preferred for SIPEX and BIPEX-S coupling series	g6	H7
		h7	H7
		k6	F7
		m6	F7
Sliding fit with parallel key connection not suitable for reversing operation	For steel and cast hubs	j6	H7
		h6	J7
Press fit with parallel key connection not suitable for reversing operation	For steel and cast hubs	h6	K7
		k6	H7
Interference fit with parallel key connection suitable for reversing operation	For steel and cast hubs Only for steel hubs Preferred for ZAPEX and ARPEX coupling series	m6	H7
		n6	H7
		h6	M7
		h6	P7
		k6	M7
		m6	K7
		n6	J7
		p6	H7
Shrink fit connection without parallel key	Only for steel hubs The permitted hub tension must be urgently checked.	s6	F7
		u6	H6
		v6	H6
		x6	H6

Deviation table to DIN ISO 286 for above-mentioned fits for bore diameters from 10 mm to 250 mm

Bore diameter above	up to	Deviations in µm Bore						Shaft					
		F7	H7	J7	K7	M7	P7	h6	j6	k6	m6	n6	p6
10	18	+34	+18	+10	+6	0	-11	0	+8	+12	+18	+23	+29
		+16	0	-8	-12	-18	-29	-11	-3	+1	+7	+12	+18
18	30	+41	+21	+12	+6	0	-14	0	+9	+15	+21	+28	+35
		+20	0	-9	-15	-21	-35	-13	-4	+2	+8	+15	+22
30	50	+50	+25	+14	+7	0	-17	0	+11	+18	+25	+33	+42
		+25	0	-11	-18	-25	-42	-16	-5	+2	+9	+17	+26
50	80	+60	+30	+18	+9	0	-21	0	+12	+21	+30	+39	+51
		+30	0	-12	-21	-30	-51	-19	-7	+2	+11	+20	+32
80	120	+71	+35	+22	+10	0	-24	0	+13	+25	+35	+45	+59
		+36	0	-13	-25	-35	-59	-22	-9	+3	+13	+23	+37
120	180	+83	+40	+26	+12	0	-28	0	+14	+28	+40	+52	+68
		+43	0	-14	-28	-40	-68	-25	-11	+3	+15	+27	+43
180	250	+96	+46	+30	+13	0	-33	0	+16	+33	+46	+60	+79
		+50	0	-16	-33	-46	-79	-29	-13	+4	+17	+31	+50

A

Cylindrical shaft ends, extract from DIN 748 Part 1 (long)

	Diameter in mm																					
	24	25	28	30	32	35	38	40	42	45	48	50	55	60	65	70	75	80	85	90	95	100
ISO tolerance zone	k6												m6									
End length in mm	50	60	80					110						140				170				210

Central holes according to DIN 332 Part 2

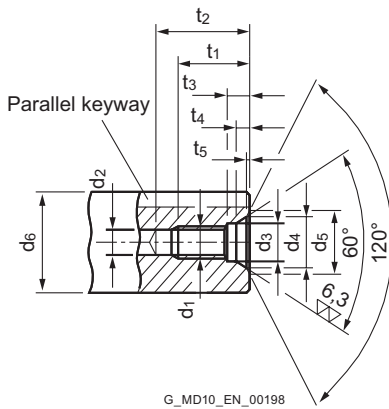

Form DS (with thread) DIN 332/2

Recommended diameter ranges d_6 ¹⁾		DS form dimensions										
above	up to	d_1	d_2 ²⁾	d_3	d_4	d_5	t_1 ₊₂	t_2 _{min.}	t_3 ₊₁	t_4 _{approx.}	t_5 _{approx.}	
7	10	M3	2.5	3.2	5.3	5.8	9	12	2.6	1.8	0.2	
10	13	M4	3.3	4.3	6.7	7.4	10	14	3.2	2.1	0.3	
13	16	M5	4.2	5.3	8.1	8.8	12.5	17	4	2.4	0.3	
16	21	M6	5	6.4	9.6	10.5	16	21	5	2.8	0.4	
21	24	M8	6.8	8.4	12.2	13.2	19	25	6	3.3	0.4	
24	30	M10	8.5	10.5	14.9	16.3	22	30	7.5	3.8	0.6	
30	38	M12	10.2	13	18.1	19.8	28	37	9.5	4.4	0.7	
38	50	M16	14	17	23	25.3	36	45	12	5.2	1.0	
50	85	M20	17.5	21	28.4	31.3	42	53	15	6.4	1.3	
85	130	M24	21	25	34.2	38	50	63	18	8	1.6	
130	225	M30 ³⁾	26.5	31	40.2	44.6	60	77	22	8	1.9	
225	320	M36 ³⁾	32	37	49.7	55	74	93	22	11	2.3	
320	500	M42 ³⁾	37.5	43	60.3	66.6	84	105	26	15	2.7	

¹⁾ Diameter refers to the finished workpiece

²⁾ Tap hole drill diameter according to DIN 336 Part 1

³⁾ Dimensions not acc. to DIN 332 Part 2

PARALLEL KEY CONNECTIONS TO DIN 6885-1

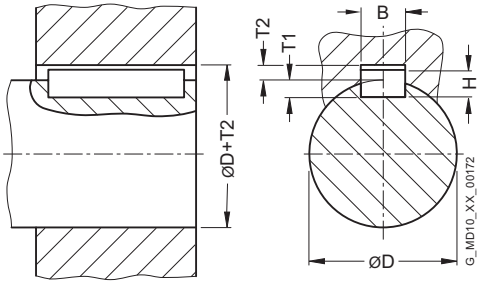

For moderate operating conditions, the hub keyway tolerance JS9 is recommended.

In harsh operating conditions or during reversing operation, the keyway width tolerance P9 must be preferred.

With two parallel keyways, the keyway width tolerance JS9 should be specified in order to simplify the assembly.

The shaft keyway width has to be specified with the tolerance N9.

Diameter above D mm	up to mm	Keyway width B mm	Parallel key height H mm	Shaft keyway depth T1 mm	Hub keyway depth T2 mm	Deviation for shaft and hub keyway depth mm	Deviation table for keyway width B	
							JS9 µm	P9 µm
	10	3	3	1.8	1.4	+0.1	+12.5 -12.5	-6 -31
10	12	4	4	2.5	1.8	+0.1	+15 -15	-12 -42
12	17	5	5	3	2.3	+0.1	+15 -15	-12 -42
17	22	6	6	3.5	2.8	+0.1	+15 -15	-12 -42
22	30	8	7	4	3.3	+0.2	+18 -18	-15 -51
30	38	10	8	5	3.3	+0.2	+18 -18	-15 -51
38	44	12	8	5	3.3	+0.2	+21.5 -21.5	-18 -61
44	50	14	9	5.5	3.8	+0.2	+21.5 -21.5	-18 -61
50	58	16	10	6	4.3	+0.2	+21.5 -21.5	-18 -61
58	65	18	11	7	4.4	+0.2	+21.5 -21.5	-18 -61
65	75	20	12	7.5	4.9	+0.2	+26 -26	-22 -74
75	85	22	14	9	5.4	+0.2	+26 -26	-22 -74
85	95	25	14	9	5.4	+0.2	+26 -26	-22 -74

Diameter		Keyway width B mm	Parallel key height H mm	Shaft keyway depth		Hub keyway depth T2 mm	Deviation for shaft and hub keyway depth mm	Deviation table for keyway width B	
above D mm	up to mm			T1 mm	T2 mm			JS9 µm	P9 µm
95	110	28	16	10	6.4	+0.2	+26 -26	-22 -74	
110	130	32	18	11	7.4	+0.2	+31 -31	-26 -88	
130	150	36	20	12	8.4	+0.3	+31 -31	-26 -88	
150	170	40	22	13	9.4	+0.3	+31 -31	-26 -88	
170	200	45	25	15	10.4	+0.3	+31 -31	-26 -88	
200	230	50	28	17	11.4	+0.3	+31 -31	-26 -88	
230	260	56	32	20	12.4	+0.3	+37 -37	-32 -106	
260	290	63	32	20	12.4	+0.3	+37 -37	-32 -106	
290	330	70	36	22	14.4	+0.3	+37 -37	-32 -106	
330	380	80	40	25	15.4	+0.3	+37 -37	-32 -106	
380	440	90	45	28	17.4	+0.3	+43.5 -43.5	-37 -124	
440	500	100	50	31	19.4	+0.3	+43.5 -43.5	-37 -124	

A

RELATED CATALOGS

Torsionally Rigid Couplings

FLE 10.1
FLEX-C10001-00-7600



Flexible Couplings

FLE 10.2
FLEX-C10002-00-7600



Highly Flexible Couplings

FLE 10.3
FLEX-C10003-00-7600



Fluid Couplings

FLE 10.4
FLEX-C10004-00-7600



ARPEX

High Performance Couplings
FLE 10.5
FLEX-C10120-00-7600



SIPEX und BIPEX-S

Backlash-free couplings
FLE 10.6
FLEX-C10121-00-7600



ARPEX

Safety couplings
FLE 10.7
FLEX-C10122-00-7600



FASTEX

Clamping elements
FLE 10.8
FLEX-C10152-00-7600



FLENDER SIP

Standard Industrial Planetary Gear Units

MD 31.1

PDMD-C10154-00



FLENDER CHG

Helical Gear Units

MD 20.10

PDMD-C10155-00



Gear units

Fast Track

MD 20.12

PDMD-C10156-00



Bucket Elevator Drives

MD 20.2

PDMD-C10157-00



PLANUREX 3

Planetary Gear Units

FLE 20.3

FLEX-C10052-00-7600



Paper Machine Drives

MD 20.5

PDMD-C10159-00



Conveyor Belt Drives

MD 20.6

PDMD-C10160-00



Marine Reduction Gearboxes

MD 20.7

PDMD-C10161-00



DUORED 2

Helical Gear Units, Load-sharing

MD 20.8

PDMD-C10162-00



Pinion Drive for Tube Mills

MD 20.9

PDMD-C10163-00





THE RIGHT GEAR UNIT SOLUTION FOR ANY REQUIREMENT

We provide helical and planetary gear units made up of standard modules or as a complete application solution.

Helical and planetary gear units from Flender are modern drive solutions that satisfy the most varying and extreme demands, day after day and year after year. For decades, plant operators have been achieving high system reliability and low lifecycle costs in every conceivable industry with our helical gear units.



Helical and bevel helical gear units

Flender helical and bevel helical gear units are by far the most comprehensive range of industrial gear units in the world. It ranges from a multi-faceted universal gear unit portfolio and application-specific gear units to customer-specific solutions.

Rated torque: 3,300 Nm ... 1,400,000 Nm



Planetary Gear Units

With Flender planetary gear units, we provide a range of durable, reliable and finely graduated gear unit solutions. The series wins customers over due to its highly integrated planetary geared motor and maximum conformity with all international motor standards. It also brings quality and performance in a good ratio of lifecycle costs to price.

Rated torque: 10,000 Nm ... 5,450,000 Nm

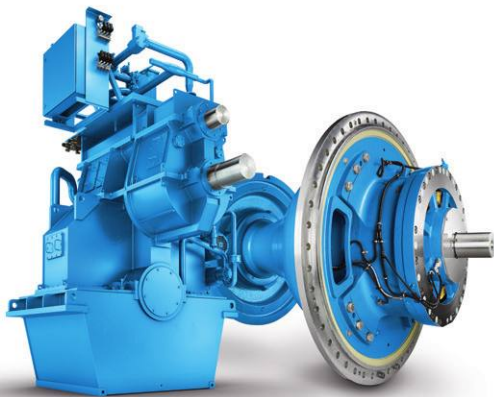

Application-specific gear units

With application-specific gear units, Flender provides by far the most application solutions and thus covers nearly every drive-related need from hundreds of applications in industry and the acquisition of raw materials.

Rated torque: up to 10,000,000 Nm



Customer-specific designs

Our experts are available at any time for special requirements during the development of new products. From designing and simulating complex drive solutions to implementing them, we work together with you to resolve multi-layered tasks.

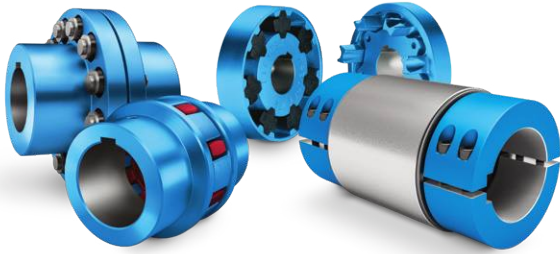

Flexible couplings

Our elastic couplings are pluggable and easy to install. The elastomer element equalizes the shaft offset and absorbs impacts from the motor or driven machine.

Nominal output torque: 12 Nm ... 1,690,000 Nm



Torsionally rigid couplings

Our compact steel couplings provide extremely precise transmission of high torques, especially in harsh operating conditions and extreme temperatures.

Nominal output torque: 92 Nm ... 7,200,000 Nm



Hydrodynamic couplings

Soft start, overload protection, torsional vibration damping – FLUDEX® fluid couplings allow the torque-limited approach and have very little slippage at rated load.

Power: 1.2 kW ... 2,500 kW



Highly-flexible couplings

Highly flexible couplings are well-suited for connecting machines that operate asymmetrically. They are preferred for use in systems that are periodically operated.

Nominal output torque: 24 Nm ... 90,000 Nm



Application-specific couplings

Flender offers a variety of application-specific couplings for rail vehicles and use in wind energy generation.



Backlash-free couplings

Our couplings act as a modular interface between the motor and the work machine to ensure reliable, backlash-free power transmission in servodrives and positioning drives.

Nominal output torque: 0.1 Nm ... 5,000 Nm

Flender's system competence turns first-class components into systems with tangible added value. Drive systems from Flender ensure maximum productivity, energy efficiency and reliability in any automation environment.

Consultation

Our customers use our interdisciplinary know-how, our application competence, our innovation strength and, last but not least, our experience to find the right drive system for their individual requirements.

Reduced engineering time, lower costs



Integrated drive portfolio

We not only provide gear units and couplings, but also have the competence in electrical drive technology that enables us to offer the entire drive train – perfectly integrated, with optimal interaction between all components, as a standard or individual solution.

Fewer interface risks, more efficiency

INDIVIDUAL SOLUTIONS.

We have the right solution for you, even if your requirements are special. We no longer have to newly develop every special solution. Many solutions are already available.

At [flender.com](https://www.flender.com), we provide application-specific solutions for your special requirements.

Use our online configurator, which allows you to create tailored product combinations.

Flender service

From diagnostics and support, replacement part and repair services, all the way to maintenance and retrofit services – the Flender service portfolio creates individual solutions, fully and completely tailored to the needs of our customers. In this way, a gear unit remains an original Flender gear unit.

Increased system availability, reduced lifecycle costs

DIAGNOSTEX

Ensuring the process stability requires status-oriented maintenance of the drive train. With DIAGNOSTEX®, sensors measure deviations of our gear units from the target status. These can be analyzed and evaluated in terms of maximized system availability.

Industrie 4.0, reduced costs

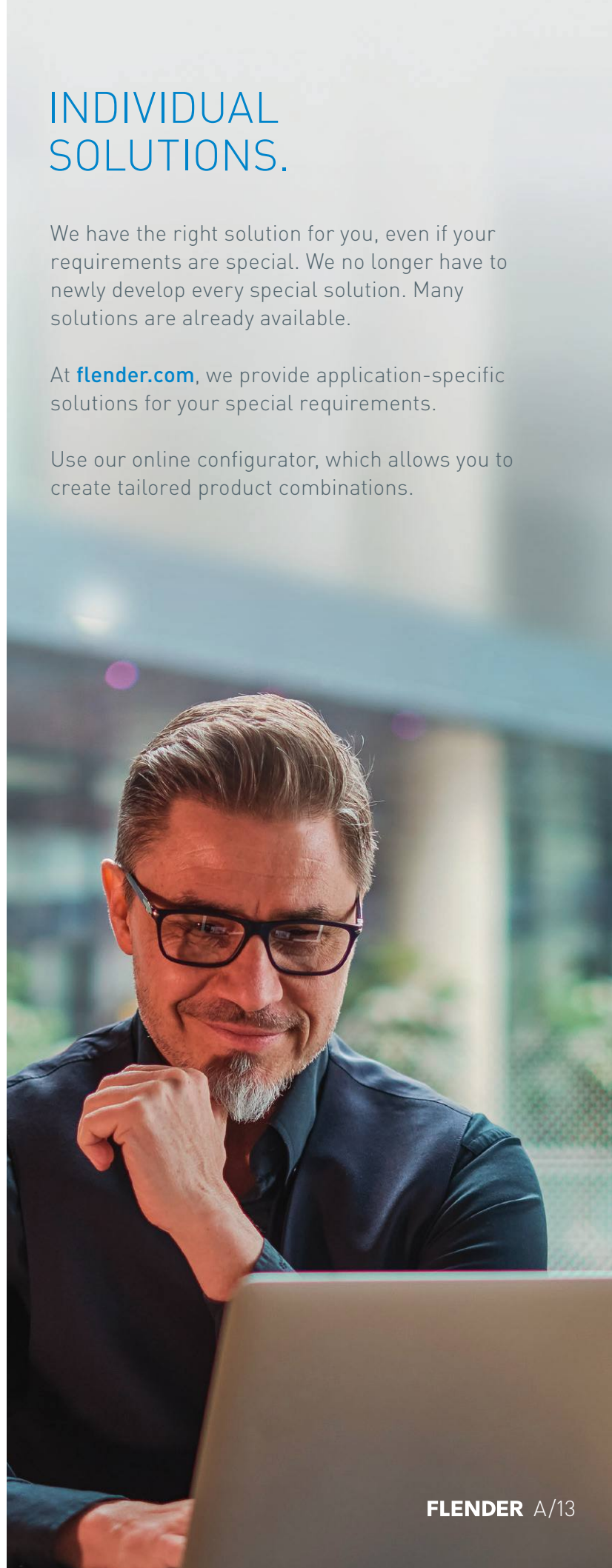

GREAT EXPERTISE IN YOUR INDUSTRY TOO.

Each industry has its own conditions. Every application has its own specific requirements. We are looking forward to meeting your challenges.

We probably already have the right solution at hand. Here are a few examples:



Minerals and mining

Requirement:
Perfectly coordinated drive system



Cement

Requirement:
Low maintenance effort and cost,
sealing due to dirt in surroundings



Plastics and rubber

Requirement:
Absorption of high axial forces,
suitability for explosion protection



Environmental and recycling

Requirement:
Highest possible reliability, rugged
design



Pulp and paper

Requirement:
Suitability for centrally located
lubrication



Industrial cranes

Requirement:
Quick availability, version with
double drive shaft



Chemicals

Requirement:
Absorption of forces from the manufacturing process



Power generation

Requirement:
Effective cooling, speed adjustment for motor to fan



Metals

Requirement:
Harsh working conditions, high peak loads



Harbor cranes

Requirement:
Specific axle clearance, frequent start-up



Oil and gas

Requirement:
Flexible adaptation to speed requirements



Water and wastewater

Requirement:
Absorption of external forces, oil-retaining pipe required



AN ORIGINAL FOR THE LONG TERM WITH ORIGINAL FLENDER SERVICES

Ever increasing requirements make it more and more important for industrial plants to work with maximum productivity and efficiency. Flender Services give companies a decisive advantage over the competition in industry, the acquisition of raw materials and energy production. In view of the high cost pressure, increasing energy prices and stricter and stricter environmental stipulations, our services are becoming a decisive factor to success over the competition.

Enjoy the support of our service experts, from planning, development and operation to the modernization of your plant and benefit from our experience and in-depth know-how of your application – in more than 100 countries, seven days a week, 24 hours a day.

Reduce standstills, minimize downtimes due to failure, and increase the productivity, flexibility and cost efficiency of your plant.

OUR OFFER FOR GEAR UNITS AND COUPLINGS AT A GLANCE.

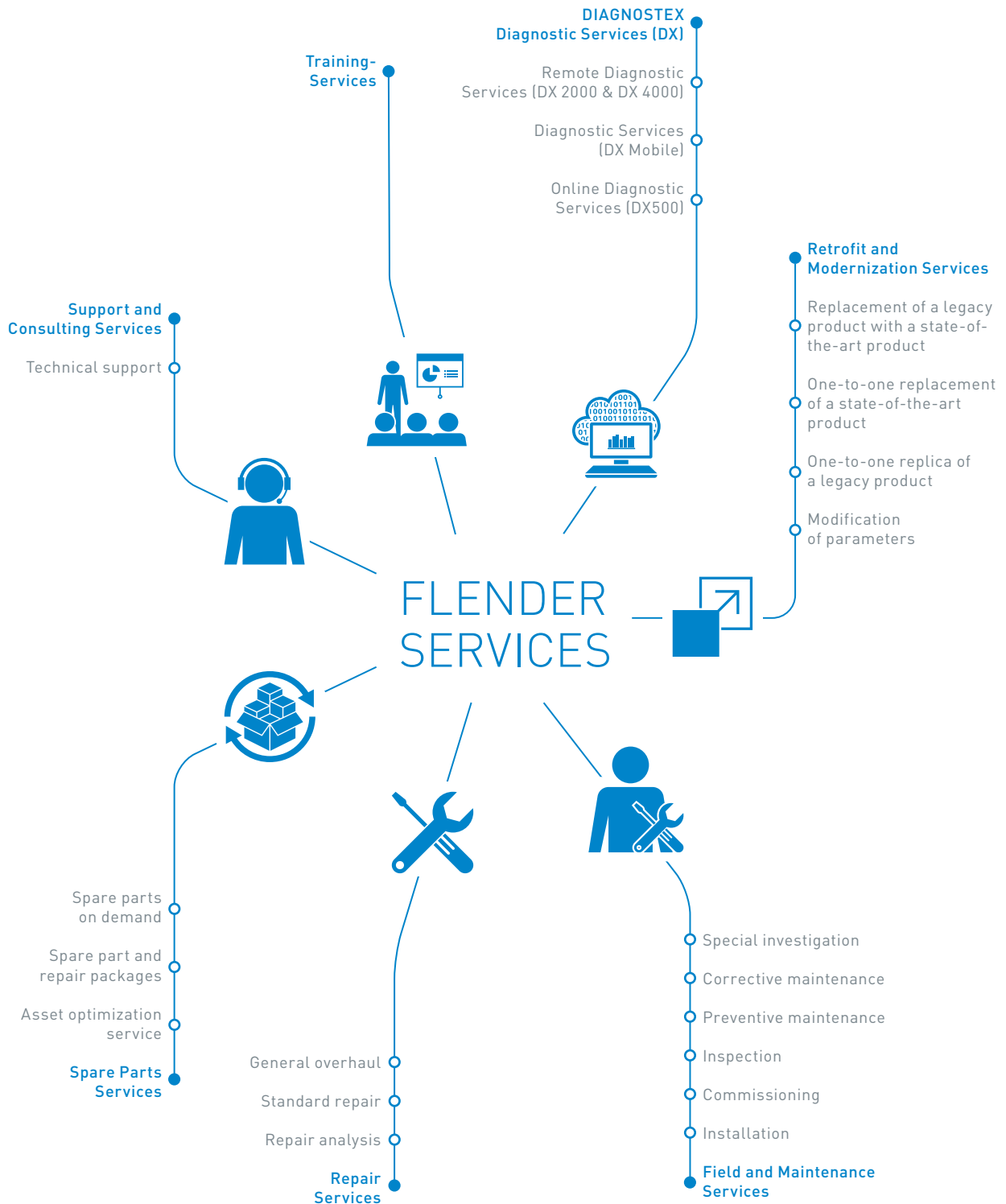

FLENDER COUPLINGS CATALOG **FLE 10.2** EDITION 2024 EN



WE
MOVE_{the}
WORLD

Flender GmbH

Alfred-Flender-Straße 77
46395 Bocholt
Germany

Article no.: FLEX-C10002-00-7600

Subject to changes and errors.

The information given in this product catalog includes descriptions and performance features that in specific applications do not always apply in the form described or may change through further-development of the products. The desired performance features are binding only if they are expressly agreed on conclusion of contract. Subject to availability for delivery and to technical changes.