

# POWER SMART SAVE BIG

---

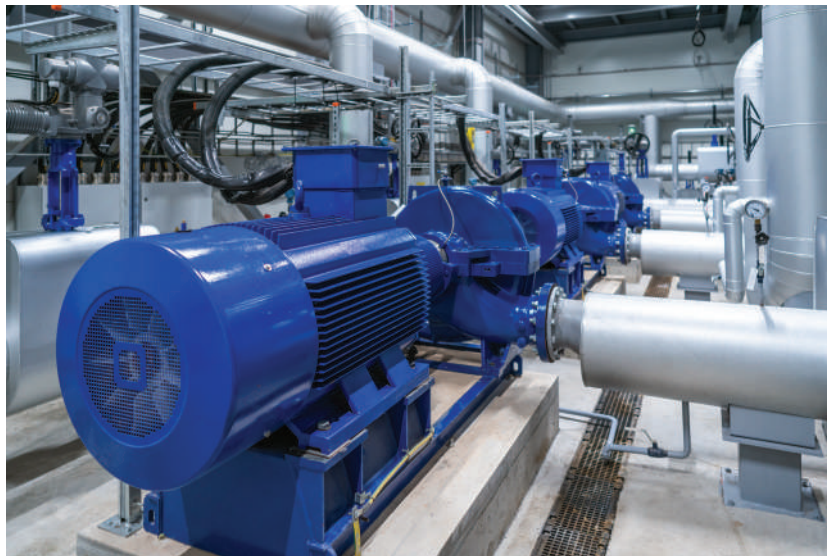

MINIMIZE MOTOR CABLE LOSSES  
WITH CBC SMART CAPACITORS

OPTIMIZE YOUR MOTOR SYSTEMS, REDUCE ENERGY WASTE, AND SLASH OPERATING COSTS



## The Hidden Cost of Inefficient Motor Cable Runs



- Energy loss in long cables between MDBs and motors or LDBs.
- The root cause: resistance in cables, especially over long distances, that results in heat generation and wasted energy.
- Increased electricity bills, reduced equipment efficiency, potential for overheating, and higher operating costs.



## Challenges

- System stability, improved power quality, and reduced electrical loss.
- Reduced energy bills, reduced operating costs, and extended equipment life, improved compliance.
- Reduced downtime, increased production uptime, and improved operational reliability.

## Solutions

- CBC Smart Capacitors as the solution to reduce cable losses.
- The intelligent capacitor is strategically placed near the motor or LDB to address power factor right at the source and minimize reactive power in cables.

## Key Features

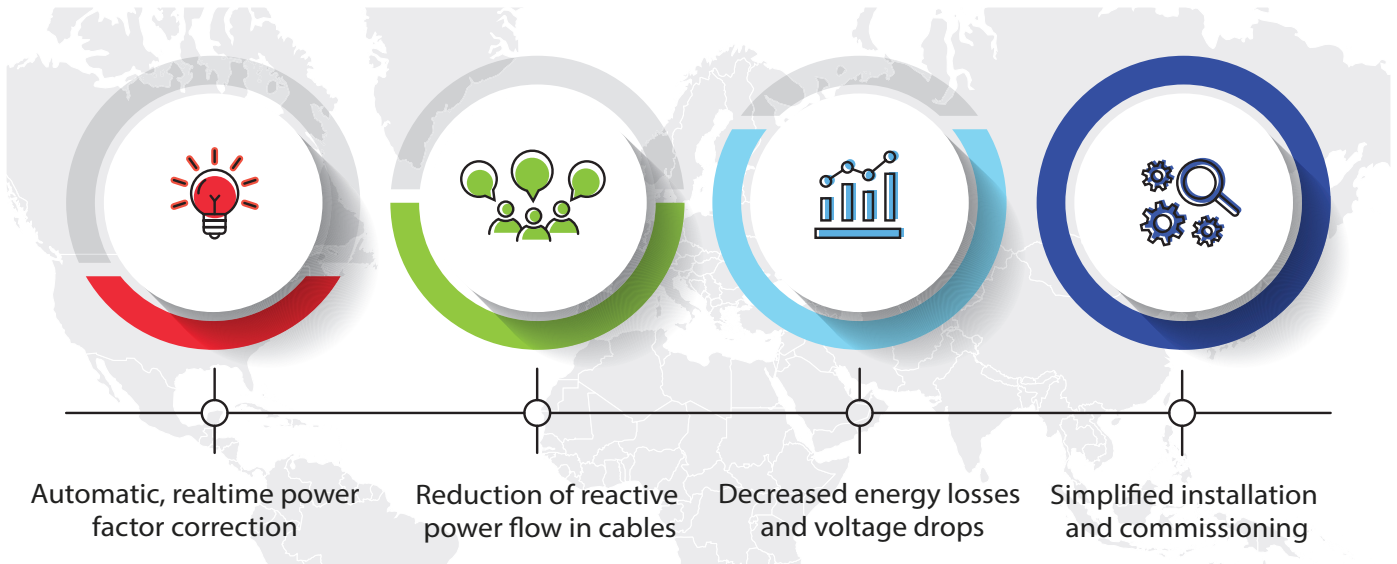

## Benefits

### Lower Costs

Energy efficiency directly cuts operating expenses by reducing energy consumption, freeing up capital for other business needs and boosting competitiveness.

### Investment Funds

It is a process to allow an organization to focus resources on the greatest opportunities to increase sales and achieve the company's target.



## Data Driven Results

### Benefits of placing smart capacitors at motor level

Motor Power (kW)	P.F. at 60% load	kVA at 60% load	kVAR design	Cable (mm <sup>2</sup> )	Cable (m)	Cost saving per year	Cable (m)	Cost saving per year	Cable (m)	Cost saving per year	Cable (m)	Cost saving per year	Cable (m)	Cost saving per year
11	0.70	7.9	7.5	1.5	100	12,543	150	18,814	200	25,085	250	31,356	300	37,628
15	0.71	10.6	10.2	2.5	100	13,642	150	20,462	200	27,283	250	34,104	300	40,925
18.5	0.72	12.8	12.5	4	100	12,328	150	18,492	200	24,655	250	30,819	300	36,983
22	0.73	15.1	14.7	6	100	11,120	150	16,680	200	22,241	250	27,801	300	33,361
30	0.75	20.0	19.6	10	100	11,190	150	16,785	200	22,380	250	27,975	300	33,571
37	0.76	24.3	24.0	16	100	10,204	150	15,305	200	20,407	250	25,509	300	30,611
45	0.78	28.8	28.5	25	100	8,672	150	13,008	200	17,344	250	21,680	300	26,016
55	0.79	34.8	34.4	25	100	12,342	150	18,512	200	24,683	250	30,854	300	37,025

Note\* cost saving in Baht with operating in 24hr/51 weeks

## Solutions

### Reduced Current Flow

By locally correcting the power factor, smart capacitors reduce the amount of current required to deliver the same amount of power to the loads. This directly minimizes the energy lost as heat in the long cable runs.

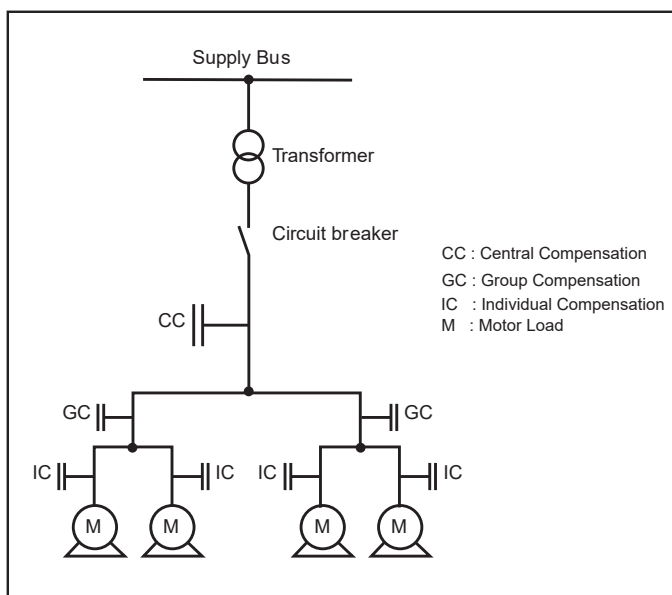
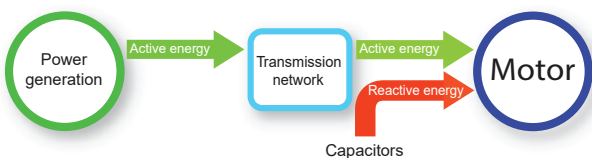

### Improved Voltage Stability

By reducing the current flowing through the cables, smart capacitors also help improve voltage stability at the load end, ensuring more consistent and reliable operation of equipment.

### Targeted Correction

Smart capacitors can dynamically adjust their capacitance based on the real-time demand of the load. This ensures optimal power factor correction at all times, unlike fixed capacitor banks which can become less effective as



## Investment

Smart capacitors of appropriate kVAR ratings were selected and installed at the load side or motor side

### Smart Capacitors

Smart Cap. Model	Reactive Power(kVAR) at480V/400V	Price List (Baht)
CBC-8CS/480-30 (15+15)	30 / 20.8	12,000-
CBC-8CS/480-20 (10+10)	20 / 13.9	10,700-
CBC-8CS/480-10 (5+5)	10 / 6.9	9,300-
CBC-8CS/480-5 (2.5+2.5)	5 / 3.5	8,600-

\*Note: Life time 5-7 years

### Cost saving for cable length 200 m

Motor (kW)	Power Saving(W)	Annual Savings (Baht)
11	903.5	25,085-
15	982.6	27,283-
18.5	888.0	24,655-
22	801.0	22,241-
30	806.0	22,380-
37	735.0	25,085-
45	624.7	17,344-
55	889.0	24,683-



## Return On Investment

Power Smart, Save Big

### Total Investment Cost

The total investment cost represents the sum of all expenses associated with purchasing and installing the smart capacitors. This includes the cost of the equipment itself, as well as labor, wiring, and other installation-related expenses.

Based on the investment table in the report, the total investment cost for an 18.5kW motor comprises

14.3kVAR smart capacitor [CBC-8CS/480-20(10+10)+CBC-8CS/480-5(2.55+2.5)] and Accessories such as terminal blocks, cables, and a smart capacitor enclosure.

The total cost is  $19,300 + 22,000 = 41,300$  Baht.

## Annual Cost Savings

- The annual cost savings represents the total reduction in electricity expenses achieved after implementing the smart capacitors. This is primarily due to the reduction in cable losses and improved power factor.
- Cost saving Table in the report details the total annual savings, calculated to be **24,655 baht**.

## Return on Investment (ROI)

ROI of the Smart Capacitor system using the Net Present Value (NPV) method, given the following information:

- Investment: 41,100 baht      Annual Cost Savings: 24,655 baht
- Lifespan: 5 years.

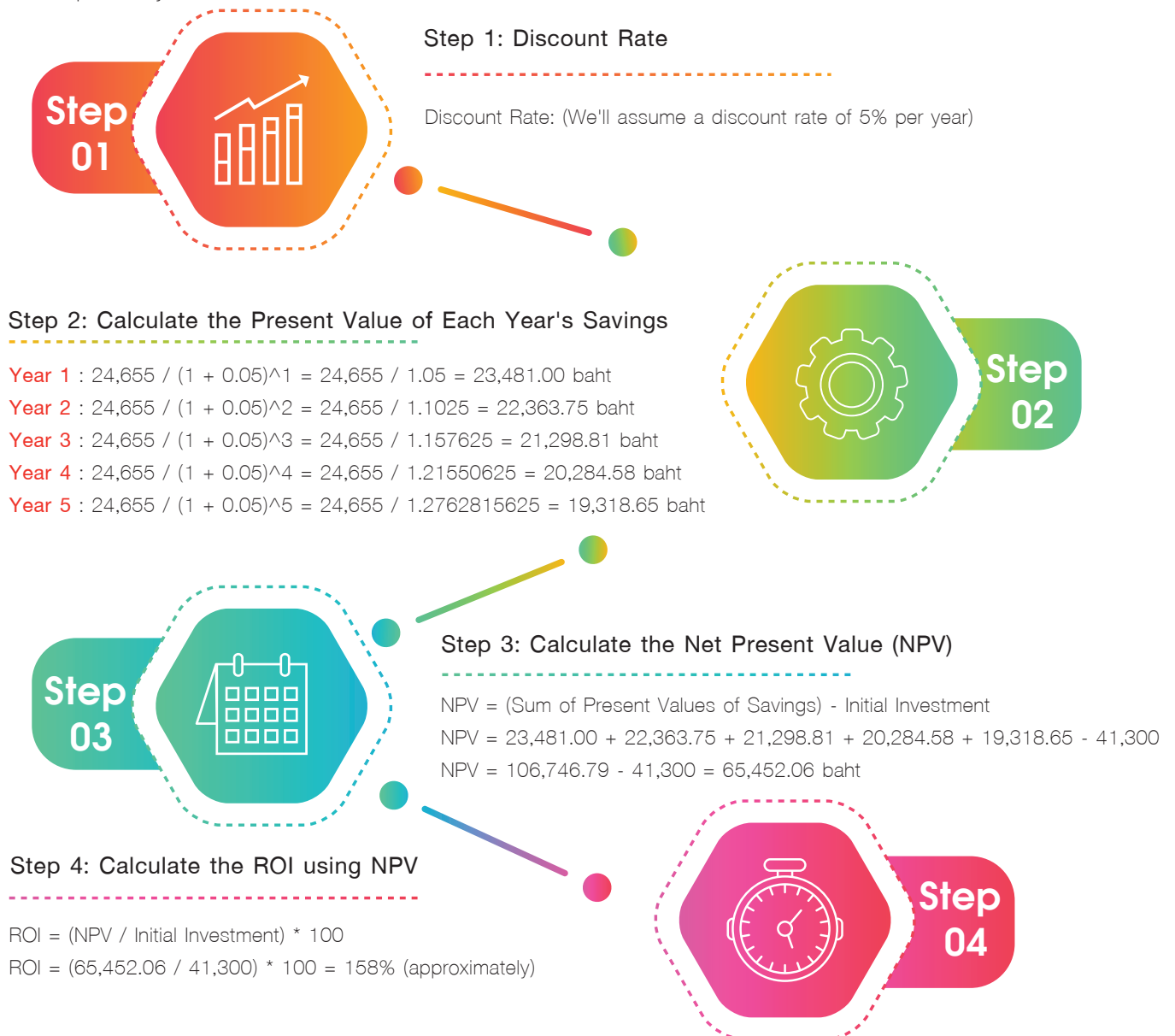

## Result:

The ROI of the Smart Capacitor system, calculated using the NPV method with a 5% discount rate, is approximately 158%.



## Payback Period

The payback period is the length of time it takes for the cumulative cost savings to equal the initial investment cost. It is calculated as follows:

- Payback Period = Initial Investment Cost / Annual Cost Savings

**In this case:**

Payback Period = 41,300 / 24,655 baht/year = 1.68 years

Therefore, the payback period for the smart capacitor project is approximately 1.68 years.

This means it will take about 1 year and 8 months for the cost savings to fully recover the initial investment.



# Smart Capacitor Cabinet

Easy Installation

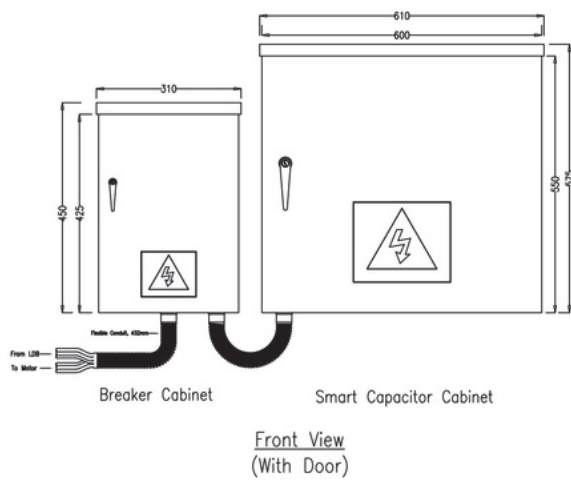

Built - In PF Controller  
**CBC** Smart Capacitor

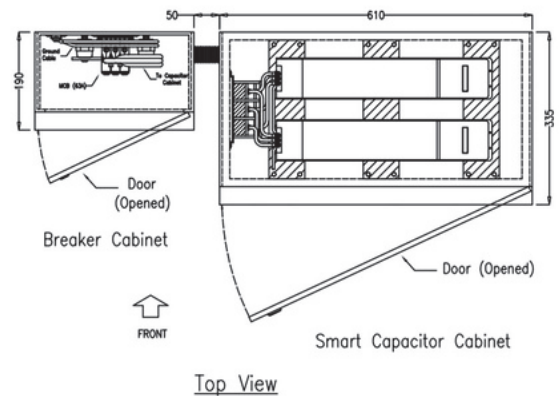
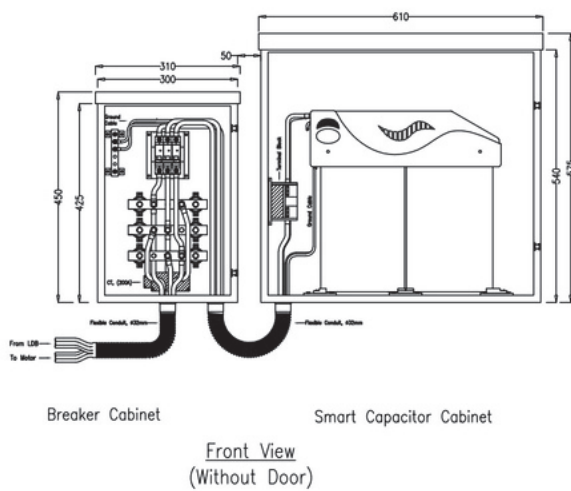



Power Smart, Save Big  
Minimize Motor Cable Losses  
with CBC Smart Capacitors