

SPECIFICATION
OIL IMMERSED TRANSFORMER
315 KVA. 3 Ph. 50 Hz
22000 - 400 / 230 V.

TCT THAI CENTER TRANSFORMER CO.,LTD
SPECIFICSTION THREE PHASE TRANSFORMER

Address : 67 / 1 Moo. 7 T. Bangkam A. Maung Nakhonpathom 73000

Tel . 081 - 8054856 , 034 - 219036 Fax 034 - 984092 <http://www.thaicentertransformer.com> e - mail : thaicenter671@hotmail.com

Transformer Specification

Quote. Ref :

Customer :

Project :

Rated powerKVA	315	
Type of transformer	-	Oil immersed (Hermetically sealed)	
Standard	-	IEC 76	
Cooling System	-	ONAN	
No. Of phase	-	3	
FrequencyHz	50	
Rate of voltage : PrimaryV.	22000	
: SecondaryV.	400/230	
Vector group	-	Dyn 11	
Tapping Type	-	off circuit tap changer	
No. of steps	-	5	
Percentage of tapping	-	± 2 x 2.5 %	
Impedance voltage at 75 C%	4	
NO - Load current%	1	
Ambient temperatureC	40	
Average Temperature rise of windingC	65	
Average Temperature rise of top oilC	60	
Noise level not more thandB	56	
No - Load lossWatt	600	
Load loss at 75 CWatt	3500	
Efficiency at P.F. = 1	: 25 % of rate power%	98.94
	: 50 % of rate power%	98.08
	: 75 % of rate power%	98.79
	: 100 % of rate power%	98.56
Voltage regulation	: at P.F. = 0.8%	3.22
	: at P.F. = 0.9%	2.71
	: at P.F. = 1.%	1.17
Impulse Withstand Voltage	: Primary windingKV.	125
	: Secondary windingKV.	-
Power Frequency	: Primary windingKV.	50
	: Secondary windingKV.	3
Terminal arrangement H.V. Side		Cable	
L.V. Side		Cable	
Installation on		Pole mounted / Plantform	

TCT THAI CENTER TRANSFORMER CO.,LTD
SPECIFICSTION THREE PHASE TRANSFORMER

Address : 67 / 1 Moo. 7 T. Bangkam A. Maung Nakhonpathom 73000

Tel . 081 - 8054856 , 034 - 219036 Fax 034 - 984092 <http://www.thaicentertransformer.com> e - mail : thaicenter671@hotmail.com

Transformer Specification

Quote. Ref :

Customer :

Project :

Rated power	315
Type of transformer	Oil immersed (Hermetically sealed)
Accessories	
H.V. Bushing with terminal connector	Included
L.V. Bushing with terminal connector	Included
Grounding pad or earth terminal	Included
upper fillter press sampling valve	Included
Oil drain, filter press sampling valve	Included
Name plate	Included
Arcing Horn	Included
Skid Base	Included
Mechanical pressure relief device	Included (without contact)
Oil level indicator	Included (with contact)
	Included (with contact)
	Included (with contact)
Testing	
- Routine test	
Ratio test at each position of tap	Included
Polarity and phase relation test	Included
Resistance measurement	Included
No - Load loss and exciting current test	Included
Impedance and load loss test	Included
Applied potential test	Included
Induced potential test	Included
Insulation resistance test	Included
Oil test	Included
- Specia test	
Impulse withstand test	Included (Thaicenter lab)
Temperature rise test	Included (Thaicenter lab)

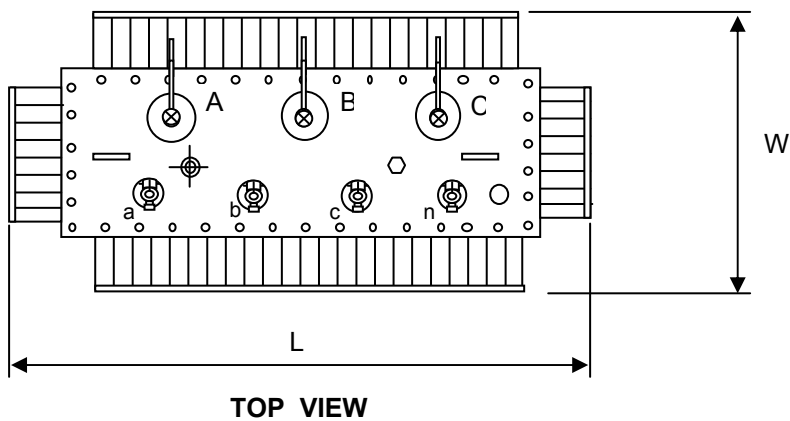
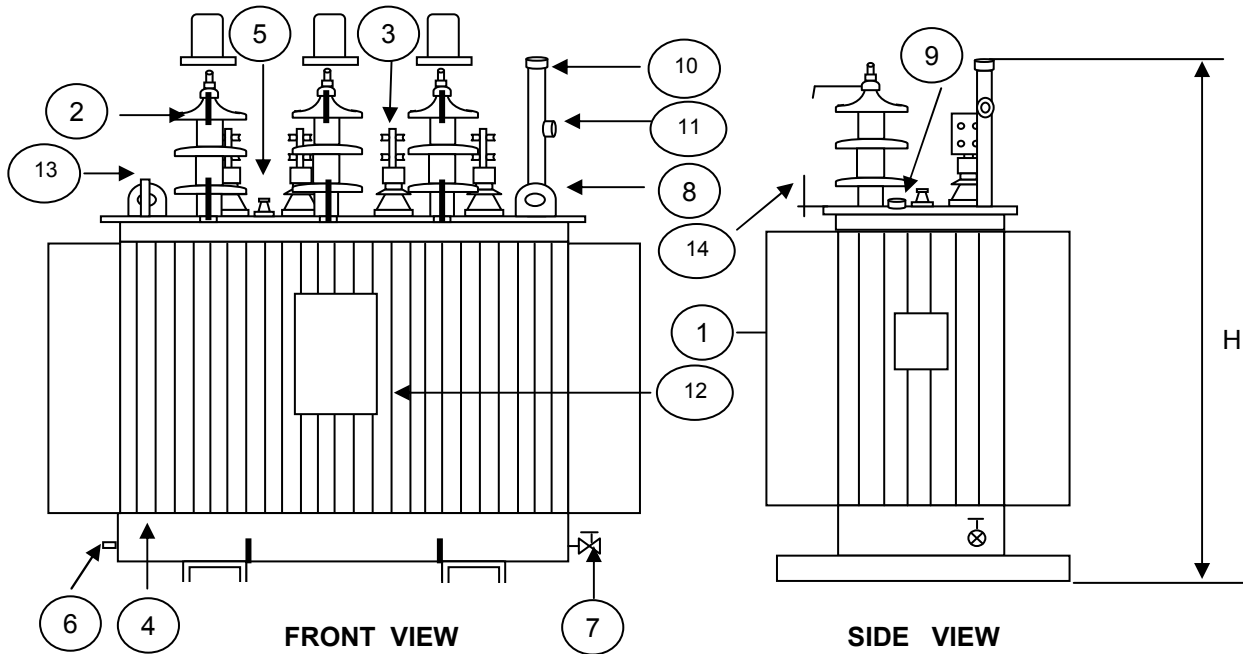

NO	DESCRIPTION	QTY.
1	NAMEPLATE WITH CONNECTION DIAGRAM	1
2	HV. BUSHING W / TERMINAL CONNECTOR	3
3	LV. BUSHING W / TERMINAL CONNECTOR	4
4	TANK	1
5	TAP CHANGE	1
6	EARTH TERMINAL	1
7	OIL DRAIN VALAE	1
8	LIFTING EYES ON THE COVER	2
9	OIL LEVEL INDICATOR	1
10	OIL FILLING PIPE	1
11	OIL LEVEL GAUGE	1
12	LOGO	1
13	THERMOMETER POCKET	1
14	ARCING HORN	3

THAI CENTER TRANSFORMER CO.,LTD					
Dimension in millimetres				Total wt.	Oil
H		L	W	(Kgs.)	(Litres)
1530 mm,		1400 mm	785 mm	1250	365
DESIGN No. 00315TCT 1 - 52009				S/O No. A52009	
NAME			TITLE : OUTLINE DRAWING		
DRN.BY			315 kVA. 3 Ph. Dyn11		
CHK.BY			22000 - 400 / 230		
APP. BY			TYPE : Hermeticall sealed tank		

PRELIMINARY DRAWING

This drawing is for estimation only showing approximate dimensions and should not be used for actual purposes
In case of order a definite drawing will be produced for formal approval