



C-18

Forged Steel valves



OMB is a family owned and managed business founded by Mr. Roberto Brevi in 1973. His goal was to build a company that would specialize in the manufacturing of Forged Steel valves. Since its founding, OMB's capabilities have grown to cover small diameter Gate/Globe/Check valves, small and large diameter Floating and Trunnion Mounted Ball valves, Through Conduit Gate valves, and triple offset butterfly valves. Today OMB operates 8 plants in 5 countries with a worldwide network of agents, distributors and sales offices.

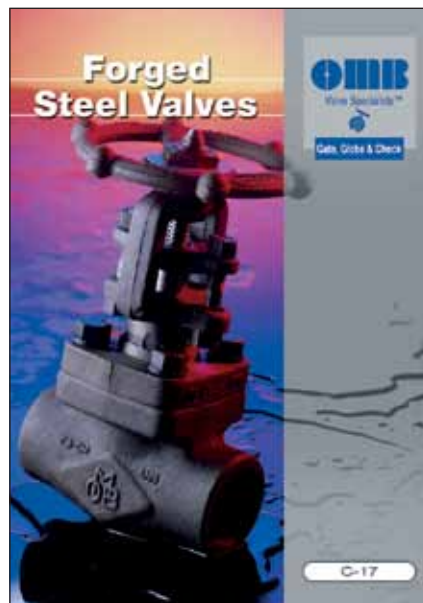

NEW IN THIS CATALOG

C-18 presents the API602/ISO15761 Forged Steel valves line. OMB has produced these valves since 1973 and is one of the world leading manufacturers with an extensive list of customer approvals and international standards certifications. In this new version of the catalog we introduce a revised figure number table, new available materials table and new designs.

The content of this catalog is copyrighted by OMB Valves S.p.A. (c) 2009. Nothing included in this catalog can be reproduced in any form without obtaining prior written consent by OMB Valves S.p.A. All photos and images published are copyrighted; the use of images, even if digitally modified to take away the OMB logo will be prosecuted to the maximum extent of the law.

C-17 previous edit



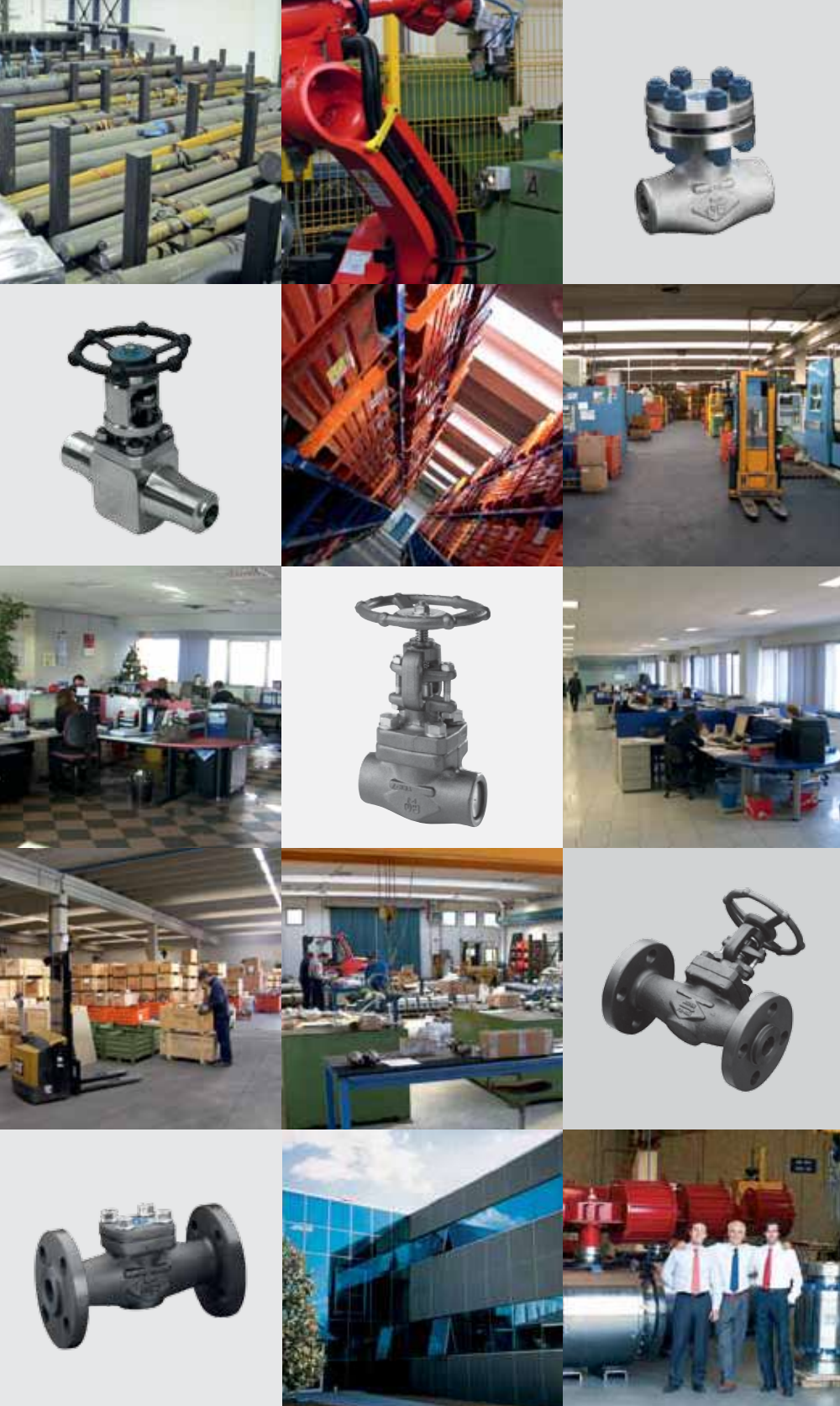

OMB has developed a comprehensive range of engineered valve products installed globally across a wide variety of industries:

- Offshore
- Subsea
- Refining
- Petrochemical
- Chemical
- Desalination

In the past forty years, OMB has supplied millions of valves to many of the world's largest Oil and Gas companies. During this time, OMB's name has become synonymous with absolute reliability, superior quality, and competitive pricing.

In the early 80's OMB was the first valves company to introduce robotics in its manufacturing processes; adding specialized equipment designed to reduce cycle time and increase the quality of the machined components.

Nowadays OMB's commitment to innovation and continuous improvement is more important than ever. With this end in mind, at OMB we focus on expanding our production capacity by opening new plants abroad, and improving our customer's service by extending the distribution network to new levels.

We invite you to visit any of our facilities. You'll meet our experienced personnel and see the state of the art equipment we use to produce the best quality world-class valves that money can buy.

This our promise!

Roberto, Simone and Fabio Brevi

The Brevi family is active in the management of the operations.

Roberto Brevi, Founder and Chairman with Simone and Fabio Managing Directors.

OMB is based in Bergamo, the world center of the Forged Steel valves production, a city located 45 Km NE from Milan with easy access to airports, highways and seaports.





CRYOGENIC VALVES

Catalog C-CR2 presents the Forged Steel Gate, Globe and Check valves for Cryogenic and Low Temperature service.

Includes valves with Extended Bonnet and Cryogenic and Low Temperature ball valves.



BELLOWS SEAL VALVES

Catalog C-BS2 presents the Forged & Cast Steel product line of Bellows Sealed Gate, "T"-Pattern Globe and "Y"-Pattern Globes valves.

Valves are offered in pressure Classes from 150 to 2500, with bellows in 321, Alloy 625 and Hastelloy® C276 materials. This catalog also includes Cast Steel valves in accordance with API600 from 2" to 16".





HIGH PRESSURE & TEMPERATURE

Catalog C-YV2 introduces OMB's valves product line for the power and energy industries: "Y"-Pattern Globe valves up to Class 4500, Welded Bonnet and Pressure Seal construction Gate, Globe and Check valves and Parallel Slide Gate valves for steam service. The catalog includes information on pressure-temperature rating of all alloyed materials used for high temperature services.

API6A-ISO10423

Catalog C-API6A1 introduces the latest product developments for the upstream Oil and Gas applications. It includes the complete range of API6A Through Conduit Gate valves, with expanding and solid (slab) Gates, Ball valves, Globe valves and Piston and Swing Check valves from Class 3000 and above.





Achilles



API 6A - 0778



API 6A - 0286



ATEX



PED



Gost-R



ISO 15848



SIL II-III Certified



ISO 9001

All OMB certificates are available for free download on our web site: www.ombvalves.com

OMB KEY PRINCIPLES RELATING TO ENVIRONMENT, HEALTH AND SAFETY POLICY

OMB considers it is strategically important for the satisfaction of its customers, employees, visitors, suppliers and the community in which it operates, to achieve standards of excellence in the field of health, safety at work and environmental protection.

It is a priority in corporate management to protect and promote respect for the environment and health and safety at work of all employees in order to ensure long-term sustainability of the business.

All OMB employees, in accordance with their skills and their role, are compelled to integrate this policy in their business processes, to adopt the key principles listed below and to be actively involved in the growth of the management system with comments and suggestions for improvement.



KEY PRINCIPLES:

- To ensure full compliance with current legislation, standards of good practice, through specific company standards, constantly evaluating the correct and proper implementation of the laws, regulations and contractual obligations.
- To maintain a healthy work environment in the use of products, equipment and methods of work with low risk, motivating and encouraging all employees to achieve the goal of zero accidents, occupational diseases and injuries.
- Analyze potential hazards, of dangerous situations, missed incidents or incidents, injuries in order to identify the root causes and to prevent the recurrence.
- To evaluate any possible negative environmental impacts related to its business, its products and its services, such as reduction of waste and emissions, including CO₂, rationalizing the use of non-renewable resources, by focusing on feasible, short and medium term objectives.
- To increase awareness, to inform and train the management and all the employees in order to improve the wealth of knowledge and expertise that applies to social objectives and core business in terms of safety, health and environmental protection.
- To promote cooperation and coordination with customers, suppliers and contractors communicating and exchanging the knowledge of procedures and requirements for health, safety and environment.
- To periodically check the operating and forecasting practices in order to assess compliance with the policy of environmental protection, health and safety at work.
- Interact with associations, authorities and general public institutions, in compliance with the principle of transparency.
- To spread the knowledge of environmental and health and safety policy, business strategy and the results achieved, inside and outside the company, involving public authorities, customers and the public.

OMB environment, health and safety policy, based on these key principles, is sized according to the nature and volume of the activities, to the impacts on the environment and on health and safety aspects.

The policy includes the commitment to continuous improvement and compliance with current legislation.

It also provides the framework for setting and reviewing environmental objectives and environment, health and safety goals defined by OMB.

It will be necessary to initiate a procedure for the identification of environmental aspects and risks, which will be reflected in the initial environmental analysis, in the assessment of risks to the safety and health at work.



FORGED VALVES FIGURE NUMBER SYSTEM

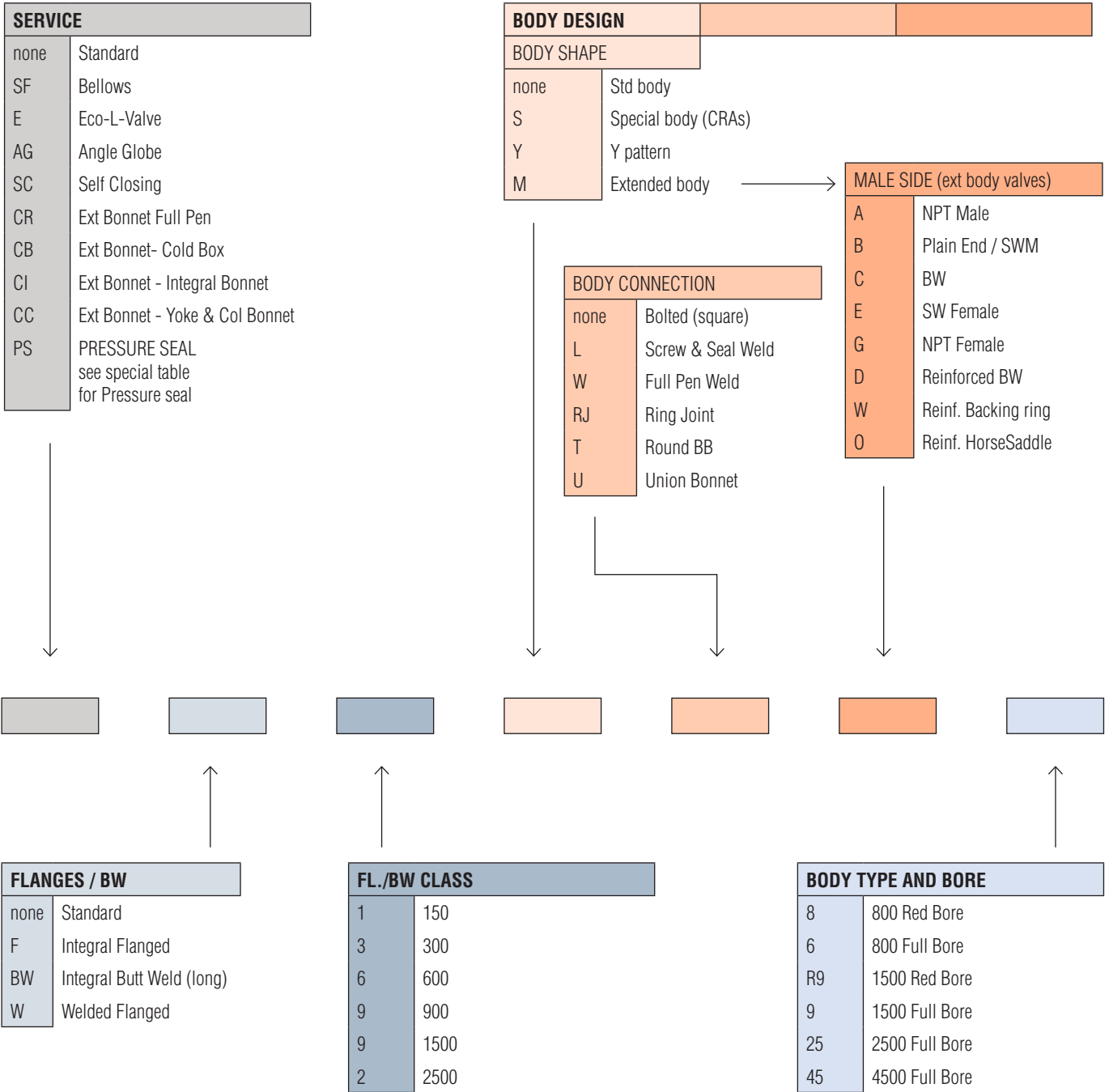

EXAMPLE

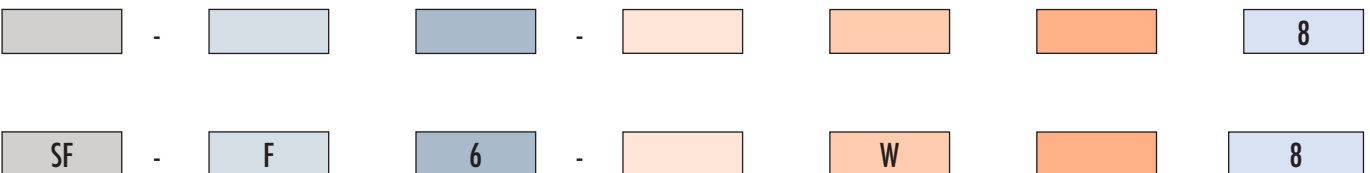

FORGED VALVES FIGURE NUMBER SYSTEM



TRIM DESIGN

OBTURATOR

none	std
A	High Regulating Cone
X	Flex Wedge
S	Needle
P	Parabolic Disc
K	Stop Check
D	Soft Disc Insert
C	Flow Control
H	Bleed Hole

DISC

none	Std.
I	Integral Seat
T	Soft Seat Insert
WS	Welded Seat (gate)

STEM

none	Std.
N	Not Rotating Stem

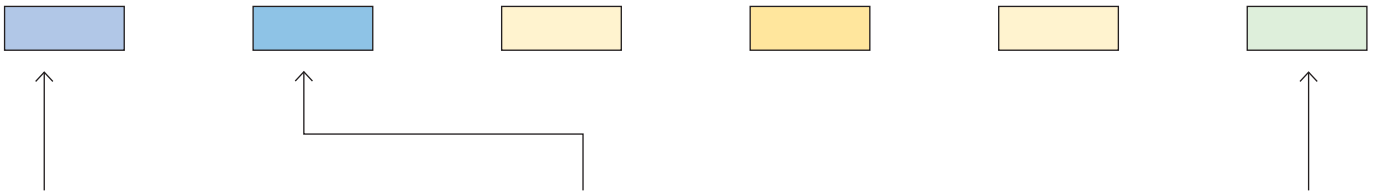

VALVE TYPE

0	Gate, IS&Y
1	Gate, OS&Y
2	Globe, IS&Y
3	Globe, OS&Y
4	Check, Piston
5	Check Ball
6	Check Swing

DIAMETER

1	1/4"
2	3/8"
3	1/2"
4	3/4"
5	1"
6	1.1/4"
7	1.1/2"
8	2"
9	2.1/2"
A	3"
B	4"

ENDS

NPT	Threaded Ends
SW	Socket Weld
SWxNPT	SW x NPT
NPTxSW	NPT x SW
SH10	Schedule 10
SH40	Schedule 40
SH80	Schedule 80
SH160	Schedule 160
SHXXS	Schedule XXS
RF	Raised Face - Smooth Finish 3.2-6.3 - Spiral
RJ	Ring Joint

0 General serie number



= 810 SW

800 Red Bore, Gate, OS&Y, Socket Weld Ends



= SF-F6-W830-RF

BELLOWS, INTEGRAL FLANGED 600, FULL PEN WELD
800 RED BORE BODY, GLOBE, OS&Y, RF ENDS



	GATE						GLOBE						CHECK						GLOBE & CHECK Y PATTERN								
	FORGED						FORGED						FORGED						FORGED								
	RF - BW - SW						RF-BW-SW						RF-BW-SW						RF-BW-SW								
	#150	#300	#600	#800	#1500	#2500	#150	#300	#600	#800	#1500	#2500	#4500	#150	#300	#600	#800	#1500	#2500	#4500	#150	#300	#600	#800	#1500/#1690	#2500/#2680	#4500
1/2"	Green						Teal						Orange						Blue								
3/4"	Green						Teal						Orange						Blue								
1"	Green						Teal						Orange						Blue								
1.1/2"	Green						Teal						Orange						Blue								
2"	Green						Teal						Orange						Blue								
3"																									Blue	Blue	
4"																									Blue		
6"																											

	GATE	GLOBE	CHECK	GLOBE & CHECK Y PATTERN
Specification Reference	ISO 15761 ed.2, 2002 API 602 ed.10, 2015 ASME B16.34 ed. 2013	ISO 15761 ed.2, 2002 API 602 ed.10, 2015 ASME B16.34 ed. 2013	ISO 15761 ed.2, 2002 API 602 ed.10, 2015 ASME B16.34 ed. 2013	ASME B16.34 ed. 2013
Valves design	Bolted or Welded	T-Pattern Bolted or Welded	T-Pattern Bolted or Welded	Y-Pattern Bolted or Welded
Size range	size 1/4"-2"	size 1/4"-2"	size 1/4"-2"	size 1/4"-4"
Body construction	Closed Die Forging	Closed Die Forging	Close Die Forging	Closed Die Forging
Bore construction	Full and Standard Bore	Full and Standard Bore	Full and Standard Bore	Full Bore
ASME Class	150, 300, 600, 800, 1500, 2500	150, 300, 600, 800, 1500, 2500, 4500	150, 300, 600, 800, 1500, 2500, 4500	150, 300, 600, 800, 1500, 1690, 2500, 2680, 4500





GATE

- Sizes 1/4" through 2"
- Closed Die Forging
- Full and Standard Bore
- Class 150
- Class 300
- Class 600
- Class 1500
- Class 2500
- Bolted or welded bonnet

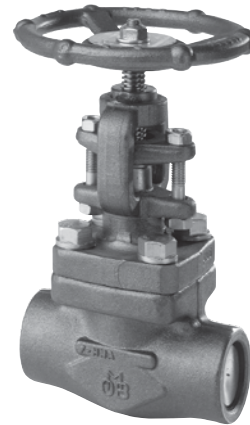

GLOBE

- Sizes 1/4" through 2"
- Closed Die Forging
- Full and Standard Bore
- Class 150
- Class 300
- Class 600
- Class 800
- Class 1500
- Class 2500
- Class 4500
- T-Pattern, bolted or welded bonnet



CHECK

- Sizes 1/4" through 2"
- Closed Die Forging
- Full and Standard Bore
- Class 150
- Class 300
- Class 600
- Class 800
- Class 1500
- Class 2500
- Class 4500
- T-Pattern, bolted or welded bonnet



GLOBE & CHECK Y PATTERN

- Sizes 1/4" through 4"
- Closed Die Forging
- Full Bore
- Class 150, 300, 600 (welded flanges)
- Class 800
- Class 1500
- Class 1690
- Class 2500
- Class 2680
- Class 4500
- Bolted or welded bonnet





Gate valves are bi-directional valves ideally suited for on-off duties OMB produces various types, with parallel face gates or wedge gates (as closure elements).

These valves have a high flow coefficient (Cv), and in the case of parallel gate valves, it is comparable with the straight pipe's Cv. They are usually installed in high pressure fluids applications because the upstream pressure helps the sealing between gate and seat.

OMB is continuously studying and improving the surface finish of the seating in order to guarantee the minimum wear under high pressure conditions.

Gate valves are supplied in various models that cover a wide range of different and unique services.

CONSTRUCTION

ISO15761 2nd ed., 2002
API602 10th.ed., 2015
ASME B16.34 2013 ed.

Bolted or
welded bonnet

size 1/2"-2"

Closed Die Forging

Full and Standard Bore

150, 300, 600,
800, 1500, 2500



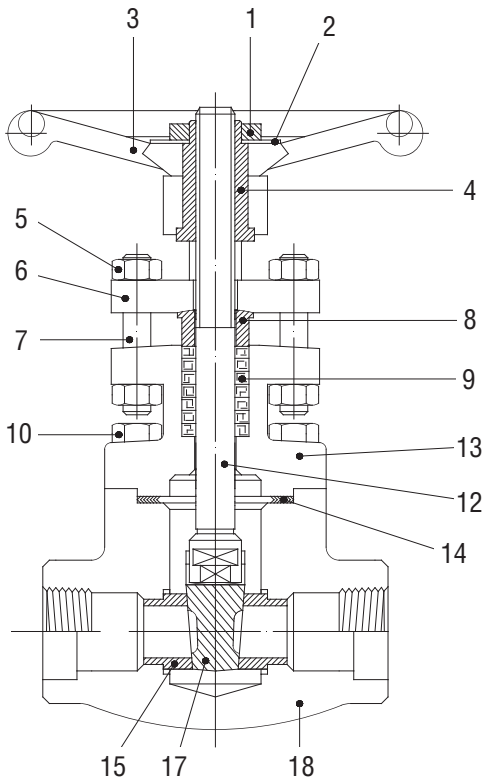

1	WHEELNUT	Austenitic ductile iron, 13Cr steel, or copper alloy having a melting point above 955°C (1750 °F).
2	NAMEPLATE	A corrosion resistant metal.
3	HANDWHEEL	Malleable iron, carbon steel, or ductile iron.
4	YOKE NUT	Carbon steel, stainless steel or similar material composition as the bonnet.
5	GLAND NUT	Bolting materials of a Type 300 or Type 400 series stainless steel. Also, material at least equal to either ASTM A307-Grade B or EN 10269-C35E (1.1181) may be used for yoke bolting.
6	GLAND FLANGE	Steel.
7	GLAND STUD	Unless other materials are agreed between the purchaser and manufacturer, refer to the recommended bolting material in Annex G of API 602.
8	GLAND	Material with a melting point above 955° C (1750 °F).
9	PACKING (*)	Non-asbestos material suitable for steam and petroleum fluids over a temperature range of - 29 °C to 540 °C (-20 °F to 1000 °F) and containing a corrosion inhibitor.
10	BOLTS	Unless other materials are agreed between the purchaser and manufacturer, refer to the recommended bolting material in Annex G of API 602.
12	STEM	Refer to API Standard 602, Table 12.
13	BONNET	A forging, forged bar or casting material as selected from ASME B16.34, Group 1, 2 or Group 3 listed in table 1.
14	GASKET	Refer to API Standard 602 (see 5.5.3).
15	SEAT	The base material of the seat ring, when used, shall be of a nominal material composition equal to the body material or the stem material Refer to API 602 (see 6.1.4).
17	WEDGE	The base material of the wedge/disc shall be of a nominal material composition equal to the body material or the stem material. Refer to API 602 (see 6.1.4).
18	BODY	A forging, forged bar or casting material as selected from ASME B16.34, Group 1, 2 or Group 3 listed in table 1.

DESCRIPTION	A105N/F6	A105N/F6HFS	LF2-316	F11/F6HFS	F304-304	F316-316
WHEELNUT	Galvanized AVP	Galvanized AVP	Galvanized AVP	Galvanized AVP	303	303
NAMEPLATE	Aluminium	Aluminium	Aluminium	Aluminium	Aluminium	Aluminium
HANDWHEEL	Carbon Steel	Carbon Steel	Carbon Steel	Carbon Steel	Carbon Steel +Black Epoxy	Carbon Steel +Black Epoxy
YOKE NUT	416	416	416	416	416	416
GLAND NUT	2H	2H	Gr.8M	Gr.8M	Gr.8	Gr.8
GLAND FLANGE	A105	A105	LF2	F6a Cl.2	304/304L	316
GLAND STUD	F6a Cl.2 (410)	F6a Cl.2 (410)	B8M CL.1	B8M CL.1	B8 CL.1	B8 CL.1
GLAND	316	316	316	316	316	316
PACKING (*)	Graphite	Graphite	Graphite	Graphite	Graphite	Graphite
BOLTS	B7	B7	L7	B16	B8 CL.1	B8 CL.1
STEM	F6a Cl.2 (410)	F6a Cl.2 (410)	316/316L	F6a Cl.2 (410)	304/304L	316
BONNET	A105N	A105N	LF2	304/304L	304/304L	F316
GASKET	316+Graphite	316+Graphite	316+Graphite	316+Graphite	316+Graphite	Sp. Wound
SEAT	F6a Cl.2 (410)	410 HF	316/316L	410 HF	304/304L	316/316L
WEDGE	F6a Cl.2	F6a Cl.2	316/316L	F6a Cl.2	304/304L	316
BODY	A105N	A105N	LF2	F11 Cl.2	304/304L	316



810/610

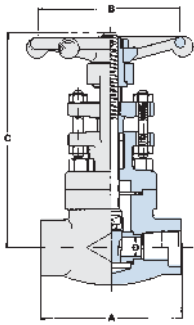

RATINGS: Carbon Steel 1975 p.s.i. @ 100°F

CLASS 800 BOLTED BONNET - STANDARD AND FULL - API602 - ISO 15761

Outside Screw & Yoke - Threaded and Socket Weld Ends to B16.11

STANDARD BORE	810	-	1/2	3/4	1	1 1/4	1 1/2	2	-						
FULL BORE	610	1/4	3/8	1/2	3/4	1	1 1/4	1 1/2	2						
		mm	in	mm	in	mm	in	mm	in	mm	in	mm	in	mm	in
End to End*	A	80	3.14	80	3.14	90	3.54	110	4.33	127	5.00	127	5.00	150	5.90
Handwheel	B	80	3.14	80	3.14	80	3.14	110	4.33	110	4.33	130	5.11	130	5.11
Open Center to Top	C	148	5.86	148	5.86	163	6.41	178	7.00	210	8.26	243	9.56	262	10.3
Flow Passageway	D	8	0.31	9.6	0.38	14	0.55	18	0.70	24	0.94	30	1.18	37	1.45
Approx. Weight	kg/lb	1.6	3.5	1.6	3.5	2.2	4.8	3.5	7.7	5	11	6.5	14.3	9	19.8

*End to End OMB standard

L810/L610

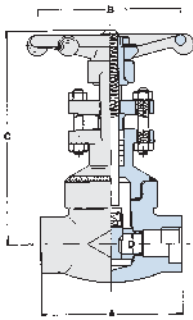

RATINGS: Carbon Steel 1975 p.s.i. @ 100°F

CLASS 800 WELDED BONNET - STANDARD AND FULL - API602 - ISO 15761

Outside Screw & Yoke - Threaded and Socket Weld Ends to B16.11

STANDARD BORE	L810	-	1/2	3/4	1	1 1/4	1 1/2	2	-						
FULL BORE	L610	1/4	3/8	1/2	3/4	1	1 1/4	1 1/2	2						
		mm	in	mm	in	mm	in	mm	in	mm	in	mm	in	mm	in
End to End*	A	80	3.14	80	3.14	90	3.54	110	4.33	127	5.00	127	5.00	150	5.90
Handwheel	B	80	3.14	80	3.14	80	3.14	110	4.33	110	4.33	130	5.11	130	5.11
Open Center to Top	C	148	5.86	148	5.86	163	6.41	178	7.00	210	8.26	243	9.56	262	10.3
Flow Passageway	D	8	0.31	9.6	0.38	14	0.55	18	0.70	24	0.94	30	1.18	37	1.45
Approx. Weight	kg/lb	1.6	3.5	1.6	3.5	2.2	4.8	3.5	7.7	5	11	6.3	13.8	8	17.6

*End to End OMB standard

800/600

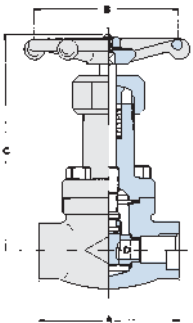

RATINGS: Carbon Steel 1975 p.s.i. @ 100°F

CLASS 800 BOLTED BONNET - STANDARD AND FULL - API602 - ISO 15761

Inside Screw & Yoke - Threaded and Socket Weld Ends to B16.11

STANDARD BORE	800	-	1/2	3/4	1	1 1/4	1 1/2	2	-						
FULL BORE	600	1/4	3/8	1/2	3/4	1	1 1/4	1 1/2	2						
		mm	in	mm	in	mm	in	mm	in	mm	in	mm	in	mm	in
End to End*	A	80	3.14	80	3.14	90	3.54	110	4.33	127	5.00	127	5.00	150	5.90
Handwheel	B	80	3.14	80	3.14	80	3.14	110	4.33	110	4.33	130	5.11	130	5.11
Open Center to Top	C	148	5.86	148	5.86	175	6.88	212	8.34	235	9.25	287	11.3	327	12.9
Flow Passageway	D	8	0.31	9.6	0.38	14	0.55	18	0.70	24	0.94	30	1.18	37	1.45
Approx. Weight	kg/lb	1.6	3.5	1.6	3.5	2.2	4.8	3.5	7.7	5	11	6.3	13.8	8	17.6

*End to End OMB standard

L800/L600

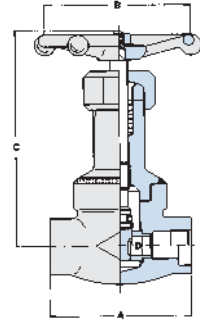

RATINGS: Carbon Steel 1975 p.s.i. @ 100°F

CLASS 800 WELDED BONNET - STANDARD AND FULL - API602 - ISO 15761

Inside Screw & Yoke - Threaded and Socket Weld Ends to B16.11

STANDARD BORE	L800	-	1/2	3/4	1	1 1/4	1 1/2	2	-						
FULL BORE	L600	1/4	3/8	1/2	3/4	1	1 1/4	1 1/2	2						
		mm	in	mm	in	mm	in	mm	in	mm	in	mm	in	mm	in
End to End*	A	80	3.14	80	3.14	90	3.54	110	4.33	127	5.00	127	5.00	150	5.90
Handwheel	B	80	3.14	80	3.14	80	3.14	110	4.33	110	4.33	130	5.11	130	5.11
Open Center to Top	C	148	5.86	148	5.86	175	6.88	212	8.34	235	9.25	287	11.3	327	12.9
Flow Passageway	D	8	0.31	9.6	0.38	14	0.55	18	0.70	24	0.94	30	1.18	37	1.45
Approx. Weight	kg/lb	1.5	3.3	1.5	3.3	2	4.4	3	6.6	5.1	11.2	6.5	14.3	9	19.8

*End to End OMB standard

Dimensions and weights are subject to change without notice.

OMB reserves the rights to make modifications or changes to its production, without any prior notice. Dimensions and weights are subject to change without notice.



R910/910

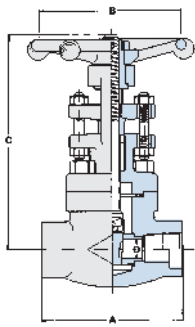

RATINGS: Carbon Steel 3705 p.s.i. @ 100°F

CLASS 1500 BOLTED BONNET - STANDARD AND FULL - API602 - ISO 15761

Outside Screw & Yoke - Threaded and Socket Weld Ends to B16.11

STANDARD BORE	R910	-		1/2		3/4		1		1 1/4		1 1/2		2		-	
FULL BORE	910	1/4		3/8		1/2		3/4		1		1 1/4		1 1/2		2	
		mm	in	mm	in	mm	in	mm	in	mm	in	mm	in	mm	in	mm	in
End to End*	A	90	3.54	90	3.54	110	4.33	127	5.00	127	5.00	127	5.00	150	5.90	150	5.90
Handwheel	B	80	3.14	80	3.14	110	4.33	110	4.33	130	5.11	130	5.11	180	7.08	180	7.08
Open Center to Top	C	145	5.70	160	6.29	175	6.89	210	8.26	240	9.45	260	10.2	3.55	13.9	360	14.1
Flow Passageway	D	8	0.31	9.6	0.38	14	0.55	18	0.70	24	0.94	30	1.18	37	1.45	40	1.57
Approx. Weight	kg/lb	2.2	4.8	2.2	4.8	3.8	8.3	5.5	12.1	6.8	14.9	9.5	20.9	22.5	49.5	22	48.4

*End to End OMB standard

LR910/L910

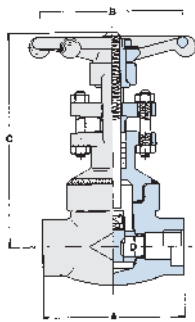

RATINGS: Carbon Steel 3705 p.s.i. @ 100°F

CLASS 1500 WELDED BONNET - STANDARD AND FULL - API602 - ISO 15761

Outside Screw & Yoke - Threaded and Socket Weld Ends to B16.11

STANDARD BORE	LR910	-		1/2		3/4		1		1 1/4		1 1/2		2		-	
FULL BORE	L910	1/4		3/8		1/2		3/4		1		1 1/4		1 1/2		2	
		mm	in	mm	in	mm	in	mm	in	mm	in	mm	in	mm	in	mm	in
End to End*	A	90	3.54	90	3.54	110	4.33	127	5.00	127	5.00	127	5.00	150	5.90	150	5.90
Handwheel	B	80	3.14	80	3.14	110	4.33	110	4.33	130	5.11	130	5.11	180	7.08	180	7.08
Open Center to Top	C	145	5.70	160	6.29	175	6.89	210	8.26	240	9.45	260	10.2	3.55	13.9	360	14.1
Flow Passageway	D	8	0.31	9.6	0.38	14	0.55	18	0.70	24	0.94	30	1.18	37	1.45	40	1.57
Approx. Weight	kg/lb	2.2	4.8	2.2	4.8	3.8	8.3	5.5	12.1	6.8	15	9	19.8	18.0	39.6	17.5	38.5

*End to End OMB standard

RJ910

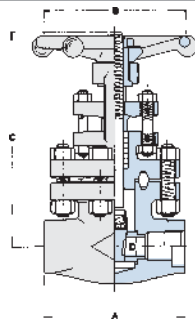

RATINGS: Carbon Steel 3705 p.s.i. @ 100°F

CLASS 1500 ROUND BOLTED BONNET RJ - FULL BORE - API602 - ISO 15761

Outside Screw & Yoke - Threaded and Socket Weld Ends to B16.11

FULL BORE	RJ910	1/4		3/8		1/2		3/4		1		1 1/4		1 1/2		2	
		mm	in	mm	in	mm	in	mm	in	mm	in	mm	in	mm	in	mm	in
End to End*	A	-	-	-	-	110	4.33	150	5.90	150	5.90	-	-	210	8.26	235	9.25
Handwheel	B	-	-	-	-	110	4.33	130	5.11	130	5.11	-	-	180	7.08	250	9.84
Open Center to Top	C	-	-	-	-	227	8.93	300	11.8	307	12	-	-	400	15.7	488	17.6
Flow Passageway	D	-	-	-	-	14	0.55	18	0.70	24	0.94	-	-	37	1.45	48	1.89
Approx. Weight	kg/lb	-	-	-	-	5	11.0	10	22.0	11.5	25.3	-	-	22	48.4	37	81.5

*End to End OMB standard

Ring-Joint gasket according to ASME B16.20 - API 6A.

BW9-RJ910

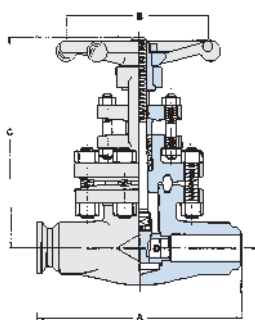

RATINGS: Carbon Steel 3705 p.s.i. @ 100°F

CLASS 1500 ROUND BOLTED BONNET RJ - FULL BORE - API 602 - ISO 15761

Outside Screw & Yoke - Butt Welded and Clamp Ends to B16.25

FULL BORE	BW9-RJ910	1/4		3/8		1/2		3/4		1		1 1/4		1 1/2		2	
		mm	in	mm	in	mm	in	mm	in	mm	in	mm	in	mm	in	mm	in
End to End*	A	-	-	-	-	216	8.50	229	9.01	254	10.0	-	-	305	12.0	368	14.5
Handwheel	B	-	-	-	-	110	4.33	130	5.11	130	5.11	-	-	180	7.08	300	11.8
Open Center to Top	C	-	-	-	-	260	10.2	300	11.8	300	11.8	-	-	390	15.3	420	16.5
Flow Passageway	D	-	-	-	-	14	0.55	18	0.70	24	0.94	-	-	37	1.45	48	1.89
Approx. Weight	kg/lb	-	-	-	-	9	19.8	12	26.4	13	28.6	-	-	26	57.2	44	96.9

*End to End ASME B16.10



RJ2510

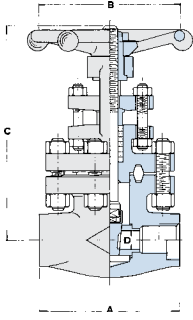

RATINGS: Carbon Steel 6170 p.s.i. @ 100°F

CLASS 2500 ROUND BOLTED BONNET RJ - FULL BORE - ASME B16.34

Outside Screw & Yoke - Threaded and Socket Weld Ends to B16.11

FULL BORE	RJ2510	1/4		3/8		1/2		3/4		1		1 1/4		1 1/2		2	
		mm	in	mm	in	mm	in	mm	in	mm	in	mm	in	mm	in	mm	in
End to End*	A	-	-	-	-	150	5.90	150	5.90	210	8.26	-	-	235	9.25	235	9.25
Handwheel	B	-	-	-	-	130	5.11	130	5.11	250	9.84	-	-	300	11.8	300	11.8
Open Center to Top	C	-	-	-	-	293	11.5	300	11.8	390	15.3	-	-	435	17.1	435	17.1
Flow Passageway	D	-	-	-	-	14	0.55	18	0.70	24	0.94	-	-	37	1.45	37	1.45
Approx. Weight	kg/lb	-	-	-	-	10	22.0	10.3	22.7	22.4	49.3	-	-	38	83.7	38	83.7

*End to End OMB standard

Ring-Joint gasket according to ASME B16.20 - API 6A.

BW25-RJ2510

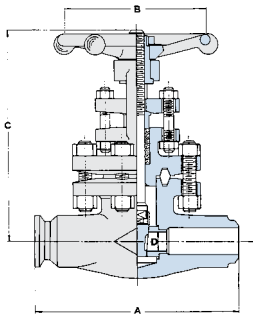

RATINGS: Carbon Steel 6170 p.s.i. @ 100°F

CLASS 2500 ROUND BOLTED BONNET RJ - FULL BORE - ASME B16.34

Outside Screw & Yoke - Butt Weld and Clamp Ends to B16.25

FULL BORE	BW25-RJ2510	1/4		3/8		1/2		3/4		1		1 1/4		1 1/2		2	
		mm	in	mm	in	mm	in	mm	in	mm	in	mm	in	mm	in	mm	in
End to End*	A	-	-	-	-	264	10.4	273	10.7	308	12.1	-	-	384	15.1	451	17.7
Handwheel	B	-	-	-	-	130	5.11	130	5.11	250	9.84	-	-	300	11.8	300	11.8
Open Center to Top	C	-	-	-	-	304	11.9	315	12.4	368	14.5	-	-	445	17.5	538	21.2
Flow Passageway	D	-	-	-	-	14	0.55	18	0.70	24	0.94	-	-	37	1.45	37	1.45
Approx. Weight	kg/lb	-	-	-	-	15	33.0	17	37.4	33	72.6	-	-	51	112.3	75	165.1

*End to End ASME B16.10

Ring-Joint gasket according to ASME B16.20 - API 6A.

L2510

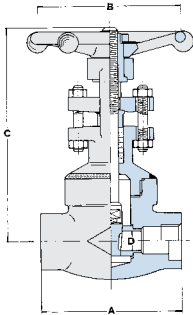

RATINGS: Carbon Steel 6170 p.s.i. @ 100°F

CLASS 2500 WELDED BONNET - FULL BORE - ASME B16.34

Outside Screw & Yoke - Threaded and Socket Weld Ends to B16.11

FULL BORE	L2510	1/4		3/8		1/2		3/4		1		1 1/4		1 1/2		2	
		mm	in	mm	in	mm	in	mm	in	mm	in	mm	in	mm	in	mm	in
End to End*	A	-	-	-	-	127	5.0	127	5.0	127	5.0	-	-	235	9.25	235	9.25
Handwheel	B	-	-	-	-	130	5.11	130	5.11	180	7.08	-	-	300	11.8	300	11.8
Open Center to Top	C	-	-	-	-	214	8.42	239	9.40	253	9.96	-	-	425	16.7	430	16.9
Flow Passageway	D	-	-	-	-	14	0.55	18	0.70	24	0.94	-	-	36.5	1.43	36.5	1.43
Approx. Weight	kg/lb	-	-	-	-	5.8	12.7	7	15.4	10	22.0	-	-	26	57.3	25.5	56.2

*End to End OMB standard

BW25-L2510

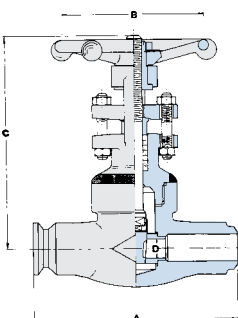

RATINGS: Carbon Steel 6170 p.s.i. @ 100°F

CLASS 2500 WELDED BONNET - FULL BORE - ASME B16.34

Outside Screw & Yoke - Butt Weld and Clamp Ends to B16.25

FULL BORE	BW25-L2510	1/4		3/8		1/2		3/4		1		1 1/4		1 1/2		2	
		mm	in	mm	in	mm	in	mm	in	mm	in	mm	in	mm	in	mm	in
End to End*	A	-	-	-	-	264	10.4	273	10.7	308	12.1	-	-	384	15.1	451	17.7
Handwheel	B	-	-	-	-	130	5.11	130	5.11	250	9.84	-	-	300	11.8	300	11.8
Open Center to Top	C	-	-	-	-	304	11.9	315	12.4	368	14.5	-	-	445	17.5	538	21.2
Flow Passageway	D	-	-	-	-	14	0.55	18	0.70	24	0.94	-	-	37	1.45	37	1.45
Approx. Weight	kg/lb	-	-	-	-	13	28.6	14	30.8	27	59.4	-	-	41	90.3	62	136.5

*End to End ASME B16.10

MLA-810/MLA-R910

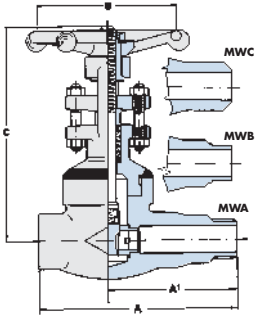

RATINGS: Carbon Steel

Class 800: 1975 p.s.i. @ 100°F - Class 1500: 3705 p.s.i. @ 100°F

CLASS 800-1500 TAKE-OFF VALVE - WELDED BONNET - STANDARD BORE - API602 - ISO 15761

Outside Screw & Yoke - Threaded, Socket Weld and BW Ends to B16.11/B16.25

STANDARD BORE	CLASS 800	MLA-810	-		1/2		3/4		1		-		1 1/2		2		-	
	CLASS 1500	MLA-R910	-		-		1/2		3/4		1		-		1 1/2		2	
			mm	in	mm	in	mm	in	mm	in	mm	in	mm	in	mm	in	mm	in
End to End*	A	-	-	148	5.82	153	6.02	182	7.16	216	8.50	216	8.50	264	10.4	264	10.4	
Center to Male End	A ₁	-	-	108	4.25	108	4.25	127	5.00	152	6.00	152	6.00	200	7.87	210	7.44	
Handwheel	B	-	-	80	3.14	80	3.14	110	4.33	110	4.33	130	5.11	130	5.11	180	7.08	
Open Center to Top	C	-	-	148	5.82	163	6.41	178	7.00	210	8.26	243	9.56	262	10.3	355	13.9	
Flow Passageway	Class 800	D	-	-	9.6	0.38	14	0.55	18	0.70	-	-	30	1.18	37	1.45	-	-
	Class 1500	D	-	-	-	-	9.6	0.38	14	0.55	18	0.70	-	-	30	1.18	37	1.45
Approx. Weight	Class 800	kg/lb	-	-	2.1	4.6	2.8	6.2	4.4	9.7	-	-	8.1	17.8	10.5	23.2	-	-
	Class 1500	kg/lb	-	-	-	-	3.1	6.8	4.8	10.6	7.5	16.5	-	-	11.5	23.5	21.1	46.5

*End to End OMB standard

MA-810/MA-R910

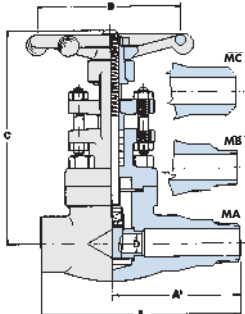

RATINGS: Carbon Steel

Class 800: 1975 p.s.i. @ 100°F - Class 1500: 3705 p.s.i. @ 100°F

CLASS 800-1500 TAKE-OFF VALVE - BOLTED BONNET - STANDARD BORE - API602 - ISO 15761

Outside Screw & Yoke - Threaded, Socket Weld and BW Ends to B16.11/B16.25

STANDARD BORE	CLASS 800	MA-810	-		1/2		3/4		1		-		1 1/2		2		-	
	CLASS 1500	MA-R910	-		-		1/2		3/4		1		-		1 1/2		2	
			mm	in	mm	in	mm	in	mm	in	mm	in	mm	in	mm	in	mm	in
End to End*	A	-	-	148	5.82	153	6.02	182	7.16	216	8.50	216	8.50	264	10.4	264	10.4	
Center to Male End	A ₁	-	-	108	4.25	108	4.25	127	5.00	152	6.00	152	6.00	200	7.87	210	7.44	
Handwheel	B	-	-	80	3.14	80	3.14	110	4.33	110	4.33	130	5.11	130	5.11	180	7.08	
Open Center to Top	C	-	-	148	5.82	163	6.41	178	7.00	210	8.26	243	9.56	262	10.3	355	13.9	
Flow Passageway	Class 800	D	-	-	9.6	0.38	14	0.55	18	0.70	-	-	30	1.18	37	1.45	-	-
	Class 1500	D	-	-	-	-	9.6	0.38	14	0.55	18	0.70	-	-	30	1.18	37	1.45
Approx. Weight	Class 800	kg/lb	-	-	2.1	4.6	2.8	6.2	4.4	9.7	-	-	8.3	18.3	12	26.4	-	-
	Class 1500	kg/lb	-	-	-	-	3.1	6.8	4.8	10.6	7.5	16.5	-	-	12	26.4	22.1	48.7

*End to End OMB standard

MLW-810/MLW-R910

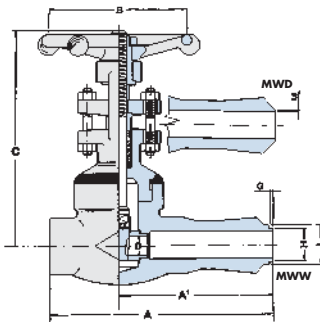

RATINGS: Carbon Steel

Class 800: 1975 p.s.i. @ 100°F - Class 1500: 3705 p.s.i. @ 100°F

CLASS 800-1500 REINFORCED EXTENDED BODY - WELDED BONNET - STANDARD BORE - API602 - ISO 15761

Outside Screw & Yoke - Threaded and Socket Weld Female Ends to B16.11

STANDARD BORE	CLASS 800	MLW-810	-		1/2		3/4		1		-		1 1/2		2		-	
	CLASS 1500	MLW-R910	-		-		1/2		3/4		1		-		1 1/2		2	
			mm	in	mm	in	mm	in	mm	in	mm	in	mm	in	mm	in	mm	in
End to End*	A	-	-	196	7.71	220	8.66	244	9.60	265	10.4	265	10.4	270	10.6	270	10.6	
Center to Male End	A ₁	-	-	156	6.14	175	6.88	189	7.44	201	7.91	201	7.91	206	8.11	220	6.50	
Handwheel	B	-	-	80	3.14	80	3.14	110	4.33	110	4.33	130	5.11	130	5.11	180	7.08	
Open Center to Top	C	-	-	148	5.82	163	6.41	178	7.00	210	8.26	243	9.56	262	10.3	355	13.9	
Flow Passageway	Class 800	D	-	-	9.6	0.38	14	0.55	18	0.70	-	-	30	1.18	37	1.45	-	-
	Class 1500	D	-	-	-	-	9.6	0.38	14	0.55	18	0.70	-	-	30	1.18	37	1.45
Approx. Weight	Class 800	kg/lb	-	-	3	6.6	3.2	7.0	5	11.0	-	-	9.3	20.5	12.5	27.5	-	-
	Class 1500	kg/lb	-	-	-	-	3.5	7.7	5.4	11.9	8.1	17.8	-	-	13	28.6	23.1	50.9

*End to End OMB standard

MW-810/MW-R910

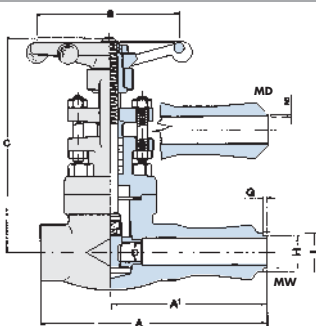

RATINGS: Carbon Steel

Class 800: 1975 p.s.i. @ 100°F - Class 1500: 3705 p.s.i. @ 100°F

CLASS 800-1500 REINFORCED EXTENDED BODY - BOLTED BONNET - STANDARD BORE - API602 - ISO 15761

Outside Screw & Yoke - Threaded and Socket Weld Female Ends to B16.11

STANDARD BORE	CLASS 800	MW-810	-		1/2		3/4		1		-		1 1/2		2		-	
	CLASS 1500	MW-R910	-		-		1/2		3/4		1		-		1 1/2		2	
			mm	in	mm	in	mm	in	mm	in	mm	in	mm	in	mm	in	mm	in
End to End*	A	-	-	196	7.71	220	8.66	244	9.60	265	10.4	265	10.4	270	10.6	270	10.6	
Center to Male End	A ₁	-	-	156	6.14	175	6.88	189	7.44	201	7.91	201	7.91	206	8.11	220	6.50	
Handwheel	B	-	-	80	3.14	80	3.14	110	4.33	110	4.33	130	5.11	130	5.11	180	7.08	
Open Center to Top	C	-	-	148	5.82	163	6.41	178	7.00	210	8.26	243	9.56	262	10.3	355	13.9	
Flow Passageway	Class 800	D	-	-	9.6	0.38	14	0.55	18	0.70	-	-	30	1.18	37	1.45	-	-
	Class 1500	D	-	-	-	-	9.6	0.38	14	0.55	18	0.70	-	-	30	1.18	37	1.45
Approx. Weight	Class 800	kg/lb	-	-	3	6.6	3.2	7.0	5	11.0	-	-	9.5	20.9	12.5	27.5	-	-
	Class 1500	kg/lb	-	-	-	-	3.5	7.7	5.4	11.9	8.1	17.8	-	-	13.5	29.7	24.1	53.0

*End to End OMB standard

Reinforced - Lip Class 800 & 1500	SIZE	-	1/2		3/4		1		-		1 1/2		2		-	
	H	-	-	18	0.70	23	0.91	28	1.10	-	-	44	1.73	50	1.97	-
I	-	-	20.5	0.80	25.5	1.00	30.5	1.20	-	-	47	1.85	53	2.08	-	-
G	-	-	4	0.15	4.5	0.17	5	0.19	-	-	7	0.25	8	0.31	-	-
Run Size	Min.	-	1		1 1/2		2		-		3		4		-	

Dimensions and weights are subject to change without notice.
OMB reserves the rights to make modifications or changes to its production, without any prior notice.



F1-810 / F3-810 / F6-810

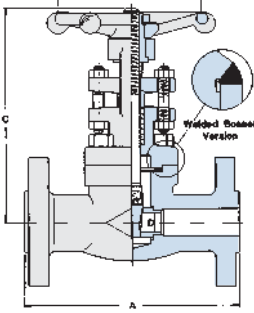

RATINGS: Carbon Steel
 Class 150: 285 p.s.i. @ 100°F - Class 300: 740 p.s.i. @ 100°F
 Class 600: 1480 p.s.i. @ 100°F

CLASS 150-300-600 BOLTED BONNET - STANDARD BORE - API602 - ISO 15761

Outside Screw & Yoke - Integral Flanged End according to ASME B16.5

STANDARD BORE		1/4		3/8		1/2		3/4		1		1 1/4		1 1/2		2	
		mm	in	mm	in	mm	in	mm	in	mm	in	mm	in	mm	in	mm	in
Class 150	F1-810 *	A	-	-	-	108	4.25	117	4.64	127	5.00	-	-	165	6.49	178	7.00
Class 300	F3-810 *	A	-	-	-	140	5.51	152	6.02	165	6.49	-	-	190	7.51	216	8.50
Class 600	F6-810 *	A	-	-	-	165	6.49	190	7.51	216	8.50	-	-	241	9.48	292	11.5
Handwheel		B	-	-	-	80	3.14	80	3.14	110	4.33	-	-	130	5.11	130	5.11
Open Center to Top	Class 150/300	C	-	-	-	170	6.69	195	7.67	203	7.99	-	-	243	9.56	262	10.3
	Class 600	C	-	-	-	148	5.82	163	6.41	178	7.00	-	-	243	9.56	262	10.3
Flow Passageway		D	-	-	-	9.6	0.38	14	0.55	18	0.70	-	-	30	1.18	37	1.45
Approx. Weight	Class 150	kg/lb	-	-	-	3.4	7.5	3.8	8.3	5.7	12.5	-	-	9.7	21.4	13.2	29.1
	Class 300	kg/lb	-	-	-	3.9	8.6	5	11.0	6.2	13.6	-	-	12	26.4	16.5	36.3
	Class 600	kg/lb	-	-	-	4	8.8	5.2	11.4	7.5	16.5	-	-	15	33.0	20.5	45.1

*End to End ANSI B16.10

F1-610 / F3-610 / F6-610

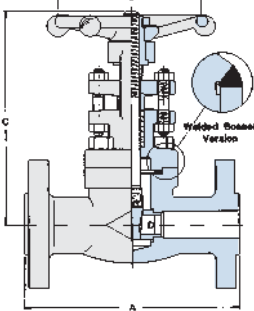

RATINGS: Carbon Steel
 Class 150: 285 p.s.i. @ 100°F - Class 300: 740 p.s.i. @ 100°F
 Class 600: 1480 p.s.i. @ 100°F

CLASS 150-300-600 BOLTED BONNET - FULL BORE - API602 - ISO 15761

Outside Screw & Yoke - Integral Flanged End according to ASME B16.5

FULL BORE		1/4		3/8		1/2		3/4		1		1 1/4		1 1/2		2	
		mm	in	mm	in	mm	in	mm	in	mm	in	mm	in	mm	in	mm	in
Class 150	F1-610 *	A	-	-	-	108	4.25	117	4.64	127	5.00	-	-	165	6.49	178	7.00
Class 300	F3-610 *	A	-	-	-	140	5.51	152	6.02	165	6.49	-	-	190	7.51	216	8.50
Class 600	F6-610 *	A	-	-	-	165	6.49	190	7.51	216	8.50	-	-	241	9.48	292	11.5
Handwheel		B	-	-	-	110	4.33	110	4.33	130	5.11	-	-	250	9.84	250	9.84
Open Center to Top	Class 150/300	C	-	-	-	170	6.69	195	7.67	210	8.26	-	-	262	10.3	327	12.8
	Class 600	C	-	-	-	244	9.60	268	10.5	310	12.2	-	-	391	15.4	430	16.9
Flow Passageway		D	-	-	-	14	0.55	18	0.70	24	0.94	-	-	37	1.45	48	1.89
Approx. Weight	Class 150	kg/lb	-	-	-	3.6	7.9	4.8	10.5	6.5	14.3	-	-	12	26.4	18	39.6
	Class 300	kg/lb	-	-	-	4.1	9.0	5.5	12.1	7.0	15.4	-	-	13	29.6	19	41.8
	Class 600	kg/lb	-	-	-	6	13.2	11	24.2	13	28.6	-	-	27	59.4	30	66.0

*End to End ANSI B16.10

Ring-Joint gasket according to ASME B16.20 - API 6A.

F9-RJ910

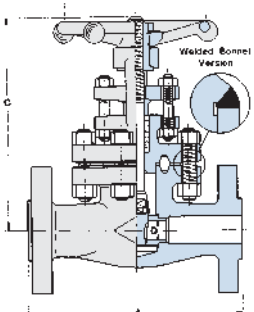

RATINGS: Carbon Steel 3705 p.s.i. @ 100°F

CLASS 1500 ROUND BOLTED BONNET RJ - FULL BORE - API602 - ISO 15761

Outside Screw & Yoke - Integral Flanged End according to ASME B16.5

FULL BORE		F9-RJ910		1/4		3/8		1/2		3/4		1		1 1/4		1 1/2		2	
		mm	in	mm	in	mm	in	mm	in	mm	in	mm	in	mm	in	mm	in	mm	in
End to End*		A	-	-	-	216	8.50	229	9.01	254	10.0	-	-	305	12.0	368	14.5		
Handwheel		B	-	-	-	110	4.33	130	5.11	130	5.11	-	-	250	9.84	300	11.8		
Open Center to Top		C	-	-	-	260	10.2	300	11.8	300	11.8	-	-	390	15.3	420	16.5		
Flow Passageway		D	-	-	-	14	0.55	18	0.70	24	0.94	-	-	37	1.45	48	1.89		
Approx. Weight		kg/lb	-	-	-	11	24.2	16	35.2	19	41.8	-	-	35	77.1	59	130.0		

*End to End ANSI B16.10

Ring-Joint gasket according to ASME B16.20 - API 6A.
 Spiral wound gasket joint available on request

F25-RJ2510

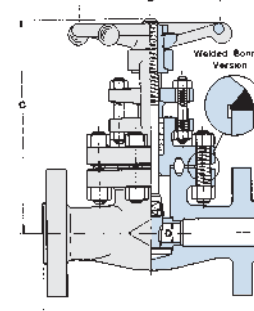

RATINGS: Carbon Steel 6170 p.s.i. @ 100°F

CLASS 2500 ROUND BOLTED BONNET RJ - FULL BORE - ASME B16.34

Outside Screw & Yoke - Integral Flanged End according to ASME B16.5

FULL BORE		F25-RJ2510		1/4		3/8		1/2		3/4		1		1 1/4		1 1/2		2	
		mm	in	mm	in	mm	in	mm	in	mm	in	mm	in	mm	in	mm	in	mm	in
End to End*		A	-	-	-	264	10.4	273	10.7	308	12.1	-	-	384	15.1	451	17.7		
Handwheel		B	-	-	-	130	5.11	130	5.11	250	9.84	-	-	300	11.8	300	11.8		
Open Center to Top		C	-	-	-	304	11.9	315	12.4	368	14.5	-	-	445	17.5	538	21.2		
Flow Passageway		D	-	-	-	14	0.55	18	0.70	24	0.94	-	-	37	1.45	37	1.45		
Approx. Weight		kg/lb	-	-	-	19	41.8	21	46.2	40	88.1	-	-	62	136.5	92	202.6		

*End to End ANSI B16.10



GATE VALVES



CLASS	JOINT	BORE	STANDARD	SCREW & YOKE	ENDS	PAGE	OMB FIG.	VOGT FIG.
800	Bolted Bonnet	SB	API 602 - ISO 15761	Outside	NPT&SW Ends	14	810	12111
800	Bolted Bonnet	FB	API 602 - ISO 15761	Outside	NPT&SW Ends	14	610	13111
800	Welded Bonnet	SB	API 602 - ISO 15761	Outside	NPT&SW Ends	14	L810	2801
800	Welded Bonnet	FB	API 602 - ISO 15761	Outside	NPT&SW Ends	14	L610	3801
800	Bolted Bonnet	SB	API 602 - ISO 15761	Inside	NPT&SW Ends	14	800	12161
800	Bolted Bonnet	FB	API 602 - ISO 15761	Inside	NPT&SW Ends	14	600	N/A*
800	Welded Bonnet	SB	API 602 - ISO 15761	Inside	NPT&SW Ends	14	L800	2811
800	Welded Bonnet	FB	API 602 - ISO 15761	Inside	NPT&SW Ends	14	L600	N/A*
1500	Bolted Bonnet	SB	API 602 - ISO 15761	Outside	NPT&SW Ends	15	R910	15111
1500	Bolted Bonnet	FB	API 602 - ISO 15761	Outside	NPT&SW Ends	15	910	16111
1500	Welded Bonnet	SB	API 602 - ISO 15761	Outside	NPT&SW Ends	15	LR910	N/A*
1500	Welded Bonnet	FB	API 602 - ISO 15761	Outside	NPT&SW Ends	15	L910	16801
1500	Ring Joint BB	FB	API 602 - ISO 15761	Outside	NPT&SW Ends	15	RJ910	1043
1500	Ring Joint BB	FB	API 602 - ISO 15761	Outside	BW Ends	15	BW9-RJ910	N/A*
2500	Ring Joint BB	FB	ASME B16.34	Outside	NPT&SW Ends	16	RJ2510	N/A*
2500	Ring Joint BB	FB	ASME B16.34	Outside	BW Ends	16	BW25-RJ2510	N/A*
2500	Welded Bonnet	FB	ASME B16.34	Outside	NPT&SW Ends	16	L2510	66703
2500	Welded Bonnet	FB	ASME B16.34	Outside	BW Ends	16	BW25-L2510	N/A*
800	Welded Bonnet	SB	API 602 - ISO 15761	Outside	M-NPTM	17	MLA-810	TT2801
800	Bolted Bonnet	SB	API 602 - ISO 15761	Outside	M-SWM	17	MA-810	TT12111
800	Welded Bonnet	SB	API 602 - ISO 15761	Outside	M-BW	17	MLW-810	CT2901
800	Bolted Bonnet	SB	API 602 - ISO 15761	Outside	M-NPTM	17	MW-810	CT12111
1500	Welded Bonnet	SB	API 602 - ISO 15761	Outside	M-NPTM	17	MLA-R910	TT15801
1500	Bolted Bonnet	SB	API 602 - ISO 15761	Outside	M-SWM	17	MA-R910	N/A*
1500	Welded Bonnet	SB	API 602 - ISO 15761	Outside	M-BW	17	MLW-R910	N/A*
1500	Bolted Bonnet	SB	API 602 - ISO 15761	Outside	M-NPTM	17	MW-R910	CT1511
150	Bolted Bonnet	SB	API 602 - ISO 15761	Outside	F Ends	18	F1-810	353
300	Bolted Bonnet	SB	API 602 - ISO 15761	Outside	F Ends	18	F3-810	363
600	Bolted Bonnet	SB	API 602 - ISO 15761	Outside	F Ends	18	F6-810	373
150	Bolted Bonnet	FB	API 602 - ISO 15761	Outside	F Ends	18	F1-610	N/A*
300	Bolted Bonnet	FB	API 602 - ISO 15761	Outside	F Ends	18	F3-610	13363
600	Bolted Bonnet	FB	API 602 - ISO 15761	Outside	F Ends	18	F6-610	13373
1500	Ring Joint BB	FB	API 602 - ISO 15761	Outside	F Ends	18	F9-RJ910	N/A*
2500	Ring Joint BB	FB	ASME B16.34	Outside	F Ends	18	F25-RJ2510	N/A*

NOTE

SB	STANDARD BORE
FB	FULL BORE
NPT&SW ENDS	THREADED AND SOCKET WELD ENDS ACCORDING TO ASME B16.11
BW	BUTT WELD ENDS ACCORDING TO ASME B16.25
BW&C	BUTT WELDED ACCORDING TO ASME B16.25 AND CLAMP ENDS ACCORDING TO MFGS STANDARDS
M-NPT MALE	EXTENDED BODY ACCORDING TO API 602 - MALE THREADED ENDS ACCORDING TO ASME B16.11
M-SWM	EXTENDED BODY ACCORDING TO API 602 - MALE SOCKET ENDS ACCORDING TO ASME B16.11
M-BW	EXTENDED BODY ACCORDING TO API 602 - BUTT WELD ENDS ACCORDING TO ASME B16.25
F	INTEGRAL FLANGED ENDS ACCORDING TO ASME B16.5
N/A*	FIGURE VALVE IS NOT INCLUDED IN THE BFE OR VOGT CATALOG



IMPORTANT: USE CAUTION WITH VOGT FIG. INDICATED ABOVE AS THEY ARE INCLUSIVE OF VALVES MATERIALS.



Globe valves are unidirectional and closing-down valves in which the closure member is moved squarely on and off the seat and are designed to maintain the pressure flowing under the disc. In this way, the opening of the port is directly proportional to the travel of the disc.

This proportional relationship is ideally suited for applications that require flowrate regulation.

In order to increase precision in the regulation, the disc element is available in three different configurations: parabolic, needle and v-port. Furthermore the short-travel of the disc between the open and closed positions makes these valves ideally suited for on-off duties when they must be opened and closed frequently.

CONSTRUCTION

ISO15761 2nd ed., 2002
API602 10th.ed, 2015
ASME B16.34 2013 ed.

T-body, bolted or
welded bonnet

size 1/2"-4"

Closed Die Forging

Full and Standard Bore

150, 300, 600, 800,
1500, 2500, 4500

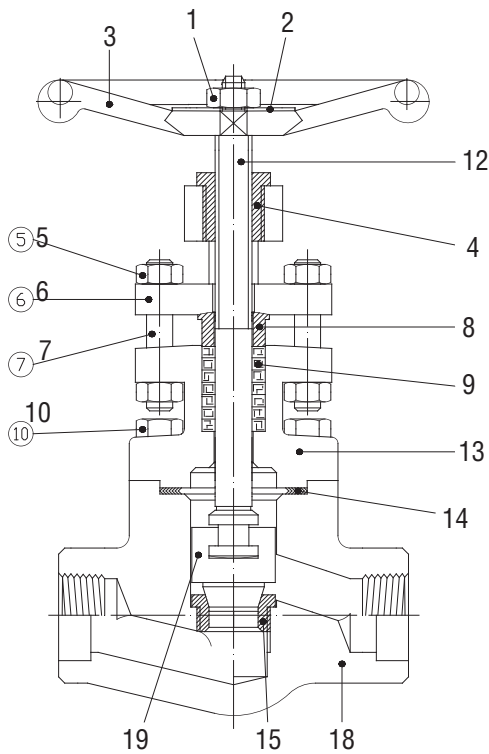

1	WHEELNUT	Austenitic ductile iron, 13Cr steel, or copper alloy having a melting point above 955 °C (1750 °F).
2	NAMEPLATE	A corrosion resistant metal.
3	HANDWHEEL	Malleable iron, carbon steel, or ductile iron.
4	YOKE NUT	Carbon steel, stainless steel or similar material composition as the bonnet.
5	GLAND NUT	Bolting materials of a Type 300 or Type 400 series stainless steel. Also, material at least equal to either ASTM A307-Grade B may be used for yoke bolting.
6	GLAND FLANGE	Steel.
7	GLAND STUD	Unless other materials are agreed between the purchaser and manufacturer, refer to the recommended bolting material in Annex G of API 602.
8	GLAND	Material with a melting point above 955 °C (1750 °F).
9	PACKING (*)	Non-asbestos material suitable for steam and petroleum fluids over a temperature range of -29 °C to 540 °C (-20 °F to 1000 °F) and containing a corrosion inhibitor.
10	BOLTS	Unless other materials are agreed between the purchaser and manufacturer, refer to the recommended bolting material in Annex G of API 602.
12	STEM	Refer to API Standard 602, Table 12.
13	BONNET	A forging, forged bar or casting material as selected from ASME B16.34, Group 1, 2 or Group 3 and listed in Table 1 of API 602.
14	GASKET	Refer to API Standard 602, (see 5.5.3).
15	SEAT	The base material of the seat ring, when used, shall be of a nominal material composition equal to the body material or the stem material. Refer to API 602 (see 6.1.4).
18	BODY	A forging, forged bar or casting material as selected from ASME B16.34, Group 1, 2 or Group 3 and listed in Table 1 of API 602.
19	DISC	The base material of the wedge/disc shall be of a nominal material composition equal to the body material or the stem material. Refer to API 602 (see 6.1.4).

DESCRIPTION	A105N/F6	A105N/F6HFS	LF2/F316	F11/F6HFS	F304-304	F316-316
WHEELNUT	Galvanized AVP	Galvanized AVP	Galvanized AVP	Galvanized AVP	303	303
NAMEPLATE	Aluminium	Aluminium	Aluminium	Aluminium	Aluminium	Aluminium
HANDWHEEL	Carbon Steel	Carbon Steel	Carbon Steel	Carbon Steel	Carbon Steel Black Epoxy	Carbon Steel Black Epoxy
YOKE NUT	416	416	416	416	416	416
GLAND NUT	2H	2H	Gr.8M	Gr.8M	Gr.8	Gr.8
GLAND FLANGE	A105	A105	LF2	F6a Cl.2	304/304L	316
GLAND STUD	F6a Cl.2 (410)	F6a Cl.2 (410)	B8M CL.1	B8M CL.1	B8 CL.1	B8 CL.1
GLAND	316	316	316	316	316	316
PACKING (*)	Graphite	Graphite	Graphite	Graphite	Graphite	Graphite
BOLTS	B7	B7	L7	B16	B8 CL.1	B8 CL.1
STEM	F6a Cl.2 (410)	F6a Cl.2 (410)	316/316L	F6a Cl.2 (410)	304/304L	316
BONNET	A105N	A105N	LF2	F11 Cl.2	304/304L	316/316L
GASKET	316+Graphite	316+Graphite	316+Graphite	316+Graphite	316+Graphite	316+Graphite
SEAT	F6a Cl.2 (410)	410 HF	316/316L	410 HF	304/304L	316
WEDGE	F6a Cl.2 (410)	F6a Cl.2 (410)	316/316L	F6a Cl.2 (410)	304/304L	316
BODY	A105N	A105N	LF2	F11 Cl.2	304/304L	316/316L



830/630

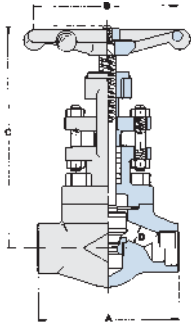

RATINGS: Carbon Steel 1975 p.s.i. @ 100°F

CLASS 800 BOLTED BONNET - STANDARD BORE TO API602/ISO 15761 - FULL BORE - BS 5352

Outside Screw & Yoke - Threaded and Socket Weld Ends

STANDARD BORE	830	-		1/2		3/4		1		1 1/4		1 1/2		2		-	
FULL BORE	630	1/4		3/8		1/2		3/4		1		1 1/4		1 1/2		2	
		mm	in	mm	in	mm	in	mm	in	mm	in	mm	in	mm	in	mm	in
End to End	A	80	3.14	80	3.14	90	3.54	110	4.33	127	5.00	155	6.10	170	6.69	210	8.26
Handwheel	B	80	3.14	80	3.14	80	3.14	110	4.33	130	5.11	130	5.11	180	7.08	180	7.08
Open Center to Top	C	148	5.82	148	5.82	165	6.49	180	7.08	213	8.38	248	9.76	257	10.1	370	14.5
Flow Passageway	D	7	0.28	9	0.35	13	0.51	17.5	0.69	23	0.89	29.5	1.16	35	1.37	45.5	1.79
Approx. Weight	kg/lb	1.7	3.7	1.7	3.7	2.3	5.0	3.6	7.9	5.5	12.1	7.5	16.5	11.6	25.5	22.0	48.5

L830/L630

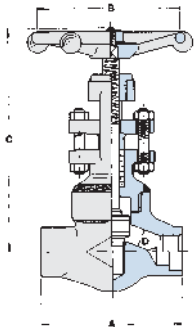

RATINGS: Carbon Steel 1975 p.s.i. @ 100°F

CLASS 800 WELDED BONNET - STANDARD BORE TO API602/ISO 15761 - FULL BORE - BS 5352

Outside Screw & Yoke - Threaded and Socket Weld Ends

STANDARD BORE	L830	-		1/2		3/4		1		1 1/4		1 1/2		2		-	
FULL BORE	L630	1/4		3/8		1/2		3/4		1		1 1/4		1 1/2		2	
		mm	in	mm	in	mm	in	mm	in	mm	in	mm	in	mm	in	mm	in
End to End	A	80	3.14	80	3.14	90	3.54	110	4.33	127	5.00	155	6.10	170	6.69	210	8.26
Handwheel	B	80	3.14	80	3.14	80	3.14	110	4.33	130	5.11	130	5.11	180	7.08	180	7.08
Open Center to Top	C	148	5.82	148	5.82	165	6.49	180	7.08	213	8.38	248	9.76	257	10.1	370	14.5
Flow Passageway	D	7	0.28	9	0.35	13	0.51	17.5	0.69	23	0.89	29.5	1.16	35	1.37	45.5	1.79
Approx. Weight	kg/lb	1.7	3.7	1.7	3.7	2.3	5.0	3.6	7.9	5.5	12.1	7.3	16	10.5	23.1	17.5	38.5

L820/L620

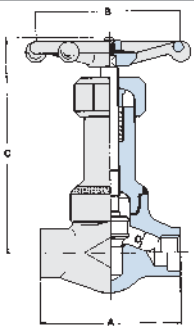

RATINGS: Carbon Steel 1975 p.s.i. @ 100°F

CLASS 800 WELDED BONNET - STANDARD BORE TO API602/ISO 15761 - FULL BORE - BS 5352

Inside Screw - Threaded and Socket Weld Ends

STANDARD BORE	L820	-		1/2		3/4		1		1 1/4		1 1/2		2		-	
FULL BORE	L620	1/4		3/8		1/2		3/4		1		1 1/4		1 1/2		2	
		mm	in	mm	in	mm	in	mm	in	mm	in	mm	in	mm	in	mm	in
End to End	A	80	3.14	80	3.14	90	3.54	110	4.33	127	5.00	155	6.10	170	6.69	210	8.26
Handwheel	B	80	3.14	80	3.14	80	3.14	110	4.33	130	5.11	130	5.11	180	7.08	180	7.08
Open Center to Top	C	148	5.86	148	5.86	175	6.88	212	8.34	235	9.25	287	11.3	327	12.9	380	15.0
Flow Passageway	D	7	0.28	9	0.35	13	0.51	17.5	0.69	23	0.89	29.5	1.16	35	1.37	45.5	1.79
Approx. Weight	kg/lb	1.5	3.3	1.5	3.3	2.0	4.4	3.7	8.1	5.5	12.1	7.3	16	10.5	23.1	17.5	38.5

R930/930

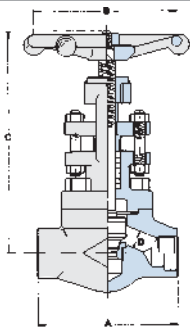

RATINGS: Carbon Steel 3705 p.s.i. @ 100°F

CLASS 1500 BOLTED BONNET STANDARD BORE TO API602/ISO 15761 - FULL BORE - BS 5352

Outside Screw & Yoke - Threaded and Socket Weld Ends

STANDARD BORE	R930	-		1/2		3/4		1		1 1/4		1 1/2		2		-	
FULL BORE	930	1/4		3/8		1/2		3/4		1		1 1/4		1 1/2		2	
		mm	in	mm	in	mm	in	mm	in	mm	in	mm	in	mm	in	mm	in
End to End	A	90	3.54	90	3.54	110	4.33	127	5.00	155	6.10	170	6.69	210	8.26	210	8.26
Handwheel	B	80	3.14	80	3.14	110	4.33	130	5.11	130	5.11	180	7.08	180	7.08	180	7.08
Open Center to Top	C	160	6.29	160	6.29	175	6.88	210	8.26	244	9.60	250	9.84	370	14.5	375	14.7
Flow Passageway	D	7	0.28	9	0.35	13	0.51	17	0.67	21	0.83	28	1.10	33	1.30	37.5	1.48
Approx. Weight	kg/lb	2.2	4.8	2.2	4.8	3.9	8.5	6	13.2	8	17.6	12	26.4	23.5	51.7	23	50.6



LR930/L930

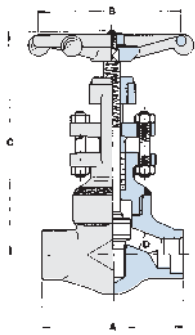

RATINGS: Carbon Steel 3705 p.s.i. @ 100°F

CLASS 1500 WELDED BONNET STANDARD BORE TO API602/ISO 15761 - FULL BORE - BS 5352

Outside Screw & Yoke - Threaded and Socket Weld Ends

STANDARD BORE	LR930	-		1/2		3/4		1		1 1/4		1 1/2		2		-	
FULL BORE	L930	1/4		3/8		1/2		3/4		1		1 1/4		1 1/2		2	
		mm	in	mm	in	mm	in	mm	in	mm	in	mm	in	mm	in	mm	in
End to End	A	90	3.54	90	3.54	110	4.33	127	5.00	155	6.10	170	6.69	210	8.26	210	8.26
Handwheel	B	80	3.14	80	3.14	110	4.33	130	5.11	130	5.11	180	7.08	180	7.08	180	7.08
Open Center to Top	C	160	6.29	160	6.29	175	6.88	210	8.26	244	9.60	250	9.84	370	14.5	375	14.7
Flow Passageway	D	7	0.28	9	0.35	13	0.51	17	0.67	21	0.83	28	1.10	33	1.30	37.5	1.48
Approx. Weight	kg/lb	2.2	4.8	2.2	4.8	3.9	8.5	6	13.2	8	17.6	12	26.4	19	41.8	18.5	40.7

RJ930

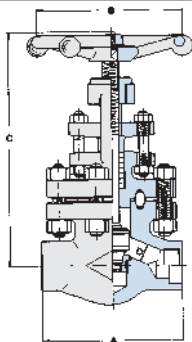

RATINGS: Carbon Steel 3705 p.s.i. @ 100°F

CLASS 1500 ROUND BOLTED BONNET RJ - FULL BORE - BS 5352

Outside Screw & Yoke - Threaded and Socket Weld Ends

FULL BORE	RJ930	1/4		3/8		1/2		3/4		1		1 1/4		1 1/2		2	
		mm	in	mm	in	mm	in	mm	in	mm	in	mm	in	mm	in	mm	in
End to End	A	-	-	-	-	110	4.33	150	5.90	150	5.90	-	-	210	8.26	235	9.25
Handwheel	B	-	-	-	-	110	4.33	130	5.11	130	5.11	-	-	180	7.08	250	9.84
Open Center to Top	C	-	-	-	-	235	9.25	265	10.4	310	12.2	-	-	370	14.5	435	17.1
Flow Passageway	D	-	-	-	-	13	0.51	17	0.67	21	0.83	-	-	33	1.30	37.5	1.48
Approx. Weight	kg/lb	-	-	-	-	5.1	11.2	11	24.2	12.1	26.6	-	-	22	48.4	37	81.5

RJ2530

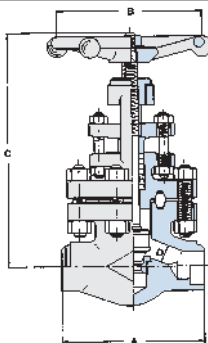

RATINGS: Carbon Steel 6170 p.s.i. @ 100°F

CLASS 2500 ROUND BOLTED BONNET RJ - FULL BORE - ASME B16.34

Outside Screw & Yoke - Socket and Butt Weld Ends

FULL BORE	RJ2530	1/4		3/8		1/2		3/4		1		1 1/4		1 1/2		2	
		mm	in	mm	in	mm	in	mm	in	mm	in	mm	in	mm	in	mm	in
End to End	A	-	-	-	-	150	5.90	150	5.90	210	8.26	-	-	235	9.25	235	9.25
Handwheel	B	-	-	-	-	130	5.11	130	5.11	250	9.84	-	-	300	11.8	300	11.8
Open Center to Top	C	-	-	-	-	265	10.4	254	10.4	360	14.1	-	-	430	16.9	435	17.1
Flow Passageway	D	-	-	-	-	13	0.51	17	0.67	21	0.83	-	-	33	1.30	35	1.37
Approx. Weight	kg/lb	-	-	-	-	11	24.2	11.3	24.8	22.4	49.3	-	-	38	83.7	38	83.7

Spiral wound gasket joint available on request.

Ring-Joint gasket according to ASME B16.20 - API 6A.

L2530

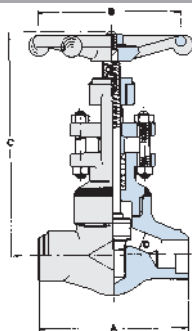

RATINGS: Carbon Steel 6170 p.s.i. @ 100°F

CLASS 2500 WELDED BONNET RJ - FULL BORE - ASME B16.34

Outside Screw & Yoke - Socket and Butt Weld Ends

FULL BORE	L2530	1/4		3/8		1/2		3/4		1		1 1/4		1 1/2		2	
		mm	in	mm	in	mm	in	mm	in	mm	in	mm	in	mm	in	mm	in
End to End	A	-	-	-	-	127	5.00	155	6.10	170	6.69	-	-	235	9.25	235	9.25
Handwheel	B	-	-	-	-	130	5.11	130	5.11	130	5.11	-	-	300	11.8	300	11.8
Open Center to Top	C	-	-	-	-	237	9.33	242	9.52	256	10.1	-	-	430	16.9	435	17.1
Flow Passageway	D	-	-	-	-	13	0.51	17	0.67	21	0.83	-	-	33	1.30	35	1.37
Approx. Weight	kg/lb	-	-	-	-	6.5	14.3	8.5	18.7	12.5	27.5	-	-	26	57.2	25.5	56.1

Dimensions and weights are subject to change without notice.

OMB reserves the rights to make modifications or changes to its production, without any prior notice.



RJ4530

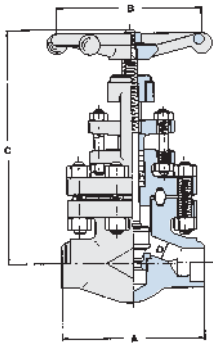

RATINGS: Carbon Steel 11110 p.s.i. @ 100°F

CLASS 4500 ROUND BOLTED BONNET RJ - FULL BORE - ASME B16.34

Outside Screw & Yoke - Socket and Butt Weld Ends

FULL BORE	RJ4530	-		1/2		3/4		1		1 1/4		1 1/2		2		-	
		mm	in	mm	in	mm	in	mm	in	mm	in	mm	in	mm	in	mm	in
End to End	A	-	-	-	-	210	8.26	210	8.26	235	9.25	-	-	235	9.25	-	-
Handwheel	B	-	-	-	-	250	9.84	250	9.84	300	11.8	-	-	300	11.8	-	-
Open Center to Top	C	-	-	-	-	345	13.5	350	13.7	420	16.5	-	-	430	16.9	-	-
Flow Passageway	D	-	-	-	-	9	0.35	11	0.43	14	0.55	-	-	28	1.10	-	-
Approx. Weight	kg/lb	-	-	-	-	23	50.6	23	50.6	38.5	84.8	-	-	38.5	84.8	-	-

2" on request

Ring-Joint gasket according to ASME B16.20 - API 6A.

L4530

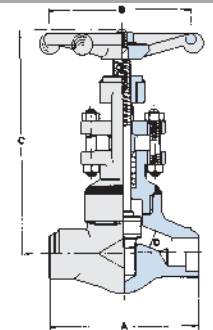

RATINGS: Carbon Steel 11110 p.s.i. @ 100°F

CLASS 4500 WELDED BONNET - FULL BORE - ASME B16.34

Outside Screw & Yoke - Socket and Butt Weld Ends

FULL BORE	L4530	1/4		3/8		1/2		3/4		1		1 1/4		1 1/2		2	
		mm	in	mm	in	mm	in	mm	in	mm	in	mm	in	mm	in	mm	in
End to End	A	-	-	-	-	155	6.10	170	6.69	210	8.26	-	-	235	9.25	-	-
Handwheel	B	-	-	-	-	180	7.08	250	9.84	250	9.84	-	-	300	11.8	-	-
Open Center to Top	C	-	-	-	-	240	9.44	250	11.2	350	13.7	-	-	410	16.1	-	-
Flow Passageway	D	-	-	-	-	11	0.43	11	0.43	14	0.55	-	-	28	1.10	-	-
Approx. Weight	kg/lb	-	-	-	-	9	19.8	13	28.6	24.5	53.9	-	-	28	61.7	-	-

2" on request

BW45-RJ4530

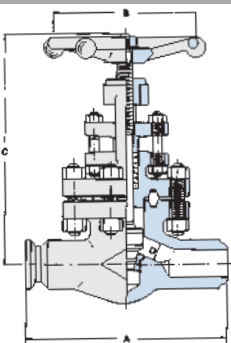

RATINGS: Carbon Steel 11110 p.s.i. @ 100°F

CLASS 4500 ROUND BOLTED BONNET RJ - FULL BORE - ASME B16.34

Outside Screw & Yoke - Clamp and Butt Weld Ends

FULL BORE	RJ4530-BW	1/4		3/8		1/2		3/4		1		1 1/4		1 1/2		2	
		mm	in	mm	in	mm	in	mm	in	mm	in	mm	in	mm	in	mm	in
End to End	A	-	-	-	-	260	10.2	300	11.8	370	14.5	-	-	370	14.5	-	-
Handwheel	B	-	-	-	-	180	7.08	250	9.84	300	11.8	-	-	300	11.8	-	-
Open Center to Top	C	-	-	-	-	280	11.0	360	14.1	456	17.9	-	-	466	18.3	-	-
Flow Passageway	D	-	-	-	-	11	0.43	11	0.43	14	0.55	-	-	28	1.10	-	-
Approx. Weight	kg/lb	-	-	-	-	18	39.6	34	74.9	50	110.1	-	-	50	110.1	-	-

2" on request

(*) End to end dimension according to ANSI B16.10

BW45-L4530

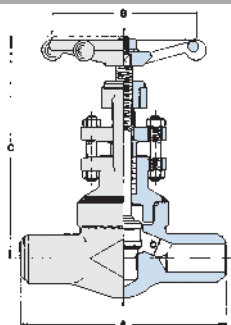

RATINGS: Carbon Steel 11110 p.s.i. @ 100°F

CLASS 4500 WELDED BONNET - FULL BORE - ASME B16.34

Outside Screw & Yoke - Clamp and Butt Weld Ends

FULL BORE	L4530-BW	1/4		3/8		1/2		3/4		1		1 1/4		1 1/2		2	
		mm	in	mm	in	mm	in	mm	in	mm	in	mm	in	mm	in	mm	in
End to End	A	-	-	-	-	260	10.2	300	11.8	370	14.5	-	-	370	14.5	-	-
Handwheel	B	-	-	-	-	180	7.08	250	9.84	300	11.8	-	-	300	11.8	-	-
Open Center to Top	C	-	-	-	-	280	11.0	360	14.1	456	17.9	-	-	466	18.3	-	-
Flow Passageway	D	-	-	-	-	11	0.43	11	0.43	14	0.55	-	-	28	1.10	-	-
Approx. Weight	kg/lb	-	-	-	-	17	37.4	32	70.5	46	101.3	-	-	46	101.3	-	-

2" on request

(*) End to end dimension according to ANSI B16.10

Dimensions and weights are subject to change without notice.

OMB reserves the rights to make modifications or changes to its production, without any prior notice.



F1-830/ F3-830/ F6-830

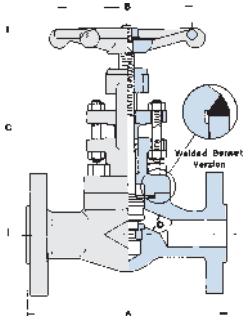

RATINGS: Carbon Steel
 Class 150: 285 p.s.i. @ 100°F - Class 300: 740 p.s.i. @ 100°F
 Class 600: 1480 p.s.i. @ 100°F

CLASS 150-300-600 BOLTED BONNET - STANDARD BORE - API602/ISO15761

Outside Screw & Yoke - Integral Flanged End according to ASME B16.5

STANDARD BORE		1/4		3/8		1/2		3/4		1		1 1/4		1 1/2		2	
		mm	in	mm	in	mm	in	mm	in	mm	in	mm	in	mm	in	mm	in
Class 150	F1-830	A	-	-	-	108	4.25	117	4.64	127	5.00	-	-	165	6.49	178	7.00
Class 300	F3-830	A	-	-	-	152	6.02	178	7.00	203	7.99	-	-	229	9.01	267	10.5
Class 600	F6-830	A	-	-	-	165	6.49	190	7.51	216	8.50	-	-	241	9.48	292	11.5
Handwheel		B	-	-	-	80	3.14	80	3.14	110	4.33	-	-	130	5.11	180	7.08
Center to Top Open	Class 150/300	C	-	-	-	148	5.82	165	6.49	180	7.08	-	-	248	9.76	257	10.1
	Class 600	C	-	-	-	170	6.69	197	7.75	205	8.07	-	-	248	9.76	257	10.1
Flow Passageway		D	-	-	-	9	0.35	13	0.51	17.5	0.69	-	-	29.5	1.16	35	1.37
Approx. Weight	Class 150	kg/lb	-	-	-	3.4	7.5	4	8.8	5.7	12.5	-	-	10	22.0	17.0	37.4
	Class 300	kg/lb	-	-	-	4	8.8	5	11.0	7.3	16.1	-	-	14	30.8	20.5	45.1
	Class 600	kg/lb	-	-	-	4.5	9.9	5.5	12.1	7.6	16.7	-	-	15	33.0	21	46.2

End to end dimension according to ANSI B16.10

F1-630/ F3-630/ F6-630

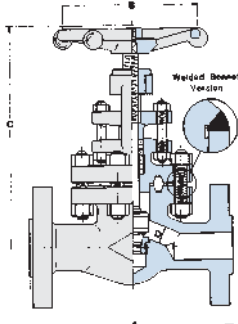

RATINGS: Carbon Steel
 Class 150: 285 p.s.i. @ 100°F - Class 300: 740 p.s.i. @ 100°F
 Class 600: 1480 p.s.i. @ 100°F

CLASS 150-300-600 BOLTED BONNET - FULL BORE - BS 5352

Outside Screw & Yoke - Integral Flanged End according to ASME B16.5

FULL BORE		1/4		3/8		1/2		3/4		1		1 1/4		1 1/2		2	
		mm	in	mm	in	mm	in	mm	in	mm	in	mm	in	mm	in	mm	in
Class 150	F1-630	A	-	-	-	108	4.25	117	4.64	127	5.00	-	-	165	6.49	203	7.99
Class 300	F3-630	A	-	-	-	152	6.02	178	7.00	203	7.99	-	-	229	9.01	267	10.5
Class 600	F6-630	A	-	-	-	165	6.49	190	7.51	216	8.50	-	-	241	9.48	292	11.5
Handwheel		B	-	-	-	110	4.33	110	4.33	130	5.11	-	-	250	9.84	250	9.84
Open Center to Top	Class 300/600	C	-	-	-	246	9.64	273	10.7	295	11.6	-	-	410	16.1	440	17.3
	Class 150	C	-	-	-	170	6.69	197	7.75	205	8.07	-	-	285	11.02	320	12.6
Flow Passageway		D	-	-	-	13	0.51	17.5	0.69	22.5	0.89	-	-	35	1.37	45.5	1.79
Approx. Weight	Class 150	kg/lb	-	-	-	4.2	9.2	5.5	12.1	7.5	16.5	-	-	13.5	29.7	21	46.2
	Class 300	kg/lb	-	-	-	5.8	12.8	10.8	23.8	12.8	28.2	-	-	26.5	58.4	29	63.9
	Class 600	kg/lb	-	-	-	6	13.2	10	22.0	14.5	32.0	-	-	27	59.4	30	66.0

End to end dimension according to ANSI B16.10
 Spiral wound gasket joint for #150

Ring-Joint gasket according to ASME B16.20 - API 6A
 (*)End to end dimension BW on request Fig. N. BW 1-630/BW 6-630

F9-RJ930/ F25-RJ2530

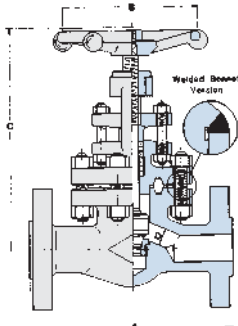

RATINGS: Carbon Steel
 Class 1500: 3705 p.s.i. @ 100°F - Class 2500: 6170 p.s.i. @ 100°F

CLASS 1500-2500 ROUND BOLTED BONNET RJ - FULL BORE - BS 5352 - ASME B16.34

Outside Screw & Yoke - Integral Flanged End according to ASME B16.5

FULL BORE		1/4		3/8		1/2		3/4		1		1 1/4		1 1/2		2	
		mm	in	mm	in	mm	in	mm	in	mm	in	mm	in	mm	in	mm	in
Class 1500	F9-RJ930	A	-	-	-	216	8.50	229	9.01	254	10.0	-	-	305	12.0	368	14.5
Class 2500	F25-RJ2530	A	-	-	-	264	10.4	273	10.7	308	12.1	-	-	384	15.1	451	17.7
Handwheel	Class 1500	B	-	-	-	110	4.33	130	5.11	130	5.11	-	-	250	9.84	300	11.8
	Class 2500	B	-	-	-	130	5.11	130	5.11	250	9.84	-	-	300	11.8	300	11.8
Open Center to Top	Class 1500	C	-	-	-	260	10.2	300	11.8	300	11.8	-	-	390	15.3	420	16.5
	Class 2500	C	-	-	-	332	13.0	332	13.0	370	14.5	-	-	435	17.1	570	22.4
Flow Passageway	Class 1500	D	-	-	-	13	0.51	17	0.67	21	0.83	-	-	33	1.30	37.5	1.48
	Class 2500	D	-	-	-	11	0.43	17	0.67	21	0.83	-	-	33	1.30	37.5	1.48
Approx. Weight	Class 1500	kg/lb	-	-	-	11	24.2	16	35.2	19.5	42.9	-	-	34	74.8	61	134.3
	Class 2500	kg/lb	-	-	-	19.5	42.9	21.5	47.3	42	92.5	-	-	65	143.2	95	209.2

End to end dimension according to ANSI B16.10
 For class 1500 spiral wound gasket joint available on request

Ring-Joint gasket according to ASME B16.20 - API 6A
 (*)End to end dimension BW on request Fig. N. BW 9-RJ930/BW 25-RJ2530



YL630

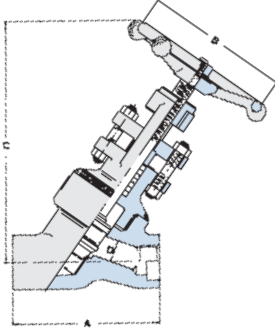

RATINGS: Carbon Steel 1975 p.s.i. @ 100°F

CLASS 800 WELDED BONNET - FULL BORE - ASME B16.34

Outside Screw & Yoke - Threaded and Socket Weld Ends

FULL BORE	YL630	-		1/2		3/4		1		1 1/4		1 1/2		2		-	
		mm	in	mm	in	mm	in	mm	in	mm	in	mm	in	mm	in	mm	in
End to End	A	110	4.33	100	4.33	110	4.33	110	4.33	142	5.59	142	5.59	170	6.69	180	7.08
Handwheel	B	80	3.14	80	3.14	80	3.14	110	4.33	130	5.11	130	5.11	180	7.08	180	7.08
Open Center to Top	C	155	6.10	155	6.10	155	6.10	175	6.88	220	8.66	240	9.44	280	11.02	350	13.78
Flow Passageway	D	7	0.27	9	0.35	13	0.51	17.5	0.68	23	0.88	29.5	1.16	35	1.37	45.5	1.79
Approx. Weight	kg/lb	1.5	3.3	1.5	3.3	1.5	3.3	2	4.4	4.2	9.2	5	11	9	19.8	13	28.6

YL930

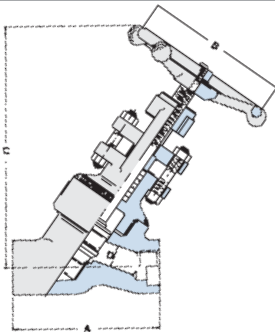

RATINGS: Carbon Steel
Class 1500: 3705 p.s.i. @ 100°F - Class 1690: 4198 p.s.i. @ 100°F

CLASS 1500-1690 WELDED BONNET - FULL BORE - ASME B16.34

Outside Screw & Yoke - Threaded and Socket Weld Ends

FULL BORE	YL930	1/4		3/8		1/2		3/4		1		1 1/4		1 1/2		2	
		mm	in	mm	in	mm	in	mm	in	mm	in	mm	in	mm	in	mm	in
End to End	A	110	4.33	110	4.33	110	4.33	142	5.59	142	5.59	170	6.69	170	6.69	180	7.08
Handwheel	B	110	4.33	110	4.33	110	4.33	130	5.11	130	5.11	180	7.08	180	7.08	180	7.08
Open Center to Top	C	180	7.08	180	7.08	170	7.08	240	9.44	250	9.84	280	11.02	380	14.96	420	16.53
Flow Passageway	D	7	0.27	9	0.35	11	0.43	15	0.59	19.5	0.76	27.5	1.08	31.5	1.24	39	1.53
Approx. Weight	kg/lb	2	4.4	2	4.4	2	4.4	4.2	9.2	5.2	11.4	9	20.9	10.5	23.1	13.5	29.8

YL2530

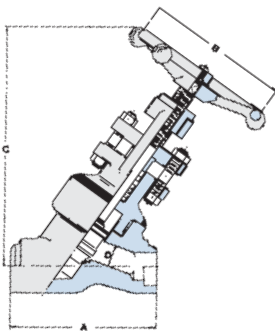

RATINGS: Carbon Steel
Class 2500: 6170 p.s.i. @ 100°F - *Class 2680: 6664 p.s.i. @ 100°F

CLASS 2500-2680 WELDED BONNET - FULL BORE - ASME B16.34

Outside Screw & Yoke - Socket and Butt Weld Ends

FULL BORE	YL2530	1/4		3/8		1/2		3/4		1		1 1/4		1 1/2		2	
		mm	in	mm	in	mm	in	mm	in	mm	in	mm	in	mm	in	mm	in
End to End	A	142	5.59	142	5.59	142	5.59	142	5.59	170	6.69	170	6.69	180	7.08	225	8.86
Handwheel	B	130	5.11	130	5.11	130	5.11	130	5.11	180	7.08	180	7.08	180	7.08	300	11.8
Open Center to Top	C	280	11.02	280	11.02	280	11.02	280	11.02	360	14.1	370	14.56	420	16.53	540	21.2
Flow Passageway	D	7	0.27	9	0.35	11	0.43	15	0.59	19.5	0.76	27.5	1.08	31.5	1.24	39	1.53
Approx. Weight	kg/lb	4.5	9.9	4.5	9.9	4.5	9.9	7.1	15.6	7.6	16.7	9.8	21.5	17.1	37.8	36	79.5

YL4 530

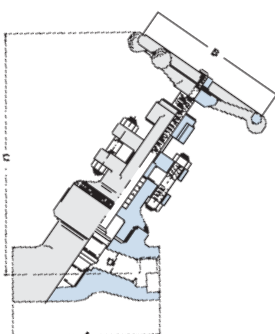

RATINGS: Carbon Steel - 11110 psi @ 100°F

CLASS 4500 WELDED BONNET - FULL BORE - ASME B16.34

Outside Screw & Yoke - Socket and Butt Weld Ends

FULL BORE	YL4530	1/4		3/8		1/2		3/4		1		1 1/4		1 1/2		2	
		mm	in	mm	in	mm	in	mm	in	mm	in	mm	in	mm	in	mm	in
End to End	A	170	6.69	170	6.69	170	6.69	170	6.69	170	6.69	-	-	225	8.86	225	8.86
Handwheel	B	180	7.09	180	7.09	180	7.09	180	7.09	180	7.09	-	-	400	15.75	400	15.75
Open Center to Top	C	350	13.78	350	13.78	350	13.78	350	13.78	380	14.96	-	-	453	17.83	453	17.83
Flow Passageway	D	7	0.28	9	0.35	11	0.43	11	0.43	15	0.59	-	-	26	1.02	28	1.10
Approx. Weight	kg/lb	9.48	20.9	9.48	20.9	9.48	20.9	9.3	20.4	10.4	22.9	-	-	33.6	73.92	35.6	78.3



Y-PATTERN GLOBE VALVES



YB630

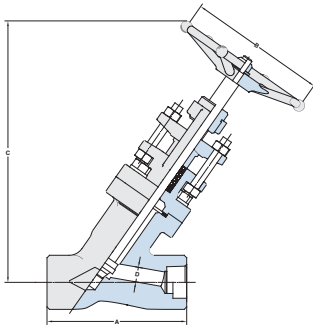

RATINGS: Carbon Steel - 1975 psi @100°F

CLASS 800 BOLTED BONNET - FULL BORE - ASME B16.34

Outside Screw & Yoke - Threaded and Socket Weld Ends

FULL BORE	YB630	1/4		3/8		1/2		3/4		1		1 1/4		1 1/2		2	
		mm	in	mm	in	mm	in	mm	in	mm	in	mm	in	mm	in	mm	in
End to End	A	110	4.33	110	4.33	110	4.33	110	4.33	142	5.59	142	5.59	170	6.69	180	7.09
Handwheel	B	80	3.15	80	3.15	80	3.15	110	4.33	130	5.12	130	5.12	180	7.09	180	7.09
Open Center to Top	C	205	8.07	205	8.07	205	8.07	215	8.46	270	10.63	300	11.81	330	12.99	400	15.75
Flow Passageway	D	7	0.28	9	0.35	13	0.51	17.5	0.69	22.5	0.89	29.5	1.16	35	1.38	45.5	1.79
Approx. Weight	kg/lb	2.6	5.7	2.6	5.7	2.6	5.7	2.7	5.9	6.3	13.9	7	15.4	12	26.4	17.3	38.1

YB930

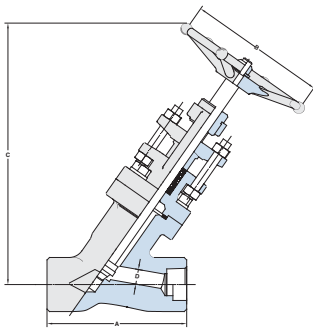

RATINGS: Carbon Steel
Class 1500 - 3705 psi @100°F - *Class 1690 - 4198 psi @100°F

CLASS 1500-1690 BOLTED BONNET - FULL BORE - ASME B16.34

Outside Screw & Yoke - Threaded and Socket Weld Ends

FULL BORE	YB930	1/4		3/8		1/2		3/4		1		1 1/4		1 1/2		2	
		mm	in	mm	in	mm	in	mm	in	mm	in	mm	in	mm	in	mm	in
End to End	A	110	4.33	110	4.33	110	4.33	142	5.59	142	5.59	170	6.69	180	7.09	180	7.09
Handwheel	B	110	4.33	110	4.33	110	4.33	130	5.12	130	5.12	180	7.09	180	7.09	180	7.09
Open Center to Top	C	215	8.46	215	8.46	215	8.46	270	10.63	280	11.02	315	12.40	375	14.76	460	18.11
Flow Passageway	D	7	0.28	9	0.35	11	0.43	15	0.59	19.5	0.77	27.5	1.08	31.5	1.24	39	1.54
Approx. Weight	kg/lb	3.5	7.7	3.5	7.7	3.5	7.7	6.5	14.3	7	15.4	10.5	23.1	19.3	42.46	24.8	54.6

YB2530

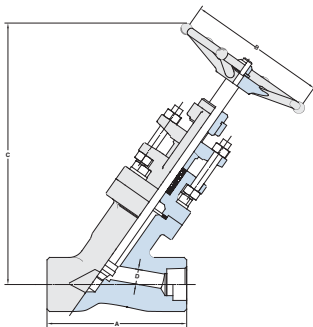

RATINGS: Carbon Steel
Class 2500 - 6170 psi @100°F - *Class 2680 - 6664 psi @100°F

CLASS 2500-2680 BOLTED BONNET - FULL BORE - ASME B16.34 - Outside Screw & Yoke

Threaded, Socket Weld or Butt Weld Ends

FULL BORE	YB2530	1/4		3/8		1/2		3/4		1		1 1/4		1 1/2		2	
		mm	in	mm	in	mm	in	mm	in	mm	in	mm	in	mm	in	mm	in
End to End	A	142	5.59	142	5.59	142	5.59	170	6.69	170	6.69	180	7.09	180	7.09	225	8.86
Handwheel	B	130	5.12	130	5.12	130	5.12	130	5.12	180	7.09	180	7.09	180	7.09	300	11.81
Open Center to Top	C	280	11.02	280	11.02	280	11.02	280	11.02	330	12.99	375	14.76	460	18.11	620	24.41
Flow Passageway	D	7	0.28	9	0.35	11	0.43	15	0.59	19.5	0.77	27.5	1.08	31.5	1.24	39	1.54
Approx. Weight	kg/lb	5.7	12.5	5.7	12.5	5.7	12.5	12.5	27.5	13.5	29.7	19.3	42.46	24.8	54.56	41.3	90.9



BW6-YL630

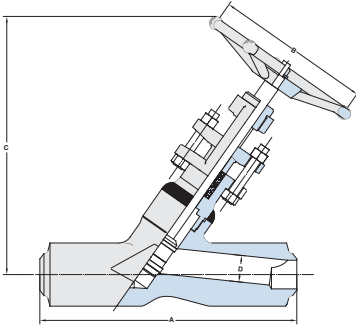

RATINGS: Carbon Steel - 1975 psi @100°F

CLASS 600 WELDED BONNET - FULL BORE - ASME B16.34

Outside Screw & Yoke - Butt Weld Ends

FULL BORE	BW6-YL630	-		1/2		3/4		1		1 1/4		1 1/2		2		-	
		mm	in	mm	in	mm	in	mm	in	mm	in	mm	in	mm	in	mm	in
End to End	A	216	8.50	216	8.50	216	8.50	216	8.50	273	10.75	273	10.75	308	12.13	384	15.12
Handwheel	B	80	3.15	80	3.15	80	3.15	110	4.33	130	5.12	130	5.12	180	7.09	180	7.09
Open Center to Top	C	155	6.10	155	6.10	155	6.10	175	6.89	220	8.66	240	9.45	280	11.02	350	13.78
Flow Passageway	D	7	0.28	9	0.35	13	0.51	18	0.69	23	0.89	30	1.16	35	1.38	46	1.79
Approx. Weight	kg/lb	2.1	4.6	2.1	4.6	2.1	4.6	2.6	5.7	5.9	13.0	6.7	14.7	12.2	26.8	17.2	37.8

End to End dimensions according to OMB Standards

BW9-YL930

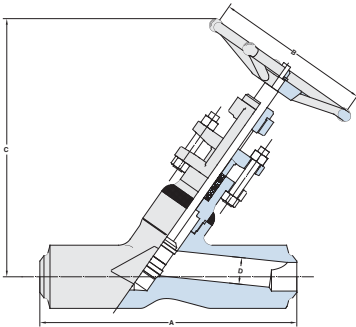

RATINGS: Carbon Steel
Class 1500 - 3705 psi @100°F - *Class 1690 - 4198 psi @100°F

CLASS 1500-1690 WELDED BONNET - FULL BORE - ASME B16.34

Outside Screw & Yoke - Butt Weld Ends

FULL BORE	BW9-YL930	1/4		3/8		1/2		3/4		1		1 1/4		1 1/2		2	
		mm	in	mm	in	mm	in	mm	in	mm	in	mm	in	mm	in	mm	in
End to End	A	216	8.50	216	8.50	216	8.50	273	10.75	273	10.75	308	12.13	308	12.13	384	15.12
Handwheel	B	110	4.33	110	4.33	110	4.33	130	5.12	130	5.12	180	7.09	180	7.09	180	7.09
Open Center to Top	C	170	6.69	170	6.69	170	6.69	240	9.45	250	9.84	280	11.02	335	13.19	420	16.54
Flow Passageway	D	7	0.28	9	0.35	13	0.51	18	0.69	23	0.89	30	1.16	35	1.38	46	1.79
Approx. Weight	kg/lb	2.6	5.7	2.6	5.7	2.6	5.7	6.7	14.7	7.6	16.7	12.2	26.8	13.7	30.1	18.7	41.1

End to End dimensions according to OMB Standards

BW25-YL2530

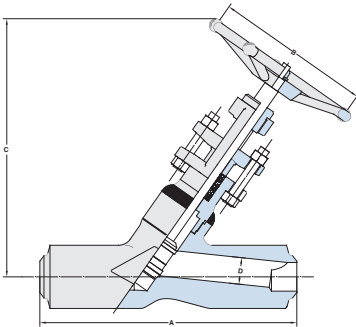

RATINGS: Carbon Steel
Class 2500 - 6170 psi @100°F - *Class 2680 - 6664 psi @100°F

CLASS 2500-2680 WELDED BONNET - FULL BORE - ASME B16.34

Outside Screw & Yoke - Butt Weld Ends

FULL BORE	BW25-YL2530	1/4		3/8		1/2		3/4		1		1 1/4		1 1/2		2	
		mm	in	mm	in	mm	in	mm	in	mm	in	mm	in	mm	in	mm	in
End to End	A	273	10.75	273	10.75	273	10.75	273	10.75	308	12.13	308	12.13	384	15.12	470	18.50
Handwheel	B	130	5.12	130	5.12	130	5.12	130	5.12	180	7.09	180	7.09	180	7.09	300	11.81
Open Center to Top	C	280	11.02	280	11.02	280	11.02	280	11.02	360	14.17	370	14.57	420	16.54	540	21.26
Flow Passageway	D	7	0.28	9	0.35	13	0.51	18	0.69	23	0.89	30	1.16	35	1.38	46	1.79
Approx. Weight	kg/lb	6.6	14.5	6.6	14.5	6.6	14.5	9.1	20.0	11.2	24.6	13.5	29.7	22.2	48.8	50.5	111.1

End to End dimensions according to OMB Standards

YL4530

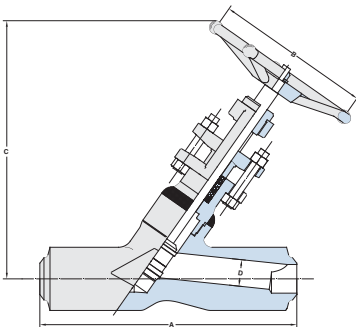

RATINGS: Carbon Steel - 11110 psi @100°F

CLASS 4500 WELDED BONNET - FULL BORE - ASME B16.34

Outside Screw & Yoke - Butt Weld Ends

FULL BORE	YL4530	1/4		3/8		1/2		3/4		1		1 1/4		1 1/2		2	
		mm	in	mm	in	mm	in	mm	in	mm	in	mm	in	mm	in	mm	in
End to End	A	308	12.13	308	12.13	308	12.13	308	12.13	308	12.13	-	-	470	18.50	470	18.50
Handwheel	B	180	7.09	180	7.09	180	7.09	180	7.09	180	7.09	-	-	400	15.75	400	15.75
Open Center to Top	C	350	13.78	350	13.78	350	13.78	350	13.78	380	14.96	-	-	453	17.83	453	17.83
Flow Passageway	D	7	0.28	9	0.35	11	0.43	11	0.43	15	0.59	-	-	26	1.02	28	1.10
Approx. Weight	kg/lb	12.8	28.2	12.8	28.2	12.8	28.2	12.6	27.7	13.7	30.1	-	-	48.6	106.92	50.6	111.3

End to End dimensions according to OMB Standards



Y-PATTERN GLOBE VALVES



BW6-YB630

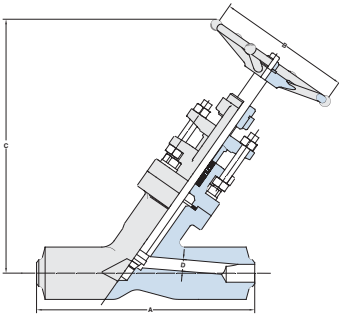

RATINGS: Carbon Steel - 1975 psi @100°F

CLASS 800 BOLTED BONNET - FULL BORE - ASME B16.34

Outside Screw & Yoke - Threaded and Socket Weld Ends

FULL BORE	BW6-YB630	1/4		3/8		1/2		3/4		1		1 1/4		1 1/2		2	
		mm	in	mm	in	mm	in	mm	in	mm	in	mm	in	mm	in	mm	in
End to End	A	216	8.50	216	8.50	216	8.50	216	8.50	273	10.75	273	10.75	308	12.13	384	15.12
Handwheel	B	80	3.15	80	3.15	80	3.15	110	4.33	130	5.12	130	5.12	180	7.09	180	7.09
Open Center to Top	C	205	8.07	205	8.07	205	8.07	215	8.46	270	10.63	300	11.81	330	12.99	400	15.75
Flow Passageway	D	7	0.28	9	0.35	13	0.51	17.5	0.69	22.5	0.89	29.5	1.16	35	1.38	45.5	1.79
Approx. Weight	kg/lb	3.2	7.0	3.2	7.04	3.2	7.0	3.3	7.3	7.9	17.4	8.6	18.9	14.9	32.78	23.2	51.0

End to End dimensions according to OMB Standards

BW9-YB930

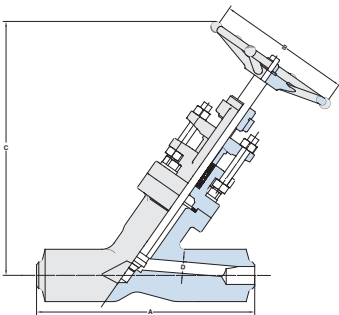

RATINGS: Carbon Steel
Class 1500 - 3705 psi @100°F - *Class 1690 - 4198 psi @100°F

CLASS 1500-1690 BOLTED BONNET - FULL BORE - ASME B16.34

Outside Screw & Yoke - Butt Weld Ends

FULL BORE	BW9-YB930	1/4		3/8		1/2		3/4		1		1 1/4		1 1/2		2	
		mm	in	mm	in	mm	in	mm	in	mm	in	mm	in	mm	in	mm	in
End to End	A	216	8.50	216	8.50	216	8.50	273	10.75	273	10.75	308	12.13	384	15.12	384	15.12
Handwheel	B	110	4.33	110	4.33	110	4.33	130	5.12	130	5.12	180	7.09	180	7.09	180	7.09
Open Center to Top	C	190	7.48	190	7.48	190	7.48	270	10.63	280	11.02	315	12.40	375	14.76	460	18.11
Flow Passageway	D	7	0.28	9	0.35	11	0.43	15	0.59	19.5	0.77	27.5	1.08	31.5	1.24	39	1.54
Approx. Weight	kg/lb	4.1	9.0	4.1	9.02	4.1	9.0	8.1	17.8	8.6	18.9	13.4	29.5	25.2	55.4	30.5	67.1

End to End dimensions according to OMB Standards

BW25-YB2530

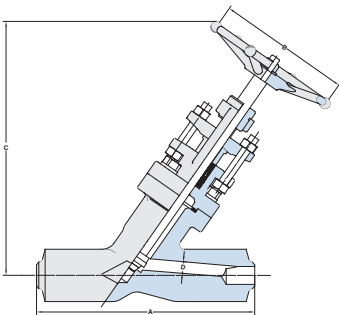

RATINGS: Carbon Steel
Class 2500 - 6170 psi @100°F - *Class 2680 - 6664 psi @100°F

CLASS 2500-2680 BOLTED BONNET - FULL BORE - ASME B16.34

Outside Screw & Yoke - Butt Weld Ends

FULL BORE	BW25-YB2530	1/4		3/8		1/2		3/4		1		1 1/4		1 1/2		2	
		mm	in	mm	in	mm	in	mm	in	mm	in	mm	in	mm	in	mm	in
End to End	A	273	10.75	273	10.75	273	10.75	308	12.13	308	12.13	384	15.12	384	15.12	470	18.50
Handwheel	B	130	5.12	130	5.12	130	5.12	130	5.12	180	7.09	180	7.09	180	7.09	300	11.81
Open Center to Top	C	280	11.02	280	11.02	280	11.02	280	11.02	330	12.99	375	14.76	460	18.11	620	24.41
Flow Passageway	D	7	0.28	9	0.35	11	0.43	15	0.59	19.5	0.77	27.5	1.08	31.5	1.24	39	1.54
Approx. Weight	kg/lb	7.3	16.1	7.3	16.06	7.3	16.1	15.4	33.9	16.4	36.1	25.2	55.4	30.5	67.1	55.4	121.9

End to End dimensions according to OMB Standards



1-Y630 / 3-Y630 / 6-Y630

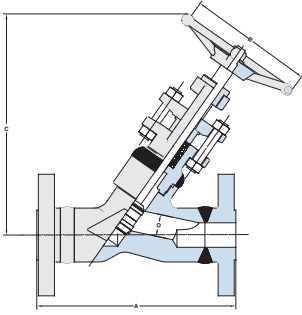

RATINGS: Carbon Steel
 Class 150 - 285 psi @100°F - Class 300 - 740 psi @100°F
 Class 600 - 1480 psi @100°F

CLASS 150-300-600 WELDED BONNET - FULL BORE - ISO 15761 BS 5352

Outside Screw & Yoke - Flanged Ends according to ASME B16.5

FULL BORE		1/4		3/8		1/2		3/4		1		1 1/4		1 1/2		2			
		mm	in	mm	in	mm	in	mm	in	mm	in	mm	in	mm	in	mm	in		
Class 150	1-Y630	A		-	-	-	-	152	5.98	178	7.01	203	7.99	-	-	229	9.02	267	10.51
Class 300	3-Y630	A		-	-	-	-	152	5.98	178	7.01	203	7.99	-	-	229	9.02	267	10.51
Class 600	6-Y630	A		-	-	-	-	165	6.50	190	7.48	216	8.50	-	-	241	9.49	292	11.50
Handwheel		B		-	-	-	-	80	3.15	110	4.33	130	5.12	-	-	180	7.09	180	7.09
Open Center to Top		C		-	-	-	-	155	6.10	175	6.89	220	8.66	-	-	280	11.02	350	13.78
Flow Passageway		D		-	-	-	-	13	0.51	17.5	0.69	22.5	0.89	-	-	35	1.38	45.5	45.50
Approx. Weight	Class 150	kg/lb	-	-	-	-	3	6.6	3.9	8.6	6.3	13.9	-	-	12.4	27.3	18.1	39.8	
	Class 300	kg/lb	-	-	-	-	3.4	7.5	4.7	10.3	7.7	16.9	-	-	16	35.2	20.9	46.0	
	Class 600	kg/lb	-	-	-	-	3.4	7.5	4.3	9.5	8.1	17.8	-	-	17.2	37.8	23.7	52.1	

9-Y930

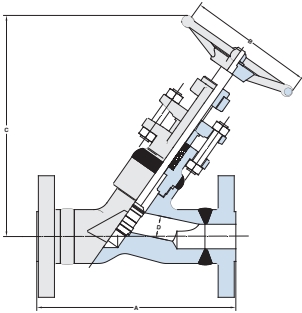

RATINGS: Carbon Steel
 Class 1500 - 3705 psi @100°F

CLASS 1500 WELDED BONNET - FULL BORE - ISO 15761 BS 5352

Outside Screw & Yoke - Flanged Ends according to ASME B16.5

FULL BORE		9-Y930		1/4		3/8		1/2		3/4		1		1 1/4		1 1/2		2	
		mm	in	mm	in	mm	in	mm	in	mm	in	mm	in	mm	in	mm	in	mm	in
End to End		A		-	-	-	-	216	8.50	229	9.02	254	10.00	-	-	305	12.01	368	14.49
Handwheel		B		-	-	-	-	110	4.33	130	5.12	130	5.12	-	-	180	7.09	180	7.09
Open Center to Top		C		-	-	-	-	170	6.69	240	9.45	250	9.84	-	-	335	13.19	420	16.54
Flow Passageway		D		-	-	-	-	13	0.51	18	0.69	23	0.89	-	-	35	1.38	46	1.79
Approx. Weight		kg/lb		-	-	-	-	6.3	13.9	11.3	24.9	14.1	31.0	-	-	23	50.6	35.8	78.8

25-Y2530

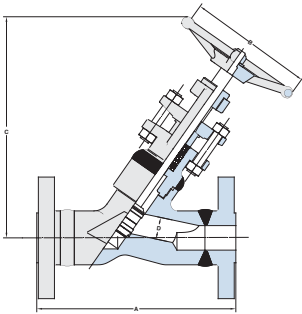

RATINGS: Carbon Steel
 Class 2500 - 6170 psi @100°F

CLASS 2500 WELDED BONNET - FULL BORE - ISO 15761 BS 5352

Outside Screw & Yoke - Flanged Ends according to ASME B16.5

FULL BORE		25-Y2530		1/4		3/8		1/2		3/4		1		1 1/4		1 1/2		2	
		mm	in	mm	in	mm	in	mm	in	mm	in	mm	in	mm	in	mm	in	mm	in
End to End		A		-	-	-	-	264	10.39	273	10.75	308	12.13	-	-	384	15.12	451	17.76
Handwheel		B		-	-	-	-	130	5.12	130	5.12	180	7.09	-	-	180	7.09	300	11.81
Open Center to Top		C		-	-	-	-	280	11.02	280	11.02	360	14.17	-	-	420	16.54	540	21.26
Flow Passageway		D		-	-	-	-	13	0.51	18	0.69	23	0.89	-	-	35	1.38	46	1.79
Approx. Weight		kg/lb		-	-	-	-	12.0	26.4	15.5	34.1	19.6	43.1	-	-	42.1	92.6	73.3	161.3



Y-PATTERN GLOBE VALVES



1-Y630-BB / 3-Y630-BB / 6-Y630-BB

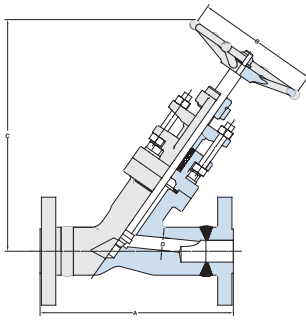

RATINGS: Carbon Steel
 Class 150 - 285 psi @100°F - Class 300 - 740 psi @100°F
 Class 600 - 1480 psi @100°F

CLASS 150-300-600 BOLTED BONNET - FULL BORE - ISO 15761 BS 5352

Outside Screw & Yoke - Flanged Ends according to ASME B16.5

FULL BORE		1/4		3/8		1/2		3/4		1		1 1/4		1 1/2		2	
		mm	in	mm	in	mm	in	mm	in	mm	in	mm	in	mm	in	mm	in
Class 150	1-Y630-BB	A		-	-	152	5.98	178	7.01	203	7.99	-	-	229	9.02	267	10.51
Class 300	3-Y630-BB	A		-	-	152	5.98	178	7.01	203	7.99	-	-	229	9.02	267	10.51
Class 600	6-Y630-BB	A		-	-	165	6.50	190	7.48	216	8.50	-	-	241	9.49	292	11.50
Handwheel		B		-	-	80	3.15	110	4.33	130	5.12	-	-	180	7.09	180	7.09
Open Center to Top		C		-	-	205	8.07	215	8.46	270	10.63	-	-	330	12.99	400	15.75
Flow Passageway		D		-	-	13	0.51	17.5	0.69	22.5	0.89	-	-	35	1.38	45.5	1.79
Approx. Weight	Class 150	kg/lb	-	-	-	4.1	9.0	4.6	10.1	8.3	18.3	-	-	15.3	33.7	22.3	49.1
	Class 300	kg/lb	-	-	-	4.5	10	5.4	11.9	9.7	21.3	-	-	18.9	41.6	25.1	55.2
	Class 600	kg/lb	-	-	-	4.5	10	5	11.0	10.1	22.2	-	-	20.1	44.2	27.9	61.4

9-Y930-BB

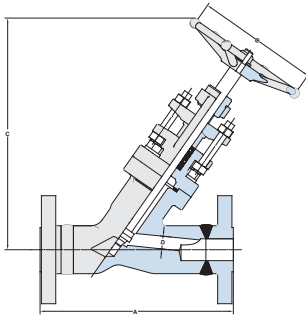

RATINGS: Carbon Steel
 Class 1500 - 3705 psi @100°F

CLASS 1500 BOLTED BONNET - FULL BORE - ISO 15761 BS 5352

Outside Screw & Yoke - Flanged Ends according to ASME B16.5

FULL BORE		9-Y930-BB		1/4		3/8		1/2		3/4		1		1 1/4		1 1/2		2	
		mm	in	mm	in	mm	in	mm	in	mm	in	mm	in	mm	in	mm	in	mm	in
End to End		A		-	-	216	8.50	229	9.02	254	10.00	-	-	305	12.01	368	14.49		
Handwheel		B		-	-	110	4.33	130	5.12	130	5.12	-	-	180	7.09	180	7.09		
Open Center to Top		C		-	-	215	8.46	270	10.63	280	11.02	-	-	375	14.76	460	18.11		
Flow Passageway		D		-	-	11	0.43	15	0.59	19.5	0.77	-	-	31.5	1.24	39	1.54		
Approx. Weight		kg/lb		-	-	7.8	17.2	12.7	27.9	15	33.0	-	-	31.6	69.5	46.8	103.0		

25-Y2530-BB

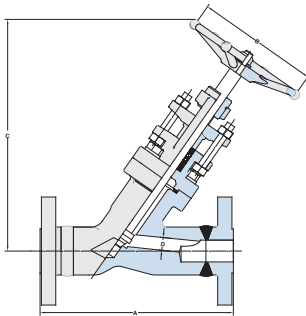

RATINGS: Carbon Steel
 Class 2500 - 6170 psi @100°F

CLASS 2500 BOLTED BONNET - FULL BORE - ISO 15761 BS 5352

Outside Screw & Yoke - Flanged Ends according to ASME B16.5

FULL BORE		25-Y2530-BB		1/4		3/8		1/2		3/4		1		1 1/4		1 1/2		2	
		mm	in	mm	in	mm	in	mm	in	mm	in	mm	in	mm	in	mm	in	mm	in
End to End		A		-	-	264	10.39	273	10.75	308	12.13	-	-	384	15.12	451	17.76		
Handwheel		B		-	-	130	5.12	130	5.12	180	7.09	-	-	180	7.09	300	11.81		
Open Center to Top		C		-	-	280	11.02	280	11.02	330	12.99	-	-	460	18.11	620	24.41		
Flow Passageway		D		-	-	11	0.43	15	0.59	19.5	0.77	-	-	31.5	1.24	39	1.54		
Approx. Weight		kg/lb		-	-	12.7	27.9	20.4	44.9	25	55	-	-	49.6	109.1	78.5	172.7		



CLASS	JOINT	BORE	STANDARD	SCREW & YOKE	ENDS	PAGE	OMB FIG.	VOGT FIG.
800	Bolted Bonnet	SB	API 602 - ISO 15761	Outside	NPT&SW Ends	22	830	12141
800	Bolted Bonnet	FB	BS 5352	Outside	NPT&SW Ends	22	630	13141
800	Welded Bonnet	SB	API 602 - ISO 15761	Outside	NPT&SW Ends	22	L830	2821
800	Welded Bonnet	FB	BS 5352	Outside	NPT&SW Ends	22	L630	3821
800	Welded Bonnet	SB	API 602 - ISO 15761	Inside	NPT&SW Ends	22	L820	N/A*
800	Welded Bonnet	FB	BS 5352	Inside	NPT&SW Ends	22	L620	N/A*
1500	Bolted Bonnet	SB	API 602 - ISO 15761	Outside	NPT&SW Ends	22	R930	52141
1500	Bolted Bonnet	FB	BS 5352	Outside	NPT&SW Ends	22	930	53141
1500	Welded Bonnet	SB	API 602 - ISO 15761	Outside	NPT&SW Ends	23	LR930	15821
1500	Welded Bonnet	FB	BS 5352	Outside	NPT&SW Ends	23	L930	16821
1500	Ring Joint BB	FB	BS 5352	Outside	NPT&SW Ends	23	RJ930	N/A*
2500	Ring Joint BB	FB	ASME B16.34	Outside	SW&BW Ends	23	RJ2530	N/A*
2500	Welded	FB	ASME B16.34	Outside	SW&BW Ends	23	L2530	66723
4500	Ring Joint BB	FB	ASME B16.34	Outside	SW&BW Ends	24	RJ4530	N/A*
4500	Welded Bonnet	FB	ASME B16.34	Outside	SW&BW Ends	24	L4530	N/A*
4500	Ring Joint BB	FB	ASME B16.34	Outside	BW&C Ends	24	RJ-4530-BW	N/A*
4500	Welded Bonnet	FB	ASME B16.34	Outside	BW&C Ends	24	L4530-BW	N/A*
150	Bolted Bonnet	SB	API 602 - ISO 15761	Outside	F Ends	25	F1-830	22473
300	Bolted Bonnet	SB	API 602 - ISO 15761	Outside	F Ends	25	F3-830	33483
600	Bolted Bonnet	SB	API 602 - ISO 15761	Outside	F Ends	25	F6-830	33493
150	Bolted Bonnet	FB	BS 5352	Outside	F Ends	25	F1-630	N/A*
300	Bolted Bonnet	FB	BS 5352	Outside	F Ends	25	F3-630	N/A*
600	Bolted Bonnet	FB	BS 5352	Outside	F Ends	25	F6-630	N/A*
1500	Ring Joint BB	FB	BS 5352	Outside	F Ends	25	F9-RJ-930	N/A*
2500	Ring Joint BB	FB	BS 5352	Outside	F Ends	25	F25-RJ2530	N/A*
800	Welded Bonnet	FB	ASME B16.34	Outside	NPT&SW Ends	26	YL630	810
1500	Welded Bonnet	FB	ASME B16.34	Outside	NPT&SW Ends	26	YL930	1510
1690	Welded Bonnet	FB	ASME B16.34	Outside	NPT&SW Ends	26	YL930	810
2500	Welded Bonnet	FB	ASME B16.34	Outside	NPT&SW Ends	26	YL2530	2510
2680	Welded Bonnet	FB	ASME B16.34	Outside	NPT&SW Ends	26	YL2530	2510
4500	Welded Bonnet	FB	ASME B16.34	Outside	NPT&SW Ends	26	YL4530	4150
800	Bolted Bonnet	FB	ASME B16.34	Outside	NPT&SW Ends	27	YB630	
1500	Bolted Bonnet	FB	ASME B16.34	Outside	NPT&SW Ends	27	YB930	
1690	Bolted Bonnet	FB	ASME B16.34	Outside	NPT&SW Ends	27	YB930	
2500	Bolted Bonnet	FB	ASME B16.34	Outside	NPT&SW Ends	27	YB2530	
2680	Bolted Bonnet	FB	ASME B16.34	Outside	NPT&SW Ends	27	YB2530	
600	Welded Bonnet	FB	ASME B16.34	Outside	NPT&SW Ends	28	BW6-YL630	
1500	Welded Bonnet	FB	ASME B16.34	Outside	NPT&SW Ends	28	BW9-YL930	
1690	Welded Bonnet	FB	ASME B16.34	Outside	NPT&SW Ends	28	BW9-YL930	



GLOBE VALVES



CLASS	JOINT	BORE	STANDARD	SCREW & YOKE	ENDS	PAGE	OMB FIG.	VOGT FIG.
2500	Welded Bonnet	FB	ASME B16.34	Outside		28	BW25-YL2530	
2680	Welded Bonnet	FB	ASME B16.34	Outside		28	BW25-YL2530	
4500	Welded Bonnet	FB	ASME B16.34	Outside		28	YL4530	
800	Bolted Bonnet	FB	ASME B16.34	Outside		29	BW9-YB630	
1500	Bolted Bonnet	FB	ASME B16.34	Outside		29	BW9-YB930	
1690	Bolted Bonnet	FB	ASME B16.34	Outside		29	BW9-YB930	
2500	Bolted Bonnet	FB	ASME B16.34	Outside		29	BW25-YB2530	
2680	Bolted Bonnet	FB	ASME B16.34	Outside		29	BW25-YB2530	
150	Welded Bonnet	FB	API 602 - ISO 15761 BS 5352	Outside		30	1-Y630	
300	Welded Bonnet	FB	API 602 - ISO 15761 BS 5352	Outside		30	3-Y630	
600	Welded Bonnet	FB	API 602 - ISO 15761 BS 5352	Outside		30	6-Y930	
1500	Welded Bonnet	FB	API 602 - ISO 15761 BS 5352	Outside		30	3-Y630	
2500	Welded Bonnet	FB	API 602 - ISO 15761 BS 5352	Outside		30	25-Y2530	
150	Bolted Bonnet	FB	API 602 - ISO 15761 BS 5352	Outside		31	1-Y630-BB	
300	Bolted Bonnet	FB	API 602 - ISO 15761 BS 5352	Outside		31	3-Y630-BB	
600	Bolted Bonnet	FB	API 602 - ISO 15761 BS 5352	Outside		31	6-Y930-BB	
1500	Bolted Bonnet	FB	API 602 - ISO 15761 BS 5352	Outside		31	3-Y630-BB	
2500	Bolted Bonnet	FB	API 602 - ISO 15761 BS 5352	Outside		31	25-Y2530-BB	

NOTE

SB	STANDARD BORE
FB	FULL BORE
NPT&SW ENDS	THREADED AND SOCKET WELD ENDS ACCORDING TO ASME B16.11
SW&BW ENDS	SOCKET WELD ENDS ACCORDING TO ASME B16.11 AND BUTT WELD ENDS ACCORDING TO ASME B16.25
BW&C	BUTT WELDED ACCORDING TO ASME B16.25 AND CLAMP ENDS ACCORDING TO MFGS STANDARDS
F ENDS	INTEGRAL FLANGED ENDS ACCORDING TO ASME B16.5
W ENDS	FLANGED ENDS ACCORDING TO ASME B16.5
N/A*	FIGURE VALVE IS NOT INCLUDED IN THE BFE OR VOGT CATALOG

VOGT SERIES INDICATED ABOVE INCLUSIVE OF MATERIALS





Check valves are unidirectional self-activated valves used to prevent systems' reverse flow and to protect other pipeline devices (pumps, compressors, etc.).

OMB manufactures three different closure element versions to meet a wide variety of applications: Piston, Ball and Swing.

Our piston check valves (as per OMB's standard) are supplied with a spring, an added feature that makes possible their installation throughout the pipeline, vertically or horizontally; critical to completing systems design.

It is worth mentioning that, unless requested by the customer, OMB's ball check valves, are supplied without spring.

OMB pays attention to any detail to its design and manufacturing processes, in order to lower noise in operation conditions and unusual excessive wear on the closure components; guaranteeing the best of performances in the valve's lifetime.

CONSTRUCTION

ISO15761 2nd ed.,2002
API602 10th.ed, 2015
ASME B16.34 2013 ed.

T-Pattern, bolted or
welded bonnet

size 1/2"-2"

Close Die Forging

Full and Standard Bore

150, 300, 600, 800,
1500, 2500, 4500



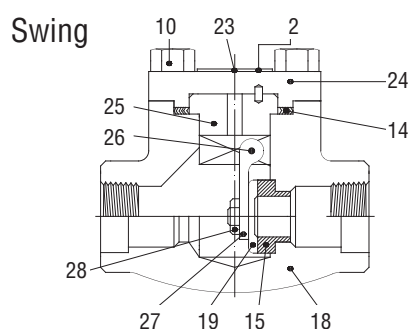
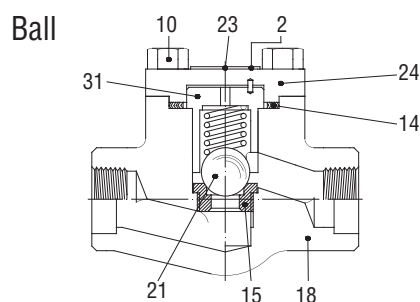
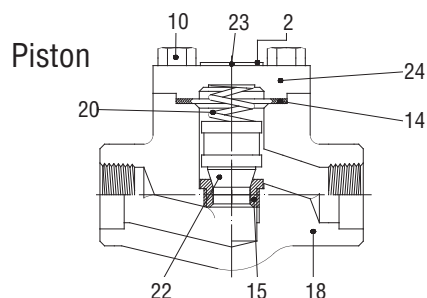

2	NAMEPLATE	A corrosion resistant metal.
10	BOLTS	Unless other materials are agreed between the purchaser and manufacturer, refer to the recommended bolting material in Annex G of API 602.
14	GASKET	Refer to API 602 (see 5.5.3).
15	SEAT	The base material of the seat ring, when used, shall be of a nominal material composition equal to the body material or the stem material. Refer to API 602 (see 6.1.4).
18	BODY	A forging, forged bar or casting material as selected from ASME B16.34, Group 1, 2 or Group 3 and listed in Table 1 of API 602.
19	DISC	The base material of the wedge/disc shall be of a nominal material composition equal to the body material or the stem material. Refer to API 602. (see 6.1.4).
20	SPRING	Similar material composition as would be used for a valve stem, based on the valve trim requirement.
21	BALL	The base material of the wedge/disc shall be of a nominal material composition equal to the body material or the stem material. Refer to API 602. (see 6.1.4).
22	PISTON	The base material of the wedge/disc shall be of a nominal material composition equal to the body material or the stem material. Refer to API 602. (see 6.1.4).
23	RIVET*	Manufacturer standard, refer to table below.
24	BONNET	A forging, forged bar or casting material as selected from ASME B16.34, Group 1, 2 or Group 3 and listed in Table 1 of API 602.
25	SUPPORT*	Manufacturer standard, refer to table below.
26	HINGE PIN	Similar material composition as would be used for a valve stem, based on the valve trim requirement.
27	DISC HINGE	Similar material composition as would be used for a valve stem, based on the valve trim requirement.
28	DISC NUT	Similar material composition as would be used for a valve stem, based on the valve trim requirement.
31	BALL GUIDE*	Manufacturer standard, refer to table below.

DESCRIPTION	A105N/F6	A105N/F6HFS	LF2/F304	F11/F6HFS	F304/F304	F316/F316
RIVET	316	316	316	316	316	316
NAMEPLATE	Aluminium	Aluminium	Aluminium	Aluminium	Aluminium	Aluminium
BOLTS	B7	B7	L7	B16	B8M CL.1	B8M CL.1
BONNET/COVER	A105N	A105N	LF2	F11 Cl.2	304/304L	316/316L
GASKET	316+Graphite	316+Graphite	316+Graphite	316+Graphite	316+Graphite	316+Graphite
SEAT	F6a Cl.2 (410)	410 HF	304/304L	410 HF	304/304L	316
SPRING (*)	AISI 301	AISI 301	AISI 301	AISI 301	AISI 301	X-750
PISTON	F6a Cl.2 (410)	F6a Cl.2 (410)	304/304L	F6a Cl.2 (410)	304/304L	316
BODY	A105N	A105N	LF2	F11 Cl.2	304/304L	316/316L
BALL	F6a Cl.2 (410)	F6a Cl.2 (410)	316	F6a Cl.2 (410)	316	316
BALL GUIDE	LF2	LF2	LF2	316	316	316
DISC	F6a Cl.2 (410)	F6a Cl.2 (410)	304/304L	F6a Cl.2 (410)	304/304L	316
SUPPORT	LF2	LF2	LF2	316	316	316
HINGE PIN	F6a Cl.2 (410)	F6a Cl.2 (410)	316	F6a Cl.2 (410)	316	316
DISC HINGE	F6a Cl.2 (410)	F6a Cl.2 (410)	316	F6a Cl.2 (410)	316	316
DISC NUT	Gr.8M	Gr.8M	Gr.8M	Gr.8M	Gr.8M	Gr.8M

NOTE * Spring is an optional feature for Ball Check valves, supplied upon request.



840/850/860/640/650/660

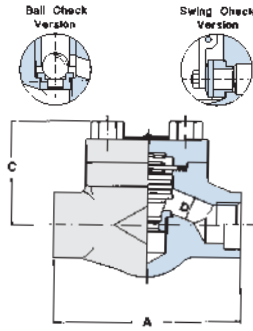

RATINGS: Carbon Steel 1975 p.s.i. @ 100°F

CLASS 800 PISTON, BALL AND SWING TYPE - STANDARD BORE - API602/ISO 15761 - FULL BORE - BS 5352

Bolted Cover - Threaded and Socket Weld Ends

STANDARD PORT		PISTON BALL SWING	-		1/2		3/4		1		1 1/4		1 1/2		2		-	
FULL BORE		PISTON BALL SWING	1/4		3/8		1/2		3/4		1		1 1/4		1 1/2		2	
			mm	in.	mm	in.	mm	in.	mm	in.	mm	in.	mm	in.	mm	in.	mm	in.
End to End	Piston - Ball	A	80	3.14	80	3.14	90	3.54	110	4.33	127	5.00	155	6.10	170	6.69	210	8.26
	Swing	A	80	3.14	80	3.14	90	3.54	110	4.33	127	5.00	127	5.00	127	5.00	210	8.26
Open Center to Top		C	53	2.08	53	2.08	60	2.36	73	2.87	80	3.14	98	3.85	118	4.64	150	5.90
Dia of Port	Piston - Ball	D	7	0.28	9	0.35	13	0.51	17.5	0.69	23	0.88	29.5	1.16	35	1.38	45.5	1.79
	Swing	D	8	0.31	9.6	0.38	14	0.55	18	0.70	24	0.94	30	1.18	37	1.45	48	1.89
Approx. Weight	Piston - Ball	Kg/Lb	1.3	2.8	1.3	2.8	1.4	3.0	2.4	5.2	4.0	8.8	7.4	16.2	8	17.6	18	39.6
	Swing	Kg/Lb	1.3	2.8	1.3	2.8	1.4	3.0	2.4	5.2	4.0	8.8	5.5	12.1	6.5	14.3	17.5	38.5

L840/L850/L640/L650

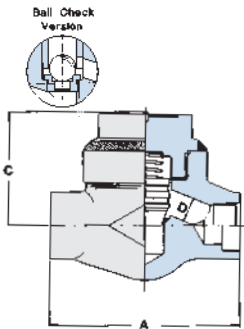

RATINGS: Carbon Steel 1975 p.s.i. @ 100°F

CLASS 800 PISTON AND BALL TYPE - STANDARD BORE - API602/ISO 15761 - FULL BORE - BS 5352

Welded Cover - Threaded and Socket Weld Ends

STANDARD PORT		PISTON BALL	-		1/2		3/4		1		1 1/4		1 1/2		2		-	
FULL BORE		PISTON BALL	1/4		3/8		1/2		3/4		1		1 1/4		1 1/2		2	
			mm	in.	mm	in.	mm	in.	mm	in.	mm	in.	mm	in.	mm	in.	mm	in.
End to End		A	80	3.14	80	3.14	90	3.54	110	4.33	127	5.00	155	6.10	170	6.69	210	8.26
Open Center to Top		C	53	2.08	53	2.08	60	2.36	73	2.87	80	3.14	98	3.85	110	4.33	150	5.90
Dia of Port		D	7	0.28	9	0.35	13	0.51	17.5	0.69	23	0.88	29.5	1.16	35	1.38	45.5	1.79
Approx. Weight		Kg/Lb	1.3	2.8	1.3	2.8	1.4	3.0	2.4	5.2	4.0	8.8	7.4	16.2	8	17.6	17	37.4

R940/R950/R960/940/950/960

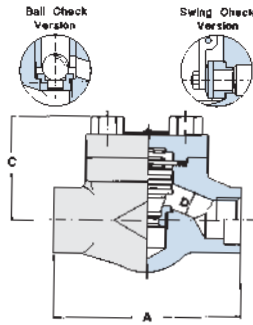

RATINGS: Carbon Steel 3705 p.s.i. @ 100°F

CLASS 1500 PISTON, BALL AND SWING TYPE - STANDARD BORE - API602/ISO 15761 - FULL BORE - BS 5352

Bolted Cover - Threaded and Socket Weld Ends

STANDARD PORT		PISTON BALL SWING	-		1/2		3/4		1		1 1/4		1 1/2		2		-	
FULL BORE		PISTON BALL SWING	1/4		3/8		1/2		3/4		1		1 1/4		1 1/2		2	
			mm	in.	mm	in.	mm	in.	mm	in.	mm	in.	mm	in.	mm	in.	mm	in.
End to End	Piston - Ball	A	90	3.54	90	3.54	110	4.33	127	5.00	155	6.10	170	6.99	210	8.26	210	8.26
	Swing	A	90	3.54	90	3.54	110	4.33	127	5.00	127	5.00	127	5.00	210	8.26	210	8.26
Open Center to Top		C	60	2.36	60	2.36	73	2.87	80	3.14	98	3.85	118	4.64	150	5.90	150	5.90
Dia of Port	Piston - Ball	D	7	0.28	9	0.35	13	0.51	17.5	0.69	21	0.83	28	1.10	33	1.30	37.5	1.48
	Swing	D	8	0.31	9.6	0.38	14	0.55	18	0.70	24	0.94	30	1.18	37	1.45	40	1.57
Approx. Weight	Piston - Ball	Kg/Lb	1.5	3.3	1.5	3.3	2.8	6.1	4.6	10.1	7.4	16.2	9	19.8	19.5	49.9	19	41.8
	Swing	Kg/Lb	1.6	3.5	1.5	3.3	2.4	5.2	4	8.8	6	13.2	9.5	20.9	19	41.8	18.5	40.7

LR940/LR950/L940/L950

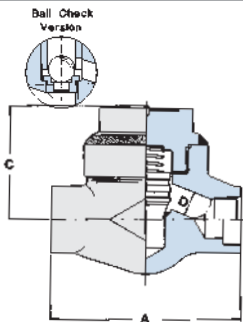

RATINGS: Carbon Steel 3705 p.s.i. @ 100°F

CLASS 1500 PISTON AND BALL TYPE - STANDARD BORE - API602/ISO 15761 - FULL BORE TO BS 5352

Welded Cover - Threaded and Socket Weld Ends

STANDARD PORT		PISTON BALL	-		1/2		3/4		1		1 1/4		1 1/2		2		-	
FULL BORE		PISTON BALL	1/4		3/8		1/2		3/4		1		1 1/4		1 1/2		2	
			mm	in.	mm	in.	mm	in.	mm	in.	mm	in.	mm	in.	mm	in.	mm	in.
End to End		A	90	3.54	90	3.54	110	4.33	127	5.00	155	6.10	170	6.69	210	8.26	210	8.26
Open Center to Top		C	60	2.36	60	2.36	73	2.87	80	3.14	98	3.85	110	4.33	150	5.90	150	5.90
Dia of Port		D	7	0.28	9	0.35	13	0.51	17	0.67	21	0.83	28	1.10	33	1.30	37.5	1.47
Approx. Weight		Kg/Lb	1.5	3.3	1.5	3.3	2.8	6.1	4.6	10.1	7.4	16.3	9	19.8	15	33.0	14.5	31.9



RJ940/RJ950/RJ960

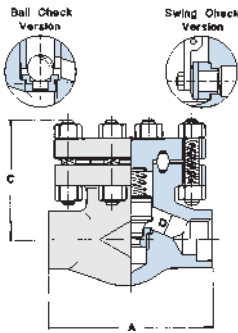

RATINGS: Carbon Steel 3705 p.s.i. @ 100°F

CLASS 1500 PISTON, BALL AND SWING TYPE - FULL BORE TO BS 5352

Round Bolted Cover - Threaded and Socket Weld Ends

FULL BORE	PISTON BALL SWING	1/4		3/8		1/2		3/4		1		1 1/4		1 1/2		2	
		mm	in	mm	in	mm	in	mm	in	mm	in	mm	in	mm	in	mm	in
End to End	A	-	-	-	-	110	4.33	150	5.90	150	5.90	-	-	210	8.26	235	9.25
Open Center to Top	C	-	-	-	-	100	3.93	130	5.11	145	5.70	-	-	160	6.29	195	7.67
Flow passageway	Piston - Ball	D	-	-	-	13	0.51	17	0.67	21	0.83	-	-	33	1.30	37.5	1.48
	Swing	D	-	-	-	14	0.55	18	0.70	24	0.94	-	-	37	1.45	48	1.89
Approx. Weight	Piston - Ball	kg/lb	-	-	-	4	8.8	7.5	16.5	9	19.8	-	-	18.5	40.7	30	66
Weight	Swing	kg/lb	-	-	-	3.8	8.87	7	15.4	8.5	18.7	-	-	17.5	38.5	29	63.8

Spiral wound gasket joint available on request

Ring-Joint gasket according to ASME B16.20 - API 6A.

RJ2540/RJ2550

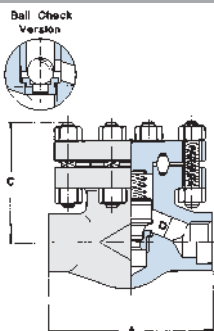

RATINGS: Carbon Steel 6170 p.s.i. @ 100°F

CLASS 2500 PISTON AND BALL TYPE - FULL BORE - ASME B16.34

Round Bolted Cover - Socket and Butt Weld Ends

FULL BORE	PISTON BALL	1/4		3/8		1/2		3/4		1		1 1/4		1 1/2		2	
		mm	in	mm	in	mm	in	mm	in	mm	in	mm	in	mm	in	mm	in
End to End	A	-	-	-	-	150	5.90	150	5.90	210	8.26	-	-	235	9.25	235	9.25
Open Center to Top	C	-	-	-	-	130	5.11	130	5.11	160	6.29	-	-	195	7.67	195	7.67
Flow Passageway	D	-	-	-	-	13	0.51	17	0.67	21	0.83	-	-	33	1.30	35	1.37
Approx. Weight	kg/lb	-	-	-	-	7	15.4	6.8	14.9	17.5	38.5	-	-	29	36.8	29	63.8

Ring-Joint gasket according to ASME B16.20 - API 6A.

L2540/L2550

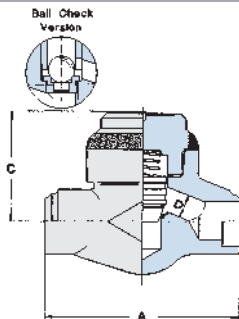

RATINGS: Carbon Steel 6170 p.s.i. @ 100°F

CLASS 2500 PISTON AND BALL TYPE - FULL BORE - ASME B16.34

Welded Cover - Socket and Butt Weld Ends

FULL BORE	PISTON BALL	1/4		3/8		1/2		3/4		1		1 1/4		1 1/2		2	
		mm	in	mm	in	mm	in	mm	in	mm	in	mm	in	mm	in	mm	in
End to End	A	-	-	-	-	127	5.00	155	6.10	170	6.69	-	-	235	9.25	235	9.25
Open Center to Top	C	-	-	-	-	80	3.14	98	3.85	110	4.33	-	-	170	6.69	170	6.69
Flow Passageway	D	-	-	-	-	13	0.51	17	0.67	21	0.83	-	-	33	1.30	35	1.37
Approx. Weight	kg/lb	-	-	-	-	5	11.0	8	17.6	10	22.0	-	-	21.5	47.3	21.3	46.9

RJ4540/RJ4550

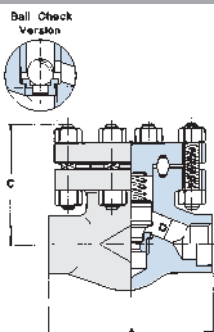

RATINGS: Carbon Steel 11110 p.s.i. @ 100°F

CLASS 4500 PISTON AND BALL TYPE - FULL BORE - ASME B16.34

Round Bolted Cover - Socket and Butt Weld Ends

FULL BORE	PISTON BALL	1/4		3/8		1/2		3/4		1		1 1/4		1 1/2		2	
		mm	in	mm	in	mm	in	mm	in	mm	in	mm	in	mm	in	mm	in
End to End	A	-	-	-	-	210	8.26	210	8.26	235	9.25	-	-	235	9.25	-	-
Open Center to Top	C	-	-	-	-	160	6.29	160	6.29	195	7.67	-	-	195	7.67	-	-
Flow Passageway	D	-	-	-	-	9	0.35	11	0.43	14	0.55	-	-	28	1.10	-	-
Approx. Weight	kg/lb	-	-	-	-	18	39.6	18	39.6	29.5	65.0	-	-	29.5	65.0	-	-

Ring-Joint gasket according to ASME B16.20 - API 6A.



F1-840/F3-840/F6-840/ F1-850/F3-850/F6-850

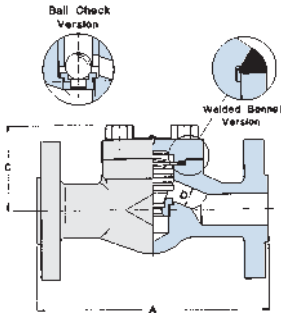

RATINGS: Carbon Steel
 Class 150: 285 p.s.i. @ 100°F - Class 300: 740 p.s.i. @ 100°F
 Class 600: 1480 p.s.i. @ 100°F

CLASS 150-300-600 PISTON AND BALL TYPE - STANDARD BORE - API602/ISO 15761

Bolted Cover - Integral Flanged Ends according to ASME B16.5

STANDARD BORE		1/4		3/8		1/2		3/4		1		1 1/4		1 1/2		2	
		mm	in	mm	in	mm	in	mm	in	mm	in	mm	in	mm	in	mm	in
Class 150	PISTON BALL F1-840	A	-	-	-	108	4.25	117	4.64	127	5.00	-	-	165	6.49	203	7.99
	F1-850																
Class 300	PISTON BALL F3-840	A	-	-	-	152	6.02	178	7.00	203	7.99	-	-	229	9.01	267	10.5
	F3-850																
Class 600	PISTON BALL F6-840	A	-	-	-	165	6.49	190	7.51	216	8.50	-	-	241	9.48	292	11.5
	F6-850																
Center to Top Open	Class 150	C	-	-	-	75	2.95	92	3.62	98	3.85	-	-	98	3.85	110	4.33
	Class 300-600	C	-	-	-	53	2.08	60	2.36	73	2.87	-	-	98	3.85	110	4.33
Flow Passageway		D	-	-	-	9	0.35	13	0.51	17.5	0.69	-	-	29.5	1.16	35	1.37
Approx. Weight	Class 150	kg/lb	-	-	-	2.9	6.4	3.2	7.0	4.3	9.5	-	-	6.5	14.3	14.5	31.9
	Class 300	kg/lb	-	-	-	3.6	7.9	4.2	9.2	6	13.2	-	-	12	26.4	16	35.2
	Class 600	kg/lb	-	-	-	4.1	9.0	4.7	10.4	6.3	13.8	-	-	13	28.6	17	37.4

End to end dimension according to ASME B16.10

F1-860/F3-860/F6-860

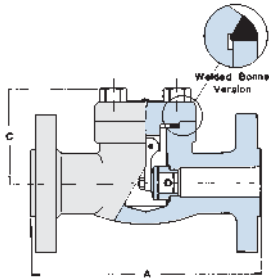

RATINGS: Carbon Steel
 Class 150: 285 p.s.i. @ 100°F - Class 300: 740 p.s.i. @ 100°F
 Class 600: 1480 p.s.i. @ 100°F

CLASS 150-300-600 SWING TYPE - STANDARD BORE - API602/ISO 15761

Round Bolted Cover - Integral Flanged Ends according to ASME B16.5

STANDARD BORE		1/4		3/8		1/2		3/4		1		1 1/4		1 1/2		2	
		mm	in	mm	in	mm	in	mm	in	mm	in	mm	in	mm	in	mm	in
Class 150	F1-860	A	-	-	-	108	4.25	117	4.64	127	5.00	-	-	165	6.49	203	7.99
	F3-860																
Class 300	F3-860	A	-	-	-	152	6.02	178	7.00	216	8.50	-	-	241	9.48	292	11.5
	F6-860																
Class 600	F6-860	A	-	-	-	165	6.49	190	7.51	216	8.50	-	-	241	9.48	292	11.5
Open Center to Top	Class 150	C	-	-	-	75	2.95	92	3.62	98	3.85	-	-	98	3.85	110	4.33
	Class 300-600	C	-	-	-	53	2.08	60	2.36	73	2.87	-	-	98	3.85	110	4.33
Flow Passageway		D	-	-	-	9.6	0.38	14	0.55	18	0.70	-	-	30	1.18	37	1.45
Approx. Weight	Class 150	kg/lb	-	-	-	2.9	6.4	3.2	7.0	4.3	9.5	-	-	6.5	14.3	14.5	31.9
	Class 300	kg/lb	-	-	-	3.6	7.9	4.2	9.2	6.1	13.4	-	-	13	28.6	16	35.2
	Class 600	kg/lb	-	-	-	4.1	9.0	4.7	10.4	6.3	13.8	-	-	13	28.6	17	37.4

End to end dimension according to ASME B16.10

F6-RJ840/F6-RJ850

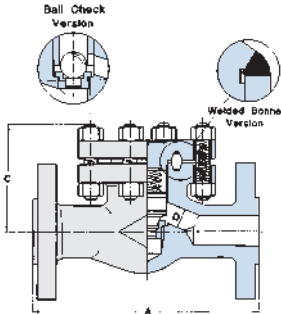

RATINGS: Carbon Steel
 Class 150: 285 p.s.i. @ 100°F - Class 300: 740 p.s.i. @ 100°F
 Class 600: 1480 p.s.i. @ 100°F

CLASS 600 PISTON AND BALL TYPE - FULL BORE - BS 5352

Bolted Cover - Integral Flanged Ends according to ASME B16.5

FULL BORE		1/4		3/8		1/2		3/4		1		1 1/4		1 1/2		2	
		mm	in	mm	in	mm	in	mm	in	mm	in	mm	in	mm	in	mm	in
Class 600	PISTON BALL F6-RJ840	A	-	-	-	165	6.49	190	7.51	216	8.50	-	-	241	9.48	292	11.5
	F6-RJ850																
Open Center to Top	Class 150	C	-	-	-	75	2.95	100	3.93	100	4.33	-	-	120	4.72	147	5.78
	Class 300-600	C	-	-	-	115	4.52	130	5.11	140	5.51	-	-	170	6.69	195	7.67
Flow Passageway		D	-	-	-	13	0.51	17.5	0.69	22.5	0.89	-	-	35	1.37	45.5	1.79
Approx. Weight	Class 150	kg/lb	-	-	-	3.2	7.0	3.5	7.7	4.6	10.1	-	-	7.0	15.4	16	35.2
	Class 300	kg/lb	-	-	-	4.6	10.1	6.1	13.4	9.1	20.0	-	-	16	35.2	21	46.2
	Class 600	kg/lb	-	-	-	4.8	10.5	6.3	13.8	9.3	20.5	-	-	16.5	36.3	22	48.4

End to end dimension according to ANSI B16.10
 Spiral wound gasket joint for #150

Ring-Joint gasket according to ASME B16.20 - API 6A.



F6-RJ660

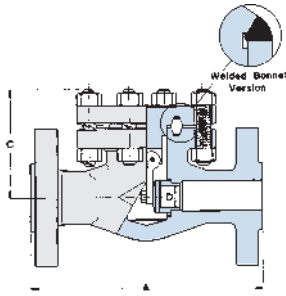

RATINGS: Carbon Steel

Class 150: 285 p.s.i. @ 100°F - Class 300: 740 p.s.i. @ 100°F
Class 600: 1480 p.s.i. @ 100°F

CLASS 600 SWING TYPE - FULL BORE - BS 5352

Round Bolted Cover - Integral Flanged Ends according to ASME B16.5

FULL BORE		1/4		3/8		1/2		3/4		1		1 1/4		1 1/2		2	
		mm	in	mm	in	mm	in	mm	in	mm	in	mm	in	mm	in	mm	in
Class 600 F6-RJ660	A	-	-	-	-	165	6.49	190	7.51	216	8.50	-	-	241	9.48	292	11.5
Open Center to Top	Class 150	C	-	-	-	75	2.95	100	3.93	110	4.33	-	-	120	4.72	147	5.78
	Class 300-600	C	-	-	-	115	4.52	130	5.11	140	5.51	-	-	170	6.69	195	7.67
Flow Passageway	D	-	-	-	-	14	0.55	18	0.70	24	0.94	-	-	37	1.45	48	1.89
Approx. Weight	Class 150	kg/lb	-	-	-	3.1	6.8	3.4	7.5	4.5	9.9	-	-	6.8	14.9	15.7	34.5
	Class 300	kg/lb	-	-	-	4.6	10.1	6.1	13.4	9.3	20.5	-	-	16.5	36.3	21	46.2
	Class 600	kg/lb	-	-	-	4.8	10.5	6.3	13.8	9.3	20.5	-	-	16.5	36.3	22	48.4

End to end dimension according to ANSI B16.10
Spiral wound gasket joint for #150

Ring-Joint gasket according to ASME B16.20 - API 6A.

F9-RJ940/F9-RJ950/F9-RJ960

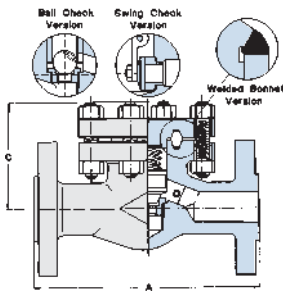

RATINGS: Carbon Steel 3075 p.s.i. @ 100°F

CLASS 1500 PISTON, BALL AND SWING TYPE - FULL BORE - BS 5352

Round Bolted Cover - Integral Flanged Ends according to ASME B16.5

FULL BORE	PISTON BALL SWING	1/4		3/8		1/2		3/4		1		1 1/4		1 1/2		2	
		mm	in	mm	in	mm	in	mm	in	mm	in	mm	in	mm	in	mm	in
End to End	A	-	-	-	-	216	8.50	229	9.01	254	10.0	-	-	305	12.0	368	14.5
Open Center to Top	C	-	-	-	-	130	5.11	140	5.51	155	6.10	-	-	170	6.69	195	7.67
Flow passageway	Piston - Ball	D	-	-	-	13	0.51	17	0.67	21	0.83	-	-	33	1.30	37.5	1.48
	Swing	D	-	-	-	14	0.55	18	0.70	24	0.94	-	-	37	1.45	48	1.89
Approx. Weight	Piston - Ball	kg/lb	-	-	-	8	17.6	14	30.8	17	37.5	-	-	28	61.6	37	81.4
	Swing	kg/lb	-	-	-	7.8	17.1	13.8	30.4	16.5	36.3	-	-	27	59.5	35	77.1

End to end dimension according to ANSI B16.10
Spiral wound gasket joint for #150

Ring-Joint gasket according to ASME B16.20 - API 6A.

F25-RJ2540/ F25-RJ2550

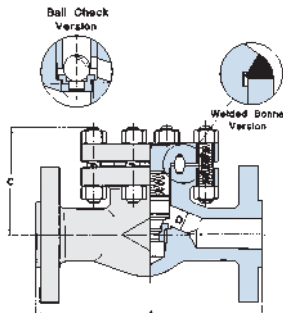

RATINGS: Carbon Steel 6170 p.s.i. @ 100°F

CLASS 2500 PISTON AND BALL TYPE - FULL BORE - ASME B16.34

Round Bolted Cover - Integral Flanged Ends according to ASME B16.5

FULL BORE	PISTON BALL	1/4		3/8		1/2		3/4		1		1 1/4		1 1/2		2	
		mm	in	mm	in	mm	in	mm	in	mm	in	mm	in	mm	in	mm	in
End to End	A	-	-	-	-	264	10.4	273	10.7	308	12.1	-	-	384	15.1	451	17.7
Open Center to Top	C	-	-	-	-	155	6.10	155	6.10	170	6.69	-	-	245	9.64	260	10.23
Flow Passageway	D	-	-	-	-	11	0.43	17	0.67	21	0.83	-	-	33	1.30	37.5	1.48
Approx. Weight	kg/lb	-	-	-	-	17	37.5	21	46.2	28	61.6	-	-	58	127.7	85	187.2

End to end dimension according to ANSI B16.10

Ring-Joint gasket according to ASME B16.20 - API 6A.



YL640

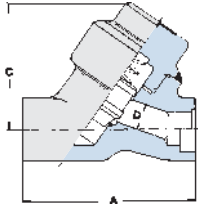

RATINGS: Carbon Steel 1975 p.s.i. @ 100°F

CLASS 800 PISTON TYPE - FULL BORE - ASME B16.34

Welded Cover - Threaded and Socket Weld Ends

FULL BORE	YL640	1/4		3/8		1/2		3/4		1		1 1/4		1 1/2		2	
		mm	in	mm	in	mm	in	mm	in	mm	in	mm	in	mm	in	mm	in
End to End	A	110	4.33	110	4.33	110	4.33	110	4.33	142	5.59	142	5.59	170	6.69	180	7.08
Open Center to Top	C	65	2.55	65	2.55	65	2.55	65	2.55	80	3.14	95	3.74	115	4.52	135	5.31
Flow Passageway	D	7	0.27	9	0.35	13	0.51	17.5	0.68	22.5	0.88	29.5	1.16	35	1.37	45.5	1.79
Approx. Weight	kg/lb	1.2	2.6	1.2	2.6	1.2	2.6	1.2	3.9	3	6.6	3.3	7.2	5.8	12.7	7	15.4

YL940

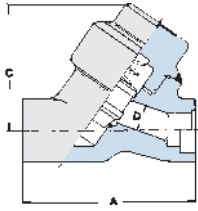

RATINGS: Carbon Steel
Class 1500: 3705 p.s.i. @ 100°F - Class 1690: 4198 p.s.i. @ 100°F

CLASS 1500-1690 WELDED BONNET - FULL BORE - ASME B16.34

Welded Cover - Threaded and Socket Weld Ends

FULL BORE	YL940	1/4		3/8		1/2		3/4		1		1 1/4		1 1/2		2	
		mm	in	mm	in	mm	in	mm	in	mm	in	mm	in	mm	in	mm	in
End to End	A	110	4.33	110	4.33	110	4.33	142	5.59	142	5.59	170	6.69	170	6.69	180	7.08
Open Center to Top	C	70	2.75	70	2.75	70	2.75	100	3.93	100	3.93	120	4.72	120	4.72	140	5.51
Flow Passageway	D	7	0.27	9	0.35	11	0.43	15	0.59	19.5	0.76	27.5	1.08	31.5	1.24	39	1.53
20,9 Approx. Weight	kg/lb	1.5	3.3	1.5	3.3	1.5	3.3	3.2	7.0	3.2	7.0	6	13.2	6.2	13.6	9.5	20.9

YL2540

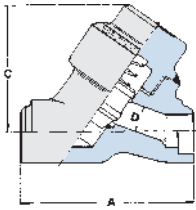

RATINGS: Carbon Steel
Class 2500: 6170 p.s.i. @ 100°F - Class 2680: 6664 p.s.i. @ 100°F

CLASS 2500-2680 WELDED BONNET - FULL BORE - ASME B16.34

Welded Cover - Socket and Butt Weld Ends

FULL BORE	YL2540	1/4		3/8		1/2		3/4		1		1 1/4		1 1/2		2	
		mm	in	mm	in	mm	in	mm	in	mm	in	mm	in	mm	in	mm	in
End to End	A	142	5.59	142	5.59	142	5.59	142	5.59	170	6.69	170	6.69	180	7.08	225	8.86
Open Center to Top	C	115	4.52	115	4.52	115	4.52	120	4.72	150	5.90	150	5.90	160	6.30	170	6.70
Flow Passageway	D	7	0.27	9	0.35	11	0.43	15	0.59	19.5	0.76	27.5	1.08	31.5	1.24	39	1.53
Approx. Weight	kg/lb	3.2	7.0	3.2	7.0	3.5	7.7	3.5	7.7	6.2	13.7	5.6	12.3	10.4	22.9	14	30.8

YL4540

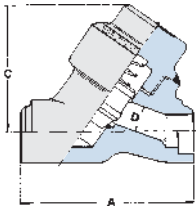

RATINGS: Carbon Steel 11110 p.s.i. @ 100°F

CLASS 4500 PISTON TYPE - FULL BORE - ASME B16.34

Welded Cover - Socket and Butt Weld Ends

FULL BORE	YL4540	1/4		3/8		1/2		3/4		1		1 1/4		1 1/2		2	
		mm	in	mm	in	mm	in	mm	in	mm	in	mm	in	mm	in	mm	in
End to End	A	170	6.69	170	6.69	170	6.69	170	6.69	170	6.69	-	-	225	8.86	225	8.86
Open Center to Top	C	120	4.72	120	4.72	120	4.72	120	4.72	145	5.70	-	-	160	6.30	160	6.30
Flow Passageway	D	7	0.27	9	0.35	11	0.43	11	0.43	15	0.59	-	-	26	1.02	28	1.10
Approx. Weight	kg/lb	8.7	19.1	8.7	19.1	8.7	19.1	8.0	17.6	7.6	16.7	-	-	16.5	36.3	16	35.2



Y-PATTERN CHECK VALVES



YB640

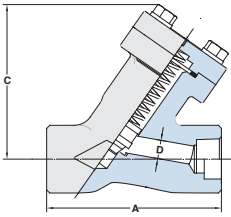

RATINGS: Carbon Steel - 1975 psi @100°F

CLASS 800 PISTON TYPE - FULL BORE - ASME B16.34

Bolted Cover - Threaded and Socket Weld Ends

FULL BORE	YB640	1/4		3/8		1/2		3/4		1		1 1/4		1 1/2		2	
		mm	in	mm	in	mm	in	mm	in	mm	in	mm	in	mm	in	mm	in
End to End	A	110	4.33	110	4.33	110	4.33	110	4.33	142	5.59	142	5.59	170	6.69	180	7.09
Handwheel	B	-	-	-	-	-	-	-	-	-	-	-	-	-	-	-	-
Open Center to Top	C	101.3	3.99	101.3	3.99	101.3	3.99	101.3	3.99	129.5	5.10	129.5	5.10	160.8	6.33	193.7	7.63
Flow Passageway	D	7	0.28	9	0.35	13	0.51	17.5	0.69	22.5	0.89	29.5	1.16	35	1.38	45.5	1.79
Approx. Weight	kg/lb	1.7	3.7	1.7	3.7	1.7	3.7	1.7	3.7	4.2	9.2	4.2	9.2	8.5	18.7	12.0	26.4

YB940

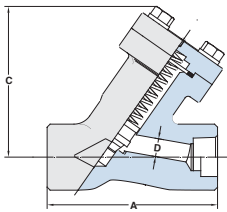

RATINGS: Carbon Steel
Class 1500 - 3705 psi @100°F
*Class 1690 - 4198 psi @100°F

CLASS 1500-1690 PISTON TYPE - FULL BORE - ASME B16.34

Bolted Cover - Threaded and Socket Weld Ends

FULL BORE	YB940	1/4		3/8		1/2		3/4		1		1 1/4		1 1/2		2	
		mm	in	mm	in	mm	in	mm	in	mm	in	mm	in	mm	in	mm	in
End to End	A	110	4.33	110	4.33	100	3.94	142	5.59	142	5.59	170	6.69	170	6.69	180	7.09
Handwheel	B	-	-	-	-	-	-	-	-	-	-	-	-	-	-	-	-
Open Center to Top	C	101.3	3.99	101.3	3.99	101.3	3.99	129.5	5.10	129.5	5.10	160.8	6.33	193.7	7.63	193.7	7.63
Flow Passageway	D	7	0.28	9	0.35	11	0.43	15	0.59	19.5	0.77	27.5	1.08	31.5	1.24	39	1.54
Approx. Weight	kg/lb	1.7	3.7	1.7	3.7	1.7	3.7	4.2	9.2	4.2	9.2	8.5	18.7	12.0	26.4	12.0	26.4

YB2540

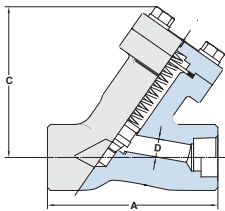

RATINGS: Carbon Steel
Class 1500 - 3705 psi @100°F
*Class 1690 - 4198 psi @100°F

CLASS 2500-2680 PISTON TYPE - FULL BORE - ASME B16.34

Bolted Cover - Socket and Butt Weld Ends

FULL BORE	YB2540	1/4		3/8		1/2		3/4		1		1 1/4		1 1/2		2	
		mm	in	mm	in	mm	in	mm	in	mm	in	mm	in	mm	in	mm	in
End to End	A	142	5.59	142	5.59	142	5.59	170	6.69	170	6.69	180	7.09	180	7.09	225	8.86
Handwheel	B	-	-	-	-	-	-	-	-	-	-	-	-	-	-	-	-
Open Center to Top	C	129.5	5.10	129.5	5.10	129.5	5.10	160.8	6.33	160.8	6.33	193.7	7.63	193.7	7.63	286.1	11.26
Flow Passageway	D	7	0.28	9	0.35	11	0.43	15	0.59	19.5	0.77	27.5	1.08	31.5	1.24	39	1.54
Approx. Weight	kg/lb	4.2	9.2	4.2	9.2	4.2	9.2	8.5	18.7	8.5	18.7	12.0	26.4	12.0	26.4	30.6	67.3



1-YL640 / 3-YL640 / 6-YL640

CLASS 150-300-600 PISTON TYPE - FULL BORE - ASME B16.34

Welded Cover - Flanged Ends according to ASME B16.5

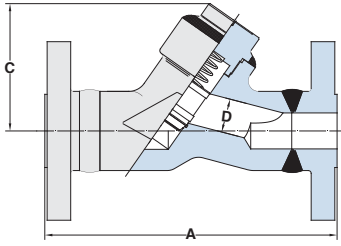

RATINGS: Carbon Steel
 Class 150 - 285 psi @100°F - Class 300 - 740 psi @100°F
 Class 600 - 1480 psi @100°F

FULL BORE		1/4		3/8		1/2		3/4		1		1 1/4		1 1/2		2	
		mm	in	mm	in	mm	in	mm	in	mm	in	mm	in	mm	in	mm	in
Class 150	1-YL640	A		-	-	152	5.98	178	7.01	203	7.99	-	-	229	9.02	267	10.51
Class 300	3-YL640	A		-	-	152	5.98	178	7.01	203	7.99	-	-	229	9.02	267	10.51
Class 600	6-YL640	A		-	-	165	6.50	190	7.48	216	8.50	-	-	241	9.49	292	11.50
Handwheel		B		-	-	-	-	-	-	-	-	-	-	-	-	-	-
Open Center to Top		C		-	-	65	2.56	65	2.56	80	3.15	-	-	115	4.53	135	5.31
Flow Passageway		D		-	-	13	0.51	17.5	0.69	22.5	0.89	-	-	35	1.38	45.5	1.79
Approx. Weight	Class 150	kg/lb	-	-	-	2.8	6.2	3.2	7.0	5.1	11.2	-	-	9.3	20.5	12.2	26.8
	Class 300	kg/lb	-	-	-	3.2	7.0	4	8.8	6.5	14.3	-	-	12.9	28.4	15	33.0
	Class 600	kg/lb	-	-	-	3.2	7.0	3.6	7.9	6.9	15.2	-	-	14.1	31.0	17.8	39.2

9-YL940

CLASS 1500 PISTON TYPE - FULL BORE - ASME B16.34

Welded Cover - Flanged Ends according to ASME B16.5

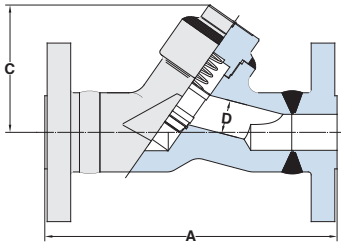

RATINGS: Carbon Steel
 Class 1500 - 3705 psi @100°F

FULL BORE		9-YL940	1/4		3/8		1/2		3/4		1		1 1/4		1 1/2		2	
			mm	in	mm	in	mm	in	mm	in	mm	in	mm	in	mm	in	mm	in
End to End		A	-	-	-	-	216	8.50	229	9.02	254	10.00	-	-	305	12.01	368	14.49
Handwheel		B	-	-	-	-	-	-	-	-	-	-	-	-	-	-	-	-
Open Center to Top		C	-	-	-	-	70	2.76	100	3.94	100	3.94	-	-	120	4.72	140	5.51
Flow Passageway		D	-	-	-	-	11	0.43	15	0.59	19.5	0.77	-	-	31.5	1.24	39	1.54
Approx. Weight		kg/lb	-	-	-	-	5.9	13.0	9.5	20.9	11.3	24.9	-	-	19	41.4	31.9	70.2

25-YL2540

CLASS 2500 PISTON TYPE - FULL BORE - ASME B16.34

Welded Cover - Flanged Ends according to ASME B16.5

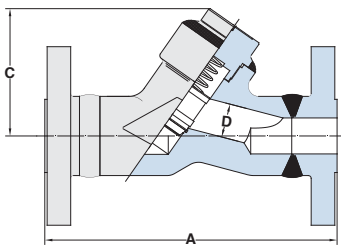

RATINGS: Carbon Steel
 Class 2500 - 6170 psi @100°F

FULL BORE		25-YL2540	1/4		3/8		1/2		3/4		1		1 1/4		1 1/2		2	
			mm	in	mm	in	mm	in	mm	in	mm	in	mm	in	mm	in	mm	in
End to End		A	-	-	-	-	264	10.39	273	10.75	308	12.13	-	-	384	15.12	451	17.76
Handwheel		B	-	-	-	-	-	-	-	-	-	-	-	-	-	-	-	-
Open Center to Top		C	-	-	-	-	115	4.53	120	4.72	150	5.91	-	-	160	6.30	170	6.69
Flow Passageway		D	-	-	-	-	11	0.43	15	0.59	19.5	0.77	-	-	31.5	1.24	39	1.54
Approx. Weight		kg/lb	-	-	-	-	10.6	23.3	11.6	25.5	17.8	39.2	-	-	35.5	78.1	51.9	114.2



Y-PATTERN CHECK VALVES



W1-YB-640 / W3-YB-640 / W6-YB-640

CLASS 150-300-600 PISTON TYPE - FULL BORE - ASME B16.34

Welded Cover - Flanged Ends according to ASME B16.5

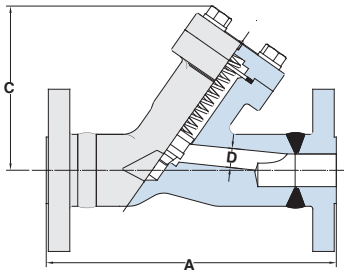

RATINGS: Carbon Steel
Class 150 - 285 psi @100°F - Class 300 - 740 psi @100°F
Class 600 - 1480 psi @100°F

FULL BORE		1/4		3/8		1/2		3/4		1		1 1/4		1 1/2		2		
		mm	in	mm	in	mm	in	mm	in	mm	in	mm	in	mm	in	mm	in	
Class 150	W1-YB-640	-	-	-	-	152	5.98	178	7.01	203	7.99	-	-	229	9.02	267	10.51	
Class 300	W3-YB-640	-	-	-	-	152	5.98	178	7.01	203	7.99	-	-	229	9.02	267	10.51	
Class 600	W6-YB-640	-	-	-	-	165	6.50	190	7.48	216	8.50	-	-	241	9.49	292	11.50	
Handwheel		B		-	-	-	-	-	-	-	-	-	-	-	-	-	-	
Open Center to Top		C		-	-	-	-	101.3	3.99	101.3	3.99	129.5	5.10	-	-	160.8	6.33	
Flow Passageway		D		-	-	-	-	13	0.51	17.5	0.69	22.5	0.89	-	-	35	1.38	
Approx. Weight	Class 150	kg/lb	-	-	-	-	3.3	7.3	3.7	8.1	6.3	13.9	-	-	11.9	26.2	17.1	37.6
	Class 300	kg/lb	-	-	-	-	3.7	8.1	4.5	9.9	7.7	16.9	-	-	15.5	34.1	19.9	43.8
	Class 600	kg/lb	-	-	-	-	3.7	8.1	4.1	9.0	8.1	17.8	-	-	16.7	36.7	22.7	49.9

W9-YB-940

CLASS 1500 PISTON TYPE - FULL BORE - ASME B16.34

Welded Cover - Flanged Ends according to ASME B16.5

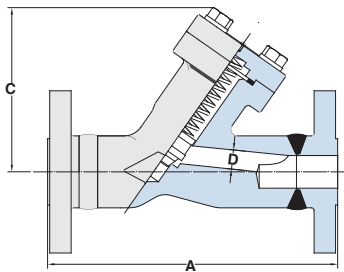

RATINGS: Carbon Steel
Class 1500 - 3705 psi @100°F

FULL BORE		W9-YB-940		1/4		3/8		1/2		3/4		1		1 1/4		1 1/2		2	
		mm	in	mm	in	mm	in	mm	in	mm	in	mm	in	mm	in	mm	in	mm	in
End to End		A		-	-	-	-	216	8.50	229	9.02	254	10.00	-	-	305	12.01	368	14.49
Handwheel		B		-	-	-	-	-	-	-	-	-	-	-	-	-	-	-	-
Open Center to Top		C		-	-	-	-	101.3	3.99	129.5	5.10	129.5	5.10	-	-	193.7	7.63	193.7	7.63
Flow Passageway		D		-	-	-	-	11	0.43	15	0.59	19.5	0.77	-	-	31.5	1.24	39	1.54
Approx. Weight		kg/lb		-	-	-	-	6.1	13.4	10.5	23.1	12.3	27.1	-	-	25	53.9	34.3	75.5

W25-YB-2540

CLASS 2500 PISTON TYPE - FULL BORE - ASME B16.34

Welded Cover - Flanged Ends according to ASME B16.5

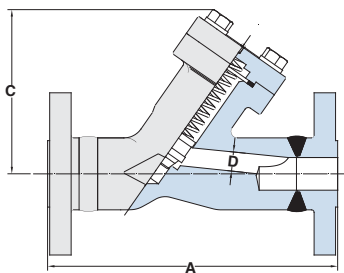

RATINGS: Carbon Steel
Class 2500 - 6170 psi @100°F

FULL BORE		W25-YB-2540		1/4		3/8		1/2		3/4		1		1 1/4		1 1/2		2	
		mm	in	mm	in	mm	in	mm	in	mm	in	mm	in	mm	in	mm	in	mm	in
End to End		A		-	-	-	-	264	10.39	273	10.75	308	12.13	-	-	384	15.12	451	17.76
Handwheel		B		-	-	-	-	-	-	-	-	-	-	-	-	-	-	-	-
Open Center to Top		C		-	-	-	-	129.5	5.10	129.5	5.10	160.8	6.33	-	-	193.7	7.63	286.1	11.26
Flow Passageway		D		-	-	-	-	11	0.43	15	0.59	19.5	0.77	-	-	31.5	1.24	39	1.54
Approx. Weight		kg/lb		-	-	-	-	11.3	24.9	16.5	36.3	20.1	44.2	-	-	37.1	81.6	68.0	149.6



CLASS	DESIGN	CONNECTION	BORE	STANDARD	SCREW & YOKE	ENDS	PAGE	OMB FIG.	VOGT FIG.
800	Piston	-	SB	API 602 ISO 15761	Bolted Cover	NPT&SW Ends	36	840	710
800	Ball	-	SB	API 602 ISO 15761	Bolted Cover	NPT&SW Ends	36	850	B701
800	Swing	-	SB	API 602 ISO 15761	Bolted Cover	NPT&SW Ends	36	860	S701
800	Piston	-	FB	API 602 ISO 15761 BS 5352	Bolted Cover	NPT&SW Ends	36	640	13701
800	Ball	-	FB	API 602 ISO 15761 BS 5352	Bolted Cover	NPT&SW Ends	36	650	B13701
800	Swing	-	FB	API 602 ISO 15761 BS 5352	Bolted Cover	NPT&SW Ends	36	660	N.A.*
800	Piston	-	FB	API 602 ISO 15761	Welded Cover	NPT&SW Ends	36	L840	N.A.*
800	Ball	-	SB	API 602 ISO 15761	Welded Cover	NPT&SW Ends	36	L850	N.A.*
800	Piston	-	SB	API 602 ISO 15761 BS 5352	Welded Cover	NPT&SW Ends	36	L640	N.A.*
800	Ball	-	FB	API 602 ISO 15761 BS 5352	Welded Cover	NPT&SW Ends	36	L650	N.A.*
1500	Piston	-	SB	API 602 ISO 15761	Bolted Cover	NPT&SW Ends	36	R940	15701
1500	Ball	-	SB	API 602 ISO 15761	Bolted Cover	NPT&SW Ends	36	R950	B15701
1500	Swing	-	SB	API 602 ISO 15761	Bolted Cover	NPT&SW Ends	36	R960	S15701
1500	Piston	-	FB	API 602 ISO 15761 BS 5352	Bolted Cover	NPT&SW Ends	36	940	16710
1500	Ball	-	FB	API 602 ISO 15761 BS 5352	Bolted Cover	NPT&SW Ends	36	950	N.A.*
1500	Swing	-	FB	API 602 ISO 15761 BS 5352	Bolted Cover	NPT&SW Ends	36	960	N.A.*
1500	Piston	-	SB	API 602 ISO 15761	Welded Cover	NPT&SW Ends	36	LR940	N.A.*
1500	Ball	-	SB	API 602 ISO 15761	Welded Cover	NPT&SW Ends	36	LR950	N.A.*
1500	Piston	-	FB	API 602 ISO 15761 BS 5352	Welded Cover	NPT&SW Ends	36	L940	N.A.*
1500	Ball	-	FB	API 602 ISO 15761 BS 5352	Welded Cover	NPT&SW Ends	36	L950	N.A.*
1500	Piston	-	FB	BS 5352	Round Bolted Cover	NPT&SW Ends	37	RJ940	N.A.*
1500	Ball	-	FB	BS 5352	Round Bolted Cover	NPT&SW Ends	37	RJ950	N.A.*
1500	Swing	-	FB	BS 5352	Round Bolted Cover	NPT&SW Ends	37	RJ960	N.A.*
2500	Piston	-	FB	ASME B16.34	Welded Cover	SW&BW Ends	37	RJ2540	N.A.*
2500	Ball	-	FB	ASME B16.34	Welded Cover	SW&BW Ends	37	RJ2550	N.A.*
2500	Piston	-	FB	ASME B16.34	Welded Cover	SW&BW Ends	37	L2540	N.A.*
2500	Ball	-	FB	ASME B16.34	Welded Cover	SW&BW Ends	37	L2550	N.A.*
4500	Piston	-	FB	ASME B16.34	Round Bolted Cover	SW&BW Ends	37	RJ4540	N.A.*
4500	Ball	-	FB	ASME B16.34	Round Bolted Cover	SW&BW Ends	37	RJ4550	N.A.*
150	Piston	-	SB	API 602 ISO 15761	Bolted Cover	F Ends	38	F1-840	573
150	Ball	-	SB	API 602 ISO 15761	Bolted Cover	F Ends	38	F1-850	B573
300	Piston	-	SB	API 602 ISO 15761	Bolted Cover	F Ends	38	F3-840	583
300	Ball	-	SB	API 602 ISO 15761	Bolted Cover	F Ends	38	F3-850	B583
600	Piston	-	SB	API 602 ISO 15761	Bolted Cover	F Ends	38	F6-840	593
600	Ball	-	SB	API 602 ISO 15761	Bolted Cover	F Ends	38	F6-850	B593
150	Swing	-	SB	API 602 ISO 15761	Round Bolted Cover	F Ends	38	F1-860	S673
300	Swing	-	SB	API 602 ISO 15761	Round Bolted Cover	F Ends	38	F3-860	S683
600	Swing	-	SB	API 602 ISO 15761	Round Bolted Cover	F Ends	38	F6-860	S693



CHECK VALVES



CLASS	DESIGN	CONNECTION	BORE	STANDARD	SCREW & YOKE	ENDS	PAGE	OMB FIG.	VOGT FIG.
600	Piston	-	FB	API 602 ISO 15761 BS 5352	Bolted Cover	F Ends	38	F6-RJ-840	N.A.*
600	Ball	-	FB	API 602 ISO 15761 BS 5352	Bolted Cover	F Ends	38	F6-RJ-850	N.A.*
600	Swing	-	FB	BS 5352	Round Bolted Cover	F Ends	39	F6-RJ-660	N.A.*
1500	Piston	-	FB	BS 5352	Round Bolted Cover	F Ends	39	F9-RJ-940	N.A.*
1500	Ball	-	FB	BS 5352	Round Bolted Cover	F Ends	39	F9-RJ-950	N.A.*
1500	Swing	-	FB	BS 5352	Round Bolted Cover	F Ends	39	F9-RJ-960	N.A.*
2500	Piston	-	FB	ASME B16.34	Round Bolted Cover	W Ends	39	F25-RJ-2540	N.A.*
2500	Ball	-	FB	ASME B16.34	Round Bolted Cover	W Ends	39	F25-RJ-2550	N.A.*
800	Piston Y Pattern	-	FB	ASME B16.34	Welded Cover	NPT&SW Ends	40	YL640	N.A.*
1500	Piston Y Pattern	-	FB	ASME B16.34	Welded Cover	NPT&SW Ends	40	YL940	N.A.*
1690	Piston Y Pattern	-	FB	ASME B16.34	Welded Cover		40	YL940	
2500	Piston Y Pattern	-	FB	ASME B16.34	Welded Cover	SW&BW Ends	40	YL2540	1610
2680	Piston Y Pattern	-	FB	ASME B16.34	Welded Cover		40	YL2540	
4500	Piston	-	FB	ASME B16.34	Welded Cover	SW&BW Ends	40	YL4540	2610
800	Piston	-	FB	ASME B16.34	Bolted Cover		41	YB640	
1500	Piston	-	FB	ASME B16.34	Bolted Cover		41	YB940	
1690	Piston	-	FB	ASME B16.34	Bolted Cover		41	YB940	
2500	Piston	-	FB	ASME B16.34	Welded Cover		41	YB2540	
2680	Piston	-	FB	ASME B16.34	Welded Cover		41	YB2540	
150	Piston	-	FB	ASME B16.34	Welded Cover		42	1-YL640	
300	Piston	-	FB	ASME B16.34	Welded Cover		42	3-YL640	
600	Piston	-	FB	ASME B16.34	Welded Cover		42	6-YL640	
1500	Piston	-	FB	ASME B16.34	Welded Cover		42	9-YL940	
2500	Piston	-	FB	ASME B16.34	Welded Cover		42	25-YL2540	
150	Piston	-	FB	ASME B16.34	Welded Cover		43	1-YL640-BB	
300	Piston	-	FB	ASME B16.34	Welded Cover		43	3-YL640-BB	
600	Piston	-	FB	ASME B16.34	Welded Cover		43	6-YL640-BB	
1500	Piston	-	FB	ASME B16.34	Welded Cover		43	9-YL940-BB	
2500	Piston	-	FB	ASME B16.34	Welded Cover		43	25-YL2540-BB	
600	Piston	-	FB	ASME B16.34	Welded Cover		44	YB640	
1500	Piston	-	FB	ASME B16.34	Welded Cover		44	YB940	
1690	Piston	-	FB	ASME B16.34	Bolted Cover		44	YB940	
2500	Piston	-	FB	ASME B16.34	Bolted Cover		44	YB2540	
2680	Piston	-	FB	ASME B16.34	Bolted Cover		44	YB2540	

NOTE

SB	STANDARD BORE	F ENDS	INTEGRAL FLANGED ENDS ACCORDING TO ASME B16.5
FB	FULL BORE	W ENDS	FLANGED ENDS ACCORDING TO ASME B16.5
NPT&SW ENDS	THREADED AND SOCKET WELD ENDS ACCORDING TO ASME B16.11	N/A*	FIGURE VALVE IS NOT INCLUDED IN THE BFE OR VOGT CATALOG
SW&BW ENDS	SOCKET WELD ENDS ACCORDING TO ASME B16.11 AND BUTT WELD ENDS ACCORDING TO ASME B16.25		

VOGT SERIES INDICATED ABOVE INCLUSIVE OF MATERIALS



S810/S610

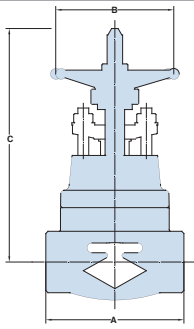

RATINGS: Carbon Steel - 1975 psi @100°F

GATE -CLASS 800 BOLTED BONNET- STANDARD AND FULL BORE - API602

Outside Screw & Yoke - Threaded and Socket Weld Ends

STANDARD PORT	S810	-		1/2		3/4		1		1 1/4		1 1/2		2		-	
FULL BORE	S610	1/4		3/8		1/2		3/4		1		1 1/4		1 1/2		2	
		mm	in	mm	in	mm	in	mm	in	mm	in	mm	in	mm	in	mm	in
End to End	A	90	3.54	90	3.54	90	3.54	110	4.33	127	5.00	155	6.10	170	6.69	210	8.27
Handwheel	B	80	3.15	80	3.15	80	3.15	110	4.33	110	4.33	130	5.12	130	5.12	180	7.09
Open Center to Top	C	145	5.71	145	5.71	155	6.10	185	7.28	210	8.27	250	9.84	270	10.63	335	13.19
Flow Passageway	D	7	0.28	9.6	0.38	14	0.55	18	0.71	24	0.94	29.5	1.16	36.5	1.44	48	1.89
Approx Weight	kg/lb	2.9	6.38	2.9	6.38	2.9	6.4	4.5	9.9	7	15.4	9.5	20.9	13.1	28.82	24.7	54.34

End to End dimensions according to OMB Standards

SR910/S910

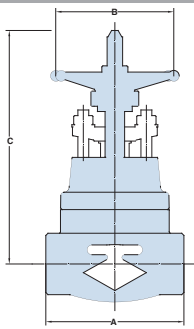

RATINGS: Carbon Steel - 1975 psi @100°F

GATE -CLASS 1500 BOLTED BONNET- STANDARD AND FULL BORE - API602

Outside Screw & Yoke - Threaded and Socket Weld to B16.11

STANDARD BORE	SR910	-		1/2		3/4		1		1 1/4		1 1/2		2		-	
FULL BORE	S910	1/4		3/8		1/2		3/4		1		1 1/4		1 1/2		2	
		mm	in	mm	in	mm	in	mm	in	mm	in	mm	in	mm	in	mm	in
End to End	A	90	3.54	90	3.54	110	4.33	127	5.00	127	5.00	170	6.69	210	8.27	210	8.27
Handwheel	B	80	3.15	80	3.15	110	4.33	110	4.33	130	5.12	130	5.12	180	7.09	180	7.09
Open Center to Top	C	145	5.71	160	6.30	180	7.09	215	8.46	245	9.65	260	10.24	315	12.40	327	12.87
Flow Passageway	D	8	0.31	9.6	0.38	14	0.55	18	0.71	24	0.94	30	1.18	36.5	1.44	40	1.57
Approx Weight	kg/lb	3	6.6	3	6.6	4.8	10.6	6.8	15.0	9.5	20.9	13.1	28.82	23	50.6	25	55

End to End dimensions according to OMB Standards

S830/S630

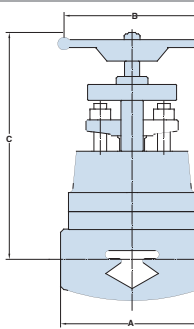

RATINGS: Carbon Steel - 1975 psi @100°F

GLOBE -CLASS 800 BOLTED BONNET- STANDARD AND FULL BORE - API602

Outside Screw & Yoke - Threaded and Socket Weld Ends

STANDARD BORE	S830	-		1/2		3/4		1		1 1/4		1 1/2		2		-	
FULL BORE	S630	1/4		3/8		1/2		3/4		1		1 1/4		1 1/2		2	
		mm	in	mm	in	mm	in	mm	in	mm	in	mm	in	mm	in	mm	in
End to End	A	90	3.54	90	3.54	90	3.54	110	4.33	127	5.00	155	6.10	170	6.69	210	8.3
Handwheel	B	80	3.15	80	3.15	80	3.15	110	4.33	130	5.12	130	5.12	180	7.09	180	7.1
Open Center to Top	C	155	6.10	155	6.10	160	6.30	180	7.09	213	8.39	256	10.08	282	11.10	370	14.57
Flow Passageway	D	7	0.28	9	0.35	13	0.51	17.5	0.69	22.5	0.89	29.5	1.16	35	1.38	45.5	1.79
Approx Weight	kg/lb	2.9	6.38	2.9	6.38	2.9	6.4	4.6	10.1	7.1	15.6	9.6	21.12	13.5	29.7	24.9	54.8

End to End dimensions according to OMB Standards

SR930/S930

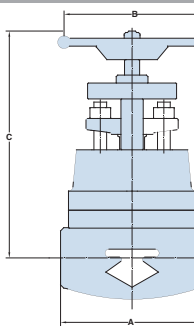

RATINGS: Carbon Steel - 1975 psi @100°F

GLOBE -CLASS 1500 BOLTED BONNET- STANDARD AND FULL BORE - API602

Outside Screw & Yoke - Threaded and Socket Weld Ends

STANDARD BORE	SR930	-		1/2		3/4		1		1 1/4		1 1/2		2		-	
FULL BORE	S930	1/4		3/8		1/2		3/4		1		1 1/4		1 1/2		2	
		mm	in	mm	in	mm	in	mm	in	mm	in	mm	in	mm	in	mm	in
End to End	A	90	3.54	90	3.5	110	4.33	127	5.00	155	6.10	170	6.7	210	8.3	210	8.3
Handwheel	B	80	3.15	80	3.1	110	4.33	130	5.12	130	5.12	130	5.1	180	7.1	180	7.1
Open Center to Top	C	160	6.30	160	6.30	190	7.48	225	8.86	255	10.04	282	11.1	357	14.06	390	15.3
Flow Passageway	D	7.0	0.28	9.0	0.35	13	0.51	17	0.67	21	0.83	28	1.1	33	1.30	37.5	1.5
Approx Weight	kg/lb	3.1	6.8	3.1	6.8	4.6	10.1	7	15.4	9.6	21.1	13.3	29.3	23.2	51.0	25.2	55.4

End to End dimensions according to OMB Standards



NEW: For CRAs closed Die forgings

VALVES IN SPECIAL MATERIALS



S840/S850/S640/S650

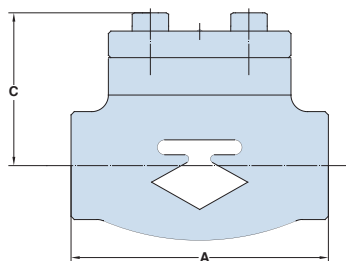

RATINGS: Carbon Steel - 1975 psi @100°F

CLASS 800 PISTON AND BALL TYPE - STANDARD AND FULL PORT- API602

Outside Screw & Yoke - Threaded and Socket Weld Ends

STANDARD BORE	S840	-		1/2		3/4		1		1 1/4		1 1/2		2		-	
	S850																
FULL BORE	S640	1/4		3/8		1/2		3/4		1		1 1/4		1 1/2		2	
	S650																
		mm	in	mm	in	mm	in	mm	in	mm	in	mm	in	mm	in	mm	in
End to End	A	90	3.54	90	3.54	90	3.54	110	4.33	127	5.00	155	6.10	170	6.69	210	8.27
Handwheel	B	-	-	-	-	-	-	-	-	-	-	-	-	-	-	-	-
Open Center to Top	C	53	2.09	53	2.09	55	2.17	70	2.76	80	3.15	92	3.62	102	4.02	136.5	5.37
Flow Passageway	D	7	0.28	9	0.35	13	0.51	17.5	0.69	22.5	0.89	29.5	1.16	35	1.38	45.5	1.79
Approx Weight	kg/lb	1.86	4.092	1.86	4.1	1.86	4.1	3	6.6	5	11	6.5	14.3	9.5	20.9	19.5	42.9

End to End dimensions according to OMB Standards

S860/S660

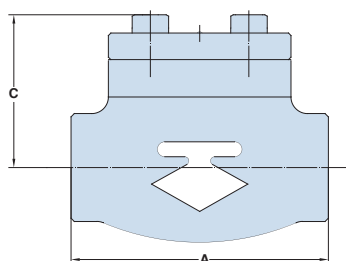

RATINGS: Carbon Steel - 1975 psi @100°F

CLASS 800 SWING TYPE - STANDARD AND FULL PORT- API602

Outside Screw & Yoke - Threaded and Socket Weld to B16.11

STANDARD BORE	S860	-		1/2		3/4		1		1 1/4		1 1/2		2		-	
	S660																
FULL BORE	S660	1/4		3/8		1/2		3/4		1		1 1/4		1 1/2		2	
	S660																
		mm	in	mm	in	mm	in	mm	in	mm	in	mm	in	mm	in	mm	in
End to End	A	90	3.54	90	3.54	90	3.54	110	4.33	127	5.00	127	5.00	127	5.00	150	5.91
Handwheel	B	-	-	-	-	-	-	-	-	-	-	-	-	-	-	-	-
Open Center to Top	C	53	2.09	53	2.09	55	2.17	70	2.76	80	3.15	92	3.62	102	4.02	136.5	5.37
Flow Passageway	D	8	0.31	9.6	0.38	14	0.55	18	0.71	24	0.94	30	1.18	37	1.46	48.5	1.91
Approx Weight	kg/lb	1.86	4.092	1.86	4.1	1.86	4.1	3	6.6	5	11	6	13.2	7	15.4	18	39.6

End to End dimensions according to OMB Standards

S-R940/S-R950/S940/S950

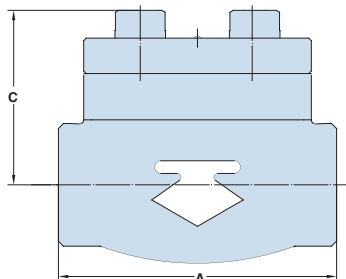

RATINGS: Carbon Steel - 1975 psi @100°F

CLASS 1500 PISTON AND BALL TYPE - STANDARD AND FULL PORT- API602

Bolted Cover - Threaded and Socket Weld Ends

STANDARD BORE	S-R940	-		1/2		3/4		1		1 1/4		1 1/2		2		-	
	S-R950																
FULL BORE	S940	1/4		3/8		1/2		3/4		1		1 1/4		1 1/2		2	
	S950																
		mm	in	mm	in	mm	in	mm	in	mm	in	mm	in	mm	in	mm	in
End to End	A	90	3.54	90	3.54	110	4.33	127	5.00	155	6.10	170	6.69	210	8.27	210	8.27
Handwheel	B	-	-	-	-	-	-	-	-	-	-	-	-	-	-	-	-
Open Center to Top	C	60	2.36	60	2.36	73	2.87	80	3.15	98	3.86	118	4.65	150	5.91	150	5.91
Flow Passageway	D	7	0.28	9	0.35	13	0.51	17.5	0.69	21	0.83	28.0	1.10	33	1.30	37.5	1.48
Approx Weight	kg/lb	2.1	4.62	2.1	4.6	3.6	7.92	5.75	12.65	9.25	20.35	10.3	22.66	20.5	45.1	21.5	47.3

End to End dimensions according to OMB Standards

S-R960/S960

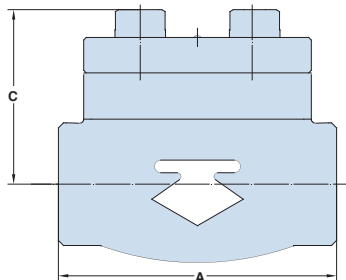

RATINGS: Carbon Steel - 1975 psi @100°F

CLASS 1500 SWING TYPE- STANDARD AND FULL BORE

Bolted Cover - Threaded and Socket Weld Ends

STANDARD BORE	S-R960	-		1/2		3/4		1		1 1/4		1 1/2		2		-	
	S960																
FULL BORE	S960	1/4		3/8		1/2		3/4		1		1 1/4		1 1/2		2	
	S960																
		mm	in	mm	in	mm	in	mm	in	mm	in	mm	in	mm	in	mm	in
End to End	A	90	3.54	90	3.54	110	4.33	127	5.00	127	5.00	127	5.00	210	8.27	210	8.27
Handwheel	B	-	-	-	-	-	-	-	-	-	-	-	-	-	-	-	-
Open Center to Top	C	60	2.36	60	2.36	73	2.87	80	3.15	98	3.86	118	4.65	150	5.91	150	5.91
Flow Passageway	D	8	0.31	9.6	0.38	14	0.55	18	0.71	24	0.94	30	1.18	37	1.46	40	1.57
Approx Weight	kg/lb	2	4.4	2	4.4	3.2	7.04	4.5	9.9	9	19.8	10	22	20	44	20.5	45.1

End to End dimensions according to OMB Standards



Dimensions and weights are subject to change without notice. OMB reserves the rights to make modifications or changes to its production, without any prior notice.

When the customer requires special materials or small amounts of valves, OMB can offer a line of Gate, Globe and Check Valves, from forged bars or blocks.

GATE

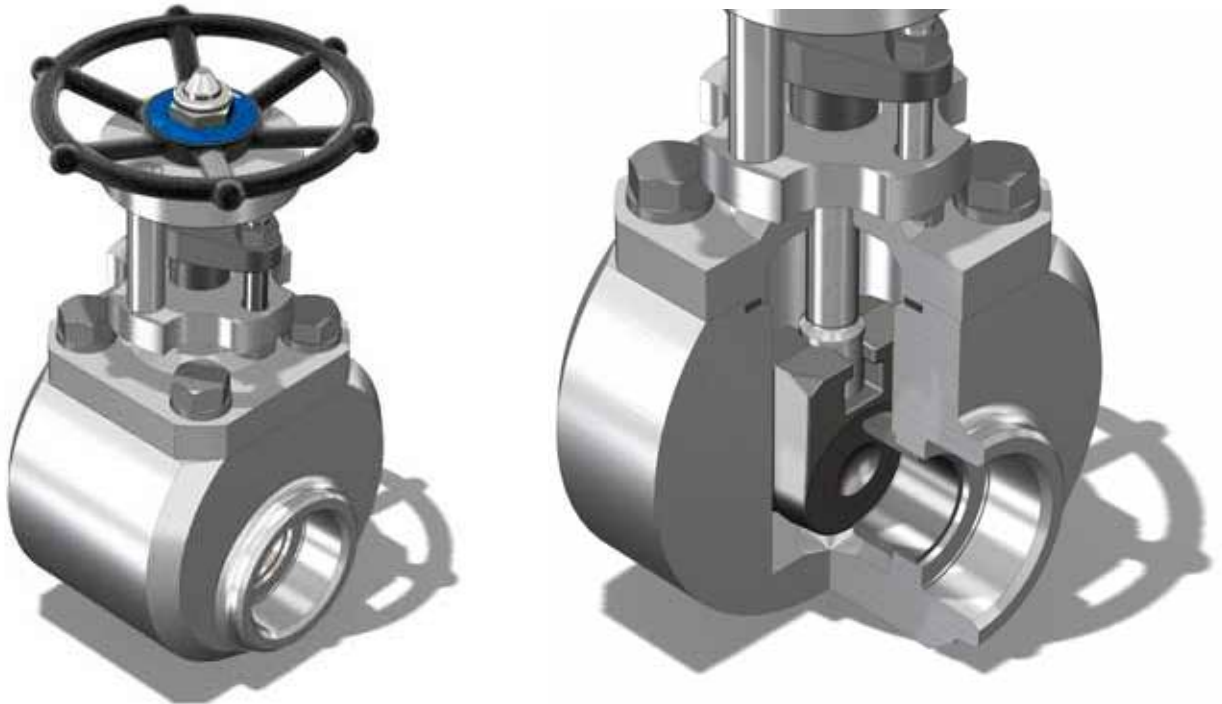

GLOBE

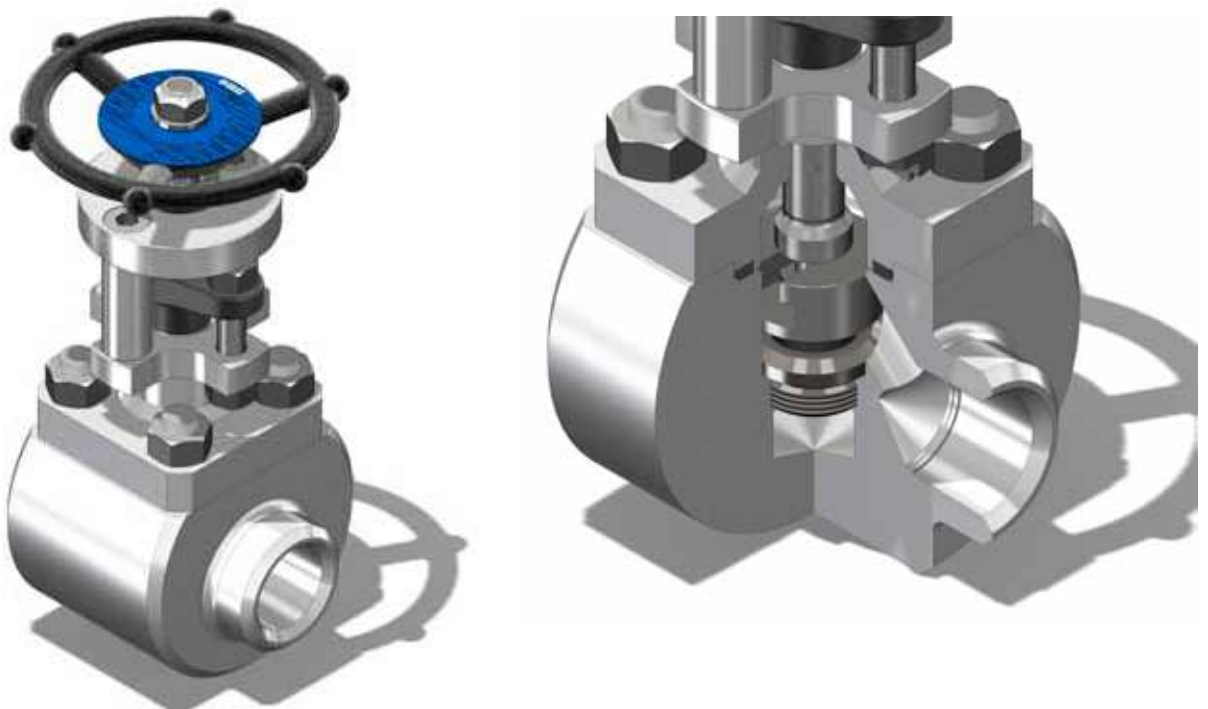

CHECK

BALL AND PISTON CHECK

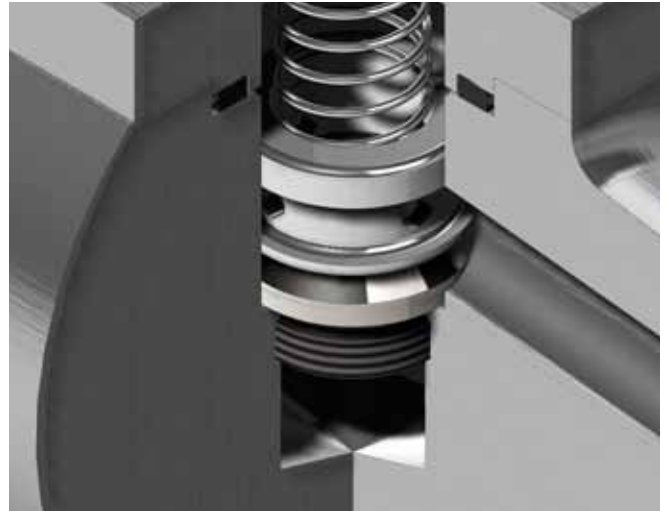

SWING CHECK



F10K-810/F20K-810/F40K-810

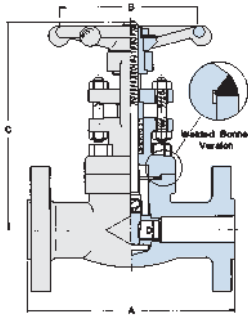

RATINGS: Carbon Steel
 Class 10K: 14 bar @ 29°F - Class 20K: 34 bar @ 29°F
 Class 40K: 68 bar @ 29°F

CLASS 10K-20K-40K GATE VALVES - BOLTED BONNET - JIS 2071:2000

Outside Screw & Yoke - Integral Flanged Ends according to JIS B2238

REGULAR PORT		1/4		3/8		1/2		3/4		1		1 1/4		1 1/2		2	
		mm	in	mm	in	mm	in	mm	in	mm	in	mm	in	mm	in	mm	in
Class 10K	F10K-810	A	-	-	-	108	4.25	117	4.64	127	5.00	-	-	165	6.49	178	7.00
Class 20K	F20K-810	A	-	-	-	140	5.51	152	5.98	165	6.49	-	-	190	7.48	216	8.50
Class 40K	F40K-810	A	-	-	-	165	6.49	190	7.48	216	8.50	-	-	241	9.48	292	11.5
Handwheel		B	-	-	-	80	3.14	80	3.14	110	4.33	-	-	130	5.11	130	5.11
Open Center to Top	Class 10K-20K	C	-	-	-	170	6.69	195	7.67	203	7.99	-	-	243	9.56	262	10.3
	Class 40K	C	-	-	-	148	5.82	163	6.41	178	7.00	-	-	243	9.56	262	10.3
Flow Passageway		D	-	-	-	9.6	0.38	14	0.55	18	0.70	-	-	30	1.18	37	1.45
Approx. Weight	Class 10K	kg/lb	-	-	-	3.4	7.5	3.8	8.3	5.7	12.5	-	-	9.7	21.4	13.2	29.1
	Class 20K	kg/lb	-	-	-	3.9	8.6	5	11.0	6.2	13.6	-	-	12	26.4	16.5	36.3
	Class 40K	kg/lb	-	-	-	4	8.8	5.2	11.4	7.5	16.5	-	-	15	33.0	20.5	45.1

End to end dimension according to JIS B2002

F10K-830/F20K-830/F40K-830

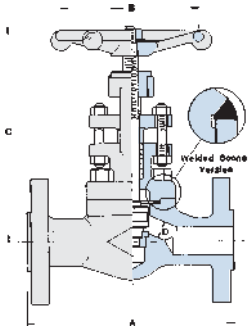

RATINGS: Carbon Steel
 Class 10K: 14 bar @ 29°F - Class 20K: 34 bar @ 29°F
 Class 40K: 68 bar @ 29°F

CLASS 10K-20K-40K GATE VALVES - BOLTED BONNET - JIS 2071:2000

Outside Screw & Yoke - Integral Flanged Ends according to JIS B2238

REGULAR PORT		1/4		3/8		1/2		3/4		1		1 1/4		1 1/2		2	
		mm	in	mm	in	mm	in	mm	in	mm	in	mm	in	mm	in	mm	in
Class 10K	F10K-830	A	-	-	-	108	4.25	117	4.64	127	5.00	-	-	165	6.49	203	7.99
Class 20K	F20K-830	A	-	-	-	152	5.98	178	7.00	203	7.99	-	-	299	9.01	267	10.5
Class 40K	F40K-830	A	-	-	-	165	6.49	190	7.48	216	8.50	-	-	241	9.48	292	11.5
Handwheel		B	-	-	-	80	3.14	80	3.14	110	4.33	-	-	130	5.11	180	7.08
Open Center to Top	Class 10K-20K	C	-	-	-	148	5.82	165	6.49	180	7.08	-	-	248	9.76	257	10.1
	Class 40K	C	-	-	-	170	6.69	197	7.75	205	8.07	-	-	248	9.76	257	10.1
Flow Passageway		D	-	-	-	9	0.35	13	0.51	17.5	0.69	-	-	29.5	1.16	35	1.37
Approx. Weight	Class 10K	kg/lb	-	-	-	3.4	7.5	4	8.8	5.7	12.5	-	-	10	22.0	17.0	37.4
	Class 20K	kg/lb	-	-	-	4	8.8	5	11.0	7.3	16.1	-	-	14	30.8	20.5	45.1
	Class 40K	kg/lb	-	-	-	4.5	9.9	5.5	12.1	7.6	16.7	-	-	15	33.0	21	46.2

End to end dimension according to JIS B2002

F10K-840/ F20K-840/ F40K-840 F10K-850/ F20K-850/ F40K-850

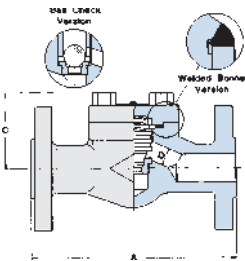

RATINGS: Carbon Steel
 Class 10K: 14 bar @ 29°F - Class 20K: 34 bar @ 29°F
 Class 40K: 68 bar @ 29°F

CLASS 10K-20K-40K PISTON AND BALL VALVES - BOLTED COVER - JIS 2071:2000

Integral Flanged Ends according to JIS B2238

REGULAR PORT		1/4		3/8		1/2		3/4		1		1 1/4		1 1/2		2	
		mm	in	mm	in	mm	in	mm	in	mm	in	mm	in	mm	in	mm	in
Class 10K	PISTON BALL F10K-840 F10K-850	A	-	-	-	108	4.25	117	4.60	127	5.00	-	-	165	6.49	203	7.99
Class 20K	PISTON BALL F20K-840 F20K-850	A	-	-	-	152	5.98	178	7.00	203	7.99	-	-	229	9.01	267	10.5
Class 40K	PISTON BALL F40K-840 F40K-850	A	-	-	-	165	6.49	190	7.48	216	8.50	-	-	241	9.48	292	11.5
Open Center to Top	Class 10K	C	-	-	-	75	2.95	92	3.62	98	3.85	-	-	98	3.85	110	4.33
	Class 20K-40K	C	-	-	-	53	2.08	60	2.36	73	2.87	-	-	98	3.85	110	4.33
Flow Passageway		D	-	-	-	9	0.35	13	0.51	17.5	0.69	-	-	29.5	1.16	35	1.37
Approx. Weight	Class 10K	kg/lb	-	-	-	3.9	6.4	3.2	7.0	4.3	9.5	-	-	6.5	14.3	14.5	31.9
	Class 20K	kg/lb	-	-	-	3.6	7.9	4.2	9.2	6	13.2	-	-	12	26.4	16	35.2
	Class 40K	kg/lb	-	-	-	4.1	9.0	4.7	10.4	6.3	13.8	-	-	13	28.6	17	37.4

End to end dimension according to JIS B2002

F10K-860/F20K-860/F40K-860

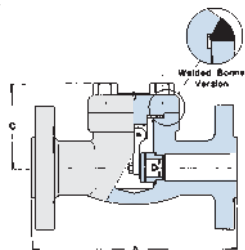

RATINGS: Carbon Steel
 Class 10K: 14 bar @ 29°F - Class 20K: 34 bar @ 29°F
 Class 40K: 68 bar @ 29°F

CLASS 10K-20K-40K SWING VALVES - BOLTED COVER - JIS 2071:2000

Integral Flanged Ends according to JIS B2238

REGULAR PORT		1/4		3/8		1/2		3/4		1		1 1/4		1 1/2		2	
		mm	in	mm	in	mm	in	mm	in	mm	in	mm	in	mm	in	mm	in
Class 10K	F10K-860	A	-	-	-	108	4.25	117	4.60	127	5.00	-	-	165	6.49	203	7.99
Class 20K	F20K-860	A	-	-	-	153	6.02	178	7.00	203	7.99	-	-	229	9.01	267	10.5
Class 40K	F40K-860	A	-	-	-	165	6.49	190	7.48	216	8.50	-	-	241	9.48	292	11.5
Open Center to Top	Class 10K	C	-	-	-	75	2.95	92	3.62	98	3.85	-	-	98	3.85	110	4.33
	Class 20K-40K	C	-	-	-	53	2.08	60	2.36	73	2.87	-	-	98	3.85	10	4.33
Flow Passageway		D	-	-	-	9.6	0.38	14	0.55	18	0.70	-	-	30	1.18	37	1.45
Approx. Weight	Class 10K	kg/lb	-	-	-	2.9	6.4	3.2	7.0	4.3	9.5	-	-	6.5	14.3	14.5	31.9
	Class 20K	kg/lb	-	-	-	3.6	7.9	4.2	9.2	6.1	13.4	-	-	13	28.6	16	35.2
	Class 40K	kg/lb	-	-	-	4.1	9.0	4.7	10.4	6.3	13.8	-	-	13	28.6	17	37.4

End to end dimension according to JIS B2002



F4U-610/F10U-610

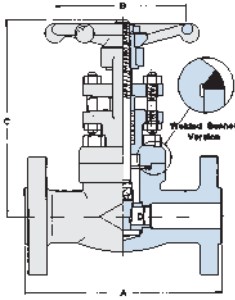

RATINGS: Carbon Steel
DIN PN: 25-40 - 40 bar @ 29°F - DIN PN: 63-100 - 100 bar @ 29°F

CLASS PN25/40/63/100 GATE VALVES - BOLTED BONNET - IN ACCORDANCE TO DIN STANDARD

Outside Screw & Yoke - Integral Flanged Ends according to DIN 5/2636/2637

FULL BORE	PN25 PN100	F4U-610 F10U-610	-		DN 15		DN 20		DN 25		DN 32		DN 40		DN 50	
			mm	in	mm	in	mm	in	mm	in	mm	in	mm	in	mm	in
End to End	PN 25-40	A	-	-	130	5.11	150	5.90	160	6.30	-	-	240	9.44	250	9.84
	PN 63-100	A	-	-	140	5.51	150	5.90	160	6.30	-	-	240	9.44	250	9.84
Handwheel		B	-	-	80	3.14	110	4.33	110	4.33	-	-	130	5.11	180	7.08
Open Center to Top		C	-	-	152	5.98	182	7.16	214	8.42	-	-	270	10.6	333	13.1
Flow Passageway		D	-	-	14	0.55	18	0.70	24	0.94	-	-	37	1.45	47	1.85
Approx. Weight	PN 25-40	kg/lb	-	-	4.4	9.7	6.5	14.3	7.9	17.4	-	-	13	28.6	24.5	53.9
	PN 63-100	kg/lb	-	-	5	11.0	7.4	16.3	9.4	20.7	-	-	15	33.0	27	59.4

End to end dimension according to DIN 3202

PN 63 and PN 100 Welded Flanged

F4U-630/F10U-630

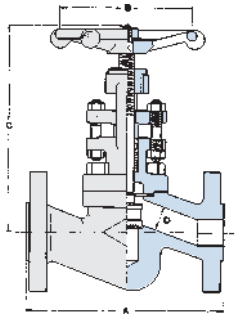

RATINGS: Carbon Steel
DIN PN: 25-40 - 40 bar @ 29°F - DIN PN: 63-100 - 100 bar @ 29°F

CLASS PN25/40/63/100 GLOBE VALVES - BOLTED BONNET - IN ACCORDANCE TO DIN STANDARD

Outside Screw & Yoke - Integral Flanged Ends according to DIN 2634/2635/2636/2637

FULL BORE	PN25 PN100	F4U-630 F10U-630	-		DN 15		DN 20		DN 25		DN 32		DN 40		DN 50	
			mm	in	mm	in	mm	in	mm	in	mm	in	mm	in	mm	in
End to End	PN 25-40	A	-	-	130	5.11	150	5.90	160	6.30	-	-	200	7.87	230	9.05
	PN 63-100	A	-	-	210	8.26	230	9.05	230	9.05	-	-	260	10.2	300	11.8
Handwheel		B	-	-	80	3.14	110	4.33	110	4.33	-	-	130	5.11	180	7.08
Open Center to Top		C	-	-	180	7.08	185	7.28	215	8.46	-	-	260	10.2	230	9.0
Flow Passageway		D	-	-	15	0.559	19	0.75	24	0.95	-	-	38	1.49	50	1.96
Approx. Weight	PN 25-40	kg/lb	-	-	5	11.0	6.5	14.3	8.5	18.7	-	-	14	30.8	24.5	53.9
	PN 63-100	kg/lb	-	-	6.5	14.3	8.0	17.6	10	22.0	-	-	16.5	36.3	30	66.0

End to end dimension according to DIN 3202

PN 63 and PN 100 Welded Flanged

F4U-640/F10U-640

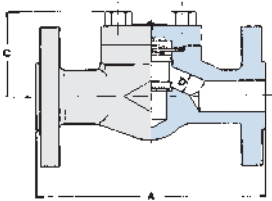

RATINGS: Carbon Steel
DIN PN: 25-40 - 40 bar @ 29°F - DIN PN: 63-100 - 100 bar @ 29°F

CLASS PN25/40/63/100 PISTON CHECK - BOLTED BONNET - IN ACCORDANCE TO DIN STANDARD

Integral Flanged Ends according to DIN 2634/2635/2636/2637

FULL BORE	PN25 PN100	F4U-640 F10U-640	-		DN 15		DN 20		DN 25		DN 32		DN 40		DN 50	
			mm	in	mm	in	mm	in	mm	in	mm	in	mm	in	mm	in
End to End	PN 25-40	A	-	-	130	5.11	150	5.90	160	6.30	-	-	200	7.87	230	9.05
	PN 63-100	A	-	-	210	8.26	230	9.05	230	9.05	-	-	260	10.2	300	11.8
Open Center to Top		C	-	-	85	3.34	90	3.54	95	3.74	-	-	135	5.31	120	4.72
Flow Passageway		D	-	-	15	0.59	19	0.75	24	0.95	-	-	38	1.49	50	1.96
Approx. Weight	PN 25-40	kg/lb	-	-	3.5	7.7	4.0	8.8	6.0	13.2	-	-	11	24.2	16	35.2
	PN 63-100	kg/lb	-	-	5	11.0	5.5	12.1	7.5	16.5	-	-	13.5	29.7	21.5	47.3

End to end dimension according to DIN 3202

PN 63 and PN 100 Welded Flanged

25-Y2540

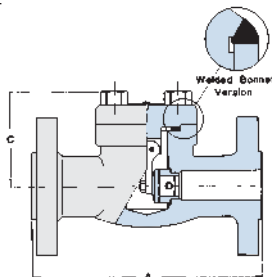

RATINGS: Carbon Steel
DIN PN: 25-40 - 40 bar @ 29°F - DIN PN: 63-100 - 100 bar @ 29°F

CLASS PN25/40/63/100 PISTON CHECK - BOLTED COVER - IN ACCORDANCE TO DIN STANDARD

Integral Flanged Ends according to DIN 2634/2635/2636/2637

FULL BORE	PN25 PN100	F4U-640 F10U-640	-		DN 15		DN 20		DN 25		DN 32		DN 40		DN 50	
			mm	in	mm	in	mm	in	mm	in	mm	in	mm	in	mm	in
End to End	PN 25-40	A	-	-	130	5.11	150	5.90	160	6.30	-	-	200	7.87	230	9.05
	PN 63-100	A	-	-	210	8.26	230	9.05	230	9.05	-	-	260	10.2	300	11.8
Open Center to Top		C	-	-	85	3.34	90	3.54	95	3.74	-	-	135	5.31	120	4.72
Flow Passageway		D	-	-	14	0.55	18	0.70	24	0.95	-	-	37	1.45	47	1.85
Approx. Weight	PN 25-40	kg/lb	-	-	3.2	7.0	3.5	7.7	5.5	12.1	-	-	10.5	23.1	15	33.0
	PN 63-100	kg/lb	-	-	4.7	10.3	5	11.0	7	15.4	-	-	13	28.6	20.5	45.1

End to end dimension according to DIN 3202

PN 63 and PN 100 Welded Flanged

At printing time the list of ISO standards for our industry can be summarized in the following table. We list the key API and ASME standards covering our industry as well, to which we refer in some of the following pages.

DESIGN AND MANUFACTURING STANDARDS		
ISO	API/ASME/BS	DESCRIPTION
ISO 5208:2008		Industrial valves – Pressure testing of metallic valves
ISO 5752:1982		Metal valves for use in flanged pipe systems – Face-to-face and centre-to-face dimensions
ISO 7121:2006		Flanged steel ball valves
ISO 10423:2009	API 6A	Specification for Wellhead and Christmas Tree Equipment
ISO 10434:2004		Bolted bonnet steel gate valves for the petroleum, petrochemical and allied industries
ISO 10497:2004	API 607	Testing of valves - Fire type-testing requirements (Fire Test for Soft-Seated Quarter-Turn Valves)
ISO 14313:2007	API 6D	Specification for Pipeline Valves
ISO 15156	NACE MR0175	NACE MR0175, Petroleum and natural gas industries—Materials for use in H ₂ S-containing environments in oil and gas production
ISO 15761:2002	API 602 (including former BS5352)	Steel gate, globe and check valves for sizes DN 100 and smaller, for the petroleum and natural gas industries
ISO 15848-1:2006		Industrial valves — Measurement, test and qualification procedures for fugitive emission Part 1: Classification system and qualification procedures for type testing of valves
ISO 17292:2004		Metal ball valves for petroleum, petrochemical and aligned industries
	API 598	Valve Inspection and Testing
	API 600	Steel Gate Valves
	API 602	Compact Carbon Steel Gate Valves
	API 603	Cast, Corrosion Resistant Gate Valves
	API 608	Metal Ball Valves—Flanged, Threaded and Butt-Welding Ends (150&300)
	API 17D	Specification for Subsea Wellhead and Christmas Tree Equipment
	API 6FA	Specification for Fire Test for Valves
	API 622	Type Testing of Process Valve Packing for Fugitive Emissions
	ASME B16.34	Valves-Flanged threaded and welding end
	ASME B16.10	Face-to-Face and End-to-End Dimensions of Valves
	ASME B16.5	Pipe Flanges and Flanged Fittings
	ASME B16.25	Buttwelding ends
	ASME B16.11	Forged Fittings, Socket-Welding and Threaded
ISO 14723:2009	API 6DSS	Specification for Subsea Pipeline Valves
ISO 15848-2:2006		Industrial valves - Measurement test and qualification procedures for fugitive emissions - Part 2: production acceptance test of valves
	ASME B31.3	Process piping



Material Sources & Traceability

OMB has extensively invested in dies made of a wide variety of materials, from common carbon steels to the most exotics alloys, for all valve sizes and pressure Classes. Additionally, OMB uses only Made-in-Italy forgings (for all the products) and ISO9001* certified suppliers.



Our valves are always supplied with the forging plant certification code 3.1. We keep track of all the certificates on our online database (searchable at www.ombvalves.com) issued over the past fifteen (15) years.

Material & Valves Testing Facilities

OMB has the infrastructure to perform in-house nondestructive examinations (NDE) with the following analysis techniques: Ultrasonic Testing (UT), Magnetic particle Inspection (MPI) and Die Penetrant Inspection (DPI) Computer-assisted chemical analysis as Direct Reading Emission (with Spectrometer), Hardness Test* and Ferrite Content, are also available.

In addition, packing emission tests in accordance with the latest ISO requirements: helium gas, cryogenic, vacuum and other functional testing, can be carried out at our laboratories.

Note: Each valve is hydraulically, seat leakage and functionally tested

OMB PROCEDURE CODE	DESCRIPTION	NORMATIVE REFERENCES
PCQ00101/PCQ00102	Hydraulic Test Procedure API 598 valves	API 598; BS EN 12266-1
PCQ01601	Hydraulic Test Procedure API 6D ball valves	API 6D
PCQ03601	Hydraulic Test procedure according to API6A	API 6A / ISO 10423
PCQ00201	PMI test	ASTM Code
PCQ00401	Die penetrant examination procedure	ASME B16.34; ASTM E165; OMB Q.A. Manual; ASME BPV; ASTM E1418
PCQ00701	Painting Procedure	ISO 8501; ISO 8503; ISO 19840; SSPC SP-1
PCQ00801	UT for forgings	ASTM A388; ASNT SNT TC-IA; ASME B16.34
PCQ00901/PCQ00902	Gas test procedure GGC and ball valves	ASME V; ASME B16.34; API598; API6D; ISO 5208
PCQ01001	Packing procedure	API 602; API 6D/ISO14313
PCQ01301/PCQ01302	Cryogenic test procedure according to BS 6364	BS 6364; API 598; ASME B16.34
PCQ01303	Cryogenic test procedure according to MESG SPE 77/200	BS 6364; API 598; ASME B16.34; MESG SPE 77/312 ; MESG SPE 77/200
PCQ01304/PCQ01305	Cryogenic test procedure according to Total GS EP PVV 150	GS EP PVV 150; API 598; API 6D; ASME B16.34
PCQ02001	Hardness test procedure	NACE MR0175 / ISO 15156; ASTM A370; ASME BPV
PCQ02501	Functional Test Procedure	API 598; API 6D; BS EN ISO 12266 - 2
PCQ03001	Ferrite test with ferritoscope	
PCQ03201	FE production testing (Shell MESG SPE 77-312)	SPE 77/312; SPE 77/300; ISO 15848-2
PCQ03301	FE production testing ISO 15848-2	ISO 15848-2:2006; ISO 5208; API 598; ASME B16.34
PCQ03901	API6DSS	API6DSS / ISO 14723; ASME B16.34; ISO 5208

Special Design

On top of the complete range of valves covered by ISO15761/API602 standards, we manufacture special gate, globe and check valves to meet specific requirements for various services and process conditions:

- Bellows Seal valves
- Cryogenic and Low Temperature valves
- High Temperature / High Pressure service valves
- “Y” -Pattern Globe and Check valves
- Alkylation Service
- Extended Bonnet / Lantern Ring Vacuum service valves
- Chlorine service valves
- Urea service valves
- Instrumentation – Needle valves
- Valves with Soft Seat Inserts
- Self Closing (Spring Operated) Globe valves
- Angle Valves

Special Service

ISO15761/API602 valves are designed for general use in the Petroleum and Natural Gas industries. In the event that special application valves are requested; design, material selection, manufacturing and inspection procedures may vary in order to address the specific requirements of the process. OMB publishes a set of guidelines for special services based on its experience and different industry standards, with the identification of particular requirements for each application.

SPECIAL SERVICE APPLICATIONS	
SERVICE	NOTE
Bellows Seal	Bellows seal valves have been developed and tested according the EPA-API SV - 001 ANSI and BS specifications.
Hydrogen	Special heat treatment and gas testing procedures.
Oxygen	Special procedures guarantee a perfect cleanliness of the valve and protection during shipping.
Vacuum	Close manufacturing tolerances and special extended packingbox and SV - 004 lantern ring assure tight sealing. Test performed at 10 (-4) bar.
Actuator	Pneumatic, Hydraulic and Electric actuators are available upon customer request.
Chlorine	Special degreasing procedure, dry-air testing, packing in moisture absorbing SV - 006 materials, as suggested by the Chlorine Institute.
Steam	Special procedures cover all the applications for steam service.
Cryogenic	Complete range of special designs and testing procedures for service SV - 008 down to -521F/-196C.
Sour Oil and Gas	Valves are manufactured strictly in accordance with NACE specifications MR-01-75
High Temperature	Special grade of steel for use up to 1500F/800C.
Alkylation	Special procedures to select materials and assure a perfect cleanliness of valves.

Without prior notice OMB reserves the right to make modifications or changes to its production.



OMB offers a wide variety of Bellows Seal valves, including the innovative Eco-L-Valves®. Our bellows seal valves are built in strict accordance with the API602/ISO15761 standards specifications, prototype tested to ensure long life requirements, manufactured and inspected with the newest technologies and materials. A dedicated catalog introduces our product line available for download at our website www.ombvalves.com



Gate & Globe

- ASME Class: 150, 300, 600, 800, 1500
- Closed die forging
- Valve construction: 3 pieces, body/ext/bonnet
- Body/bonnet construction: full pen. welding or bolted
- Bellows unit: design with transition pieces
- Globe valves disc design: separated from bellows



Gate & Globe

- ASME Class: 2500
- Closed die forging
- Valve construction: 3 pieces, body/ext/bonnet
- Body/bonnet construction: full pen. welding or bolted
- Bellows unit: design with transition pieces
- Globe valves disc design: separated from bellows



Globe Y Pattern

- ASME Class: 150, 300, 600, 800, 1500, 2500
- Closed die forging
- Valve construction: 3 pieces, body/ext/bonnet
- Body/bonnet construction: full pen. welding or bolted
- Bellows unit: design with transition pieces
- Globe valves disc design: separated from bellows



Gate & Globe

- ASME Class: 150, 300, 600, 1500
- Castings
- Valve construction: 3 pieces, body/ext/bonnet
- Body/bonnet construction: full pen. welding or bolted
- Bellows unit: design with transition pieces
- Globe valves disc design: separated from bellows



Eco-L-Valve®

- ASME Class: 150, 300, 600, 800, 1500
- Closed Die Forging
- Valve construction: 2 pieces, body/bonnet
- Body/bonnet construction: full pen. welding or bolted
- Bellows unit: design with transition pieces
- Disc integral with bellows



Eco-L-Valve® Y Pattern

- ASME Class: 150, 300, 600, 800
- Closed Die Forging
- Valve construction: 2 pieces, body/bonnet
- Body/bonnet construction: full pen. welding or bolted
- Bellows unit: design with transition pieces
- Disc integral with bellows



OMB's valves are manufactured in a wide variety of materials, supplied by the best available steel mills and forged with reliable and advance by experienced and well known forging plants. All materials' chemical composition and mechanical properties can be certified.

MATERIAL GROUP	COMMON NAME	OMB code	NOMINAL TYPE	UNS	FORGING SPEC. (ASTM)	CASTING SPEC. EQUIVALENT	DIN	DIN W. No	APPLICATION NOTES
Carbon Steel	CS	A105N	C-Mn-Fe	K03504	A105N	A216-WCB	C22.8	1.0460	General non-corrosive service from -20F(-29C) to 800F(427C)
Low temperature Carbon Steel	LTCS	LF1			A350-LF1				
	LTCS	LF2	C-Mn Si	K03011	A350-LF2	A352-LCA A352-LCB A352-LCC	TSTE 355	1.0566	General non-corrosive service from -50F(-46C) to 650F(340C), LF2 to 800F(427C).
	LTCS	LF3	3.1/2Ni	K32025	A350-LF3	A352-LC3	10Ni14	1.5637	-150F(-101C) to 650F(340C)
	LTCS	LF6	C-Mn-Si-V		A350-LF6				higher impact test value at low temp than LF2
Low Alloy Steel	Moly Steel	F1	C-1/2Mo	K12822	A182-F1	A217-WC1	15MO3	1.5415	Up to 875F(468C)
	High Alloy Steel	Alloy Steel Chrome Moly	F11 cI2	1 1/4Cr-1/2Mo	K11572	A182-F11	A217-WC6	13CRMO44	1.7335
F22 cI3			2.1/4Cr-1Mo	K21590	A182-F22	A217-WC9	10CRM0910	1.7380	Up to 1100F(593C), HP steam
F5			5Cr-1/2Mo	K41545	A182-F5	A217-C5	12CRM0195	1.7362	High temp refinery service
F9			9Cr-1Mo	K90941	A182-F9	A217-C12	X 12 CrMo 9 1	1.7386	High temp erosive refinery service
F91			9Cr-1Mo-V	K90901	A182-F91	A217-C12A	X 10 CrMoVnB 9 1	1.4903	High pressure steam
Stainless Steel	Austenitic S Steel 300 series S Steel	F304	18Cr-8Ni	S30400	A182-F304	A351-CF8	DIN X5CrNi 18 9	1.4301	0.04% min. carbon for temp.>1000F(538C)
		F304L	18Cr-8Ni (C 0.03)	S30403	A182-F304L	A351-CF3	X 2 CrNi 19 11	1.4306	Up to 800F(427C)
		F304H	18Cr-8Ni	S30409	A182-F304H	A351-CF8	n/a	n/a	
		F310	25 Cr-20 Ni		A182-F310	A351-CK20			
		F316	16Cr-12Ni-2Mo (C 0.08)	S31600	A182-F316	A351-CF8M	DIN X5CrNiMo 18 10	1.4401	0.04% min. carbon for temp.>1000F(538C)
		F316L	16Cr-12Ni-2Mo (C 0.03)	S31603	A182-F316L	A351-CF3M	X 5 CrNiMo 17 12 2	1.4404	Up to 800F(427C)
		F316H	16Cr-12Ni-2Mo	S31609	A182-F316H	A351-CF8M	n/a	n/a	
		F316Ti		S31635	A182-F316Ti		X 6 CrNiMoTi 17 12 2	1.4571	
		F321	18Cr-10Ni-Ti	S32100	A182-F321		X 6 CrNiTi 18 10	1.4541	0.04% min. carbon (grade F321H) and heat treat at 2000F(1100C) for service temps.>1000F(538C)
		F321H	18Cr-10Ni-Ti	S32109	A182-F321H		n/a	n/a	
		F347	18Cr-10Ni-Cb(Nb)	S34700	A182-F347	A351-CF8C	DIN 8556	1.4550	0.04% min. carbon (grade F347H) and heat treat at 2000F(1100C) for service temps.>1000F(538C)
		F347H	18Cr-10Ni-Cb(Nb)	S34709	A182-F347H	A351-CF8C	n/a	n/a	
		F317L		S31703	A182-F317L	A351-CG3M	X 2 CrNiMo 18 16 4	1.4438	
Martensitic stainless steel	F6a-13Cr - 410	F6	13Cr	S41000	A182 F6	A351-CA15			13% Cr steel (trim material)
	F6NM	F6NM		S41500	A182 F6NM	A351-CA6NM	X 3 CrNiMo 13-4	1.4313	13% Cr steel with excellent low temperature impact properties and corrosion resistance
	17-4-PH	17-4-PH		S17400	A564 UNS S17400	ASTM A494 CU5MCuC	X 5 CrNiCuNb 16-4	1.4542	
Super Austenitic Steel	Super Austenitic 6Mo	F44	20Cr-18Ni-6Mo	S31254	A182-F44	A351-CK3MCuN	X 1 CrNiMoCuN 20 18 7	1.4547	service to 600F(316C)
		904L	44Fe-25Ni-21Cr-Mo	N08904	B649-N08904		Z2 NCDU 25-20	1.4539	
		926		N08926	B649-N08926		X1NiCrMoCuN 25-20-7	1.4529	virtual immunity under practical conditions to chloride-ion stress-corrosion cracking
									service to 600F(316C)
NiCrMo S Steel	Alloy 20	ALLOY 20	28Ni-19Cr-Cu-Mo	N08020	A182-F20	A351-CN7M	DIN 1.4500	2.4660	
	Alloy 28	ALLOY 28		N08028				1.4563	nickel based alloy (Ni/Fe/Cr) with good corrosion resistance and a high range of mechanical strength. The alloy was originally developed for use in the manufacture of phosphoric acid.
Duplex Steel	Duplex 2205	F51	22Cr-5Ni-3Mo-N	S31803 S32205	A182-F51	A890-Grade 4A (UNS J92205) - A995 CD3MN	X2CrNiMoN22 5 3	1.4462	service to 600F(316C) -The original S31803 UNS designation has been supplemented by S32205 which has higher minimum N, Cr, and Mo.
Super Duplex Steel	Super Duplex 2507	F53	25Cr-7Ni-4Mo-N	S32750	A182-F53	A351-CD4Mcu A890 5A	X2CrNiMoN25 7 4	1.4410	service to 600F(316C)
	Super Duplex	F55	25Cr-7Ni-3.5Mo-N-Cu-V	S32760	A182-F55	A351 GR CD3MWCuN	X2CrNiMoCuWN25.7.4	1.4501	
	Ferrallium 255	255		S32550		ASTM A487 gr 4C	n/a	n/a	
Nickel	Nickel 200	NICKEL	99/95Ni	N02200	B564-N02200	A494-CZ-100	NW2200	1.7740	service to 600F(316C)
Nickel-Iron Alloy	Incoloy 800	ALLOY 800	33Ni-42Fe-21Cr	N08800	B564-N08800	A351-CT15C	X 10 NiCrAlTi 32 20	1.4876	
	Incoloy 800H	ALLOY 800H		N08810	B564-N08810				
	Incoloy 800HT	ALLOY 800HT		N08811	B564-N08811				
	Incoloy 825	ALLOY 825	42Ni-21.5Cr-3Mo-2.3Cu	N08825	B425-N08825	A494-CU5MCuC	NiCr 21 Mo	2.4858	service to 1000F(538C)
Nickel Superalloys	Inconel 600	ALLOY 600	72Ni-15Cr-8Fe	N06600	B564-N06600	A494-CY40	NiCr 15 Fe	2.4816	
	Inconel 625	ALLOY 625	60Ni-22Cr-9Mo-3.5Cb	N06625	B564-N06625*	A494-CW-6MC	DIN 17744	2.4856	*Difficult to forge in close Die
	Inconel 718	ALLOY 718	52.5Ni-19Cr-3Mo	N07718	B637-N07718			2.4668	Alloy 718 is a precipitation hardenable nickel-based alloy designed to display exceptionally high yield, tensile and creep-rupture properties at temperatures up to 1300°F (704°C).
	Hastelloy B2	ALLOY B2	65Ni-28Mo-2Fe	N10665	B564-N10665*				solid solution strengthened, nickel-molybdenum alloy, with significant resistance to reducing environments like hydrogen chloride gas, and sulfuric, acetic and phosphoric acids
	Hastelloy C-276	ALLOY C276	54Ni-15Cr-16Mo	N10276	B564-N10276*	A494-CW-2M	NiMo 16 Cr 15 W	2.4819	*Difficult to forge in close Die
	Hastelloy C-22	ALLOY C-22		N06022	B462-N06022			2.4602	austenitic nickel-chromium-molybdenum-tungsten alloy with enhanced resistance to pitting, crevice corrosion and stress corrosion cracking
Nickel-Copper	Monel 400	MONEL	67Ni-30Cu	N04400	B564-N04400	A494-M35-1	DIN 17730	2.4365	
	Monel K500	MONEL500		N05500	B865-N05500			n/a	Available as well in 500 grade
Titanium	Titanium	TITANIUM	98Ti	R50400	B381-F2	B367-C2	Ti 2	3.7035	



The following tables show OMB's standard combination of trim (stem, disc or wedge, seat) composition. Different composition and material combinations are available upon request.

OMB'S STANDARD TRIM COMBINATIONS						
API TRIM NO	NOMINAL TRIM	OMB DESCR.	STEAM	DISC/WEDGE	SEAT	MIN HARDNESS (BRINELL)
1	F6	F6	410 (13Cr)	F6 (13Cr)	410 (13Cr)	250
2	304	304	304 (18Cr-8Ni)	304 (18Cr-8Ni)	304 (18Cr-8Ni)	not specified
3	-	-	(25Cr-20Ni)	310 (25Cr-20Ni)	310 (25Cr-20Ni)	not specified
4	-	-	410 (13Cr)	F6 (13Cr)	F6 (13Cr)	750
5	Hardfaced	F6HF	410 (13Cr)	F6 + St Gr6 (CoCr Alloy)	410 + St Gr6 (CoCr Alloy)	350
5A	-	-	410 (13Cr)	F6+Hardf. NiCr Alloy	410+Hardf. NiCr Alloy	350
6	-	-	410 (13Cr)	F6 (13CR)	Alloy 400 (NiCu Alloy)	250/175
7	-	-	410 (13Cr)	F6 (13CR)	F6 (13Cr)	250/750
8	F6 and Hardfaced	F6HFS	410 (13Cr)	F6 (13CR)	410 + St Gr6 (CoCr Alloy)	250/350
8A	-	-	410 (13Cr)	F6 (13CR)	410 Hardf. Nicr Alloy	250/350
9	Alloy 400	Alloy 400	Alloy 400 (NiCu Alloy)	Alloy 400 (NiCu Alloy)	Alloy 400 (NiCu Alloy)	not specified
10	316	316	316 (18Cr-8Ni-Mo)	316 (18Cr-8Ni-Mo)	316 (18Cr-8Ni-Mo)	not specified
11	Alloy 400 and Hardfaced	Alloy 400 HFS	Alloy 400 (NiCu Alloy)	Alloy 400 (NiCu Alloy)	Alloy 400 St Gr6	350
11A	-	-	Alloy 400 (NiCu Alloy)	Alloy 400 (NiCu Alloy)	Alloy 400 Hardif. NiCrA	3350
12	316 and Hardfaced	316HFS	316 (18Cr-8Ni-Mo)	316 (18Cr-8Ni-Mo)	316 + St. Gr6	350
12A	-	-	316 (18Cr-8Ni-Mo)	316 (18Cr-8Ni-Mo)	316 Hardf. NiCr Alloy	350
13	Alloy 20	Alloy 20	Alloy 20 (19Cr-29Ni)	Alloy 20 (19Cr-29Ni)	Alloy 20 (19Cr-29Ni)	not specified
14	Alloy 20 and Hardfaced	Alloy 20HFS	Alloy 20 (19Cr-29Ni)	Alloy 20 (19Cr-29Ni)	Alloy 20 St Gr6	350
14A	-	-	Alloy 20 (19Cr-29Ni)	Alloy 20 (19Cr-29Ni)	Alloy 20 Hardf. NiCr Alloy	350
15	Hardfaced (304)	304-HF	304 (18Cr-8Ni)	304 + St Gr6	304 + St Gr6	350
16	Hardfaced (316)	316-HF	-	316 + St Gr6	316 + St Gr6	350
17	Hardfaced (347)	347-HF	-	347 + St Gr6	347 + St Gr6	350
18	Hardfaced Alloy 20 HF	Alloy 20 HF	Alloy 20 (19Cr-29Ni)	Alloy 20 + St Gr6	Alloy 20 + St Gr6	350
n/a	Alloy 625	Alloy 625	Alloy 625	Alloy 625	Alloy 625	-

OMB TRIM MATERIAL GRADES						
OMB	UNS	TYPE	Grade (forged)	ASTM wrought	DIN	DIN W No
F6	UNS S41000	13Cr	ASTM A182 F6a	A276-410	DIN X12Cr13	1.4006
304	UNS S30400	18-8 Cr-Ni	ASTM A182 F304	A276-304	DIN X5CrNi 18 10	1.4301
316	UNS S31600	18-8 Cr-Ni (18-10-2)	ASTM A182 F316	A276-316	DIN X5CrNiMo 18 10	1.4401
321	UNS S32100	18 Cr-10 Ni-Ti	ASTM A182 F321	A276-321	DIN X6CrNiTi 18 10	1.4541
347	UNS S34700	18 Cr-10 Ni-Cb	ASTM A182 F347	A276-347	DIN X6CrNiNb18 10	1.4550
NICKEL ALLOY 400	UNS N04400	67Ni-30Cu	ASTM B564-N04400	B164-N04400	DIN 17743	2.4360
ALLOY 20	UNS N08020	28Ni-19Cr-Cu-Mo	ASTM A182-F20	ASTM B473	DIN 14500	2.4660
ALLOY 625	UNS N06625	60Ni-22Cr-9Mo-3.5Cb	ASTM B564-N06625	ASTM B564-N06625	DIN 17361	2.4865
C276	UNS N10276	54Ni-15Cr-16Mo	ASTM B564-N10276	ASTM B574-N10276	DIN NiMo 16 Cr 15 W	2.4819
17/4PH	UNS S17400	0Cr17Ni4Cu4Nb	ASTM A705 UNS S17400	ASTM A564 UNS S17400	X5CrNiCuNb17-4-4	1.4548
St. Gr6	UNS R30006	Co Cr-A	AMS 5894		Stellite(R) Gr6	



CORROSION MEDIA					
	Carbon Steel	Stainless Steel 304	Stainless Steel 316	Inconel	Monel
Acetate Solvents, Crude	D	A	A	A	B
Acetate Solvents, Pure	C	A	A	A	A
Acetic Acid, 95%	D	B	A	A	A
Acetic Anhydride, Boiling	D	B	A	A	A
Acetone	B	A	A	A	A
Alcohols	B	A	A	A	A
Amines	B	A	A	A	A
Ammonia, Anhydrous	B	A	A	A	A
Ammonium Hydroxide, Hot	B	A	A	A	D
Ammonium Nitrate	B	A	A	A	C
Aniline Hydrochloride	D	D	C	B	B
Antimony Trichloride	D	D	C	B	B
Asphalt	B	A	A	A	A
Barium Chloride, 5%	C	A	A	A	A
Barium Hydroxide	C	A	A	A	A
Barium Nitrate	C	A	A	B	C
Benzene, Hot	B	A	A	A	A
Benzoic Acid	B	A	A	A	A
Blood	D	A	A	A	A
Bromine, Dry Gas	D	A	A	B	A
Bromine, Moist Gas	D	D	D	D	C
Buttermilk	D	A	A	A	A
Calcium Bisulfite, Hot	D	C	B	A	A
Calcium Chloride, Dilute	C	B	A	A	A
Calcium Hydroxide, 20%, Boiling	D	A	A	A	A
Calcium Hydrochloride, < 2%	C	C	B	B	C
Carbolic Acid, 90%	C	A	A	A	B
Carbon Dioxide, Dry	C	A	A	A	A
Carbon Disulphide	B	A	A	A	B
Chloroacetic Acid	D	D	C	B	B
Chloric Acid	D	D	C	C	C
Chlorinated Water, Sat.	D	D	C	C	C
Chlorine, Dry Gas	B	B	B	A	A
Chlorine, Moist Gas	D	D	C	D	C
Citric Acid, Dilute	D	A	A	A	A
Citric Acid, Hot, Conc.	D	C	B	B	B
Creosote, Hot	B	A	A	A	A
Cupric Chloride, 5%	D	D	C	D	D
Ethyl Chloride	A	A	A	A	A
Ethylene Glycol	A	A	A	A	A
Ferric Chloride < 1%	D	C	B	B	C
Ferric Nitrate, 5%	D	B	A	C	D
Ferric Sulfate, 5%	D	B	A	B	C
Ferrous Sulfate, 10%	C	A	A	B	A
Flourine, Dry Gas	C	C	B	A	A
Flourine, Moist Gas	D	D	D	B	A
Freon, Wet	C	C	C	B	A
Fuel Oil, 140°F	A	A	A	A	B

CORROSION MEDIA					
	Carbon Steel	Stainless Steel 304	Stainless Steel 316	Inconel	Monel
Furfural	B	B	B	B	B
Gasoline Sour	B	A	A	C	C
Gasoline Refined	A	A	A	B	A
Gelatine	D	B	A	A	A
Glucose	B	A	A	A	A
Glycerine	B	A	A	A	A
Hydrofluoric Acid, Boiling	D	D	D	D	B
Hydrofluosilicic Acid	D	D	C	B	A
Hydrogen Chloride, Dry	B	D	C	A	A
Hydrogen Chloride, Moist	D	D	D	D	C
Hydrogen Fluoride, Dry	C	D	C	A	A
Hydrogen Peroxide, Boiling	D	C	B	B	B
Hydrogen Sulfide, Dry	B	A	A	A	A
Hydrogen Sulfide, Moist	C	B	A	A	B
Iodine, Dry	D	D	B	A	A
Kerosene	A	A	A	A	A
Lactic Acid, 5%	D	B	A	A	B
Lactic Acid, 10%	D	B	A	A	B
Lactic Acid, Boiling, 5%	D	C	B	B	C
Lactic Acid, Boiling, 10%	D	D	B	B	C
Lead Acetate, Hot	D	A	A	B	B
Magnesium Chloride, Hot, 5%	D	C	B	A	A
Magnesium Hydroxide	B	A	A	A	A
Magnesium Sulfate	B	A	A	B	A
Magnesium Sulfate, Boiling	C	A	A	C	A
Mercury	B	A	A	A	B
Mercuric Chloride, < 2%	D	D	D	D	D
Mercuric Cyanide	D	B	B	B	D
Methyl Chloride, Dry	D	B	B	A	A
Milk	D	A	A	A	B
Molasses	B	A	A	A	A
Naphtha	B	A	A	A	A
Nickel Chloride	D	C	B	B	B
Nickel Sulfate, Boiling	D	C	C	B	A
Nitric Acid, 20%	D	A	A	B	D
Nitric Acid, Boiling, Conc.	D	D	D	D	D
Nitrous Acid	D	B	B	B	C
Nitrobenzene	D	B	A	B	B
Oils - Miner.	B	A	A	C	B
Oxalic Acid, Boiling, 10%	C	A	A	A	A
Oxalic Acid, Boiling, 50%	D	D	C	B	B
Oxygen	B	A	A	A	A
Picric Acid	C	A	A	D	D
Potassium Bromide	D	C	B	A	A
Potassium Carbonate	B	A	A	A	A
Potassium Chlorate	B	A	A	A	B
Potassium Chloride	D	A	A	A	A
Potassium Chloride, Hot	D	C	B	B	A

CORROSION MEDIA					
	Carbon Steel	Stainless Steel 304	Stainless Steel 316	Inconel	Monel
Potassium Cyanide	B	B	B	B	B
Potassium Sulfate, Dil.	B	A	A	A	A
Propane, Liquid & Gas	B	A	A	A	A
Pyrogalllic Acid	B	A	A	B	A
Rosin, Molten	D	A	A	A	A
Salicylic Acid	D	B	B	B	B
Silver Bromide	D	B	A	C	B
Silver Chloride	D	D	D	C	B
Silver Nitrate	D	A	A	A	C
Sodium Acetate	C	A	A	A	A
Sodium Bisulfate	D	B	B	B	A
Sodium Bromide, Dil.	D	B	B	B	A
Sodium Cyanide	B	B	B	B	A
Sodium Fluoride, 5%	D	B	A	B	A
Sodium Hydroxide, 50%	B	A	A	A	A
Sodium Hyposulfite	D	B	A	B	A
Sodium Nitrate	B	B	A	A	B
Sodium Perborate	C	A	A	A	B
Sodium Peroxide	C	A	A	A	B
Sodium Phosphate, Tribasic	C	A	A	A	A
Sodium Silicate	B	A	A	A	B
Sodium Thiosulfate	D	B	A	B	B
Stannous Chloride, Sat.	D	D	B	B	B
Steam, 212°F	A	A	A	A	A
Steam, 600°F	C	A	A	A	A
Sulfite Liquors	D	C	B	D	D
Sulfur Chloride	D	C	D	B	B
Sulfur Dioxide, Moist	D	B	A	D	D
Sulfuric Acid, Conc.	B	B	B	B	D
Sulfurous Acid, Sat.	D	B	B	D	D
Tannic Acid, 10%	D	A	A	B	A
Tar, Hot	B	A	A	A	B
Tartaric Acid, 120°F	D	B	A	A	A
Toluene	A	A	A	A	A
Trichlorethylene	B	A	A	A	A
Turpentine	B	A	A	A	A
Varnish, Hot	C	A	A	A	A
Vegetable Oils	B	A	A	A	B
Vinegar	D	A	A	A	A
Water, Acid Mine	D	A	A	A	C
Water, Boiler Feed	B	A	A	A	A
Water, Distilled	D	A	A	A	A
Water, Salt Sea	D	C	B	B	A
Whiskey, Boiling	D	A	A	A	C
Wine	D	A	A	A	C
Xylene, Boiling	D	A	A	A	A
Zinc Chloride, 5%	D	C	B	B	B
Zinc Sulfate, Boiling	D	A	A	B	A



According to API 602 10th/ ISO 15761 - Class 800

SERVICE TEMP.	A105 ⁽¹⁾ A350-LF2 ⁽²⁾	A182 ⁽³⁾ F11	A182 ⁽³⁾ F22	A182 F5	A182 F9	A182 F304	A182 F316	A182 F304L	A182 F347H
F°	psi	psi	psi	psi	psi	psi	psi	psi	psi
-20 to 100	1975	2000	2000	2000	2000	1920	1920	1600	1920
200	1800	1900	1910	2000	2000	1600	1655	1350	1695
300	1750	1795	1805	1940	1940	1410	1495	1210	1570
400	1690	1755	1730	1880	1880	1255	1370	1100	1480
500	1595	1710	1705	1775	1775	1165	1275	1020	1380
600	1460	1615	1615	1615	1615	1105	1205	960	1310
650	1430	1570	1570	1570	1570	1090	1185	935	1280
700	1420	1515	1515	1515	1515	1075	1150	915	1250
750	1345	1420	1420	1420	1420	1060	1130	895	1230
800	1100	1355	1355	1325	1355	1050	1105	875	1215
850	715	1300	1300	1170	1300	1035	1080	860	1185
900	460	1200	1200	940	1200	1025	1050		1150
950	275	1005	1005	695	985	1000	1030		1030
1000	140	595	715	510	780	860	970		970
1050		365	530	375	505	825	960		960
1100		255	300	275	300	865	860		860
1150		140	275	185	200	520	735		735
1200		95	145	120	140	415	550		460
1250						295	485		330
1300						218	365		250
1350						165	275		180
1400						130	200		140
1450						95	155		110
1500						65	110		95

SERVICE TEMP.	A105 ⁽¹⁾ A350-LF2 ⁽²⁾	A182 ⁽³⁾ F11	A182 ⁽³⁾ F22	A182 F5	A182 F9	A182 F304	A182 F316
C°	bar	bar	bar	bar	bar	bar	bar
-29 to 38	136.2	137.9	137.9	137.9	137.9	132.4	132.4
93.5	124.1	131.0	131.7	137.9	137.9	110.3	114.1
149	120.7	123.8	124.5	133.8	133.8	97.2	103.1
204.5	116.6	121.0	119.3	129.7	129.7	96.5	94.5
260	110.0	117.9	117.6	122.4	122.4	80.3	87.9
315.5	100.7	113.4	113.4	113.4	113.4	76.2	83.1
343.5	98.6	108.3	108.3	108.3	108.3	75.2	81.7
371	97.9	104.5	104.5	104.5	104.5	74.1	79.3
399	92.7	97.9	97.9	97.9	97.9	73.1	77.9
426.5	75.9	93.4	93.4	91.4	93.4	72.4	76.2
454.5	49.3	89.7	89.7	80.7	89.7	71.4	74.5
482	31.7	82.8	82.8	64.8	82.8	70.7	72.4
510	19	69.3	69.3	47.9	67.9	69.0	71.0
538	9.7	41.0	49.3	35.2	53.8	59.3	66.9
565.5		25.2	36.6	25.9	34.8	56.9	66.2
593.5		17.6	20.7	19.0	20.7	47.2	59.3
621		9.7	19.0	12.8	13.8	35.9	50.7
649		6.6	10.0	8.3	9.6	28.6	37.9
676.5						20.3	33.4
704.5						15.0	25.2
732						11.4	19.0
5						9.0	13.8
760.5						6.6	10.7
788.5						4.5	7.6

NOTE: (1) Permissible, but not recommended for prolonged use above 800°F (427 °C); (2) Not to be used over 650 °F (343 °C); (3) Permissible, but not recommended for prolonged use above 1050°F (566 °C).

According to ASME B16.34 - Carbon Steel A105⁽¹⁾ & A350 LF2⁽²⁾

SERVICE TEMP.	150	300	600	1500	2500
F°	psi	psi	psi	psi	psi
-20 to 100	285	740	1480	3705	6170
200	260	675	1350	3375	5625
300	230	655	1315	3280	5470
400	200	635	1270	3170	5280
500	170	600	1200	2995	4990
600	140	550	1095	2735	4560
650	125	535	1075	2685	4475
700	110	535	1065	2665	4440
750	95	505	1010	2520	4200
800	80	410	825	2060	3430
850	65	270	535	1340	2230
900	50	170	345	860	1430
950	35	105	205	515	860
1000	20	50	105	260	430
1050					
1100					

SERVICE TEMP.	PN 20	PN 50	PN 100	PN 250
C°	bar	bar	bar	bar
38	19.6	51.5	102.1	255.3
50	19.2	50.1	100.2	250.4
100	17.7	46.4	92.8	231.9
150	15.8	45.2	90.5	226.1
200	14.0	43.8	87.6	219.1
250	12.1	41.7	83.4	208.6
300	10.2	38.7	77.5	193.7
350	8.4	37.0	73.9	184.8
375	7.4	36.5	72.9	182.3
400	6.5	34.5	69.0	172.5
425	5.6	28.8	57.5	143.8
450	4.7	20.0	40.1	100.2
475	3.7	13.5	27.1	67.7
500	2.8	8.8	17.6	44.0
525	1.9	5.2	10.4	25.9
540	1.3	3.3	6.5	16.3

NOTE: (1) Permissible, but not recommended for prolonged use above 800°F (2) Not to be used over 650 °F (343 °C)



BOLTED BONNET

OMB offers two different types of gaskets for the Bolted Bonnet connection valves: Spiral Wound and Ring Joint. Spiral Wound is a special integral ring retainer gasket that makes the most of the body/bonnet, being machined on the bonnet without requiring the addition of internal nor external rings.

Ring Joint is the standard feature for bolted bonnet valves Class 2500; upon request we can offer it for Classes 600 & 1500.

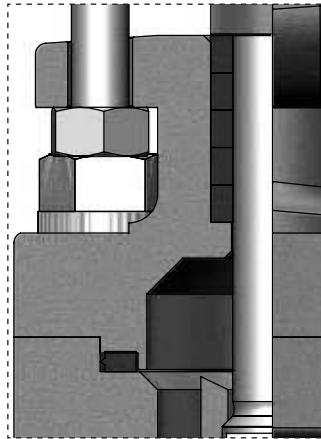

Gasket Joint

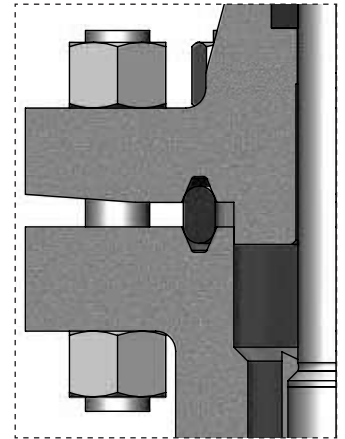

Ring Joint

WELDED BONNET

OMB can offer two types of welded body and bonnet connections: Screw and Seal Welded, and Full Penetration Weld (WP).

Full Penetration Weld (WP) will be provided as standard for Sour Services or when specified by the customer.

All OMB's welding procedures are in compliance with ASME IX standard; and consistently performed by qualified and certified operators.

Weld quality is verified by DPI test as standard. X-ray tests are available on request.

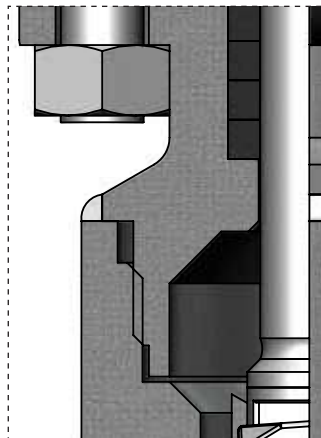

Screw and Seal Welded

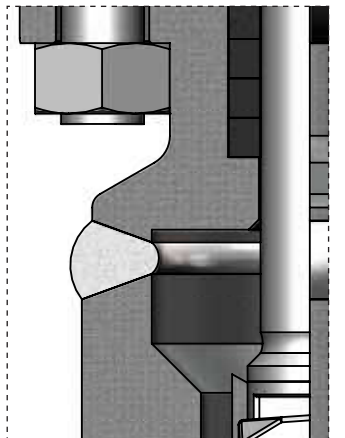

Full Penetration Weld "WP" (standard)

YOKE DESIGN

OMB can supply two different types of bonnet design based on the customer requirements. For valves' Class and Size information, please refer to the dimensional tables in this catalog.

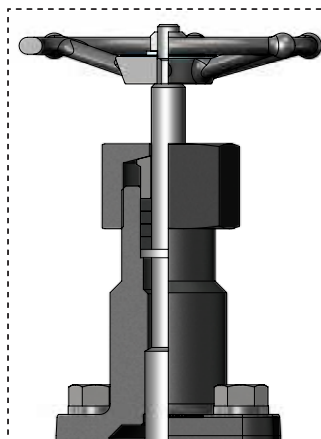

Inside Scw & Yoke

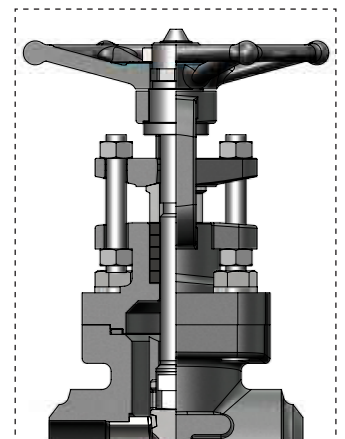

Outside Scw & Yoke

OBTURATOR DESIGN

GATE VALVES WEDGE SOLID WEDGE

OMB's Gate valves wedges are manufactured in forged to shape material to guarantee higher mechanical characteristics.
We offer our standard API602 valves with solid wedge guided by the body.

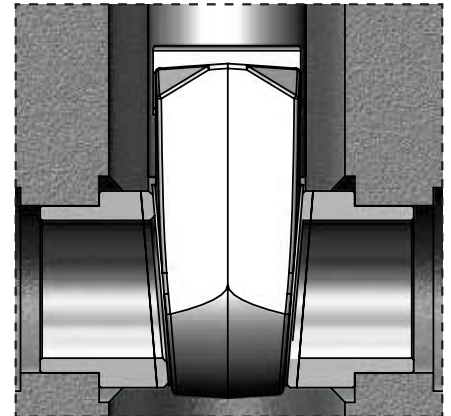

STANDARD

FLEXIBLE WEDGE

In application where thermal expansion is an issue, OMB offer a flexible wedge design. This design is ideal for are ideal for high pressure steam and other severe services and is suggested in size 1.1/2" and 2" only.
Always supplied on request.

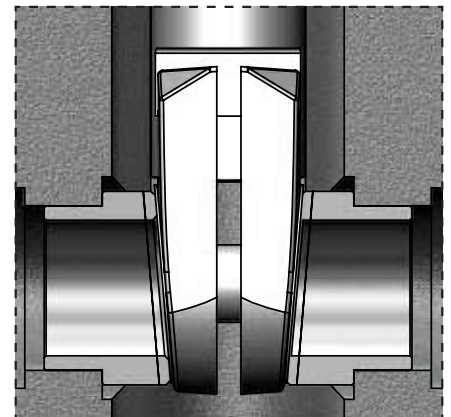

FLEXIBLE

WEDGE WITH BLEED HOLE

Is mounted on cryogenic and low temperature service valves in order to guarantee pressure balance between the inside of the body's cavity and the downstream pressure.
Upon request it can be mounted on non-cryogenic service valves.

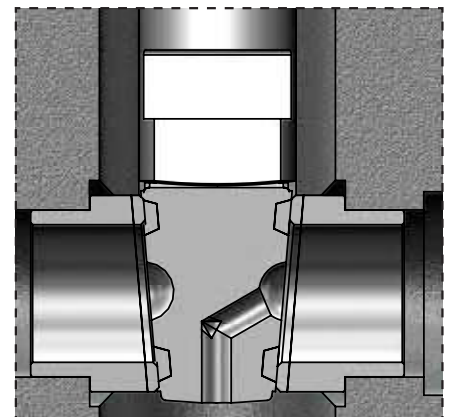

BLEED HOLE



Globe Valves Discs

OMB's Globe valves come with the Standard-type Disc (upper left). The Disc-with-insert type (upper right) is normally used on gas services and when minimizing leakages is critical. The Needle Disc (lower left) is used when a precise flow regulation is required. The Parabolic Disc (lower right) is a replacement of the Standard-type when looking for higher Cv's; its geometry helps decrease pressure drops, lowering fluid turbulences.

STANDARD

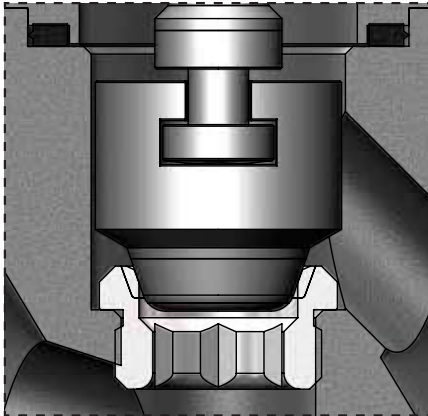

**DISC
W/INSERT**

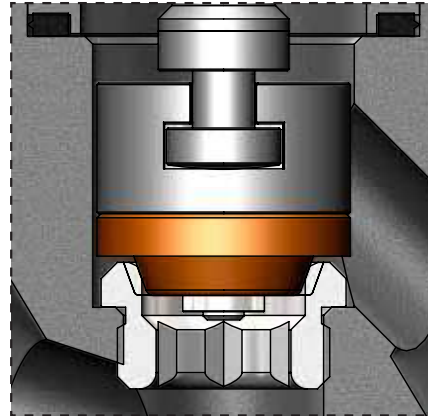

NEEDLE

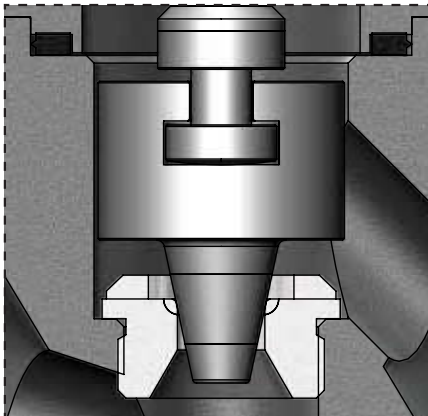

PARABOLIC

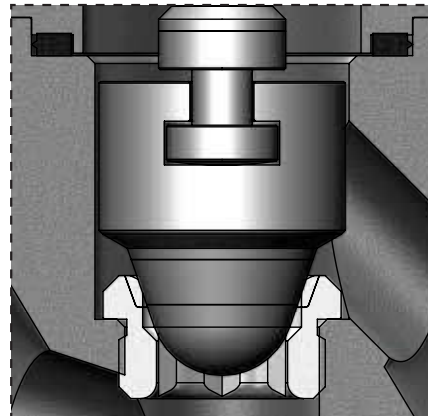

The V-Control type wedge (left) is the alternative when flow regulation is critical. Last, the Stop-Check (right) works as a regulation check valve, using the stem as the opening control device.

V CONTROL

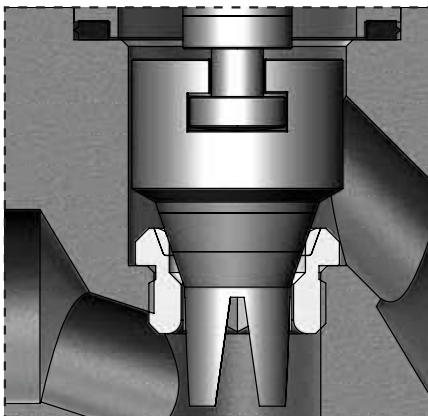

STOP CHECK

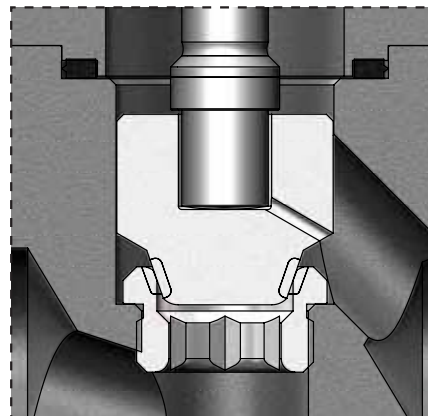

SEAT DESIGN

GATE AND SWING CHECK VALVES

OMB provides as standard Pressed-in-type seats.

Upon request we can provide a Welded-in version (left).

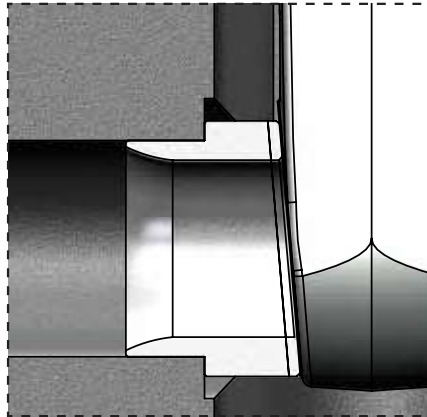

GATE PRESSED IN

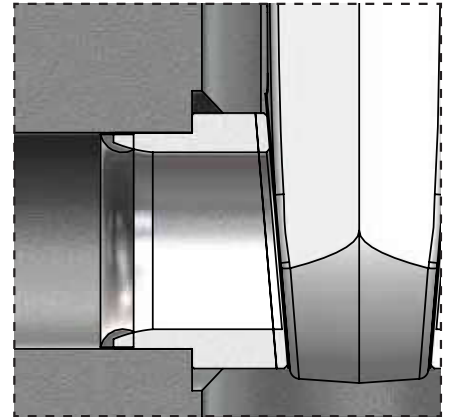

WELDED-IN

GLOBE AND PISTON/BALL CHECK VALVES

OMB offers replaceable Threaded type seat on bolted bonnet valves.

Integral type, machined on the body is offered on welded bonnet valves.

Upon request, all versions can be provided Hard Faced

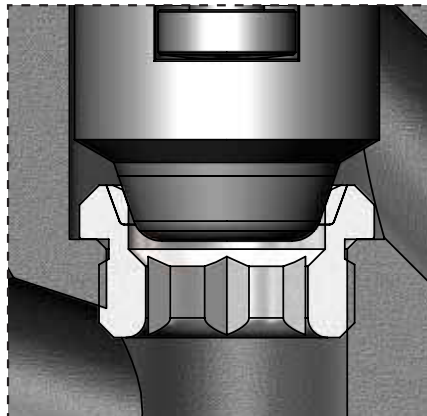

THREADED SEAT

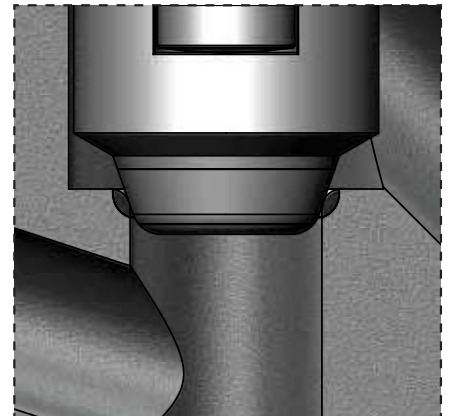

INTEGRAL BODY SEAT

STEM DESIGN

All OMB's Gate/Globe valves stem are Anti Blowout with integral Back Seat. Upon request, the stem/bonnet Back Seat area can be provided with hard facing (standard – hard facing on stem).

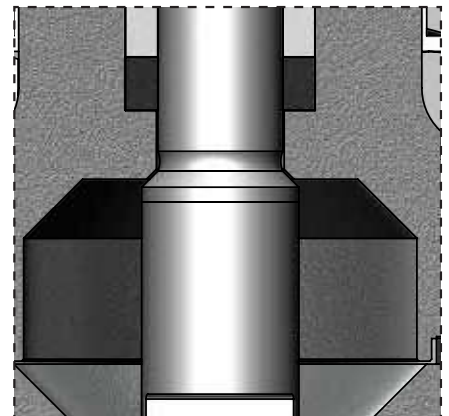

Asbestos-free packing is composed by a series of rings of pure graphite. The set is closed with two rings, top and bottom, anti-extrusion, manufactured in braided graphite. Both internal and external rings are treated with corrosion inhibitor.

Asbestos-free gaskets or Spiral Wound type gaskets are made of Stainless Steel 316 and pure graphite, and mounted on bolted bonnet valves up to Class 1500. Class 2500 valves are supplied with Ring Joint gaskets in accordance with ANSI B16.20 - API 6A. Class 1500 valves with Ring Joing gasket are available upon request.

Spare Parts OMB keeps in-house, an extensive inventory of packings and gaskets. In order to identify the required one, please refer to the information shown on OMB's data sheets (assembly drawings), indicating code and composition of the sets.

A complete and updated list of packings and gaskets for each design/figure is available online at www.ombvalves.com

FUGITIVE CONTROL OPTIONS

OMB offers a wide range of solutions to control fugitive emissions in packed valves.

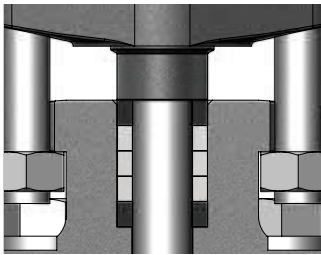

GRAPHITE PACKING

Graphite packing provides a tight control on the stem; material purity, density and chamber walls finishing guarantee an EPA leakproof sealing.

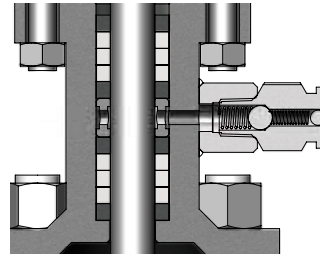

LANTERN PACKING

(on request)
The lantern ring solution provides a way to verify the packing operation and a grease injector (optional) to increase packing seal.

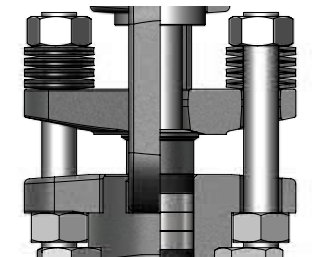

LIVE LOADING

Bolts Loaded Type
(on request)
Two sets of Belleville springs keep the gland flange pressure on the packing for long periods of time without maintenance.

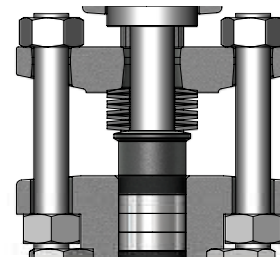

LIVE LOADING

Gland Loaded Type
(on request)
Sets of belleville springs keep gland pressure on packing for long periods of time without maintenance.

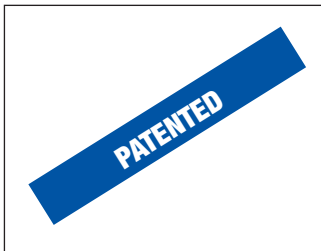

GARLOCK® EVSP 9000 FVP

(on request)
OMB offers this superior design Chevron-style graphite packing. ISA testing qualified for BP.

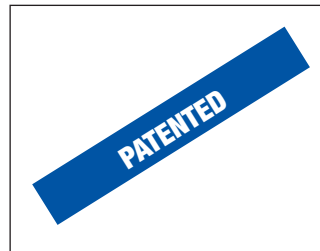

ARMA-SEAL 312 (TM)

(on request)
OMB qualified to ISO15848 testing using this special design packing. Shell 77/312 qualification.

EMISSION CONTROL TESTING & QUALIFICATION

OMB has been involved in extensive testings of various packing solutions which led to major improvements in the standard design and qualifications by the most critical specifications.

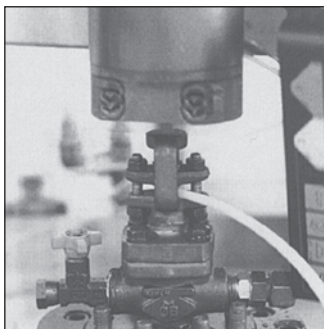

ISO testing - OMB LAB TESTING

Valve cycle tester using a mass spectrometer in sniffer mode to measure helium leakages from the valve gland.



API 624 TESTING

Valve Temperature and Pressure cycles with methane.



ISO 15848 TESTING

Emission test for combined Temperature and Pressure cycles. A mass spectrometer is used for leak rate measurements.



ISO 15848 PART I - FUGITIVE EMISSION TEST MATRIX

OMB completed the following test in order to qualify a complete product line for a major end user.

	DESIGN	TEMP. RANGE	TEST PROTOCOL NUMBER		
			150-600	1500	2500
Gate Valves ISO 15761/ API602, Wedge Type, Metal Seated, Rising Stem valves, Cryogenic.	Extended Bonnet	-196 to 300 °C	1	2	3
Gate Valves ISO 15761/ API602, Wedge Type, Metal Seated, Rising Stem valves.	Standard	-50 to 400 °C	4	5	6
Gate Valves ISO 15761/ API602, Wedge Type, Metal Seated, Rising Stem valves, High Temp.	Standard	0 to 650 °C	7	8	9
Globe Valves ISO 15761/ API602 (BS5352), Flanged, Plug/ball type, Cryogenic.	Straight Extended Bonnet	-196 to 300 °C	10	11	12
Globe Valves ISO 15761/ API602 (BS5352), Flanged, Plug/ball type.	Straight	-50 to 400 °C	13	14	15
Globe Valves ISO 15761/ API602 (BS5352), Flanged, Plug/ball type, High Temp.	Straight	0 to 650 °C	16	17	18
Globe Valves ISO 15761/ API602 (BS5352), Flanged, Plug/ball type.	Y-Pattern	-50 to 400 °C	19	20	21
Globe Valves ISO 15761/ API602 (BS5352), Flanged, Plug/ball type, High Temp.	Y-Pattern	0 to 650 °C	22	23	24
Check Valves ISO 15761/ API602 (BS5352), Piston Type, Bolted cover, cryogenic.	Straight	-196 to 300 °C	25	26	27
Check Valves ISO 15761/ API602 (BS5352), Piston Type, Bolted cover.	Straight	-50 to 400 °C	28	29	30
Check Valves ISO 15761/ API602 (BS5352), Piston Type, Welded cover, high temperature.	Straight	0 to 650 °C	31	30	33

API 624 - FUGITIVE EMISSION QUALIFICATION

All Gate valves class 150, 300, 600, 800 and 1500 are supplied with API622 qualified packing and certified to API624.

All Globe valves class 150, 300, 600, 800 and 1500 are supplied with API622 qualified packing and certified to API624



LOCKING DEVICE

Locking devices are mounted in order to prevent improper operations or accidentally unwanted maneuvers. OMB provides the Locking Device option 1 as standard (left) and the Locking Device option 2 upon request.

**LOCKING
DEVICE
OPTION 1**

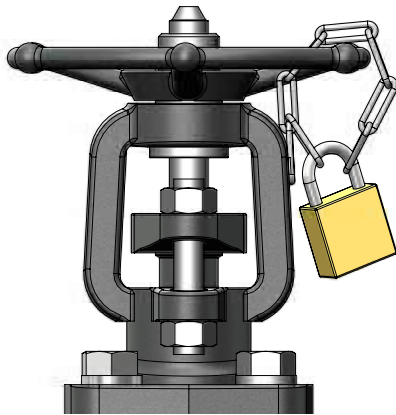

**LOCKING
DEVICE
OPTION 2**

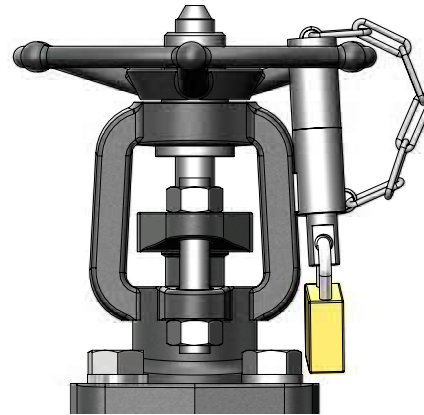

POSITION INDICATOR

A very useful solution for checking and/or correct positioning the wedge/disc inside the valve is the “position indicator”. Gate valves mount a graduated steel rod attached to the stem (following its vertical movement) and a cover (for protection puposes). On Globe valves graduated plate welded directly to the bonnet and a hood attached to the handwheel.

**POSITION
INDICATOR
(GATE)**

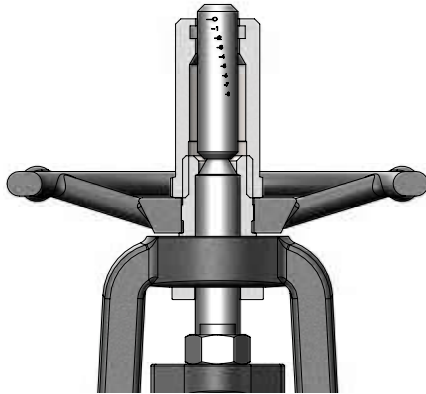

**POSITION
INDICATOR
(GLOBE)**

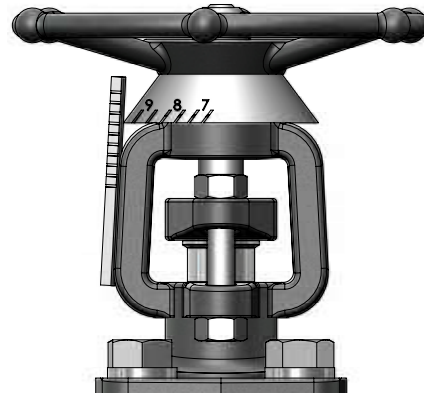

STEM PROTECTION

Upon request, OMB can provide further protection for the stem. Stem protection on Gate valves consists of a steel cover on the stem's upper section and a rubber bellows between the gland flange and the yoke nut. The stem protection on Globe valves is composed by two (2) bellows, one (1) between the gland flange and the yoke nut, and the other between the yoke nut and the handwheel.

**STEM
PROTECTION
(GATE)**

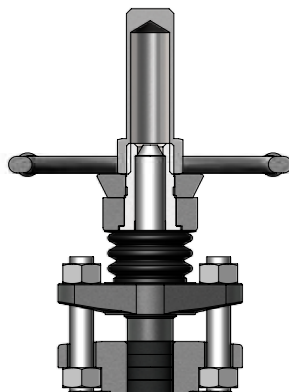

**STEM
PROTECTION
(GLOBE)**

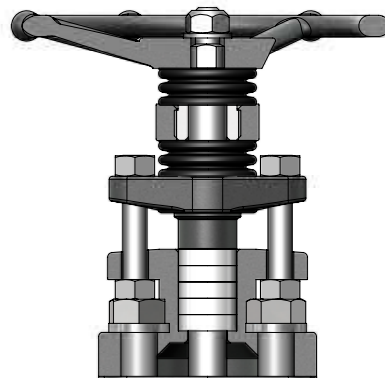

BODY/STEM GUIDED

OMB's valves are provided with a body guided or stem guided configuration. Please refer to the table below for Class/size standard design configurations. Standard body guided valves are also stem guided (BG+SG). When requested we can provide body guided design for all size valves can be supplied as body guided; design changes from one (1) piece disc to disc + locknut design.

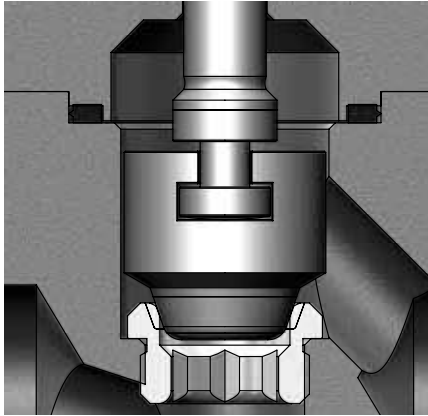

STD BODY GUIDED

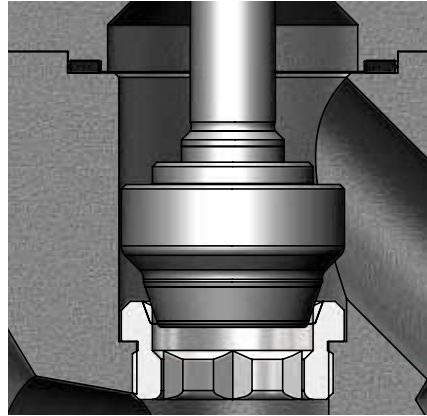

**DISC W/LOCKNUT
BODY GUIDED**

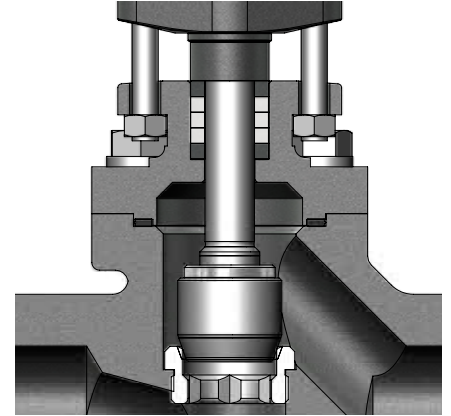

STEM GUIDED

OMB'S STANDARD FOR THE VALVE'S BODY/STEM GUIDED CONFIGURATION												
CLASS	150		300		600		800		1500		1500 FLANGED	
SIZE	FB	SB	FB	SB	FB	SB	FB	SB	FB	SB	FB	SB
1/4	-	-	-	-	-	-	BG+SG	-	BG+SG	-	-	-
1/8	-	-	-	-	-	-	BG+SG	-	BG+SG	-	-	-
1/2	BG+SG	BG+SG	BG+SG	BG+SG	BG+SG	BG+SG	BG+SG	BG+SG	BG+SG	BG+SG	BG+SG	-
3/4	BG+SG	BG+SG	BG+SG	BG+SG	BG+SG	BG+SG	BG+SG	BG+SG	BG+SG	BG+SG	BG+SG	-
1	BG+SG	BG+SG	BG+SG	BG+SG	BG+SG	BG+SG	BG+SG	BG+SG	BG+SG	BG+SG	BG+SG	-
1 1/4	-	-	-	-	-	-	SG	BG+SG	SG	BG+SG	-	-
1 1/2	SG	SG	SG	SG	SG	SG	SG	SG	SG	SG	SG	SG
2	SG	SG	SG	SG	SG	SG	SG	SG	SG	SG	SG	SG

DRAIN VALVE CONNECTION

OMB can supply a fitting (steel nipple welded to the bottom part of the body) and a NPT threaded plug. This connection is helpful for draining the valve on scheduled maintenance purposes.

**DRAIN VALVE
CONNECTION W/PLUG**

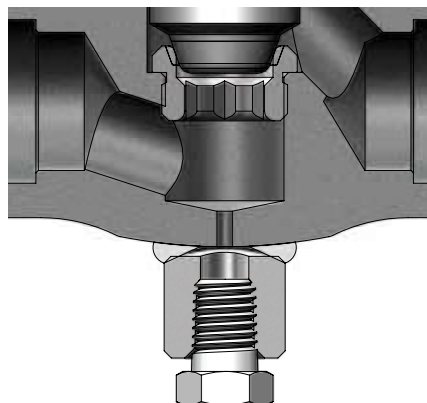

The “Cv” is a valve property and is defined as follows: “The Flow Coefficient (Cv) states the flow capacity of a valve in U.S. gallons per minute of water at a standard temperature of 60°F (15,6° C) that will flow through the valve with a pressure loss of one pound per square inch at a specific opening position”.

For the metric system the analog value is Kv where the units of measurement are bar (pressure), kilogram (mass) and meter (length). The Cv shows the quality and accuracy of a valve in terms of pressure loss; a highest value of Cv indicates a higher quality valve.

VALVE SIZE	CV TABLE							
	GATE		GLOBE			PISTON		
	Standard Bore	Full Bore	Standard Bore	Full Bore	Y-Pattern	Standard Bore	Full Bore	Y-Pattern
1/4	-	2.5	-	1.1	2.9	-	0.9	2.3
1/8	-	4.3	-	1.4	3.8	-	1.1	3.5
1/2	5.5	11.6	1.5	3.6	4.5	1	2.1	4.8
3/4	12	26.6	3.8	6.6	10.1	2.8	5.8	7.8
1	27	54.6	6.8	10.9	16	6	7	11.2
1 1/4	55	79.8	11	14	23.1	7.4	9.2	18.0
1 1/2	80	87	14.3	24.3	47.1	11	15.4	37.8
2	105	108	25	39.7	80.2	18	32	69.2

FLOW RATE

$$Q = C_v \times \sqrt{\frac{\Delta P}{SG}}$$

PRESSURE DROP

$$\Delta P = SG \times \left(\frac{Q}{C_v}\right)^2$$

CONVERSION TABLE TO METRIC Kv

Flow Coefficient	Cv	Kv
Cv	1	0.865
Kv	1.156	1

For liquids other than water
P = Pressure drop (psi).
Q = Liquid flow rate in gallons per minute (gpm).
SG = Specific gravity of liquid related to water (60°F).
Cv = Valves flow coefficient.



Since there is not a standard method to measure the exact Cv's value, OMB's R&D team uses two (2) different techniques: 1) By CFD (Computational Fluid Dynamics) analysis software which provides the flexibility to simulate specific services; 2) By specialized equipment monitoring a simulated pipeline.

CHECK VALVES CRACKING PRESSURE

VALVE FIGURE NUMBER	PISTON TYPE		Y-PATTERN PISTON TYPE		BALL TYPE		SWING	VERTICAL TYPE
	Non Spring Loaded	Spring Loaded	Non Spring Loaded	Spring Loaded	Non Spring Loaded	Spring Loaded	Non Spring Loaded	Spring Loaded
NPS	840	840 Spring	Y640	Y640 Spring	850	850 Spring	860	UV850
1/2" - 15	0.4 Bar	0.5 Bar	0.4 Bar	0.5 Bar	0.3 Bar	0.4 Bar	0.3 Bar	0.4 Bar
3/4 - 20	0.4 Bar	0.5 Bar	0.4 Bar	0.5 Bar	0.3 Bar	0.4 Bar	0.3 Bar	0.4 Bar
1" - 25	0.4 Bar	0.5 Bar	0.4 Bar	0.5 Bar	0.3 Bar	0.4 Bar	0.3 Bar	0.4 Bar
1 1/2" - 40	0.4 Bar	0.5 Bar	0.4 Bar	0.5 Bar	0.3 Bar	0.4 Bar	0.4 Bar	0.4 Bar
2 - 50	0.5 Bar	0.6 Bar	0.5 Bar	0.5 Bar	0.4 Bar	0.5 Bar	0.5 Bar	0.5 Bar
TYPE SCHEME								

Disclaimer. All above data have been calculated experimentally on production lost based on a standard combination of materials tested with air. Data may vary with fluid of higher or with spring/parts in special steel grades. In case of specific need we suggest you contact OMB center at the Bergamo plants.



Class 150-300-600-800

BS 5352 - API 602 10 TH / ISO 15761					
	DN	NPS	BS 5352 (OBSOLETE)		API 602 10 TH /ISO 15761
			STANDARD BORE	REDUCED BORE	MINIMUM DIAMETER
			GATE	8	
10	3/8	9		6	6
15	1/2	12		9	9
20	3/4	18		12	12
25	1	23		18	17
32	1 1/4	30		23	23
40	1 1/2	36		30	28
50	2	46,5		26	36
GLOBE	8	1/4	6	-	6
	10	3/8	9	6	6
	15	1/2	12	9	9
	20	3/4	17,5	12	12
	25	1	22,5	17,5	17
	32	1 1/4	29,5	22,5	23
	40	1 1/2	35	29,5	28
	50	2	45,5	35	36
CHECK	8	1/4	6	-	6
	10	3/8	9	6	6
	15	1/2	12	9	9
	20	3/4	17,5	12	12
	25	1	22,5	17,5	17
	32	1 1/4	29,5	22,5	23
	40	1 1/2	35	29,5	28
	50	2	45,5	35	36

OMB MINIMUM PASSAGEWAY				
	DN	NPS	STANDARD BORE	FULL BORE
			API 602 10 th	BS 5352
			SW, NPT, FLANGED END, BUTT WELD END	
GATE	8	1/4	6	6
	10	3/8	6	9
	15	1/2	9	12
	20	3/4	12	18
	25	1	17	23
	32	1 1/4	23	30
	40	1 1/2	28	36
	50	2	36	46,5
GLOBE	8	1/4	6	N/A
	10	3/8	6	N/A
	15	1/2	9	N/A
	20	3/4	12	N/A
	25	1	17	N/A
	32	1 1/4	23	N/A
	40	1 1/2	28	N/A
	50	2	36	N/A
CHECK	8	1/4	6	N/A
	10	3/8	6	N/A
	15	1/2	9	N/A
	20	3/4	12	N/A
	25	1	17	N/A
	32	1 1/4	23	N/A
	40	1 1/2	28	N/A
	50	2	36	N/A

Class 900-1500

BS 5352 - API 602 10 TH / ISO 15761					
	DN	NPS	BS 5352 (OBSOLETE)		API 602 10 TH /ISO 15761
			STANDARD BORE	REDUCED BORE	MINIMUM DIAMETER
			GATE	8	
10	3/8	-		N/A	6
15	1/2	11,5		N/A	9
20	3/4	15		N/A	12
25	1	19,5		N/A	15
32	1 1/4	28		N/A	22
40	1 1/2	32		N/A	27
50	2	40		N/A	34
GLOBE	8	1/4	-	N/A	5
	10	3/8	-	N/A	5
	15	1/2	11	N/A	8
	20	3/4	14,5	N/A	9
	25	1	19	N/A	14
	32	1 1/4	27	N/A	20
	40	1 1/2	31	N/A	25
	50	2	37,5	N/A	27
CHECK	8	1/4	-	N/A	5
	10	3/8	-	N/A	5
	15	1/2	11	N/A	8
	20	3/4	14,5	N/A	9
	25	1	19	N/A	14
	32	1 1/4	27	N/A	20
	40	1 1/2	31	N/A	25
	50	2	37,5	N/A	27

OMB MINIMUM PASSAGEWAY				
	DN	NPS	STANDARD BORE	FULL BORE
			API 602 10 th	BS 5352
			SW, NPT, FLANGED END (End to End OMB dimension)	FLANGED END, BUTTWELDED END (End to End OMB dimension as per ASME B16.10)
GATE	8	1/4	6	-
	10	3/8	6	-
	15	1/2	9	11,5
	20	3/4	12	15
	25	1	15	19,5
	32	1 1/4	22	28
	40	1 1/2	27	32
	50	2	34	40
GLOBE	8	1/4	5	-
	10	3/8	5	-
	15	1/2	8	11
	20	3/4	9	14,5
	25	1	14	19
	32	1 1/4	20	27
	40	1 1/2	25	31
	50	2	27	37,5
CHECK	8	1/4	5	-
	10	3/8	5	-
	15	1/2	8	11
	20	3/4	9	14,5
	25	1	14	19
	32	1 1/4	20	27
	40	1 1/2	25	31
	50	2	27	37,5



FLANGE FACES

Different types of flange faces are used as the contact surface to position the sealing gasket. ASME B16.5 and B16.47 define various types of flange facings.

RAISED FACE

The **Raised Face (RF)** flange is the most common type used in process plant applications, and it is easy to identify. It is referred to as a raised face because the gasket surfaces are raised above the bolting circle face. This face type allows the use of a wide combination of gasket designs. The purpose of a RF flange is to concentrate more pressure on the smaller gasket area and increase the pressure containment capability of the joint. Diameters and heights are defined in ASME B16.5 by pressure Class. Pressure rating of the flange determines the height of the RF. The typical flange face surface finish range for ASME B16.5 RF flanges is 125 to 250 $\mu\text{in Ra}$ (3 to 6 $\mu\text{m Ra}$)

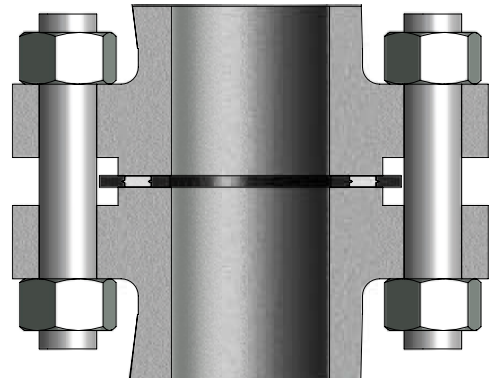

COD.	DESCRIPTION		STANDARD
RF	Smooth Finish 3.2 - 6.3	Spiral	ASME B16.5
RS	Stock Finish 6.3 - 12.5	Spiral	ASME B16.5
RN	Stock Finish Spec. 1.6 - 3.2	Spiral	ASME B16.5
RC	Smooth Finish 3.2 - 6.3	Concentric	ASME B16.5
RT	Stock Finish 6.3 - 12.5	Concentric	ASME B16.5

FLAT FACE

The **Flat Face (FF)** flange has a gasket surface on the same plane as the bolting circle face. Applications using FF flanges are frequently those in which the matig fange or flanged fitting is made from a casting. Flat Face flanges are not designed to be bolted to a RF flange.

COD.	DESCRIPTION	STANDARD
FF	Smooth Finish 3.2 - 6.3	ASME B16.5
FS	Stock Finish 6.3 - 12.5	ASME B16.5

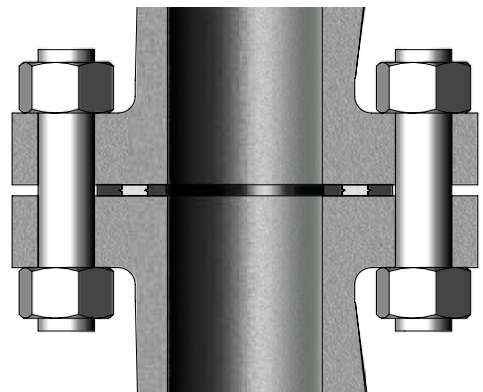

RING-TYPE JOINT (RTJ)

The **Ring-Type Joint (RTJ)** flanges are typically used in High Pressure (Class 600 and higher ratings) and/or High Temperature services above 800°F (472°C). They have V-Cut grooves machined on their faces in which steel ring gaskets are placed. The flanges seal when tightened bolts compress the gasket between the flanges into the grooves, deforming (or Coining) the gasket to make intimate contact inside the grooves, creating a metal to metal seal. An RTJ flanges may have a raised face with a ring groove machined into it.

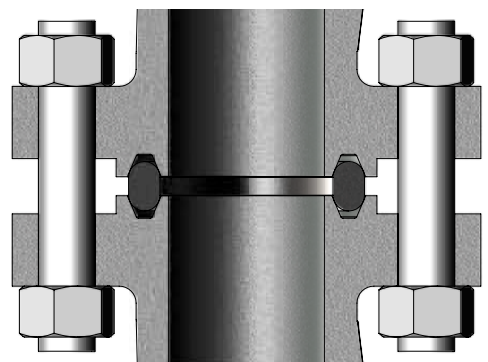

TONGUE-AND-GROOVE (T&G)

The **Tongue-and-Groove** (T&G) faces must match; one of them has a raised ring (Tongue) machined on its surface while the mating flange has an indentation (Groove) machined into its face's surface. Tongue and Groove facings are standardized in both, large and small types. The difference between T&G and M&F is that the T&G do not extend its inside diameters to the flange bore, thus retaining the gasket on its inner and outer diameter. These are commonly found on pump covers and Valve Bonnet.

COD.	DESCRIPTION	STANDARD
SG	Small Groove	ASME B16.5
LG	Large Groove	ASME B16.5
SM	Small Tongue	ASME B16.5
LM	Large Tongue	ASME B16.5

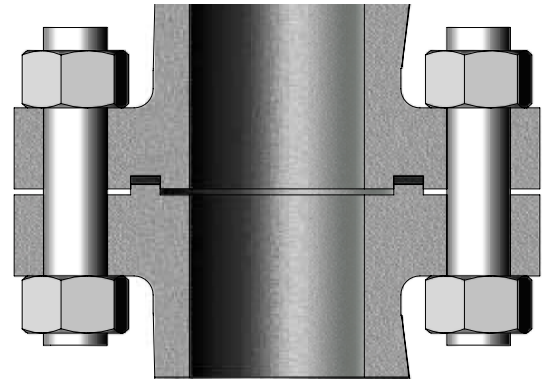

MALE-AND-FEMALE (M&F)

This type of flanges must be matched. The female face is 3/16 inch deep, the male face is 1/4 inch high, and both are usually smooth finished. The outer diameter of the female face acts to locate and retain the gasket. One flange face has a rim (lip) extended beyond the normal flange face (Male). The other flange has a matching depression (Female) machined on the entire circumference of its face.

COD.	DESCRIPTION	STANDARD
LF	Large Female	ASME B16.5
LM	Large Male	ASME B16.5

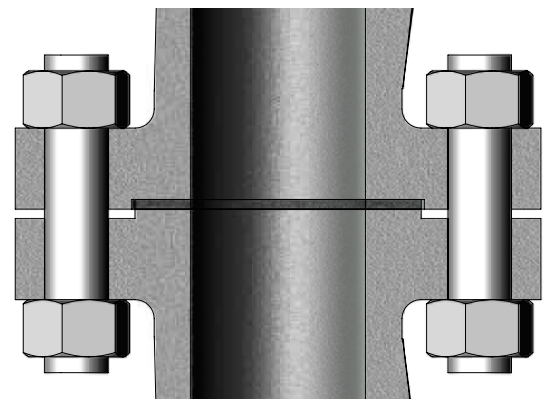

FLANGE DIMENSIONS

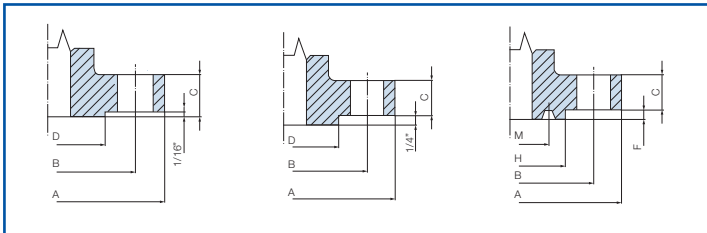

One (1) feature that makes flanged version valves so valuable is that they can be easier to replace on the pipeline in comparison to the other ends connections by just removing the threaded rods; it is useful when a malfunction occurs or just when maintenance is required. It is worth mentioning that their end-to-end dimensions are in accordance with international standards.

CLASS	SIZE	A		C		D		B		BOLT HOLED			RING JOINT FACING					RING N.		
										N	SIZE		H		M		F			
150	1/2	3.50	89.0	0.44	11.5	1.38	34.9	2.38	60.5	4	0.62	16.0	-	-	-	-	-	-	-	-
	3/4	3.88	98.5	0.50	13.0	1.69	42.9	2.75	70.0	4	0.62	16.0	-	-	-	-	-	-	-	-
	1	4.25	108.0	0.56	14.5	2.00	50.8	3.12	79.5	4	0.62	16.0	2.50	63.5	1.875	47.62	0.250	6.4	R 15	
	1 1/4	4.62	117.5	0.62	16.0	2.50	63.5	3.50	89.0	4	0.62	16.0	2.88	73.0	2.250	57.15	0.250	6.4	R 17	
	1 1/2	5.00	127.0	0.69	18.0	2.88	73.0	3.88	98.5	4	0.62	16.0	3.25	82.5	2.562	65.07	0.250	6.4	R 19	
	2	6.00	152.5	0.75	19.5	3.62	92.1	4.75	120.5	4	0.75	19.0	4.00	101.5	3.250	82.55	0.250	6.4	R 22	
300	1/2	3.75	95.5	0.56	14.5	1.38	34.9	2.62	66.5	4	0.62	16.0	2.00	50.8	1.344	34.14	0.219	5.6	R 11	
	3/4	4.62	117.5	0.62	16.0	1.69	42.9	3.25	82.5	4	0.75	19.0	2.50	63.5	1.688	42.88	0.250	6.4	R 13	
	1	4.88	124.0	0.69	18.0	2.00	50.8	3.50	89.0	4	0.75	19.0	2.75	69.9	2.000	50.80	0.250	6.4	R 16	
	1 1/4	5.25	133.5	0.75	19.5	2.50	63.5	3.88	98.5	4	0.75	19.0	3.12	79.2	2.375	60.32	0.250	6.4	R 18	
	1 1/2	6.12	156	0.81	21.0	2.88	73.0	4.50	114.5	4	0.88	22.0	3.56	90.44	2.688	68.28	0.250	6.4	R 20	
	2	6.50	165.5	0.88	22.5	3.62	92.1	5.00	127.0	8	0.75	19.0	4.25	108.0	3.250	52.55	0.312	7.9	R 23	
600	1/2	3.75	95.5	0.56	14.5	1.38	34.9	2.62	66.5	4	0.62	16.0	2.00	50.5	1.344	34.14	0.219	5.6	R 11	
	3/4	4.62	117.5	0.62	16.0	1.69	42.9	3.25	82.5	4	0.75	9.0	2.50	63.5	1.688	42.88	0.250	6.4	R 13	
	1	4.88	124.0	0.69	18.0	2.00	50.8	3.50	89.0	4	0.75	19.0	2.75	69.9	2.000	50.80	0.250	6.4	R 16	
	1 1/4	5.25	133.5	0.81	21.0	2.50	63.5	3.88	98.5	4	0.75	19.0	3.12	79.4	2.375	60.32	0.250	6.4	R 18	
	1 1/2	6.12	156.0	0.88	22.5	2.88	73.0	4.50	114.5	4	0.88	22.0	3.56	90.5	2.688	68.25	0.250	6.4	R 20	
	2	6.50	165.5	1.00	25.5	3.62	92.1	5.00	127.0	8	0.75	19.0	4.25	108.0	3.250	82.55	0.312	7.9	R 23	
1500	1/2	4.75	121.0	0.88	22.5	1.38	34.9	3.25	82.5	4	0.88	22.0	2.38	60.3	1.562	39.67	0.250	6.4	R 12	
	3/4	5.12	130.5	1.00	25.5	1.69	42.9	3.50	89.0	4	0.88	22.0	2.62	66.7	1.750	44.45	0.250	6.4	R 14	
	1	5.88	149.5	1.12	29.0	2.00	50.8	4.00	101.5	4	1.00	25.5	2.81	71.4	2.000	50.80	0.250	6.4	R 16	
	1 1/4	6.25	159.0	1.12	29.0	2.50	63.5	4.38	111.0	4	1.00	25.5	3.19	81.0	2.375	60.32	0.250	6.4	R 18	
	1 1/2	7.00	178.0	1.25	32.0	2.88	73.0	4.88	124.0	4	1.12	28.5	3.62	92.1	2.688	68.28	0.250	6.4	R 20	
	2	8.50	216.0	1.50	38.5	3.62	92.1	6.50	165.0	8	1.00	25.5	4.88	123.8	3.750	95.25	0.312	7.9	R 24	
2500	1/2	5.23	133.5	1.20	30.5	1.38	34.9	3.50	89.0	4	0.88	22.0	2.55	65.1	1.688	42.88	0.250	6.4	R 13	
	3/4	5.51	140.0	1.25	32.0	1.69	42.9	3.74	95.0	4	0.88	22.0	2.87	73.0	2.000	50.80	0.250	6.4	R 16	
	1	6.25	159.0	1.37	35.0	2.00	50.8	4.24	108.0	4	1.00	25.5	3.24	82.5	2.375	60.32	0.250	6.4	R 18	
	1 1/4	7.24	184.5	1.51	38.5	2.50	63.5	5.12	130.0	4	1.12	28.5	3.99	101.5	2.844	72.24	0.312	7.9	R 21	
	1 1/2	7.99	203.5	1.75	44.5	2.88	73.0	5.74	146.0	4	1.25	31.5	4.50	114.3	3.250	82.55	0.312	7.9	R 23	
	2	9.25	235.0	2.00	51.0	3.62	92.1	6.74	171.5	8	1.12	28.5	5.25	133.3	4.000	101.60	0.312	7.9	R 26	

Flange dimensions in accordance with ASME B16.5

SOCKET WELD

A **Socket Welded** is a pipe attachment detail in which a pipe is inserted into a recessed area of a valve, fitting or flange. In contrast to butt weld fittings, Socket Welded fittings are mainly used for small pipe diameters. Fatigue resistance is lower than that in butt-welded construction but it is still better than that of most mechanical joining methods.

SIZE	ØD		L (MIN)		L (OMB)	
	MM	INCH	MM	INCH	MM	INCH
1/4"	14.20	0.557	9.53	0.38	11.1	0.44
3/8"	17.60	0.690	9.53	0.38	11.1	0.44
1/2"	21.80	0.855	9.53	0.38	12.7	0.5
3/4"	27.20	1.065	12.70	0.5	14.5	0.57
1"	33.90	1.330	12.70	0.5	16.0	0.63
1 1/4"	42.70	1.675	12.70	0.5	17.5	0.69
1 1/2"	48.80	1.915	12.70	0.5	19.0	0.75
2"	61.20	2.406	15.88	0.62	22.0	0.86

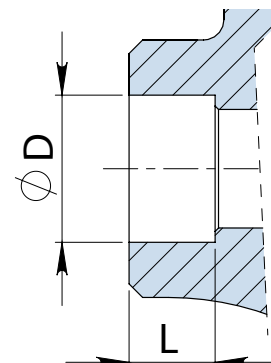

Socket weld dimensions in accordance with API 602/ISO 15761/ASME B16.11 74 Socket wall thickness according to ASME B16.34



THREADED END (NPT)

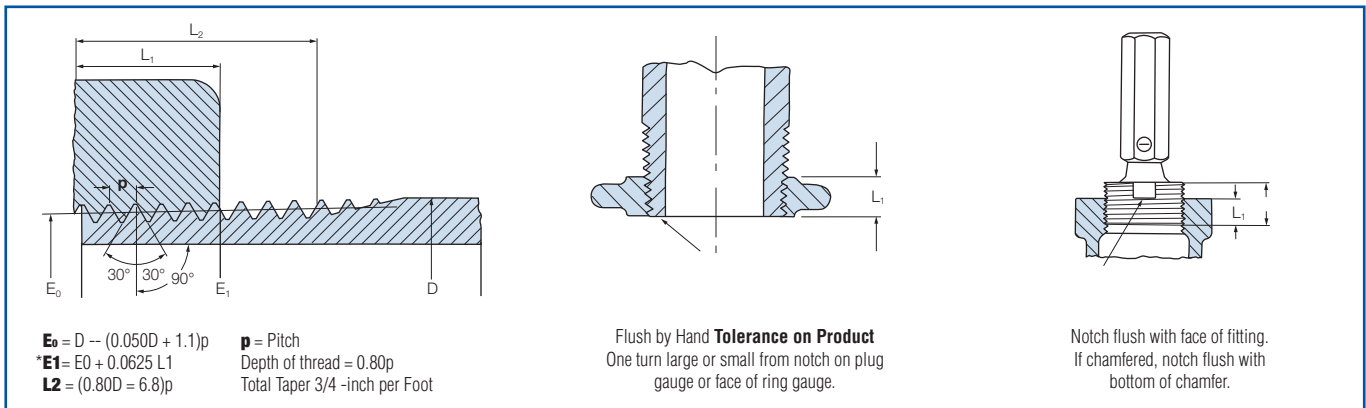

Threaded joints probably represent the oldest method of joining piping systems. Like Socket Weld fittings, threaded fittings are mainly used for small pipe diameters. The dimensional

standards for taper pipe threads are given in ASME B1.20.1. NTP have a tapered male and female thread which seal with Teflon[®] tape or jointing compound.

NOMINAL PIPE SIZE	D Outside diameter of pipe	Number of threads per inch	p Pitch of thread	E_0 Pitch diameter at end of external thread	E_1 ■ Pitch diameter at end of external	E_1 ● Normal engagement by and between external and internal threads	E_1 ◆ Length of effective external thread	Height of thread
1/16	0.3125	27	0.03704	0.27118	0.8118	0.160	0.2611	0.02963
1/8	0.405	27	0.3704	0.36351	0.37360	0.1615	0.2639	0.02963
1/4	0.540	18	0.05556	0.47739	0.49163	0.2278	0.4018	0.04444
3/8	0.675	18	0.05556	0.61201	0.62701	0.240	0.4078	0.04444
1/2	0.840	14	0.07143	0.75843	0.77843	0.320	0.5337	0.05714
3/4	1.050	14	0.07143	0.96768	0.98887	0.339	0.5457	0.05714
1	1.315	11.5	0.08696	1.23863	1.23863	0.400	0.6828	0.06957
1 1/4"	1.660	11.5	0.08696	1.55713	1.58338	0.420	0.7068	0.06957
1 1/2"	1.900	11.5	0.08696	1.79609	.82234	0.420	0.7235	0.06957
2	2.375	11.5	0.08696	2.2692	2.29627	0.436	0.7565	0.06957

Threaded ends dimensions in accordance with B1.20.1/B16.11

- Also pitch diameter at gauging notch.
- ◆ Also length of plug gauge.
- Also length of ring gauge, and length from gauging notch to small end of plug gauge.
- * For the 1/8-27 and 1/4-18 sizes... E_1 approx. = $D - (0.05D + 0.827)p$.



BUTT WELD (SH)

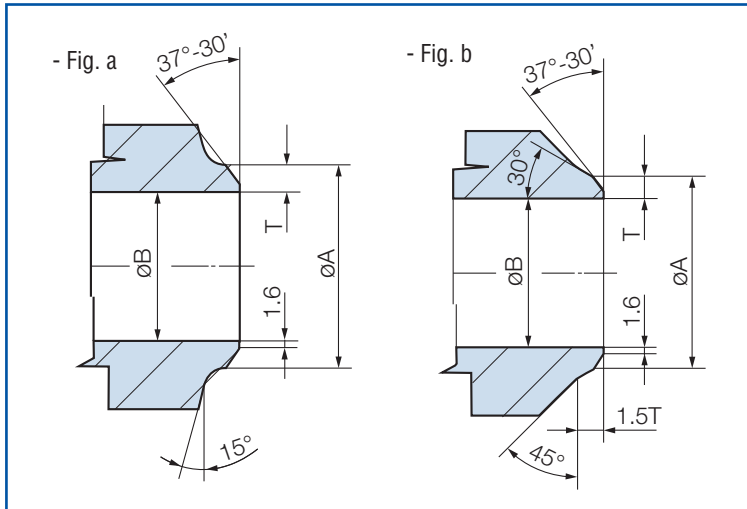

A pipe fitting is defined as part used in a piping system for changing direction, branching or for changing pipe's diameter and which is mechanically joined to the system. The most common materials used in fittings are carbon steel, stainless steel, cast iron, aluminium, copper, glass, rubber, various type of plastics, etc.. The material of a fitting is basically set during the choice of the pipe. The ends of all butt weld fittings are beveled, exceeding wall thickness 4 mm for austenitic stainless steel or 5 mm for ferritic stainless steel. This beveled-ends are needed to be able to make a "Butt Weld".

ASME B16.25 covers the preparation of butt welding ends of piping components to be joined into a piping system by welding.

COD.	DESCRIPTION	STANDARD
S1	SH10	ASME B16.25
S4	SH40	ASME B16.25
S8	SH80	ASME B16.25
S6	SH160	ASME B16.25
SX	SHXXS	ASME B16.25

SIZE	SCHEDULE 40		SCHEDULE 80		SCHEDULE 160		SCHEDULE XXS	
	ØA	T	ØA	T	ØA	T	ØA	T
	mm (in)	mm (in)	mm (in)	mm (in)	mm (in)	mm (in)	mm (in)	mm (in)
1/2"	21.3	2.77	21.3	3.73	21.3	4.78	21.3	7.47
	(0.840)	(0.190)	(0.840)	(0.147)	(0.840)	(0.188)	(0.840)	(0.294)
3/4"	26.7	2.87	26.7	3.91	26.7	5.56	26.7	7.82
	(1.050)	(0.113)	(1.050)	(0.154)	(1.050)	(0.219)	(1.050)	(0.308)
1"	33.4	3.38	33.4	4.55	33.4	6.35	33.4	9.09
	(1.315)	(0.133)	(1.315)	(0.179)	(1.315)	(0.250)	(1.315)	(0.358)
1 1/4"	42.2	3.55	42.2	4.85	42.2	6.35	42.2	9.70
	(1.660)	(0.140)	(1.660)	(0.19)	(1.660)	(0.250)	(1.660)	(0.382)
1 1/2"	48.3	3.68	48.3	5.08	48.3	7.14	48.3	10.15
	(1.900)	(0.145)	(1.900)	(0.200)	(1.900)	(0.281)	(1.900)	(0.400)
2"	60.3	3.91	60.3	5.54	60.3	8.74	60.3	11.07
	(2.375)	(0.154)	(2.375)	(0.217)	(2.375)	(0.344)	(2.375)	(0.436)
2 1/2"	73.0	5.15	73.0	7.01	73.0	9.53	73.0	14.02
	(2.875)	(0.203)	(2.875)	(0.276)	(2.875)	(0.375)	(2.875)	(0.552)
3"	88.9	5.48	88.9	7.62	88.9	11.13	88.9	15.24
	(3.500)	(0.216)	(3.500)	(0.300)	(3.500)	(0.438)	(3.500)	(0.600)
4"	114.3	6.02	114.3	8.56	114.3	13.49	114.3	17.12
	(4.500)	(0.237)	(4.500)	(0.337)	(4.500)	(0.531)	(4.500)	(0.674)

Butt weld dimensions in accordance with ASME B16.25

Fig. a ≤ 2" | Fig. b > 2" | A = B - 2T



NIPPLES

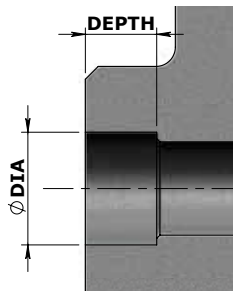

A pipe fitting consisting of a short piece of pipe, used for connecting two (2) other fittings or transforming/reducing from a larger to a smaller pipe size on each end. The end must have pipe threads or butt weld preparations concentric from a common axis.

Type "L"

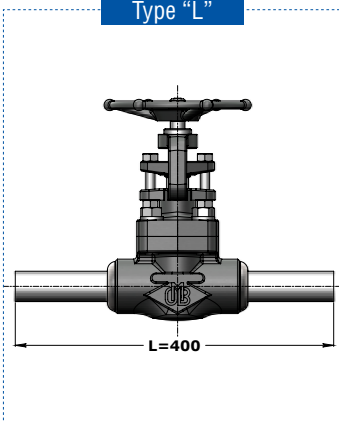

Long Pattern Total length 400 mm.

Type "S"

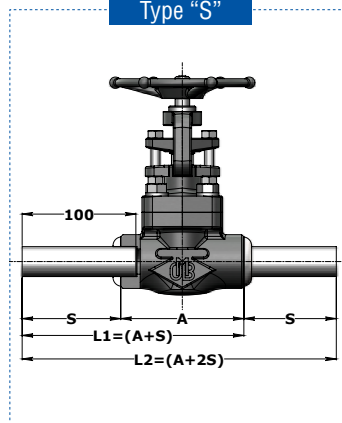

A = See relevant Product/Size/Class table within this catalog
S = See table Socket Weld

VALVES WITH NIPPLES LENGTHS

NPT	DN	SOCKET BORE DIA.		SOCKET DEPTH		S	
		mm	in	mm	in	mm	in
1/4	8	14.2	0.557	11.1	0.437	89	3.503
3/8	10	17.6	0.690	11.1	0.437	89	3.503
1/2	15	21.8	0.855	12.7	0.500	88	3.464
3/4	20	27.2	1.065	14.5	0.570	86	3.385
1	25	33.9	1.330	16	0.629	85	3.346
1 1/4	32	42.57	1.675	17.5	0.688	83	3.267
1 1/2	40	48.8	1.915	19	0.748	82	3.228
2	50	61.2	2.406	22	0.866	79	3.110

Nipples dimensions in accordance with ASME B36.10

CLAMP (CL)



Clamps are a line joint usually installed on high pressure pipelines with a metal-to-metal sealing system. Clamp ends dimensions are in accordance with each clamp manufacturer's standards and can be applied to any type of valve.

BODY-TO-BONNET BOLTING MATERIALS

STUD BOLTS		NUTS	
ASTM Bolting Material	EN 10269 Bolting Material Grade	ASTM Bolting Material	EN 10269 Bolting Material Grade
A193 B7 A 193 B16	42CrMo4 (1.7225) QT 40CrMoV4-6 (1.7711) - QT	A 193 B8M2, CL 2B A 193 B8M3, CL 2C	X5CrNiMo 17-12-2 (1.4401) - C700 X5CrNiMo 17-12-2 (1.4401) - C700
A 193 B8M, CL 2 A 194 2H	X5CrNiMo 17-12-2 (1.4401) C45E (1.1191) - QT	A 193 B8M, CL 1 A 193 B8MA, CL 1A	X5CrNiMo 17-12-2 (1.4401) - AT X5CrNiMo 17-12-2 (1.4401) - AT
A194 8M	X5CrNiMo 17-12-2 (1.4401) - AT	A 193 B8, CL 1 A193 B8A, CL 1A	X5CrNiMo 18-10 (1.4301) - AT X5CrNiMo 18-10 (1.4301) - AT
-	-	A 193, B8 CL 2 A 320, L7	X5CrNi 18-10 (1.4301) - C700 42CrMo4 (1.7225) - QT
-	-	A 194 GR 8 A194 GR 4	X5CrNi 18-10 (1.4301) - AT 42CrMo4 (1.7225) - QT
-	-	A 194 GR 7	42CrMo4 (1.7225) - QT

THERMAL EXPANSION OF BOLTS ON FORGED STEEL VALVES

Thermal Expansion of bolting in B7 and B8 material used in Forged Steel valves made according to ISO 15761/API 602. The following table gives the mechanical properties of the most common bolt materials used in the Forged Steel valves.

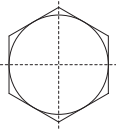
Identification Grade Mark 	Specification	Material	Nominal Size Range (in.)	Linear Thermal Expansion Coefficient (°C-1)	Mechanical Properties		
					Proof Load (psi)	Yield Strength Min (psi)	Tensile Strength Min (psi)
B7	ASTM A193 type - Grade B7	4140, 4142, OR 4105	1/4 thru 2-1/2 Over 2-1/2 thru 4 Over 4 thru	12 * 10 ⁻⁶	-- -- --	105,000 95,000 75,000	125,000 115,000 100,000
B16	ASTM A193 type - Grade B16	CrMoVa Alloy Steel	1/4 and larger	11 * 10 ⁻⁶	--	105,000 95,000 85,000	125,000 115,000 100,000
B8	ASTM A193 Grade B8	AISI 304	1/4 thru 3/4 Over 3/4 to 1-1/2	11 * 10 ⁻⁶	55,000 33,000	30,000	75,000
B8M	ASTM A193 Grade B8M	AISI 316	1/4 thru 2-1/2 Over 2-1/2 thru 4 Over 4 thru 7	11 * 10 ⁻⁶	-- -- --	105,000 95,000 75,000	125,000 115,000 100,000



STANDARD VALVES SPARE PARTS



OMB recommends packing and gaskets as the primary valves' spare parts.

We provide below a list of the bonnet cap screw specifications, which can be used to track spare parts for the most common valves. All other valves' spares can be requested directly to OMB or any of the OMB's approved distributors.

VALVE TYPE	CLASS	BASE FIGURE NO	NPS	PACKING CODE	GASKET CODE	BONNET CAPSCREW	GLAND STUD
STDB Gate	150-800#	810	0.50"	T2	40x30	M10x25	M8x42
STDB Gate	150-800#	810	0.75"	T2	40x30	M10x25	M8x42
STDB Gate	150-800#	810	1"	T4	48x38	M12x30	M8x48
STDB Gate	150-800#	810	1.25"	T5	54x44	M12x35	M10x58
STDB Gate	150-800#	810	1.50"	T6	66x54	M14x35	M10x60
STDB Gate	150-800#	810	2"	T6	74x50	M16x40	M10x60

Note: STDB = Standard Bore

VALVE TYPE	CLASS	BASE FIGURE NO	NPS	PACKING CODE	GASKET CODE	BONNET CAPSCREW	GLAND STUD
STDB Gate	150-800#	830	0.50"	T2	40x30	M10x25	M8x42
STDB Gate	150-800#	830	0.75"	T3	40x30	M10x25	M8x42
STDB Gate	150-800#	830	1"	T5	48x38	M12x30	M8x48
STDB Gate	150-800#	830	1.25"	T25	54x44	M12x35	M10x58
STDB Gate	150-800#	830	1.50"	T6	66x54	M14x35	M10x60
STDB Gate	150-800#	830	2"	T27	74x50	M16x40	M10x60

Note: STDB = Standard Bore

VALVE TYPE	CLASS	BASE FIGURE NO	NPS	PACKING CODE	GASKET CODE	BONNET CAPSCREW	GLAND STUD
STDB Check	150-800#	840, 850, 860	0.50"	-	40x30	M10x25	-
STDB Check	150-800#	840, 850, 860	0.75"	-	40x30	M10x25	-
STDB Check	150-800#	840, 850, 860	1"	-	48x38	M12x30	-
STDB Check	150-800#	840, 850, 860	1.25"	-	54x44	M12x35	-
STDB Check	150-800#	840, 850, 860	1.50"	-	66x54	M14x35	-
STDB Check	150-800#	840, 850, 860	2"	-	74x50	M16x40	-

Note: STDB = Standard Bore



ANGLE VALVES

We manufacture Angle Globe valves in various configurations for pressure reduction, High Temperature service, Boiler and Drainage use. Our valves have a wide application in the Power Generation industry in steam services.

- **Service:**
Blowoff and Blowdown
- **Standards:**
ASME (ANSI), ISO
- **Range:**
½" to 4", #1500 - # 4500
High Pressure, High Temperature



SELF CLOSING VALVES

Our range of Self Closing Globe valves includes Angle Type and Bellows Seal. The spring mechanism is integrated to the bonnet and is designed to resist heavy usage.

- **Service:**
Spring Operated Self Closing
- **Standards:**
ASME (ANSI), ISO
- **Range:**
1/2" to 2", #150 - #4500



VERTICAL CHECK VALVES

We offer Ball Check valves for vertical line installation.

Compact forged design in 2 pieces

- **Service:**
Vertical line service
- **Standards:**
ASME (ANSI), ISO
- **Range:**
1/2" to 2", #800/#1500 SW/NPT
- **Model N°:**
#800: UV650
#1500: UV950

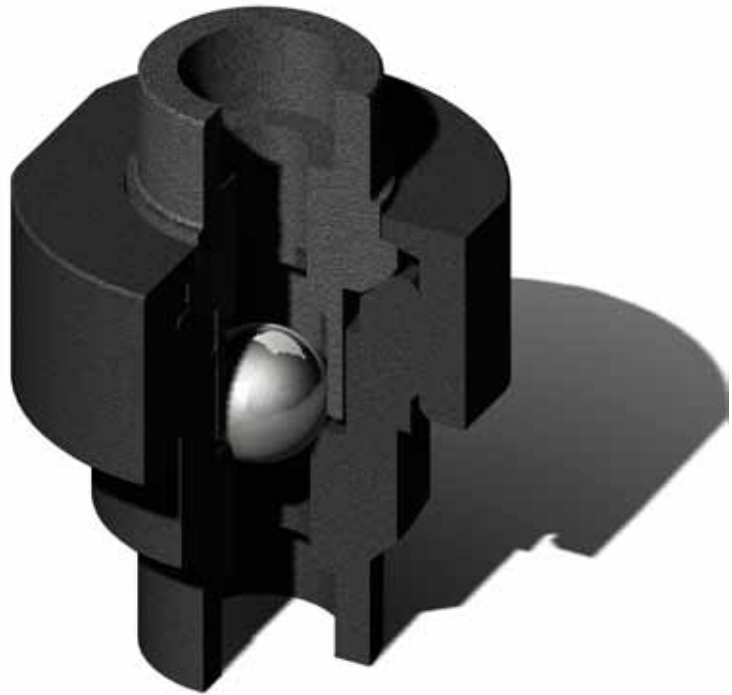

VALVES WITH ACTUATOR

We can supply all OMB's Gate and Globe valves with an Electrical, Pneumatic or Hydraulic actuator.

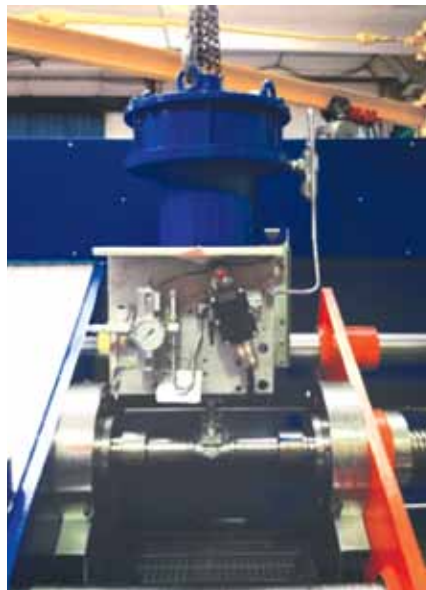
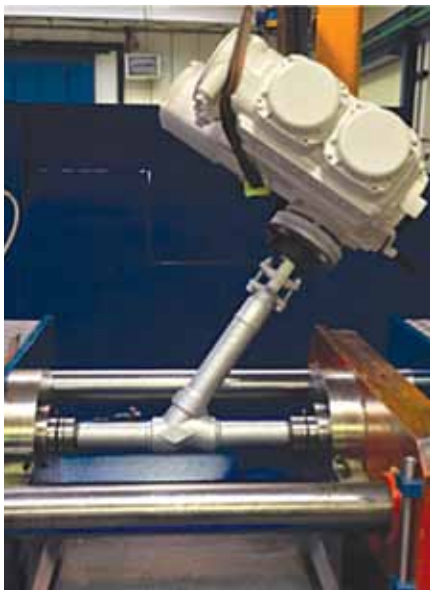

NAMEPLATE

Each valve is identified by proper marking on the name plate according to MSS SP25 and ISO15761 specifications.

Nameplate contains information regarding valve type, body-bonnet material, seat-wedge and stem composition, Class and diameter. On the nameplate the relevant mark is incorporated.

Each valve when tested is stamped on the nameplate with the QC operator code for reference.



BODY MARKING

Material designation and heat codes are forged on both body and bonnet.

Bodies are marked with the OMB logo, pressure Class designation, nominal size (using NPS number) and an arrow on check and globe valves (unidirectional).

Upon customer request further marking can be applied.



ADDITIONAL TAGS

Upon request valves can be supplied with tags based on customer specification to provide easier identification of products.



PHOSPHATIZING OF CS VALVES

All OMB's carbon and alloy steel bodies and bonnets undergo a photosphatization process according to the following table.



PHOSPHATIZING SPECIFICATION (ZINC BASE) FOR CARBON STEEL PROTECTION			
Bath	Type of operation Product used	Min. time	Temp. °C
1	Alkaline degreasing - Italbonder 011	8"	95°
2	Cold washing - Water air (current)	1"-3"	20°
3	Bonderizing - Bonder A2 - PS	8"-10"	80°
4	Cold washing - Water air (current)	1"-3"	20°
5	Oiling - Emulsifiable protoil RE	3"	50°
6	Drying	5"	20°

Phosphatization is carried out on all forged bodies and bonnets in carbon and alloy steel.

PICKLING OF SS VALVES

All OMB's stainless steel valves undergo a pickling process in a concentrated acid solution which cleans perfectly the surface of the components and allows a visual inspection of each piece.

RUST PREVENTION AND SHIPPING

All valves are shipped in wooden crates seaworthy with end protection cups in plastic and a rust prevention fluid applied in the valves internal parts. In case of special applications valves can be prepared for transportation in accordance to customer specifications.



INSTALLATION, OPERATION AND MAINTENANCE MANUALS

MANUAL REQUEST

(send a copy of this page with your request to +39.035.942638)

- OMB GGC**
Installation and Maintenance
- OMB BELLOWS**
Seal Valves Installation and Maintenance

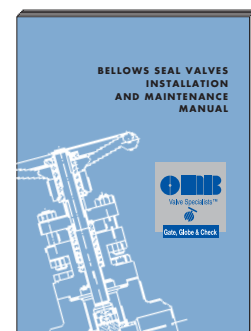

PRESSURE 1 kg/cm² = 142233 lb/in²
 1 lb/in² = 0,07037 kg/cm²

TEMPERATURE °F = + 32 T_(°F) = 9/5 x T_(°C) + 32
 °C = - 32 T_(°C) = 9/5 x (T_(°F) - 32)

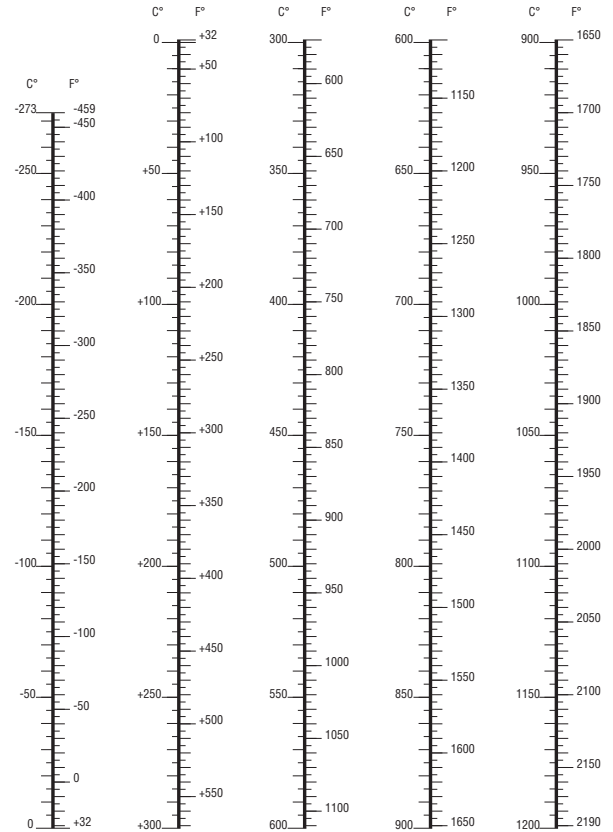
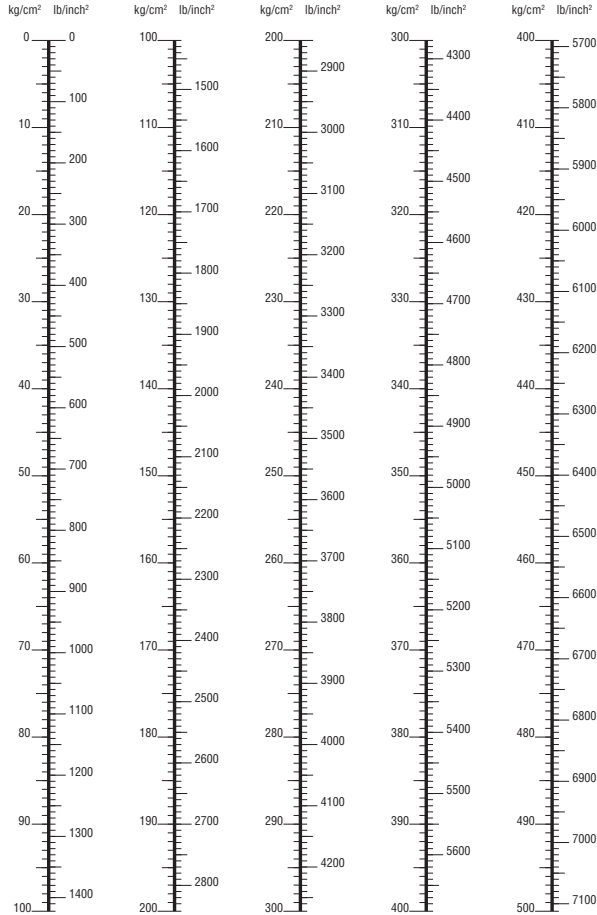

Fraction of 1 inch into decimal (in) and millimeters (mm)

FRACTION	INCH.	MILLIM.
1/64	0.016	0.397
1/32	0.031	0.794
3/64	0.047	1.191
1/16	0.062	1.587
5/64	0.078	1.984
3/32	0.094	2.381
7/64	0.109	2.778
1/8	0.125	3.175
9/64	0.141	3.572
5/32	0.156	3.969
11/64	0.172	4.365
3/16	0.187	4.762
13/64	0.203	5.159
7/32	0.219	5.556
15/64	0.234	5.953
1/4	0.250	6.350

FRACTION	INCH.	MILLIM.
17/64	0.266	6.747
9/32	0.281	7.141
19/64	0.297	7.541
5/16	0.312	7.937
21/64	0.328	8.334
11/32	0.344	8.731
23/64	0.359	9.128
3/8	0.375	9.525
25/64	0.391	9.922
13/32	0.406	10.319
27/64	0.422	10.716
7/16	0.437	11.112
29/64	0.453	11.509
15/32	0.469	11.906
31/64	0.484	12.303
1/2	0.500	12.700

FRACTION	INCH.	MILLIM.
33/64	0.516	13.097
17/32	0.531	13.494
35/64	0.547	13.891
5/8	0.562	14.287
37/64	0.578	14.684
19/32	0.594	15.081
39/64	0.609	15.478
5/8	0.625	15.875
41/64	0.641	16.272
21/32	0.656	16.669
43/64	0.672	17.066
11/16	0.687	17.462
45/64	0.703	17.859
23/32	0.719	18.256
47/64	0.734	18.653
3/4	0.750	19.050

FRACTION	INCH.	MILLIM.
49/64	0.766	19.447
25/32	0.781	19.844
51/64	0.797	20.241
13/16	0.812	20.637
53/64	0.828	21.034
27/32	0.844	21.431
55/64	0.859	21.828
7/8	0.875	22.225
57/64	0.891	22.622
29/32	0.906	23.019
59/64	0.922	23.406
15/16	0.937	23.812
61/64	0.953	24.209
31/32	0.969	24.606
63/64	0.984	25.003
1	1.000	25.400





Lined area for notes, consisting of horizontal blue lines on a white background.



HEADQUARTERS

Via Europa, 7 - 24069 Cenate Sotto (Bg) - Italy
Phone +39 035 425 67 11 - Fax +39 035 942 638
rfq@ombvalves.com - www.ombvalves.com

PLANTS

-  **OMB Valves s.p.a**
Cenate Sotto, BG - ITALY
www.ombvalves.com
-  **OMB Valves Asia Pte. Ltd.**
Woodlands - SINGAPORE
www.ombasia.com
-  **Calobri srl**
Settimo Milanese, MI - ITALY
www.calobri.com
-  **OMB Valves Inc.**
Stafford, TX - USA
www.ombvalves.com
-  **OMK Valves Co Ltd**
Gimpo - KOREA
www.ombvalves.com
-  **IVM OMB Saudi**
Al Khobar - SAUDI ARABIA
www.ivm-ombsaudi.com
-  **VOGT Valves Inc.**
Stafford, TX - USA
www.vogtvalves.com
-  **Fluicon Valves srl**
Cenate Sotto, BG - ITALY
www.fluicon.com
-  **SPSV**
Al Khobar - SAUDI ARABIA
www.spsv-sa.com

REPRESENTATIVE OFFICE:

-  **OMB Offshore Application Ltd.**
Dundee, SCOTLAND - UK
London, ENGLAND - UK
-  **OMB Valves DMCC**
Dubai - UAE
-  **OMB Valves**
Seoul - KOREA
-  **OMB Valves**
Montréal - CANADA
-  **OMB Valves**
Tokyo - JAPAN
-  **OMB Valves**
Beijing - CHINA



Worldwide Network of Agents and Distributors

Local Agent: