

Butterfly Valves



For any situation, condition, application, you can find the best with KITZ valves.

The butterfly valve, in comparison to other ordinary valves, has structural advantages such as simple construction, compact and light weight, and being piping work friendly, as well as various functional advantages, such as suitability for automated operation by open/close with 90-degree action and excellent fluid controllability, so that it is adopted in vast fields.

KITZ established a rich product lineup by preparing systematic series in accordance with application of butterfly valves in order to meet a wide variety of user needs. The KITZ butterfly valve series that realized a rich line-up = high quality = immediate delivery system meets inquiries from any type of piping line with excellent function and performance.

* Please contact us for the delivery schedule of different products.

contents

	Product Range	2
	Fluid / Material Matrix	4
	Bolt and Nut	5
	Pipe	7
	Expansion Indicator	7
	XJ Series	8
	DJ Series	16
	UB Series	24
	THROTTROL (HRDJ)	27
	D-Damper/A-Damper	30
	KITZ Butter Series (FV/UV)	33
	Precautions	35

* The figures and images in this catalogue are the typical sizes of the products. The shape or structure of each products are different depending on its size. Please request the drawings for detail.

Product Coding

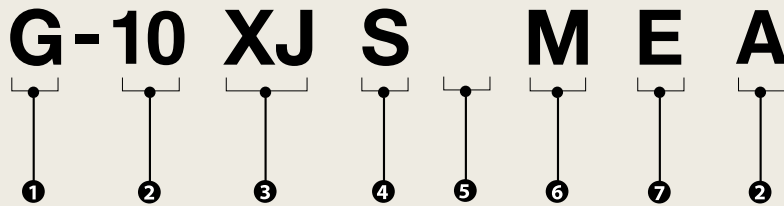

1 Valve operation

- None Lever
- G Gear
- GL Long gear
- VG Vartical gear
- FA Pneumatic actuator (Double action)
- FAS Pneumatic actuator (Spring return action)
- EXS100/200 Type EXS KELMO® electric actuator (Reversible type)
- EXD100/200 Type EXD KELMO® electric actuator (Proportional control type)
- EXCN100/200 Type EXCN KELMO® electric actuator (Proportional control type)

2 Class

- 150 ASME 150 psi
- 200 ASME 200 psi
- 250 ASME 250 psi
- PN16 EN PN16
- PN25 EN PN25
- 10 JIS 10K
- 10└─A JIS 10K/ASME Class 150
- 16 JIS 16K
- 20 JIS 20K

3 Valve series

- XJ Aluminum die-cast XJ Series
- DJ Ductile iron DJ series
- UB Stainless steel UB Series

4 Design

- None Long neck
- S Short neck

5 Connection

- None Wafer
- L Lugged

6 Disc material

- None Ductile iron (Ni-plated)
- U 304 stainless steel
- M 316 stainless steel

7 Seat material

- None NBR (Buna-N)
- E EPDM

Product Range

Series	Class	Operator	Product code	mm	15	20	25	32	40	
				inch	1/2	3/4	1	1 1/4	1 1/2	
XJ	10K	Lever	10XJME						●	
		Gear	G-10XJME						●	
		Pneumatic actuator	FA-10XJME							●
			FAS-10XJME							●
		Electric actuator	EXS ■ -10XJME						●	
		Lever	10XJSME						●	
		Gear	G-10XJSME						●	
		Pneumatic actuator	FA-10XJSME							●
			FAS-10XJSME							●
	Electric actuator	EXS ■ -10XJSME						●		
	EN PN16	Lever	PN16XJME							
		Gear	G-PN16XJME							
	JIS10K/ASME 150	Lever	10XJMEA						●	
		Gear	G-10XJMEA						●	
		Pneumatic actuator	FA-10XJMEA							
			FAS-10XJMEA							
Electric actuator	EXS ■ -10XJMEA									
DJ	ASME150/200/250	Lever	200/250DJ □□							
		Gear	G-150/200/250DJ □□ *1							
			VG-150/200/250DJ □□ *1							
	EN PN16	Lever	PN16DJ □□							
		Gear	G-PN16DJ □□							
	VG-PN16DJ □□									
	EN PN25	Lever	PN25DJ □ E							
		Gear	G-PN25DJ □ E							
	10K	Lever	10DJ □□							
		Gear	G-10DJ □□							
			VG-10DJ □□							
	16K	Lever	16DJ □□							
		Gear	G-16DJ □□							
			VG-16DJ □□							
20K	Lever	20DJ □ E								
	Gear	G-20DJ □ E								
DJL	ASME150/200/250	Lever	150/200/250DJL □□							
		Gear	G-150/200/250DJL □□							
	EN PN16	Lever	PN16DJL □□							
		Gear	G-PN16DJL □□							
	EN PN25	Lever	PN25DJL □ E							
		Gear	G-PN25DJL □ E							
UB	10K	Lever	10UB							
		Long gear	GL-10UB							
	16K	Long gear	GL-16UB							
		ASME150	Lever	150UB						
Long gear	GL-150UB									
HRDJ	10K	Gear	G-10HRDJUE							
		Electric actuator	EXCN ■ -10HRDJUE							
			EXD ■ -10HRDJUE							
	20K	Gear	G-20HRDJUE							
Electric actuator		EXCN ■ -20HRDJUE								
EXD ■ -20HRDJUE										
Damper	10K	Lever	10D							
		Long gear	GL-10D							
		Lever	10A							
		Long gear	GL-10A							
KITZ BUTTER	7.5K	Lever	FV	●	●	●	●	●		
		UV	●	●	●	●	●			

■ Power sources of actuator coding. Please refer to page 1.
□ Disc and seat material coding. Please refer to page 1.

Product Range

50	65	80	100	125	150	200	250	300	350	400	450	500	600	Page
2	2 1/2	3	4	5	6	8	10	12	14	16	18	20	24	
•	•	•	•	•	•									11
•	•	•	•	•	•	•	•	•						13
•	•	•	•	•	•	•	•	•						15
•	•	•	•	•	•									12
•	•	•	•	•	•	•	•	•						16
•	•	•	•	•	•	•	•	•						15
•	•	•*2	•	•*2	•									11
•	•	•*2	•	•*2	•	•*2								
•	•	•*3	•*3	•	•	•*3								13
•	•	•*3	•*3	•	•	•*3	•							
•	•	•*3	•*3	•	•	•*3	•							15
•	•	•*3	•*3	•	•	•*3	•							18
•	•	•	•	•	•	•	•	•	•	•	•	•	•	19
•	•	•	•	•	•	•	•	•	•	•	•	•	•	21
•	•	•	•	•	•	•	•	•	•	•	•	•	•	18
•	•	•	•	•	•	•	•	•	•	•	•	•	•	20
•	•	•	•	•	•	•	•	•	•	•	•	•	•	21
•	•	•	•	•	•	•	•	•	•	•	•	•	•	18
•	•	•	•	•	•	•	•	•	•	•	•	•	•	20
•	•	•	•	•	•	•	•	•	•	•	•	•	•	19
•	•	•	•	•	•	•	•	•	•	•	•	•	•	20
•	•	•	•	•	•	•	•	•	•	•	•	•	•	21
•	•	•	•	•	•	•	•	•	•	•	•	•	•	19
•	•	•	•	•	•	•	•	•	•	•	•	•	•	20
•	•	•	•	•	•	•	•	•	•	•	•	•	•	21
•	•	•	•	•	•	•	•	•	•	•	•	•	•	19
•	•	•	•	•	•	•	•	•	•	•	•	•	•	20
•	•	•	•	•	•	•	•	•	•	•	•	•	•	22
•	•	•	•	•	•	•	•	•	•	•	•	•	•	23
•	•	•	•	•	•	•	•	•	•	•	•	•	•	22
•	•	•	•	•	•	•	•	•	•	•	•	•	•	23
•	•	•	•	•	•	•	•	•	•	•	•	•	•	22
•	•	•	•	•	•	•	•	•	•	•	•	•	•	23
•	•	•	•	•	•	•	•	•	•	•	•	•	•	26
•	•	•	•	•	•	•	•	•	•	•	•	•	•	
•	•	•	•	•	•	•	•	•	•	•	•	•	•	29
•	•	•	•	•	•	•	•	•	•	•	•	•	•	
•	•	•	•	•	•	•	•	•	•	•	•	•	•	
•	•	•	•	•	•	•	•	•	•	•	•	•	•	
•	•	•	•	•	•	•	•	•	•	•	•	•	•	31
•	•	•	•	•	•	•	•	•	•	•	•	•	•	32
•	•	•	•	•	•	•	•	•	•	•	•	•	•	
•	•	•	•	•	•	•	•	•	•	•	•	•	•	34
•	•	•	•	•	•	•	•	•	•	•	•	•	•	

*1: 200 psi and 250 psi for size 2 to 12. 150 psi for size 14 to 24.

*2: Centering sleeves are supplied for accurate centering with EN1092 PN16 flanges.

*3: Centering sleeves are optionally available for accurate centering with ASME class 150 flanges.

Corrosion resistance level of materials of disc and seat against fluid

This table shows applicability of representative fluids against each disc/rubber seat material. Please refer to the Cautions for Product Selection of the Cautions for Handling at the end of this material for other cautions. Also, contact us for any questions because temperature and operational condition may cause some differences.

Fluid	Material	Materials of wetted part (disc or body material for UB/FV/UV)				Sheat material		
		FCD450	SCS13A	SCS14A	C37771BE	NBR	EPDM*	PTFE
Sulfurous acid		×	○	○	◎	△	△	◎
Ammonia (anhydrous liquid)		○	◎	◎	—	△	○	◎
Ammonia (solution)		○	◎	◎	◎	○	○	◎
Ethane		○	○	○	—	◎	×	◎
Ethyl alcohol		○	◎	◎	◎	○	◎	◎
Hydrochloric acid		×	×	×	◎	△	○	◎
Sea water		×	○	○	◎	◎	◎	◎
Gasoline (refined/unieaded)		○	◎	◎	◎	△	×	◎
Air		◎	◎	◎	◎	◎	◎	◎
Mineral oil		○	◎	◎	◎	◎	×	◎
Heavy oil (A,B,C)		△	◎	◎	◎	×	×	◎
Acetic acid (10%)		△	◎	◎	◎	×	○	◎
Oxgen (cold)		○	◎	◎	◎	○	○	◎
Lubricating oil (petroleum base)		◎	◎	◎	◎	◎	×	◎
Vegitable oil		△	◎	◎	◎	◎	△	◎
Steam (100°C)		◎	◎	◎	○	×	○	◎
Hydrogen gas (cold)		○	◎	◎	◎	○	○	◎
Petroleum oil (refined)		—	◎	◎	◎	○	×	◎
Soybean oil		△	◎	◎	◎	◎	△	◎
Carbonic acid		×	○	○	◎	○	○	◎
Calcium carbonate		×	○	○	◎	◎	◎	◎
Natural gas		◎	◎	◎	◎	○	×	◎
Animal fat		◎	◎	◎	◎	◎	×	◎
Propane gas		○	○	◎	◎	◎	×	◎
Water (fresh <= 40°C)		△	◎	◎	◎	○	◎	◎
Water (hot <= 40-100°C)		△	◎	◎	○	×	○	◎
Methyl alcohol		○	◎	◎	◎	○	◎	◎
Sulfuric acid (7%)		×	△	○	◎	○	○	◎
Sulfuric acid (20%)		×	×	×	◎	×	○	◎
Sulfuric acid (>=50%)		×	×	×	△	×	○	◎
Ammonium sulfate		△	○	○	◎	◎	◎	◎
Products		DJ·DJL	DJ·DJL· UB·HRDJ	XJ·DJ· DJL·UV	FV	DJ·DJL	XJ·DJ·DJL HRDJ	UB

- ◎ = Excellent
- = Good
- △ = Less recommended
- ×
- = Contact us for details

* EPDM is not applicable for oil.

Allowance of differential pressure control and ratio of differential pressure control

Structure	Norminal diameter	Allowance of differential pressure control (kPa)		Ratio of different pressure
		Fluid	Gas	
Rubber sheet	50~200 ^A	200	100	0.30
	250·300 ^A	150	100	0.25
	350~600 ^A	100	50	0.20
PTFE sheet (for UB series)	50~600 ^A	300	200	0.30
Damper	50~300 ^A	—	30	0.10

[Notice]

- Contact us in the event of using at condition exceeding the values in this table.
- Control pressure difference is a pressure difference between valve primary side pressure and secondary side pressure. ($\Delta p = p_1 - p_2$)
- The pressure difference is presented by the value that the difference of pressure divided by the pressure at the primary side (absolute pressure).

Bolt/Nut

Hexagon head bolt + Hexagon nut

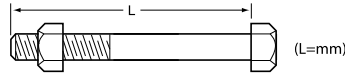

*Size 24" requires additional hexagon head bolts.

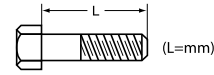

Hexagon head bolt + Hexagon nut for XJ series/DJ series/HRDJ series (mm)																					
Flange		ASME Class 150/200/250				EN PN10			EN PN16			EN PN25			JIS 10K			JIS 16K/20K			
inch	mm	Size	L (inch/mm)	Number	Size	L	Number	Size	L	Number	Size	L	Number	Size	L	Number	Size	L(16K)	L(20K)	Number	
2	50	5/8	4.25	108	4	M16	105	4	M16	105	4	M16	110	4	M16	95	4	M16	95	100	8
2 1/2	65	5/8	4.75	121	4	M16	105	4	M16	105	4	M16	115	8	M16	105	4	M16	105	105	8
3	80	5/8	4.75	121	4	M16	105	8	M16	105	8	M16	120	8	M16	105	8	M20	110	115	8
4	100	5/8	5.00	127	8	M16	115	8	M16	115	8	M20	130	8	M16	110	8	M20	120	125	8
5	125	3/4	5.25	133	8	M16	115	8	M16	115	8	M24	140	8	M20	120	8	M22	125	140	8
6	150	3/4	5.50	140	8	M20	120	8	M20	120	8	M24	145	8	M20	125	8	M22	130	140	12
8	200	3/4	5.75	146	8	M20	130	8	M20	130	12	M24	150	12	M20	130	12	M22	140	150	12
10	250	7/8	6.50	165	12	M20	140	12	M24	150	12	M27	170	12	M22	150	12	M24	150	170	12
12	300	7/8	7.00	178	12	M20	155	12	M24	160	12	M27	180	16	M22	160	16	M24	170	180	16
14	350	1	7.50	191	12	M20	155	16	M24	170	16	—	—	—	M22	160	16	M30X3	180	180	16
16	400	1	8.50	216	16	—	—	—	M27	200	16	—	—	—	M24	190	16	M30X3	210	220	16
18	450	1 1/8	9.25	235	16	—	—	—	M27	210	20	—	—	—	M24	210	20	M30X3	230	240	20
20	500	1 1/8	10.25	260	20	—	—	—	M30	230	20	—	—	—	M24	220	20	M30X3	250	260	20
24	600	1 1/4	11.75	298	20	—	—	—	M33	270	20	—	—	—	M30	260	20	M36X3	290	300	20
																70*	8*		90*	100*	8*

Stud bolt + Hexagon nut

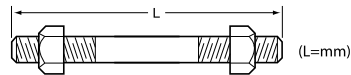

*Size 24" requires additional hexagon head bolts.

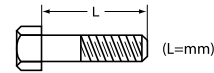

Stud head bolt + Double hexagon nut for DJ series/HRDJ series (mm)																					
Flange		ASME Class 150/200/250				EN PN10			EN PN16			EN PN25			JIS 10K			JIS 16K/20K			
inch	mm	Size	L (inch/mm)	Number	Size	L	Number	Size	L	Number	Size	L	Number	Size	L	Number	Size	L(16K)	L(20K)	Number	
2	50	5/8	5.00	127	4	M16	125	4	M16	125	4	M16	130	4	M16	115	4	M16	120	100	8
2 1/2	65	5/8	5.25	133	4	M16	130	4	M16	130	4	M16	140	8	M16	120	4	M16	120	105	8
3	80	5/8	5.25	133	4	M16	130	8	M16	130	8	M16	150	8	M16	120	8	M20	140	115	8
4	100	5/8	5.75	146	8	M16	135	8	M16	135	8	M20	150	8	M16	130	8	M20	140	125	8
5	125	3/4	6.25	159	8	M16	140	8	M16	140	8	M24	160	8	M20	145	8	M22	150	140	8
6	150	3/4	6.50	165	8	M20	145	8	M20	145	8	M24	170	8	M20	150	8	M22	160	140	12
8	200	3/4	6.75	171	8	M20	155	8	M20	150	12	M24	180	12	M20	155	12	M22	160	150	12
10	250	7/8	7.50	191	12	M20	170	12	M24	170	12	M27	200	12	M22	170	12	M24	180	170	12
12	300	7/8	8.00	203	12	M20	185	12	M24	190	12	M27	210	16	M22	180	16	M24	190	180	16
14	350	1	8.75	222	12	M20	185	16	M24	190	16	—	—	—	M22	180	16	M30X3	210	180	16
16	400	1	9.75	248	16	—	—	—	M27	220	16	—	—	—	M24	220	16	M30X3	240	220	16
18	450	1 1/8	10.75	273	16	—	—	—	M27	240	20	—	—	—	M24	230	20	M30X3	260	240	20
20	500	1 1/8	11.50	292	20	—	—	—	M30	260	20	—	—	—	M24	250	20	M30X3	280	260	20
24	600	1 1/4	13.25	337	20	—	—	—	M33	300	20	—	—	—	M30	290	20	M36X3	320	300	20
																70*	8*		90*	100*	8*

* The sizes are applied to both the hexagon bolt with nut and the hexagon head bolt (set bolt).

Lugged type

Hexagon head bolt for DJL (mm)																
Flange		ASME Class 150/200/250				EN PN10			EN PN16			EN PN25				
inch	mm	Size	L (inch/mm)	Number	Size	L	Number	Size	L	Number	Size	Steel		Ductile	Number	
												L	L			
2	50	5/8	1.375	35	8	M16	38	8	M16	38	8	M16	40	40	8	
2 1/2	65	5/8	1.500	38	8	M16	40	8	M16	40	8	M16	40	40	16	
3	80	5/8	1.625	41	8	M16	40	16	M16	40	16	M16	45	40	16	
4	100	5/8	1.875	48	16	M16	40	16	M16	40	16	M20	45	40	16	
5	125	3/4	1.875	48	16	M16	40	16	M16	40	16	M24	50	45	16	
6	150	3/4	2.000	51	16	M20	45	16	M20	45	16	M24	50	45	16	
8	200	3/4	2.125	54	16	—	—	—	M20	45	24	M24	55	50	24	
10	250	7/8	2.375	60	24	—	—	—	M24	53	24	M27	60	55	24	
12	300	7/8	2.625	67	24	—	—	—	M24	60	24	M27	65	60	32	
14	350	1	2.750	70	24	—	—	—	M24	60	32	—	—	—	—	
16	400	1	3.000	76	32	—	—	—	M27	70	32	—	—	—	—	
18	450	1 1/8	3.375	86	32	—	—	—	M27	75	40	—	—	—	—	
20	500	1 1/8	3.500	89	40	—	—	—	M30	80	40	—	—	—	—	
24	600	1 1/4	4.000	102	40	—	—	—	M33	90	40	—	—	—	—	

Hexagon head bolts.

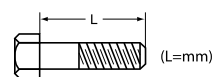

Double bolt

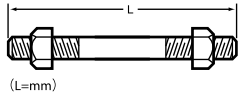

Double bolt for XJ series (mm)										
Flange		ASME Class 150			EN1092 PN 16			JIS 10K		
mm	inch	Size	L	Number	Size	L	Number	Size	L	Number
40	1½	—	—	—	—	—	—	M16	105	4
50	2	5/8-11	120	4	M16	125	4	M16	115	4
65	2½	5/8-11	130	4	M16	130	4	M16	120	4
80	3	5/8-11	130	4	M16	130	8	M16	120	8
100	4	5/8-11	145	8	M16	135	8	M16	130	8
125	5	3/4-10	160	8	M16	140	8	M20	145	8
150	6	3/4-10	160	8	M20	145	8	M20	150	8
200	8	3/4-10	170	8	M20	155	12	M20	155	12
250	10	7/8-9	190	12	—	—	—	M22	170	12
300	12	—	—	—	—	—	—	M22	180	16

Hexagon headbolts

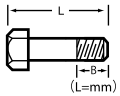

Hexagon head bolt + Hexagon nut for UB series (mm)													
Flange		JIS 10K				JIS 16K				AS ME Class 150			
mm	inch	Size	L	B	Number	Size	L	B	Number	Size	L	B	Number
50	2	M16	100	38	4	M16	100	38	4	5/8	105	38	4
65	2½	M16	110	38	4	M16	110	38	4	5/8	110	38	4
80	3	M16	110	38	8	M20	120	46	8	5/8	115	38	4
100	4	M16	115	38	8	M20	130	52	8	5/8	130	44	8
125	5	M20	130	52	8	M22	130	56	8	3/4	140	52	8
150	6	M20	130	52	8	M22	140	56	8	3/4	140	52	8
200	8	M20	150	52	12	M22	160	56	12	3/4	160	52	8
250	10	M22	160	56	12	M24	170	60	12	7/8	180	56	12
300	12	M22	170	56	16	M24	180	60	16	7/8	190	56	12
350	14	M22	180	56	16	M30x3	200	72	16	1	200	60	12
400	16	M24	200	60	16	M30x3	220	85	16	1	220	79	16
450	18	M24	210	73	16	M30x3	240	85	16	1 1/8	240	85	16
			68*	54*	8*		80*	66*	8*				
500	20	M24	220	73	16	M30x3	250	85	16	1 1/8	260	85	16
			60*	54*	8*		70*	66*	8*				
550	22	—	—	—	—	—	—	—	—	—	—	—	—
600	24	M30	260	85	20	M36x3	290	97	20	1 1/4	300	91	16
			78*	66*	8*		90*	78*	8*				

* The sizes are applied to both the hexagon bolt with nut and the hexagon head bolt (set bolt).

Hexagon head bolt + Hexagon nut for D/A type damper (mm)										
Flange		JIS 5K				JIS 10K				
mm	inch	Size	L	B	Number	Size	L	B	Number	
50	2	M12	90	30	4	M16	100	38	4	
65	2½	M12	100	30	4	M16	110	38	4	
80	3	M16	110	38	8	M16	120	38	8	
100	4	M16	120	38	8	M16	130	38	8	
125	5	M16	130	38	8	M20	140	52	8	
150	6	M16	140	38	8	M20	150	52	8	
200	8	M20	150	52	12	M20	160	52	12	
250	10	M20	170	52	12	M22	180	56	12	
300	12	M20	180	52	16	M22	190	56	16	

These sizes for UB series and D/A type damper are the size of bolt with a gasket of 3 mm.

Pipe

When butterfly valves are being opened, movement of discs may be interrupted by pipe internals. Where butterfly valves are connected with welded pipe flanges shown in the right illustration, use of pipes given in the right table is recommended. Valve-to-flange centering work must be always accurately done on valve mounting on pipelines.

Double welding

Valve Series		XJ Series			DJ Series			UB Series			D/A Damper		
mm	inch	SGP	Schedule		SGP	Schedule		SGP	Schedule		SGP	Schedule	
			20	40		20	40		20	40		20	40
40	1 1/2	●	●	●	●	—	●	—	—	—	—	—	—
50	2	●	●	●	●	●	●	●	●	●	●	●	●
65	2 1/2	●	●	●	●	●	●	●	●	●	●	●	●
80	3	●	●	●	●	●	●	●	●	●	●	●	●
100	4	●	●	●	●	●	●	●	●	●	●	●	●
125	5	●	●	●	●	●	●	●	●	●	●	●	●
150	6	●	●	●	●	●	●	●	●	●	●	●	●
200	8	●	●	●	●	●	●	●	●	●	●	●	●
250	10	●	●	●	●	●	●	●	●	●	●	●	●
300	12	●	●	●	●	●	●	●	●	●	●	●	●
350	14	—	—	—	●	●	●	—	—	●	—	—	—
400	16	—	—	—	●	●	●	—	—	●	—	—	—
450	18	—	—	—	●	●	●	—	—	●	—	—	—
500	20	—	—	—	●	●	●	—	—	●	—	—	—
550	22	—	—	—	—	●	●	—	—	—	—	—	—
600	24	—	—	—	—	●	—	—	—	●	—	—	—

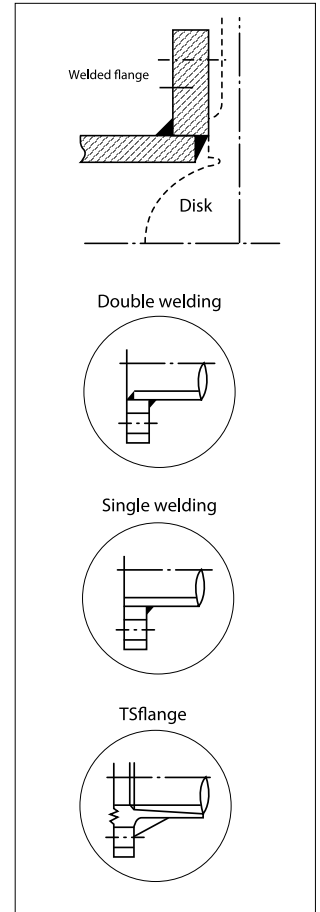

Single welding / TS flange

Valve Series		XJ Series			DJ Series			UB Series			D/A Damper						
mm	inch	SGP	Schedule		TS	SGP	Schedule		TS	SGP	Schedule		TS	SGP	Schedule		
			20	40			20	40			20	40			20	40	
40	1 1/2	●	●	●	●	●	—	●	●	—	—	—	—	—	—	—	—
50	2	●	●	●	●	●	●	●	●	●	●	●	●	●	●	●	●
65	2 1/2	●	●	●	●	●	●	●	●	●	●	●	●	●	●	●	●
80	3	●	●	●	●	●	●	●	●	●	●	●	●	●	●	●	●
100	4	●	●	●	●	●	●	●	●	●	●	●	●	●	●	●	●
125	5	●	●	●	●	●	●	●	●	●	●	●	●	●	●	●	●
150	6	●	●	●	×	●	●	×	●	●	●	×	●	●	●	●	●
200	8	●	●	●	×	●	●	×	●	●	●	×	●	●	●	●	●
250	10	●	●	●	×	●	●	×	●	●	●	×	●	●	●	×	●
300	12	●	●	●	×	●	●	×	●	●	●	×	●	●	●	×	●
350	14	—	—	—	—	●	●	—	—	—	—	—	—	—	—	—	—
400	16	—	—	—	—	●	●	—	—	—	—	—	—	—	—	—	—
450	18	—	—	—	—	●	●	—	—	—	—	—	—	—	—	—	—
500	20	—	—	—	—	●	●	—	—	—	—	—	—	—	—	—	—
550	22	—	—	—	—	—	●	—	—	—	—	—	—	—	—	—	—
600	24	—	—	—	—	—	●	—	—	—	—	—	—	—	—	—	—

Sizes of Lined Steel Pipes

In case of vinyl chloride lined steel pipes, sizes of flanges must be larger than the minimum inside diameters given in the right table. In case of pulverulent polyethylene of the pipes lined steel pipes, no special care is needed.

Valve Series	Size	A	40	50	65	80	100	125	150	200	250	300	350	400	450	500	550	600
		B	1 1/2	2	2 1/2	3	4	5	6	8	10	12	14	16	18	20	22	24
XJ Series			28	30	50	70	90	116	144	194	244	292	—	—	—	—	—	—
DJ Series			28	32	52	75	92	118	145	195	244	292	332	379	427	473	513	566
UJ Series			—	43	57	71	88	118	140	190	239	281	327	373	424	471	—	567
D/A Damper			—	36	53	69	86	119	139	190	240	288	—	—	—	—	—	—

Note: Connecting a pipe with a diameter at or less than the value in the table above may cause interference of the pipe and the disc.

Indicator

● Optional component to extend the indicator for displaying degree of opening to outside of a lagging material in the event of insulating including gear unit.

Valve Series		G-10XJ	G-10DJ	G-16DJ	G-20DJ	G-10/16/150 UB	G-10HRDJ
Size							
40 ^A	1 1/2 ^B	B OS SET1	B OS SET1	—	B OS SET1	OS SET1	B OS SET1
50	2						
65	2 1/2						
80	3						
100	4						
125	5						
150	6						
200	8						
250	10						
300	12						
350	14	—	B OS SET1 *1	B OS SET1 *2	OS SET2	—	
400	16	—	OS SET2	OS SET3	—	—	
450	18	—	—	—	—	—	
500	20	—	OS SET3	OS SET4	—	—	
550	22	—	—	—	—	—	
600	24	—	OS SET3	OS SET4	—	OS SET5	

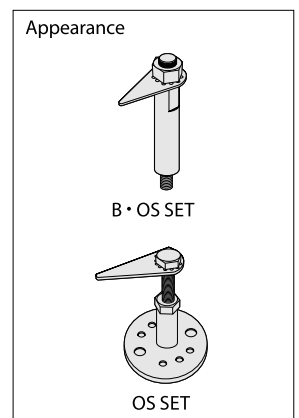

*1 Indicator for mounting on G - 10DJ series. Contact us for products with different material/paint/connection, because there may be a case to use OS SET2CJ.
 *2 Indicator for mounting on G - 16DJ series. Contact us for products with different material/paint/connection, because there may be a case to use OS SET2.

KITZ XJ series aluminum butterfly valves:
Featuring a unique style for the neck designs (U.S.P. No. 6676109) to accommodate various piping designs, piping positions, and installation environments.

Specification

Class	JIS 10K	Class 150	PN16
Maximum service pressure	1MPa	1MPa	1.6MPa (16bar)
Service temperature range*1	-20°C to +120°C		
Continuous service temperature range*2	-20°C to +100°C		
Face-to-face dimension	API609, BS5155 (Short pattern) ISO 5752-20, JIS B 2002 46 series		
Coupling flanges	JIS B 2220 / 2239 10K	ASME Class 150 JIS B 2220 / 2239 10K	EN1092 PN16*3

*1 Condition : Fluid is not frozen.

*2 Refer to P-T rating chart.

*3 With centering sleeves.

Refer to the product range chart in page 2 and precaution in page 36 for details.

Cv value

Size		Cv	Size		Cv
A	B		A	B	
40	1 1/2	76	125	5	1100
50	2	99	150	6	1820
65	2 1/2	205	200	8	2780
80	3	372	250	10	4350
100	4	723	300	12	6860

Feature

Your choice of two neck designs

A long neck type and a short neck type are available for use in a variety of applications.

Easy valve-to-flange centering

The light weight of the die-cast aluminum valve body (which is only one third of the weight of KITZ's conventional cast-iron butterfly valves) eases valve-to-flange centering work on mounting valves on pipelines.

Wide range of service applications

Austenitic stainless steel discs and EPDM* rubber seats can handle many different types of line fluid without risk of corrosion.

Stabilized operating torque

A pair of stem bearings assembled around the top and bottom stems prevents stem galling and stabilizes the valve operating torque for smooth and trouble-free disc rotation.

On-the-spot actuator assembly

The actuator mounting pads of all necks are designed in conformity with ISO 5211 requirements for direct on-site mounting of actuators that are provided with ISO 5211 valve mounting flanges.

Prevention of dew condensation (Long neck type)

A long stainless steel neck blocks transfer of fluid heat to the valve operating device, so no insulation is needed on the operating device. Dew condensation is also minimized for gear-operated valves used in cold water service.

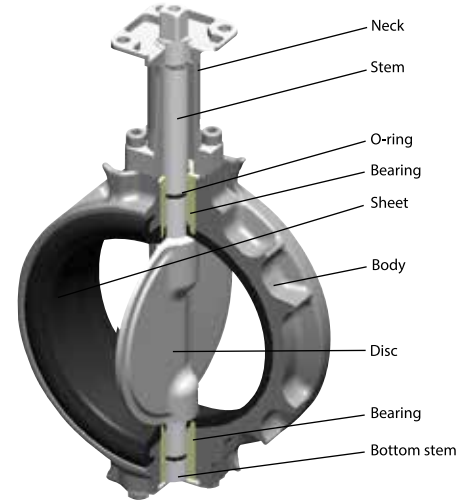

Standard Materials

*Please refer to the drawing of deliverables for detail.

Parts	Materials
Body	Aluminum die-cast/equivalent ASTM B85-84-383.0
Neck	304 stainless steel
Stem	(Equivalent ASTM A276 type 410)
Disk	A351 Gr. CF8M
O-ring	EPDM
Rubber seat	EPDM
Bottom stem	(Equivalent ASTM A276 type 410)
Bearing	Metal backed PTFE (size 10" and 12") Polyphenylenesulfide (10XJMEA: size 1 1/2" to 8") Bronze: CAC401C (PN16XJME: size 2" to 8")

Rust prevention

The main parts such as the stems, discs, necks, neck connectors, and endplates and small parts such as stopper plates, washers, and boltings are all made of stainless steel for high-grade rust prevention.

S-shaped spherical disc for high sealing performance (patented)

KITZ's original cross-sectionally S-shaped valve discs with spherical surfaces make evenly tight contact with rubber liners for excellent sealing performance with reduced operating torque. Complete 360° shut-off mechanisms help to extend the service life of rubber liners. (Size: ≥2 inches)

Carefully designed KITZ EPDM seats have the following unique features that ensure their functional stability, high sealing performance, and long life:

- Self-reinforced ribbing
 - Wide disc seating contact
 - Dual stem seal bearings
- ① Wide disc seating contact for high sealing performance.
 - ② Reinforced ribbing minimizes valve operating problems such as distortion, skidding, and exfoliation of rubber liners caused by line pressure load and friction with metal discs.
 - ③ Stem seal bearings are assembled on the top and bottom stems for stable sealing.
 - ④ Gasketless flange sealing contact for easy valve mounting.

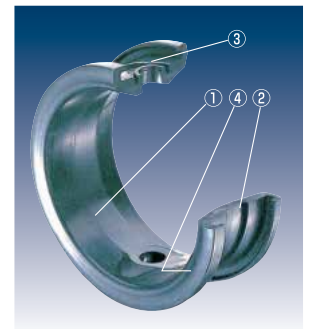

P-T Rating

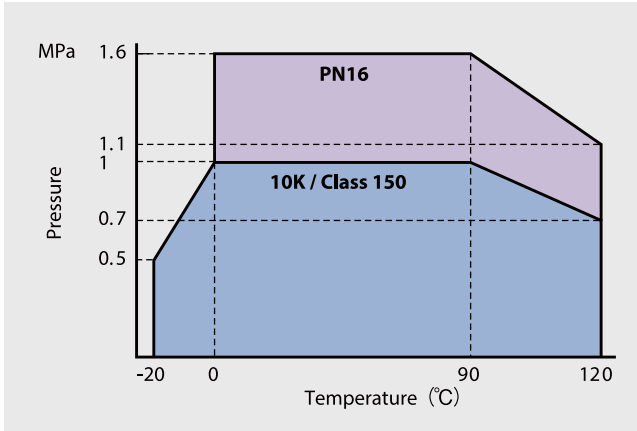

Flow Characteristics

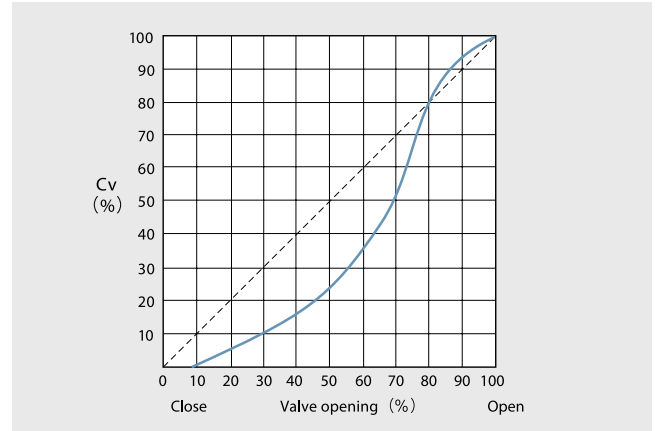

Pressure Loss

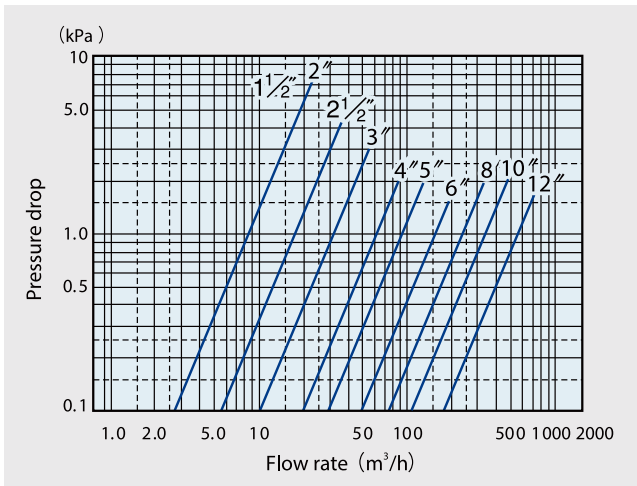

Long Neck Type

Prevented dew condensation



Feature

- A long stainless steel neck reduces the conductivity of fluid heat and prevents dew condensation.
- Variety of valve body and neck insulation designs available.
- Choice of actuators for automated valve operation.

Application

- Building utilities
- Piping networks for cold water, hot water, and other water supply

Valve Insulation

Insulation is recommended for areas in blue.

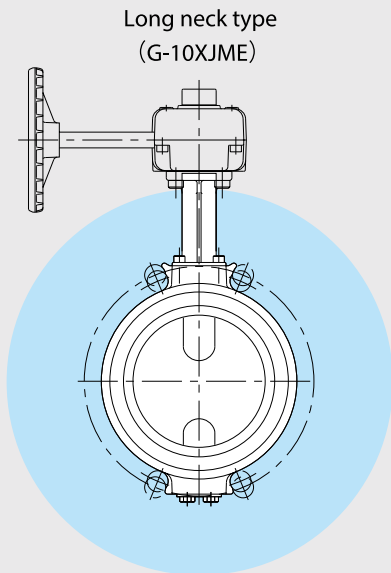

Note: It is not available in short neck type.

Short Neck Type

Compact design



Feature

- Suitable for piping in a limited space.
- Choice of actuators for automated valve operation.

Application

- Building utilities
- Plant facilities
- Water treatment facilities
- Industrial machinery operation

Dew Condensation Test

Samples of KITZ XJ series butterfly valves equipped with long necks (KITZ Product Code: G-10XJMEA) were tested at the KITZ Laboratory under the conditions listed below. The lower surface temperatures of gear boxes, ambient temperatures, and ambient humidities were measured as the variable functions. The dew condensation boundary was estimated as illustrated below.

G-10XJME Estimated Dew Condensation Boundary

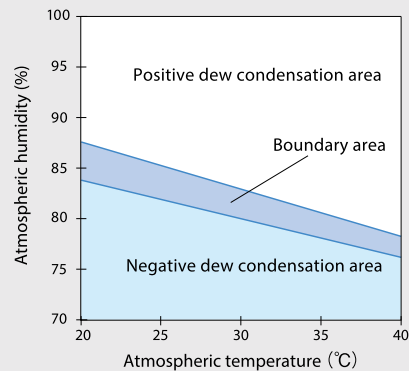

Test condition

- Line fluid: +5°C cold water
- Atmospheric temperature range: +20°C to +40°C
- Valve insulation: 50-mm glass wool (JIS A 9501) around the test valve, with gear boxes exposed to open air.

Note:

The estimation shown here is the result of a summary of tests carried out within a test basin at a constant temperature and humidity and does not necessarily represent the absolute values. Note that the dew condensation prevention properties of these valves may be affected by changes in the test conditions, such as the variation in the degree of air transfer, line fluid temperature, atmospheric humidity, or condition of insulation. Acceptance of an allowance of ±5% beyond the boundary area is recommended.

Long Neck Type Lever Operated

10XJME
10XJMEA
PN16XJME

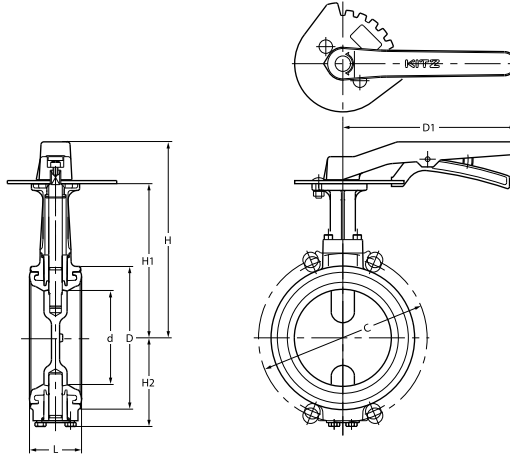

Dimensions

unit : mm

Size		d	H	H1	H2	L	D	C			D1
mm	inch							10K	Class 150	PN16	
40	1½	40	172	128	40	33	80	105	98.5	—	180
50	2	50	176	132	66	43	93	120	120.5	125	180
65	2½	65	185	141	74	46	118	140	139.5	145	180
80	3	80	193	149	83	46	129	150	152.5	160	180
100	4	100	204	160	94	52	149	175	190.5	180	180
125	5	125	249	195	122	56	184	210	216	210	230
150	6	150	261	207	135	56	214	240	241.5	240	230
200	8	196	281	234	161	60	258	—	298.5	—	350

Long Neck Type Gear Operated

G-10XJME
G-10XJMEA
G-PN16XJME

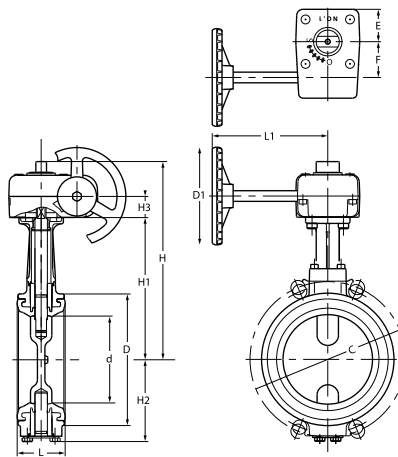

Dimensions

unit : mm

Size		d	H	H1	H2	H3	L	D	C			D1	L1	E	F	Gear type
mm	inch								10K	Class150	PN16					
40	1½	40	175	128	40	19	33	80	105	98.5	—	80	122	29	28	No.0
50	2	50	179	132	66	19	43	93	120	120.5	125	80	122	29	28	No.0
65	2½	65	188	141	74	19	46	118	140	139.5	145	80	122	29	28	No.0
80	3	80	196 *2	149	83	19	46	129	150	152.5	160	80	122	29	28	No.0
100	4	100	223	160	94	24	52	149	175	190.5	180	110	135	36	40	No.1
125	5	125	258	195	122	24	56	184	210	216	210	110	150	36	40	No.1
150	6	150	270	207	135	24	56	214	240	241.5	240	110	150	36	40	No.1
200	8	196	311	234	161 *1	32	60	258	290	298.5	295	170	180	51	63	No.2
250	10	245	405	328	238	32	68	316	355	362	—	170	180	51	63	No.2
300	12	295	430	353	263	32	78	367	400	—	—	170	180	51	63	No.2

*1 G-PN16XJME H2=183
*2 G-PN16XJME H=212

Short Neck Type Lever Operated

10XJSME

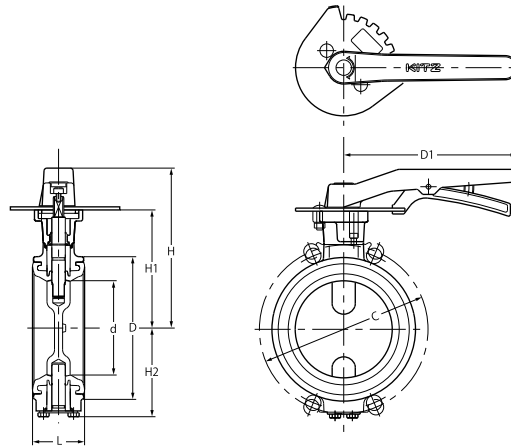

■ Dimensions

unit : mm

Size		d	H	H1	H2	L	D	C	D1
mm	inch								
40	1½	40	137	93	40	33	80	105	180
50	2	50	139	95	66	43	93	120	180
65	2½	65	147	103	74	46	118	140	180
80	3	80	156	112	83	46	129	150	180
100	4	100	167	123	94	52	149	175	180
125	5	125	205	151	122	56	184	210	230
150	6	150	217	163	135	56	214	240	230

Short Neck Type Gear Operated

G-10XJSME

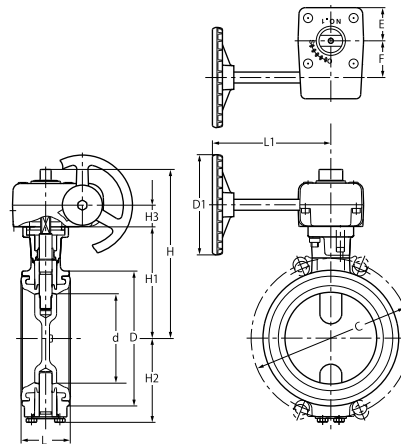

■ Dimensions

unit : mm

Size		d	H	H1	H2	H3	L	D	C	D1	L1	E	F	Gear type
mm	inch													
40	1½	40	140	93	40	19	33	80	105	80	122	29	28	No.0
50	2	50	142	95	66	19	43	93	120	80	122	29	28	No.0
65	2½	65	150	103	74	19	46	118	140	80	122	29	28	No.0
80	3	80	159	112	83	19	46	129	150	80	122	29	28	No.0
100	4	100	186	123	94	24	52	149	175	110	135	36	40	No.1
125	5	125	214	151	122	24	56	184	210	110	150	36	40	No.1
150	6	150	226	163	135	24	56	214	240	110	150	36	40	No.1
200	8	196	267	190	161	32	60	258	290	170	180	51	63	No.2
250	10	245	317	239	238	32	68	316	355	170	180	51	63	No.2
300	12	295	342	264	263	32	78	367	400	170	180	51	63	No.2

Long Neck Type

Pneumatically Operated - Double Action Actuator

FA-10XJME
FA-10XJMEA

● Size 1 1/2" to 8"

● Size 10" to 12"

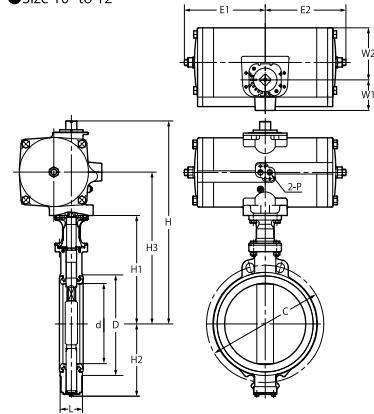
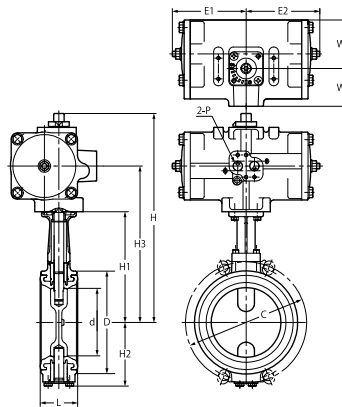

Please contact the KITZ Corporation for actuator specifications.

Dimensions

unit : mm

Size		d	H	H1	H2	H3	L	D	C		Actuator					
mm	inch								10K	Class150	E1	E2	W1	W2	P	Type
40	1 1/2	40	251	128	40	181	33	80	105	—	87	87	50	54	Rc 1/4	FA-1
50	2	50	255	132	66	185	43	93	120	120.5	87	87	50	54	Rc 1/4	FA-1
65	2 1/2	65	287	141	74	207	46	118	140	139.5	107	107	54	70	Rc 1/4	FA-2
80	3	80	295	149	83	215	46	129	150	152.5	107	107	54	70	Rc 1/4	FA-2
100	4	100	306	160	94	226	52	149	175	190.5	107	107	54	70	Rc 1/4	FA-2
125	5	125	357	195	122	271	56	184	210	216	128	128	57	87	Rc 1/4	FA-3
150	6	150	369	207	135	283	56	214	240	241.5	128	128	57	87	Rc 1/4	FA-3
200	8	196	435	234	161	327	60	258	290	298.5	160	160	68	111	Rc 1/4	FA-4
250	10	245	573	328	238	441	68	316	355	362	208	208	78	135	Rc 1/4	FA-5
300	12	295	627	353	263	475	78	367	400	—	268	268	101	178	Rc 1/4	FA-6

Long Neck Type

Pneumatically Operated - Spring Return Action Actuator

FAS-10XJME
FAS-10XJMEA

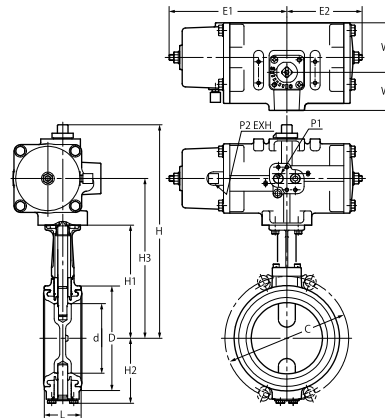

Please contact the KITZ Corporation for actuator specifications.

Dimensions

unit : mm

Size		d	H	H1	H2	H3	L	D	C		Actuator						
mm	inch								10K	Class150	E1	E2	W1	W2	P1	P2	Type
40	1 1/2	40	274	128	40	194	33	80	105	—	166	107	54	70	Rc 1/4	Rc 1/8	FAS-2
50	2	50	278	132	66	198	43	93	120	120.5	166	107	54	70	Rc 1/4	Rc 1/8	FAS-2
65	2 1/2	65	303	141	74	217	46	118	140	139.5	203	128	57	87	Rc 1/4	Rc 1/8	FAS-3
80	3	80	311	149	83	225	46	129	150	152.5	203	128	57	87	Rc 1/4	Rc 1/8	FAS-3
100	4	100	364	160	94	256	52	149	175	190.5	290	160	68	111	Rc 1/4	Rc 1/8	FAS-4
125	5	125	396	195	122	288	56	184	210	216	290	160	68	111	Rc 1/4	Rc 1/8	FAS-4
150	6	150	452	207	135	320	56	214	240	241.5	363	208	78	135	Rc 1/4	Rc 1/8	FAS-5
200	8	196	511	234	161	359	60	258	290	298.5	483	268	101	178	Rc 1/4	Rc 1/8	FAS-6

Short Neck Type

Pneumatically Operated - Double Action Actuator

FA-10XJSME



● Size 1 1/2" to 8"

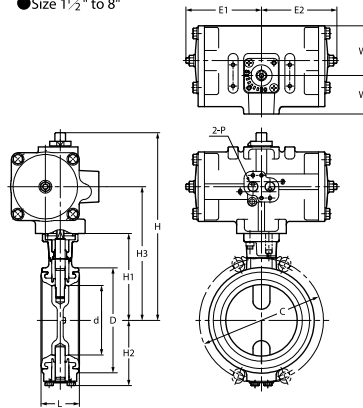

● Size 10" to 12"

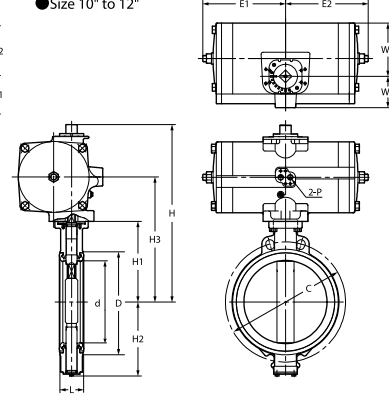

Please contact the KITZ Corporation for actuator specifications.

Dimensions

unit : mm

Size		d	H	H1	H2	H3	L	D	C	Actuator					
mm	inch									E1	E2	W1	W2	P	Type
40	1 1/2	40	216	93	40	146	33	80	105	87	87	50	54	Rc 1/4	FA-1
50	2	50	218	95	66	148	43	93	120	87	87	50	54	Rc 1/4	FA-1
65	2 1/2	65	249	103	74	169	46	118	140	107	107	54	70	Rc 1/4	FA-2
80	3	80	258	112	83	178	46	129	150	107	107	54	70	Rc 1/4	FA-2
100	4	100	269	123	94	189	52	149	175	107	107	54	70	Rc 1/4	FA-2
125	5	125	313	151	122	227	56	184	210	128	128	57	87	Rc 1/4	FA-3
150	6	150	325	163	135	239	56	214	240	128	128	57	87	Rc 1/4	FA-3
200	8	196	391	190	161	283	60	258	290	160	160	68	111	Rc 1/4	FA-4
250	10	245	483	238	238	351	68	316	355	208	208	78	135	Rc 1/4	FA-5
300	12	295	537	263	263	385	78	367	400	268	268	101	178	Rc 1/4	FA-6

Short Neck Type

Pneumatically Operated - Spring Return Action Actuator

FAS-10XJSME

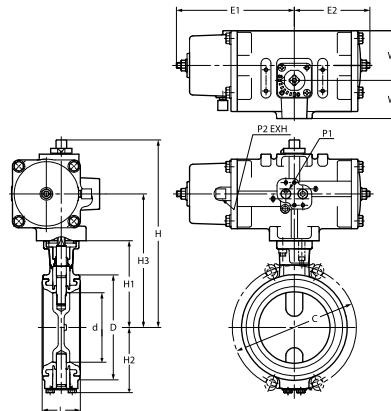

Please contact the KITZ Corporation for actuator specifications.

Dimensions

unit : mm

Size		d	H	H1	H2	H3	L	D	C	Actuator						
mm	inch									E1	E2	W1	W2	P1	P2	Type
40	1 1/2	40	239	93	40	159	33	80	105	166	107	54	70	Rc 1/4	Rc 1/8	FAS-2
50	2	50	241	95	66	161	43	93	120	166	107	54	70	Rc 1/4	Rc 1/8	FAS-2
65	2 1/2	65	265	103	74	179	46	118	140	203	128	57	87	Rc 1/4	Rc 1/8	FAS-3
80	3	80	274	112	83	188	46	129	150	203	128	57	87	Rc 1/4	Rc 1/8	FAS-3
100	4	100	327	123	94	219	52	149	175	290	160	68	111	Rc 1/4	Rc 1/8	FAS-4
125	5	125	352	151	122	244	56	184	210	290	160	68	111	Rc 1/4	Rc 1/8	FAS-4
150	6	150	408	163	135	276	56	214	240	363	208	78	135	Rc 1/4	Rc 1/8	FAS-5
200	8	196	467	190	161	315	60	258	290	483	268	101	178	Rc 1/4	Rc 1/8	FAS-6

Aluminum Butterfly Valves

XJ series

Long Neck Type Electrically Operated

EXS-10XJME
EXS-10XJMEA

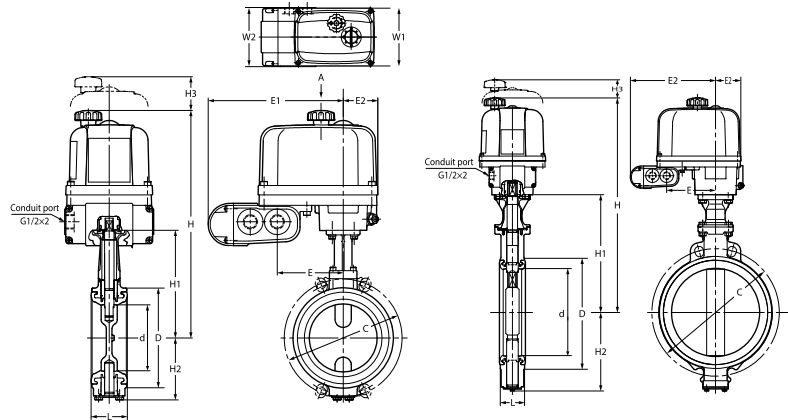

Please contact the KITZ Corporation for actuator specifications.

Dimensions

unit : mm

Size		d	H	H1	H2	L	D	C		Actuator						
mm	inch							10K	Class150	E	E1	E2	W1	W2	H3	Type
40	1 1/2	40	309	128	40	33	80	105	-	98	206.5	54	131	132	107.5	EXS-2
50	2	50	313	132	66	43	93	120	120.5	98	206.5	54	131	132	107.5	EXS-2
65	2 1/2	65	322	141	74	46	118	140	139.5	98	206.5	54	131	132	107.5	EXS-2
80	3	80	330	149	83	46	129	150	152.5	98	206.5	54	131	132	107.5	EXS-2
100	4	100	341	160	94	52	149	175	190.5	98	206.5	54	131	132	107.5	EXS-2
125	5	125	401	194.5	122	56	184	210	216	121.5	230	69	158	132	117.5	EXS-3
150	6	150	413.5	207	135	56	214	240	241.5	121.5	230	69	158	132	117.5	EXS-3
200	8	196	440	233.5	161	60	258	290	298.5	121.5	230	69	158	132	117.5	EXS-3
250	10	245	604	328	238	68	316	355	362	137	245.5	73	188	132	153	EXS-4
300	12	295	629	353	263	78	367	400	-	137	245.5	73	188	132	153	EXS-4

Power sources of actuator coding. Please refer to page 1.

Short Neck Type Electrically Operated

EXS-10XJSME

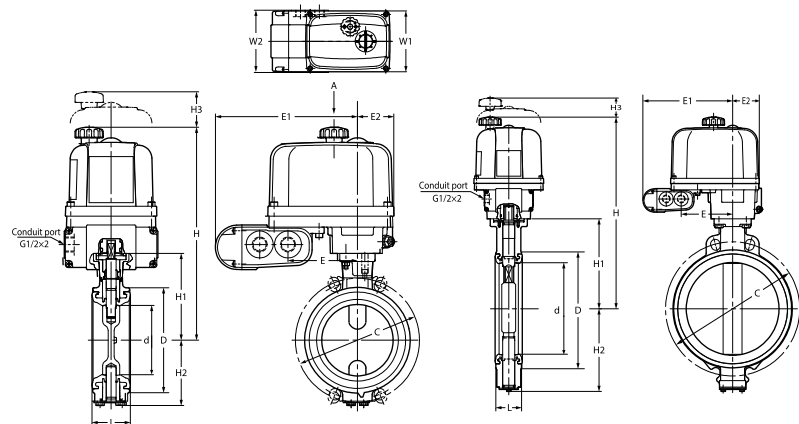

Please contact the KITZ Corporation for actuator specifications.

Dimensions

unit : mm

Size		d	H	H1	H2	L	D	C	Actuator						
mm	inch								E	E1	E2	W1	W2	H3	Type
40	1 1/2	40	274	93	40	33	80	105	98	206.5	54	131	132	107.5	EXS-2
50	2	50	276	95	66	43	93	120	98	206.5	54	131	132	107.5	EXS-2
65	2 1/2	65	284	103	74	46	118	140	98	206.5	54	131	132	107.5	EXS-2
80	3	80	293	112	83	46	129	150	98	206.5	54	131	132	107.5	EXS-2
100	4	100	304	123	94	52	149	175	98	206.5	54	131	132	107.5	EXS-2
125	5	125	357.5	151	122	56	184	210	121.5	230	69	158	132	117.5	EXS-3
150	6	150	369.5	163	135	56	214	240	121.5	230	69	158	132	117.5	EXS-3
200	8	196	396.5	190	161	60	258	290	121.5	230	69	158	132	117.5	EXS-3
250	10	245	514	238	238	68	316	355	137	245.5	73	188	132	153	EXS-4
300	12	295	539	263	263	78	367	400	137	245.5	73	188	132	153	EXS-4

Power sources of actuator coding. Please refer to page 1.

Through pursuit of functions required for butterfly valves. Variety of product range to comply with user's requirements.

Specification

Maximum service pressure			
ASME 150	1.03MPa	10K	1.0 MPa
ASME 200	1.38MPa	16K	1.6 MPa
ASME 250	1.72MPa	20K	2.0 MPa
PN16	1.6 MPa		
PM25	2.5 MPa		

Service temperature range	
NBR (Buna-N) seat	0°C to +70°C
EPDM seat	-20°C to +130°C *
Continuous service temperature range	0°C to +100°C

* There are some fluid type restrictions for the service at 130°C. Contact us for details.

Applicable standards	
Valve design	API 609, MSS-SP 67, EN 593, JIS B 2032
Face to face dimensions	API 609 Category A, MSS-SP 67 W-1: Size 2 to 14 W-2: Size 16 to 24 EN 558 basic series 20, ISO 5752 20 Series, JIS B 2002 46 Series

Coupling flanges	
Wafer type	ASME Class 150/200/250 EN 1092 PN10: DN 50 to DN 350, PN16: All sizes PN25: DN 50 to DN 300 BS 10 Table D/Table E JIS 10K/16K/20K
Lugged type	ASME Class 150/200/250 EN 1092 PN10: DN 50 to DN 150, PN16: All sizes PN25: DN 50 to DN 300

Feature

Non-peeling Seat-to-body Construction

Molded-in (bonded) seat structure is employed for size 2 to 12. Larger sized valves are provided with replaceable seat. This non-peeling seat-to-body construction assures maintenance-free application for high fluid velocity service*1, vacuum service*2 and handling surging fluid velocity. It also guarantees peel-free valve mounting on pipelines.

*1 Maximum 4 meters/second for on-off service for valves up to size 12, and 3 meters/second for size 14 and larger.

*2 Up to 30 Torr. Vacuum service is option for size 14 and larger.

Spherical Design for Discs and Seats

Rubber seats are spherically designed where they contact top and bottom stems. This protects widely designed rubber seats from peeling or deformation for prolonged service life of valves. Thinly streamlined metal discs are the results of elaborate laboratory study to ultimately minimize the pressure loss.

Choice of Materials and Operating Devices

Choice among 4 disc and 2 seat materials and manual, pneumatic or electric valve operating devices makes service applications highly versatile.

Integral ISO 5211 Actuator Mounting Flange

Any pneumatic or electric valve actuators provided with ISO 5211 valve mounting flanges can be easily mounted for actuation of valves in the field.

Low Valve Operating Torque

Low operating torques are designed low for extension of valve service life and economic consideration in selection of valve operating devices.

Light-designed for Operation Efficiency

Designed much lighter than our conventional series for operation efficiency in piping

Emission-free Stem Sealing Mechanism

Prevention of external fluid leakage is maximized with a rubber O-ring assembled around the top stem and tight contact between spherically designed rubber seat and spherically designed top and bottom end of the disc.

Dew Condensation Prevention

Dew condensation prevention type is optionally available with heat insulating plate (size 2 to 6) or stainless steel stand (size 8 to 24).

Molded-in (bonded) seat structure (Size 2 to 12)*1

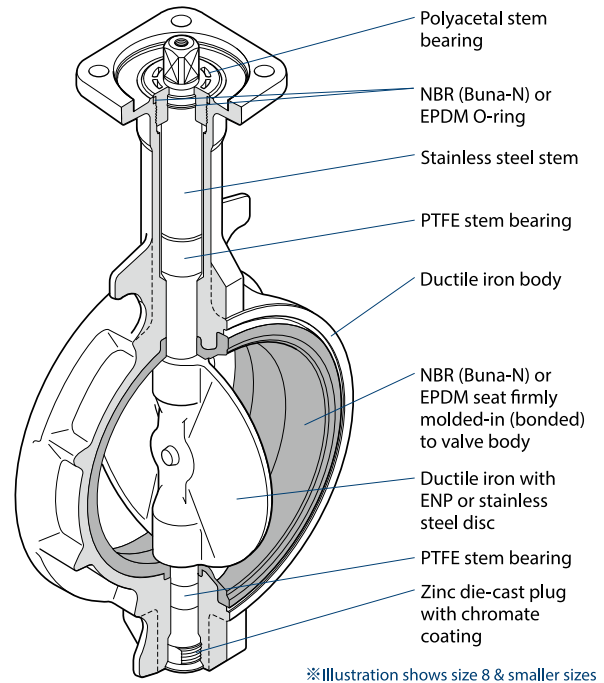

Replaceable seat structure (Size 14 to 24)*2

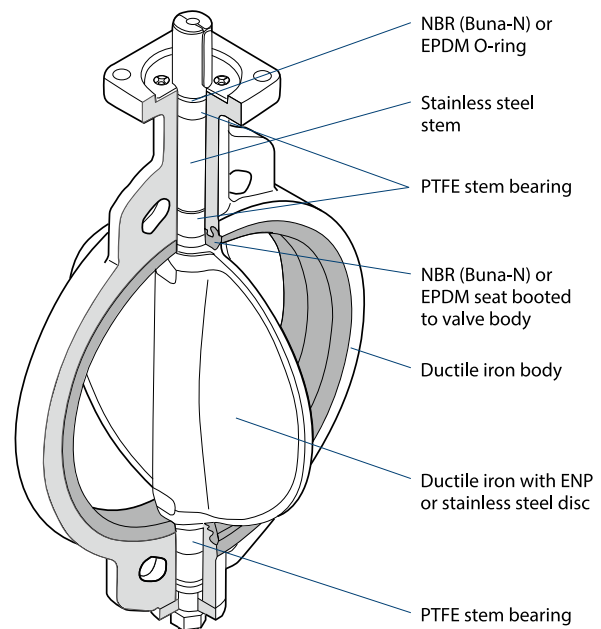

Flow Coefficient (Cv)

Size		Valve opening			
inch	mm	30°	45°	60°	90°
2	50	10	23	47	124
2½	65	22	50	102	270
3	80	33	74	149	397
4	100	55	125	252	671
5	125	83	189	381	1013
6	150	126	286	576	1532
8	200	230	522	1050	2792
10	250	325	743	1514	4025
12	300	493	1123	2260	6010
14	350	617	1371	2829	7525
16	400	826	1787	3760	10080
18	450	1076	2441	4933	13120
20	500	1311	2969	6012	15990
24	600	1942	4449	8907	23690

Pressure Loss

(for handling static clean water with valve fully open)

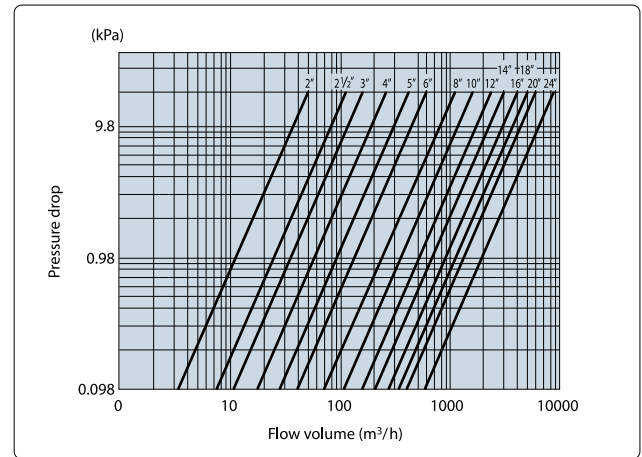

P-T Rating

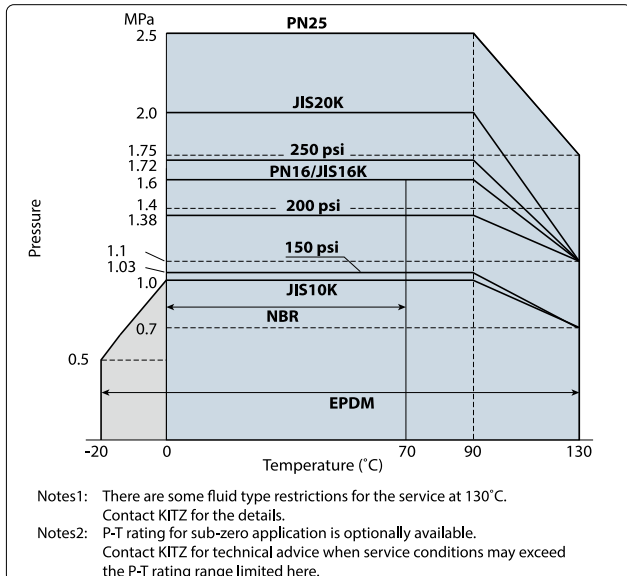

Flow Characteristics

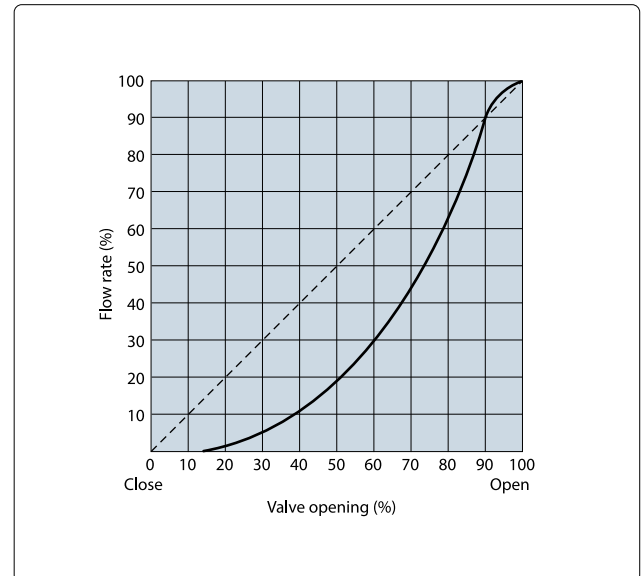

Standard Materials

Parts	Material	
Body	Ductile Iron	
	Cast Iron (JIS 10K design Size 14" to 24")	
Stem Bottom stem	410 Stainless Steel / 420 Stainless Steel	
Disc	Ductile Iron (Ni-plated) / 304SS / 316SS / Aluminum Bronze (See Explanation of Product Code)	
Seat O-ring	NBR (Buna-N) / EPDM (See Explanation of Product Code)	
Bearing	Polyacetal / Glass Filled PTFE / Metal Backed PTFE	
Plug (Size 2" to 8")	Zinc die-cast (Chromate Coating)	
Operator	Lever	Aluminum Die-cast
	Gear	Aluminum Die-cast (Size 2" to 12") Cast-Iron (Size 14" to 24")
	Vertical gear	Cast-Iron

Wafer Type

ASME 200/250 psi Design - Lever Operated

200DJ

250DJ

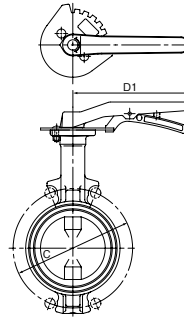
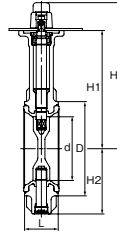

Dimensions

unit : mm

Size		d	H	H1	H2	L	D	C	D1
mm	inch								
50	2	50	191	147	67	43	90	120.5	180
65	2½	65	199	155	75	46	104	139.5	180
80	3	80	217	173	91	46	124	152.5	180
100	4	100	227	183	101	52	146	190.5	180
125	5	125	265	211	127	56	176	216	230
150	6	150	277	223	139	56	205	241.5	230
200	8	197	295	248	169	60	257	298.5	350

Disc and seat material coding. Please refer to page 1.

Wafer Type

EN PN16/25 Design - Lever Operated

PN16DJ

PN25DJ E

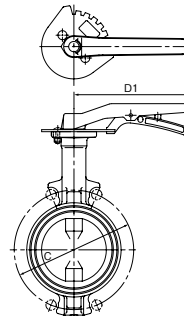
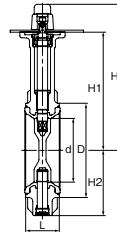

Dimensions

unit : mm

Size		d	H	H1	H2	L	D	C		D1
mm	inch							PN16	PN25	
50	2	50	191	147	67	43	90	125	125	180
65	2½	65	199	155	75	46	104	145	145	180
80	3	80	217	173	91	46	124	160	160	180
100	4	100	227	183	101	52	146	180	190	180
125	5	125	265	211	127	56	176	210	220	230
150	6	150	277	223	139	56	205	240	250	230
200	8	197	295	248	169	60	257	295	—	350

Disc and seat material coding. Please refer to page 1.

Wafer Type JIS 10K/16K/20K Design - Lever Operated

- 10DJ
- 16DJ
- 20DJ E

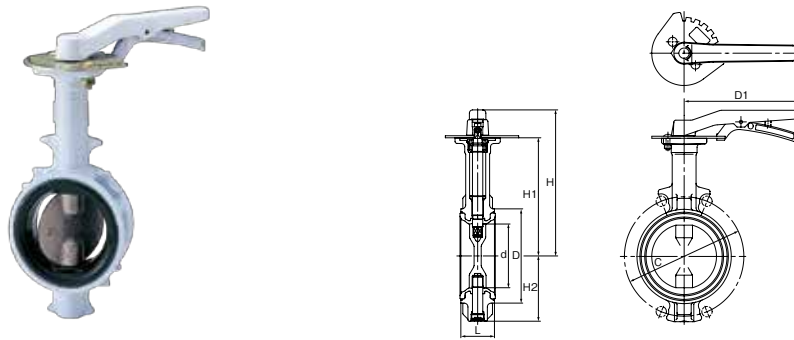

Dimensions unit : mm

Size		d	H	H1	H2	L	D	C		D1
mm	inch							10DJ	16/20DJ	
50	2	50	191	147	67	43	90	120	120	180
65	2½	65	199	155	75	46	104	140	140	180
80	3	80	217	173	91	46	124	150	160	180
100	4	100	227	183	101	52	146	175	185	180
125	5	125	265	211	127	56	176	210	225	230
150	6	150	277	223	139	56	205	240	260	230
200	8	197	295	248	169	60	257	290	305	350

Disc and seat material coding. Please refer to page 1.

Wafer Type ASME 150/200/250 psi Designe - Gear Operated

- G-150DJ
- G-200DJ
- G-250DJ

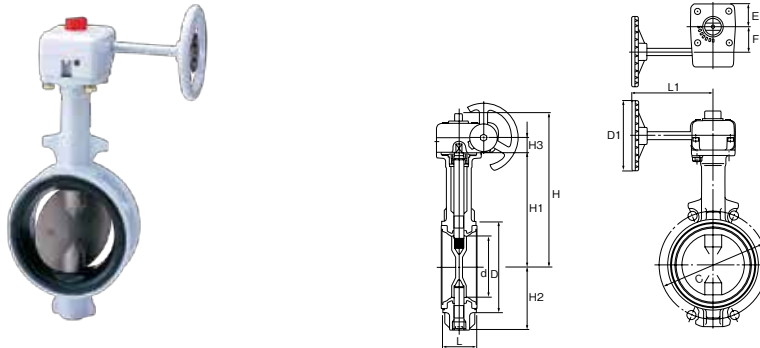

Dimensions unit : mm

Size		d	H	H1	H2	L	D	C	H3	D1	L1	E	F
mm	inch												
50	2	50	194	147	67	43	90	120.5	19	80	122	29	28
65	2½	65	202	155	75	46	104	139.5	19	80	122	29	28
80	3	80	236	173	91	46	124	152.5	24	110	135	36	40
100	4	100	246	183	101	52	146	190.5	24	110	135	36	40
125	5	125	274	211	127	56	176	216	24	110	150	36	40
150	6	150	286	223	139	56	206	241.5	24	110	150	36	40
200	8	197	325	248	169	60	257	298.5	32	170	180	51	63
250	10	246	381	304	219	68	312	362	32	170	180	51	63
300	12	295	406	329	244	78	364	432	32	170	180	51	63
350	14	334	447	360	309	78	407	476.5	47	310	220	54	66
400	16	385	502	415	341	102	466	539.5	47	310	220	54	66
450	18	434	526	439	365	114	522	578	47	310	220	54	66
500	20	482	587	488	414	127	575	635	60	500	360	68	89
600	24	579	635	536	463	154	680	749.5	60	500	360	68	89

Disc and seat material coding. Please refer to page 1.

Wafer Type

EN 16/25 JIS 10K/16K/20K Design - Gear Operated

- G-PN16DJ
- G-PN25DJ E
- G-10DJ
- G-16DJ
- G-20DJ

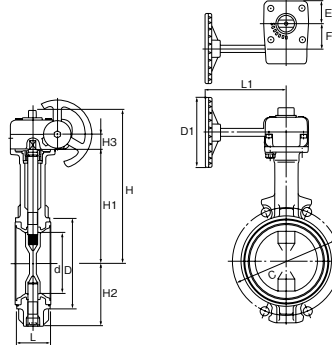

Dimensions (PN16/PN25)

unit : mm

Size		d	H	H1	H2	H3	L	D	C		D1		L1		E	F
mm	inch								PN16	PN25	PN16	PN25	PN16	PN25		
50	2	50	194	147	67	19	43	90	125	125	80	80	122	122	29	28
65	2½	65	202	155	75	19	46	104	145	145	80	80	122	122	29	28
80	3	80	236	173	91	24	46	124	160	160	110	110	135	135	36	40
100	4	100	246	183	101	24	52	146	180	190	110	110	135	135	36	40
125	5	125	274	211	127	24	56	176	210	220	110	110	150	150	36	40
150	6	150	286	223	139	24	56	206	240	250	110	110	150	150	36	40
200	8	197	325	248	169	32	60	257	295	310	170	170	180	180	51	63
250	10	246	381	304	219	32	68	312	355	370	250	250	250	250	51	63
300	12	295	406	329	244	32	78	364	410	430	250	250	250	250	51	63
350	14	334	461	360	309	60	78	407	470	—	360	—	350	—	68	89
400	16	385	516	415	348	60	102	466	525	—	360	—	350	—	68	89
450	18	434	540	439	372	60	114	522	585	—	360	—	350	—	68	89
500	20	482	623	488	423	65	127	575	650	—	500	—	400	—	90	134
600	24	579	671	536	472	65	154	680	770	—	500	—	400	—	90	134

Dimensions (10DJ)

unit : mm

Size		d	H	H1	H2	H3	L	D	C	D1	L1	E	F
mm	inch												
50	2	50	194	147	67	19	43	90	120	80	122	29	28
65	2½	65	202	155	75	19	46	104	140	80	122	29	28
80	3	80	236	173	91	24	46	124	150	110	135	36	40
100	4	100	246	183	101	24	52	146	175	110	135	36	40
125	5	125	274	211	127	24	56	176	210	110	150	36	40
150	6	150	286	223	139	24	56	206	240	110	150	36	40
200	8	197	325	248	169	32	60	257	290	170	180	51	63
250	10	246	381	304	219	32	68	312	355	170	180	51	63
300	12	295	406	329	244	32	78	364	400	170	180	51	63
350	14	333	445	360	309	47	78	407	445	310	220	54	66
400	16	385	500	415	341	47	102	466	510	310	220	54	66
450	18	434	524	439	365	47	114	522	565	310	220	54	66
500	20	482	589	488	414	60	127	575	620	360	350	68	89
600	24	579	637	536	463	60	154	680	730	360	350	68	89

Dimensions (16DJ/20DJ)

unit : mm

Size		d	H	H1	H2	H3	L	D	C	D1	L1	E	F
mm	inch												
50	2	50	194	147	67	19	43	90	120	80	122	29	28
65	2½	65	202	155	75	19	46	104	140	80	122	29	28
80	3	80	236	173	91	24	46	124	160	110	135	36	40
100	4	100	246	183	101	24	52	146	185	110	135	36	40
125	5	125	274	211	127	24	56	176	225	110	150	36	40
150	6	150	286	223	139	24	56	206	260	110	150	36	40
200	8	197	325	248	169	32	60	257	305	170	180	51	63
250	10	247	381	304	219	32	68	312	380	250	250	60	63
300	12	296	406	329	244	32	78	364	430	250	250	60	63
350	14	333	461	360	309	47	78	407	480	360	350	68	89
400	16	385	516	415	348	47	102	466	540	360	350	68	89
450	18	434	540	439	372	47	114	522	605	360	350	68	89
500	20	482	623	488	423	60	127	575	660	500	410	90	134
600	24	579	671	536	472	60	154	680	770	500	410	90	134

Disc and seat material coding. Please refer to page 1.

Wafer Type ASME 150/200/250 psi Design - Vertical Gear Operated

- VG-150DJ
- VG-200DJ
- VG-250DJ

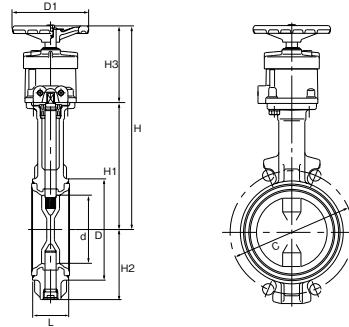

Dimensions

unit : mm

Size		d	H	H1	H2	H3	L	D	C	D1
mm	inch									
50	2	50	270	147	67	123	43	90	120.5	110
65	2½	65	278	155	75	123	46	104	139.5	110
80	3	80	285	173	91	112	46	124	152.5	110
100	4	100	295	183	101	112	52	146	190.5	110
125	5	125	325	211	127	114	56	176	216	170
150	6	150	337	223	139	114	56	206	241.5	170
200	8	197	404	248	169	156	60	257	298.5	200
250	10	247	461	304	219	157	68	312	362	310
300	12	296	486	329	244	157	78	364	432	310
350	14	333	569	360	309	209	78	407	476.5	360
400	16	385	624	415	341	209	102	466	539.5	360
450	18	434	648	439	365	209	114	522	578	360
500	20	482	741	488	414	253	127	575	635	500
600	24	579	789	536	463	253	154	680	749.5	500

□ Disc and seat material coding. Please refer to page 1.

Wafer Type JIS 10K/16K - Vertical Gear Operated

- VG-10DJ
- VG-16DJ

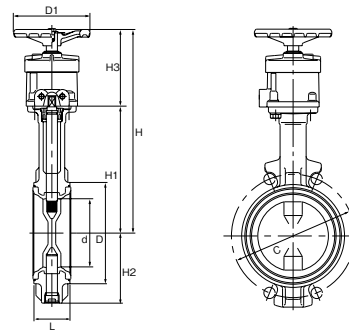

Dimensions

unit : mm

Size		d	H		H1	H2		H3		L	D	C		D1
mm	inch		10DJ	16DJ		10DJ	16DJ	10DJ	16DJ			10DJ	16DJ	
50	2	50	270	270	147	67	67	123	123	43	90	120	120	110
65	2½	65	278	278	155	75	75	123	123	46	104	140	140	110
80	3	80	285	285	173	91	91	112	112	46	124	150	160	110
100	4	100	295	295	183	101	101	112	112	52	146	175	185	110
125	5	125	325	325	211	127	127	114	114	56	176	210	225	170
150	6	150	337	337	223	139	139	114	114	56	206	240	260	170
200	8	197	404	404	248	169	169	156	156	60	257	290	305	200
250	10	247	461	461	304	219	219	157	157	68	312	355	380	310
300	12	296	486	486	329	244	244	157	157	78	364	400	430	310
350	14	333	569	569	360	309	309	209	209	78	407	445	480	360
400	16	385	624	649	415	341	348	209	234	102	466	510	540	360
450	18	434	648	673	439	365	372	209	234	114	522	565	605	360
500	20	482	741	766	488	414	423	253	278	127	575	620	660	500
600	24	579	789	814	536	463	472	253	278	154	680	730	770	500

□ Disc and seat material coding. Please refer to page 1.

Lugged Type

ASME 150/200/250 psi Design - Lever Operated

- 150DJL
- 200DJL
- 250DJL

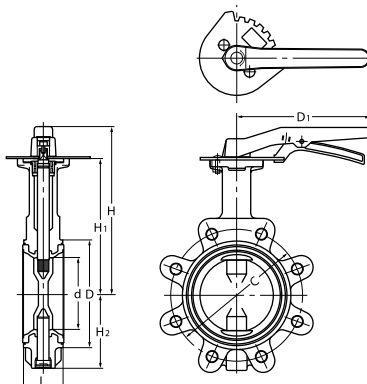

Dimensions

unit : mm

Size		d	H	H1	H2	L	D	C	D1
mm	inch								
50	2	50	191	147	67	43	90	120.5	180
65	2½	65	199	155	75	46	104	139.5	180
80	3	80	217	173	91	46	124	152.5	180
100	4	100	227	183	101	52	146	190.5	180
125	5	125	265	211	127	56	176	216	230
150	6	150	277	223	139	56	206	241.5	230
200	8	197	295	248	169	60	257	298.5	350

Disc and seat material coding. Please refer to page 1.

Lugged Type

EN PN16/PN25 Design - Lever Operated

- PN16DJL
- PN25DJL E

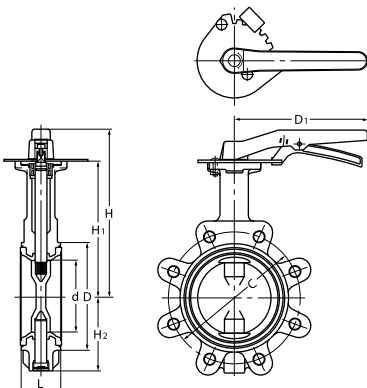

Dimensions

unit : mm

Size		d	H	H1	H2	L	D	C		D1
mm	inch							PN16	PN25	
50	2	50	191	147	67	43	90	125	125	180
65	2½	65	199	155	75	46	104	145	145	180
80	3	80	217	173	91	46	124	160	160	180
100	4	100	227	183	101	52	146	180	180	180
125	5	125	265	211	127	56	176	210	220	230
150	6	150	277	223	139	56	206	240	250	230
200	8	197	295	248	169	60	257	295	—	350

Disc and seat material coding. Please refer to page 1.

Lugged Type ASME 150/200/250 psi Design - Gear Operated

- G-150DJL
- G-200DJL
- G-250DJL

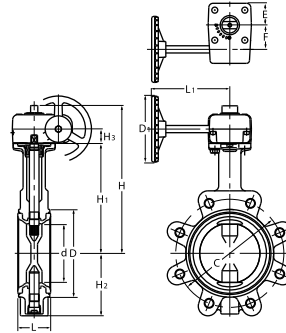
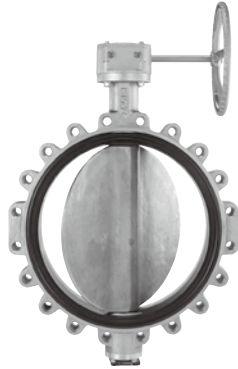

Dimensions

unit : mm

Size		d	H	H1	H2	H3	L	D	C	D1	L1	E	F
mm	inch												
50	2	50	194	147	67	19	43	90	120.5	80	122	29	28
65	2½	65	202	155	75	19	46	104	139.5	80	122	29	28
80	3	80	236	173	91	24	46	124	152.5	110	135	36	40
100	4	100	246	183	104	24	52	146	190.5	110	135	36	40
125	5	125	274	211	127	24	56	176	216	110	150	36	40
150	6	150	286	223	139	24	56	206	241.5	110	150	36	40
200	8	197	325	248	169	32	60	257	289.5	170	180	51	63
250	10	246	381	304	219	32	68	312	362	170	180	51	63
300	12	295	406	329	244	32	78	364	432	170	180	51	63
350	14	334	447	360	309	47	78	407	476.5	310	220	54	66
400	16	385	502	415	341	47	102	466	539.5	310	220	54	66
450	18	434	526	439	365	47	114	522	578	310	220	54	66
500	20	482	587	488	414	60	127	575	635	500	360	68	89
600	24	579	635	536	463	60	154	680	749.5	500	360	68	89

□ Disc and seat material coding. Please refer to page 1.

Lugged Type EN PN16/PN25 Design - Gear Operated

- G-PN16DJL
- G-PN25DJL

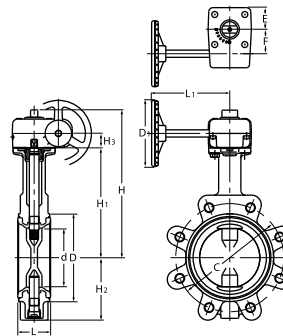
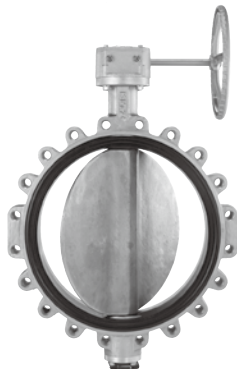

Dimensions

unit : mm

Size		d	H	H1	H2	H3	L	D	C		D1	L1	E	F
mm	inch								PN16	PN25				
50	2	50	194	147	67	19	43	90	125	125	80	122	29	28
65	2½	65	202	155	75	19	46	104	145	145	80	122	29	28
80	3	80	236	173	91	24	46	124	160	160	110	135	36	40
100	4	100	246	183	101	24	52	146	180	190	110	135	36	40
125	5	125	274	211	127	24	56	176	210	220	110	150	36	40
150	6	150	286	223	139	24	56	206	240	250	110	150	36	40
200	8	197	325	248	169	32	60	257	295	310	170	180	51	63
250	10	246	381	304	219	32	68	312	355	370	250	250	51	63
300	12	295	406	329	244	32	78	364	410	430	250	250	51	63
350	14	333	461	360	309	60	78	407	470	—	360	350	68	89
400	16	385	516	415	348	60	102	466	525	—	360	350	68	89
450	18	434	540	439	372	60	114	522	585	—	360	350	68	89
500	20	482	623	488	423	65	127	575	650	—	500	400	90	134
600	24	579	671	536	472	65	154	680	770	—	500	400	90	134

□ Disc and seat material coding. Please refer to page 1.

Double-eccentric kinematics, and all stainless steel bodies and trims guarantee high performance corrosion resistant service for application of KITZ Type UB butterfly valves to chemical industries.

Specification

Maximum service pressure			
10UB 16UB (size 2" to 12")	1.4MPa 2.0MPa	16UB (size 14" to 24") 150UB	1.4 MPa 1.9 MPa
Service temperature range			
PTFE seat Carbon filled PTFE seat	-29°C to +160°C -29°C to +200°C		
Wall thickness			
ASME B 16.34 Class 150			
Face to face dimensions			
6" and smaller 8" and larger	ISO 5752 Short ISO 5752 Medium		
Coupling flanges			
10UB 16UB 150UB	JIS 10K JIS 16K ASME Class 150		

Standard Materials

Parts	ASTM Materials	JIS Materials
Body	A351 GR.CF8*1	SCS13A*1
Stem	SUS304 N2	SUS304 N2
Disc	A351 GR.CF8*1	SCS13A*1
Gland	A351 GR.CF8*1	SCS13A*1
Seat ring	PTFE*2	PTFE*2
Seat retainer	A276 TYPE304	SUS304
Gland packing	PTFE	PTFE
Gasket	PTFE	PTFE

Feature

Double-eccentric Kinematics

The valves stem is designed eccentric to both the center of the seat ring (by X) and the center of the valve body (by Y), which makes the clearance C between the seat ring and the disc seating surface is spherically machined and contacts PTFE seat tightly through 360°C for leak-free service. All these help minimize frictional wear of seat rings and reduce the valve operating torque considerably.

Durable Seat Rings

Seat rings are made of PTFE with stainless steel supporter. Furthermore, double-eccentric kinematics relieve seat ring from damage or wear which is a rather usual problem of conventional butterfly valves, This makes the service life twice as long as rubber seated butterfly valves.

Retightening of Gland Packing

There is a room between the gland and the lever or gear to allow retightening of gland boltings without trouble of disassembly of the lever or gear during plant operation. Another feature of KITZ Type UB butterfly valves (Fig.2).

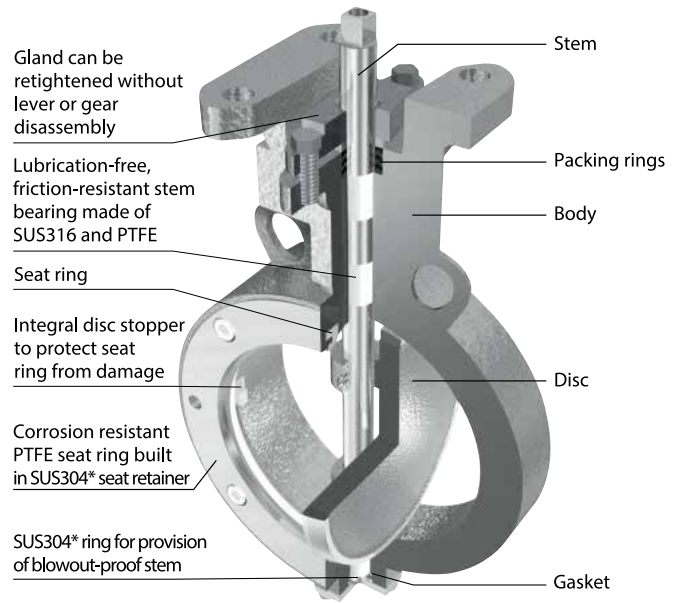

*SCS14A or SUS316 is available as an option

Parts	ASTM Materials	JIS Materials
Set bolt	A193 GR.B8	SUS304
Taper pin	A276 TYPE316	SUS316
Stem bearing	METAL BACKED PTFE	METAL BACKED PTFE
Gland bolts	A193 GR.B8	SUS304
Thrust washer	PTFE	PTFE
End plate	A351 GR.CF8	SCS13A
End plate bolts	A193 GR.B8	SUS304

*1. CF8M(316)/SCS14A(SUS316) is available as an option.
*2. carbon filled PTFE seat rings are optionally available.

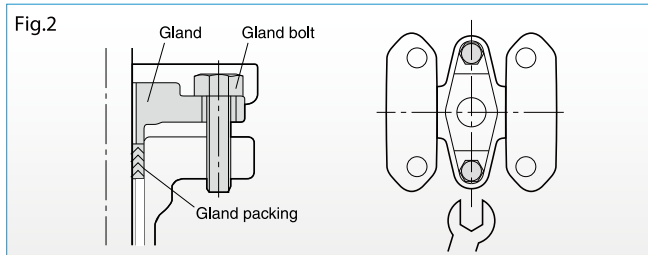
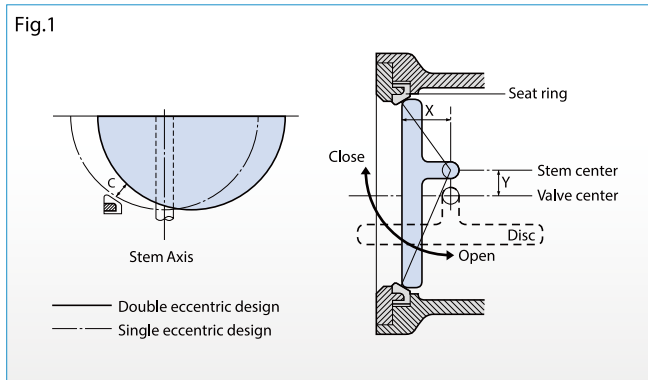

Flow Coefficient (Cv)

Size		Valve opening			
DN	NPS	30°	45°	60°	90°
50	2	17	33	54	83
65	2½	36	69	112	175
80	3	52	101	164	255
100	4	94	182	295	460
125	5	147	285	462	722
150	6	240	465	756	1180
200	8	455	883	1440	2240
250	10	743	1450	2350	3660
300	12	1150	2230	3610	5640
350	14	1440	2790	4520	7060
400	16	1910	3700	6010	9390
450	18	2500	4850	7880	12300
500	20	3110	6030	9800	15300
600	24	4650	9030	14700	22900

CAUTION

For mounting Valves onto pipes, be sure to use gaskets* specified below:

*Asbestos joint sheet or PTFE sheet

Size NPS	I / D		O / D		Thickness mm
	Min.	Max.	Min.	Min.	
2	60	61	90	3	
2½	73	77	115	3	
3	88	90	126	3	
4	108	116	146	3	
5	136	143	181	3	
6	162	170	211	3	
8	213	220	257	3	
10	266	275	322	3	
12	312	326	367	3	
14	342	359	410	3	
16	389	410	470	3	
18	444	460	530	3	
20	493	513	580	3	
24	594	615	688	3	

P-T rating of Seats

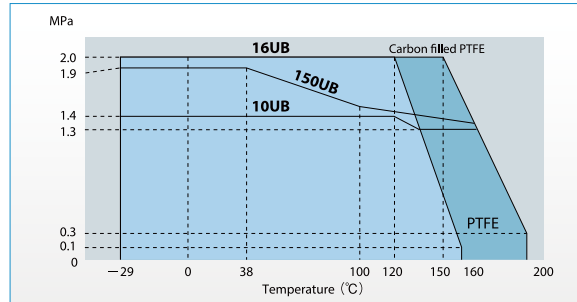

Contact KITZ for technical advice when service conditions may exceed the P-T rating range limited here.

Pressure Loss (for handling static clean water)

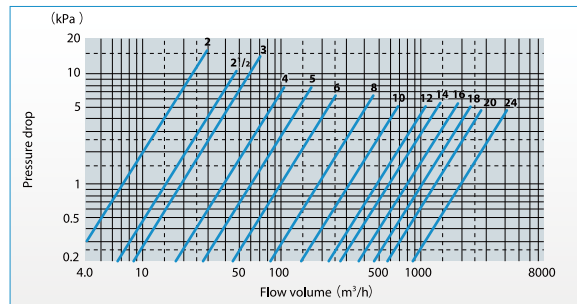

Flow Characteristics

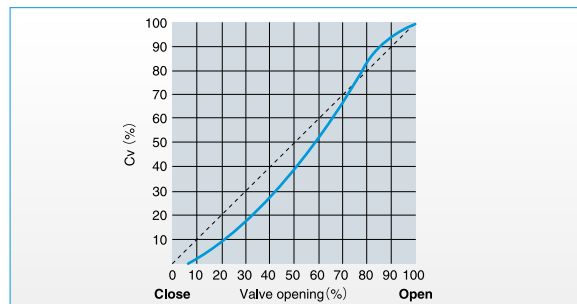

CAUTION

- The following gaskets should be used for installation of the UB series butterfly valves to pipelines.
 - [Type of Gasket]
 - Non-asbestos joint sheet gasket
 - Reinforced PTFE gasket (Jacketed gasket, Spiral Wound gasket, or Metal gasket cannot be installed.)
 - [Shape of Gasket]
 - Full-face gasket
 - Ring gasket (for full-face flanges and flat-face flanges)
 - [Dimension of Gasket]
 - The dimension of the gasket should comply with JIS B 2404 and ASME B 16.21 (minimum gasket thickness is 3 mm).
- UB series butterfly valves cannot be used with lapped loose flanges (lap joints + stub ends, stainless steel pipe joints with flanged pipe end).
- UB series butterfly valves may not be used with some large flat face flanges.
 - JIS 5K RF Flange: Not applicable
 - JIS 10K RF Flange: Applicable, but be sure to align the centers of the flange and the valve.
 - JIS 16K RF Flange: Applicable
 - Class 150 RF Flange: Applicable, but be sure to align the centers of the flange and the valve.
- UB series butterfly valves cannot be used with rubber lining pipes
- UB is a unidirectional valve. The valve must be installed according to an arrow, provided on the side of the operator mounting flange. The arrow must point from the higher pressure side to the lower pressure side in the valve closed position.

Lever Operated

10UB
150UB

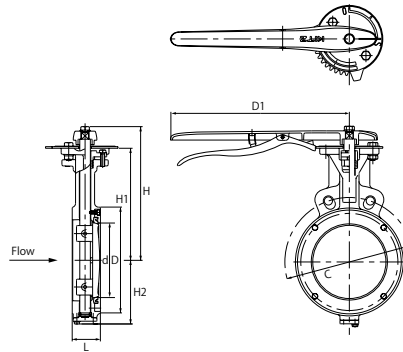

Dimensions

unit : mm

Size		d	H	H1	H2	L	D	C		D1
mm	inch							10UB	150UB	
50	2	50	176	138	64	43	90	120	120.5	230
65	2½	65	186	148	74	46	115	140	139.5	230
80	3	78	208	167	82	46	126	150	152.5	280
100	4	98	222	181	92	52	146	175	190.5	280
125	5	123	241	202	115	56	181	210	216.5	350
150	6	148	264	225	126	56	211	240	241.5	350

Gear Operated

GL-10UB
GL-16UB
GL-150UB

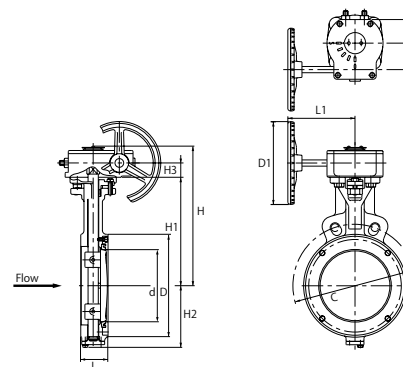

Dimensions

unit : mm

Size		d	H	H1	H2	H3	L	L1	D	D1	E	F	C			Gear type
mm	inch												10UB	16UB	150UB	
50	2	50	191	138	64	25	43	150	90	140	35	42	120	120	120.5	No. 1
65	2½	65	201	148	74	25	46	150	115	140	35	42	140	140	139.5	No. 1
80	3	78	225	167	82	28	46	195	126	170	42	60	150	160	152.5	No. 2
100	4	98	239	181	92	28	52	195	146	170	42	60	175	185	190.5	No. 2
125	5	123	260	202	115	28	56	204	181	200	42	60	210	225	216.5	No. 2
150	6	148	283	225	126	28	56	204	211	200	42	60	240	260	241.5	No. 2
200	8	197	350	263	164	47	71	280	257	310	54	68	290	305	298.5	No. 3
250	10	243	417	315	235	60	76	310	322	360	69	89	355	380	—	No. 4
300	12	295	444	342	258	60	83	310	367	360	69	89	400	430	—	No. 4
350	14	325	476	374	294	60	92	363	410	500	70	93.5	445	480	—	No. 5
400	16	371	572	408	315	95	102	377	470	500	90	134	510	540	—	No. 6
450	18	421	606	442	370	95	114	377	530	500	90	134	565	605	—	No. 6
500	20	470	622	458	398	95	127	377	580	500	90	134	620	660	—	No. 6
600	24	569	758	558	475	170	154	377	688	500	105	213	730	770	—	No. 7

THROTTROL is designed to handle extremely low fluid volume, while it completely shuts off the line flow.

Specification

- Maximum service pressure ······ 1.0MPa
- Service temperature range EPDM ··· ·· -20°C to +120°C
Note: Refer to Pressure-Temperature Ratings in next page.
- Rangeability ··················· 160 : 1
- Flow characteristics ············· Equal percentage flow characteristics
- Sealing feature ················· Tight shutoff
- Face to face dimensions ········· JIS B 2032 series number 46
- Coupling flange ················· JIS 5K/10K

Feature

Excellent flow volume control performance with 160:1 of rangeability

- Tight shut/high rangeability is realized by combining disc section for full-shutoff and disc section for low-opening control for the disc. Also, cavitation is suppressed by installing a pressure chamber to improve anti-noise multi-orifice.
- Installing a multi hall at the disc section for low-opening control and the fin section realizes flow volume characteristics close to ideal equal percent characteristics for flow volume control.

The pressure reducer slit and multi-orifices reduce flow velocity, and minimize cavitation and noise.

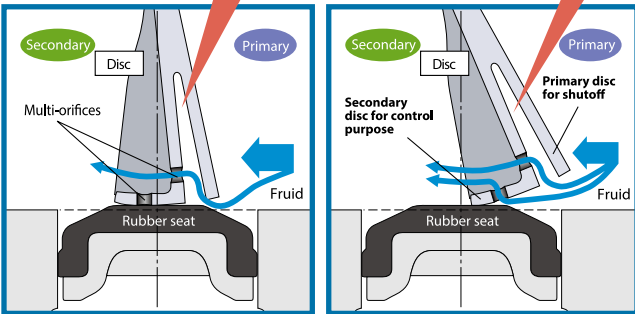

At low degree of opening: 1

At low degree of opening: 2

Prevention of erosion by jet flow

- The vulcanized bond seat is suitable for controlling high flow velocity fluid to reduce erosion due to jet flow.

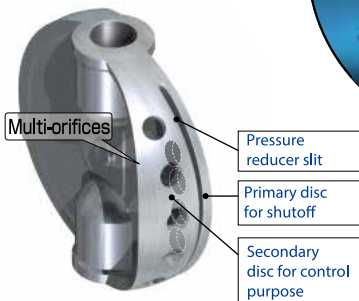
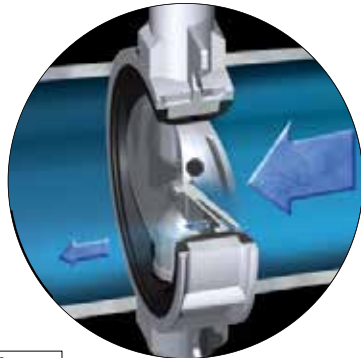

Fluids only flow through the orifices at low degree of opening.

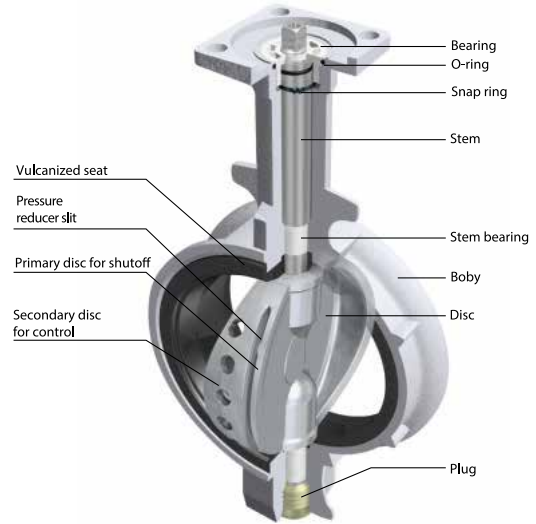

Standard Materials

*Please refer to the drawing of deliverables for detail.

Parts	Material
Body	FCD450-10
Stem	SUS403 (50 [^] to 100 [^]) SUS420J2 (125 [^] to 200 [^]) SUS630 (250 [^] to 200 [^])
Disc	SCS13A
Seat	EPDM
O-ring	EPDM (50 [^] to 200 [^])
Bearing	POM (50 [^] to 200 [^])
Plug	Chromated ZDC2
Bottom stem	SUS403 (50 [^] to 100 [^]) SUS420J2 (250 [^] to 300 [^])

Flow Characteristic Curve

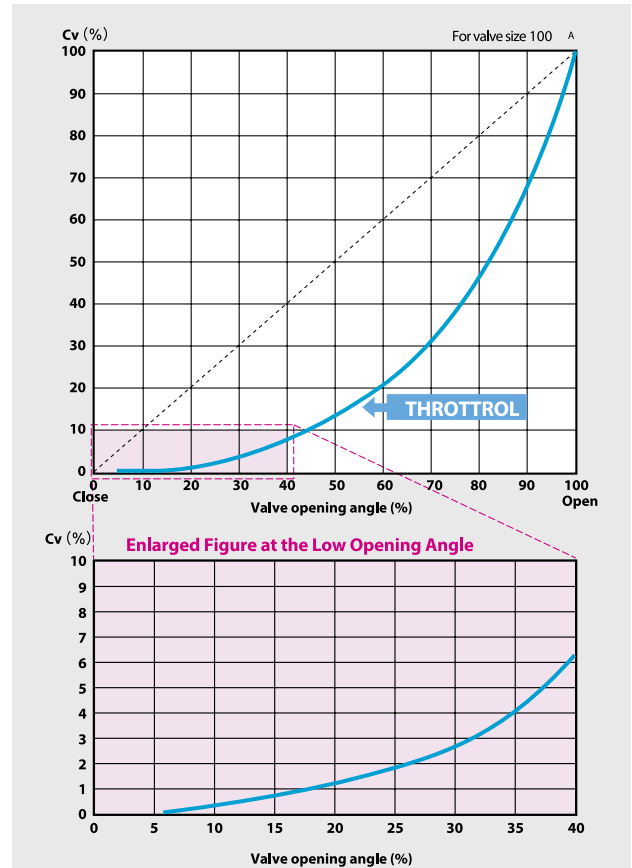

Cv

Nominal size		Valve opening angle (%)										
A	B	5	10	20	30	40	50	60	70	80	90	100
50	2	0.2	0.7	1.8	4.0	7.5	14.3	23.9	35.9	49.3	62.6	74.2
65	2½	0.3	1.0	2.0	4.6	10.0	24.6	44.0	68.9	99.2	132.8	167.0
80	3	0.3	1.6	4.5	10.0	25.3	47.0	71.9	106.4	149.5	201.9	258.5
100	4	0.4	1.9	6.0	13.3	29.4	55.3	94.2	149.6	225.4	325.6	454.2
125	5	0.5	4.3	9.8	29.0	75.0	128.2	208.2	308.9	429.2	566.4	713.9
150	6	2.5	12.0	29.0	77.0	141.2	209.8	289.5	390.2	528.3	726.8	1015.7
200	8	5.3	18.8	45.9	138.2	244.5	382.5	553.7	827.7	1175.3	1618.6	1986.6

P-T Rating of Seats

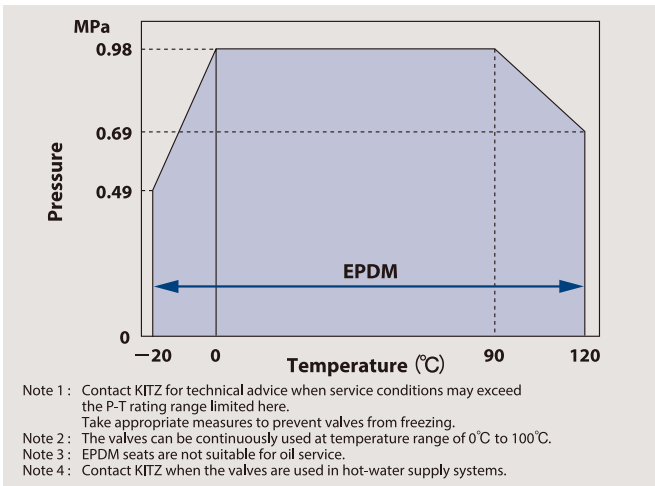

Cavitation Coefficient

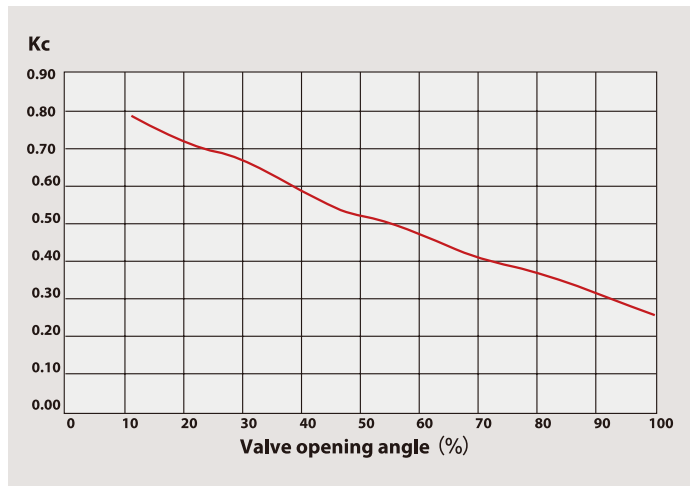

CAUTION

- THROTTROL is a unidirectional valve. THROTTROL must be installed with the direction of flow according to the arrow marked on the body at the time of piping.
- THROTTROL cannot be used with rubber lining pipes. THROTTROL is constructed to seal the flange by pressing a rubber sheet with the compressive force exerted by the flange, where the compressive force becomes too large or too small if the rubber lining is applied to the flange joint surface, thereby causing an increase in the operating torque of the valve, deterioration of the sealing member, or external leakage.

High Rangeability Butterfly Valves

HRDJ

Locking Mechanism Gears Operated with Locking Mechanism

G-10HRDJUE
G-20HRDJUE

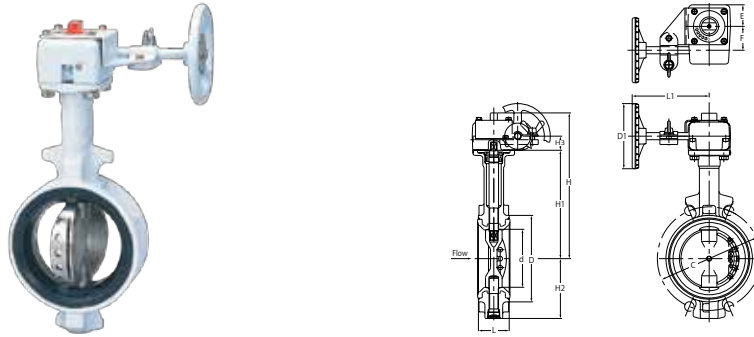

Dimensions

unit : mm

Size		d	H	H1	H2	H3	L	D	C		Gear unit				
mm	inch								10K	20K	D1	L1	E	F	Size
50	2	50	210	147	67	24	43	90	105	120	110	135	36	40	No. 1
65	2½	65	218	155	75	24	46	104	130	140	110	135	36	40	No. 1
80	3	80	236	173	91	24	46	124	145	150	110	135	36	40	No. 1
100	4	100	246	183	101	24	52	146	165	175	110	135	36	40	No. 1
125	5	125	274	211	127	24	56	176	200	210	110	150	36	40	No. 1
150	6	150	286	223	139	24	56	206	230	240	110	150	36	40	No. 1
200	8	196	325	248	169	32	60	257	280	290	170	180	51	63	No. 2
250	10	245	393	304	220	47	68	312	355	355	310	280	54	66	No. 3
300	12	295	418	329	244	47	78	364	400	410	310	280	54	66	No. 3

Proportional Control Electrically Operated

EXCN-10HRDJUE
EXCN-20HRDJUE
EXD-10HRDJUE
EXD-20HRDJUE

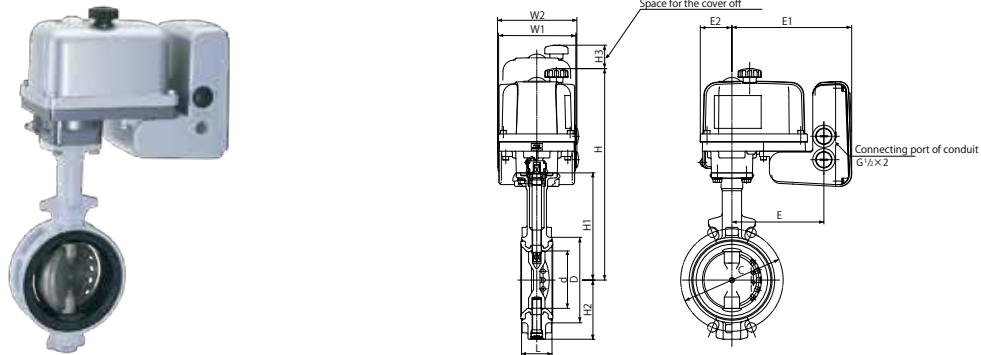

Dimensions

unit : mm

Size		d	H	H1	H2	L	D	C		Actuator						Actuator size
mm	inch							10K	20K	W1	W2	E	E1	E2	H3	
50	2	50	328	147	67	43	90	105	120	131	132	157	206.5	54	107.5	Size 2
65	2½	65	336	155	75	46	104	130	140	131	132	157	206.5	54	107.5	Size 2
80	3	80	354	173	91	46	124	145	150	131	132	157	206.5	54	107.5	Size 2
100	4	100	389.5	183	101	52	146	165	175	158	132	180.5	230	69	117.5	Size 3
125	5	125	417.5	211	127	56	176	200	210	158	132	180.5	230	69	117.5	Size 3
150	6	150	429.5	223	139	56	206	230	240	158	132	180.5	230	69	117.5	Size 3
200	8	197	524	248	169	60	257	280	290	188	132	196	245.5	73	153	Size 4
250	10	247	580	304	219	68	312	345	355	188	132	196	245.5	73	153	Size 4
300	12	295	686	329	244	78	364	400	430	188	132	196	245.5	73	153	Size 5

Power sources of aduator coding. Please refer to page 1.

Suitable for high temperature service

Specification

- Maximum service pressure ······ 0.5MPa
- Service temperature range ······ 0°C to +230°C
- Maximum allowable leakage ······ 3% of normal Cv values (D type)
2% of normal Cv values (A type)
- Coupling flange ············ JIS 5K/10K

Feature

Type D

For high temperature

The Type D damper enables flow volume control of high temperature fluid up to 230 Degree-C by a metal disc and metal seat (hard chrome coating).

Type A

For high temperature fluid

Angle bar of the type A damper is shaped in oval to have the disc contact with inner surface of the body with some angle when it is closed. Therefore, it can be used for the same application of the type D damper with even less leakage volume than the type D.

Flow Coefficient (Cv)

Size		Cv
mm	inch	
50	2	104
65	2 1/2	174
80	3	348
100	4	557
125	5	905
150	6	1183
200	8	2575
250	10	4037
300	12	6264



Standard Materials

Parts	Material
Body	FC250+HCr
Stem	SUS403
Disc	SUS430
Gland	C3604BE
Gland packing	Asbestos-free
Dics nut	SUS304
Disc bolt	SUS304
Index plate	SPCC
Set bolt	SS400
Bottom stem	SUS403

*Please refer to the drawing of deliverables for detail.
A gasket is required for piping this product.

Flow Characteristics

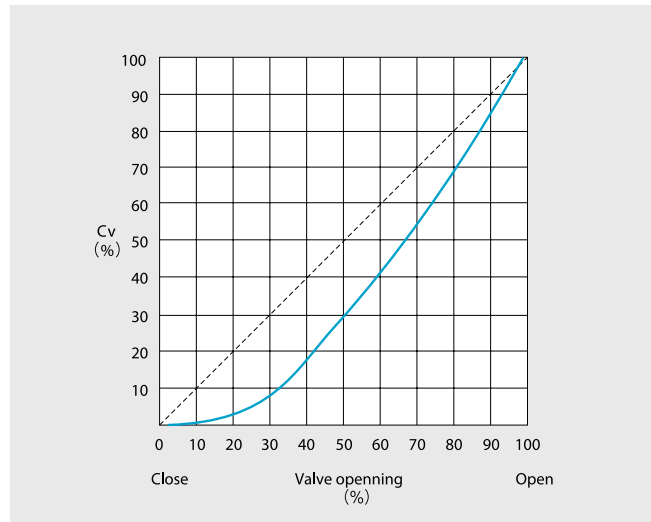

Type D Lever Operated

10D

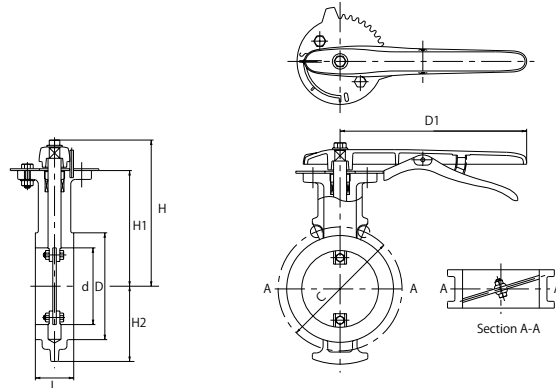

Dimensions unit : mm

Size		d	H	H1	H2	L	D	C	D1
mm	inch								
50	2	50	183	145	57	40	90	120	200
65	2½	65	191	153	75	45	115	140	200
80	3	80	198	160	82	50	126	150	200
100	4	100	208	170	98	60	146	175	200
125	5	130	237	196	117	65	181	210	280
150	6	150	247	206	145	70	211	240	280
200	8	200	272	231	170	80	257	290	280
250	10	250	340	297	205	90	322	355	350
300	12	300	365	322	230	100	367	400	350

Type D Gear Operated

GL-10D

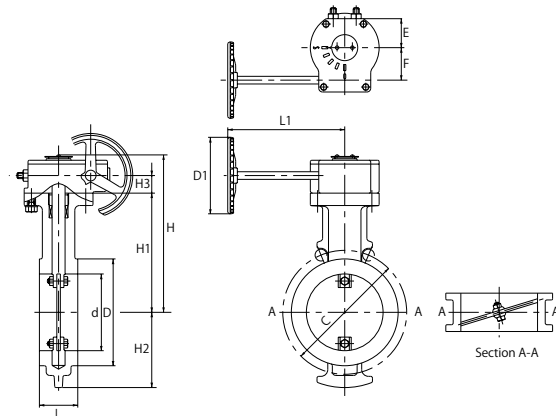

Dimensions unit : mm

Size		d	H	H1	H2	L	D	C	H3	D1	L1	E	F	Gear type
mm	inch													
50	2	50	198	145	57	40	90	120	25	110	150	35	42.5	No. 1
65	2½	65	206	153	75	45	115	140	25	110	150	35	42.5	No. 1
80	3	80	213	160	82	50	126	150	25	110	150	35	42.5	No. 1
100	4	100	223	170	98	60	146	175	25	110	150	35	42.5	No. 1
125	5	130	249	196	117	65	181	210	25	170	190	35	42.5	No. 1
150	6	150	259	206	145	70	211	240	25	170	190	35	42.5	No. 1
200	8	200	284	231	170	80	257	290	25	170	190	35	42.5	No. 1
250	10	250	355	197	205	90	322	355	28	170	195	42	66.5	No. 2
300	12	300	380	322	230	100	367	400	28	170	195	42	66.5	No. 2

Type A

Lever Operated

10A

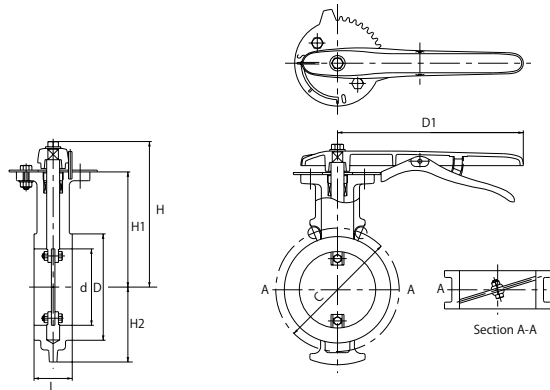

Dimensions

unit : mm

Size		d	H	H1	H2	L	D	C	D1
mm	inch								
50	2	50	183	145	57	40	90	120	200
65	2½	65	191	153	75	45	115	140	200
80	3	80	198	160	82	50	126	150	200
100	4	100	208	170	98	60	146	175	200
125	5	130	237	196	117	65	181	210	280
150	6	150	247	206	145	70	211	240	280
200	8	200	272	231	170	80	257	290	280
250	10	250	340	297	205	90	322	355	350
300	12	300	365	322	230	100	367	400	350

Type A

Gear Operated

GL-10A

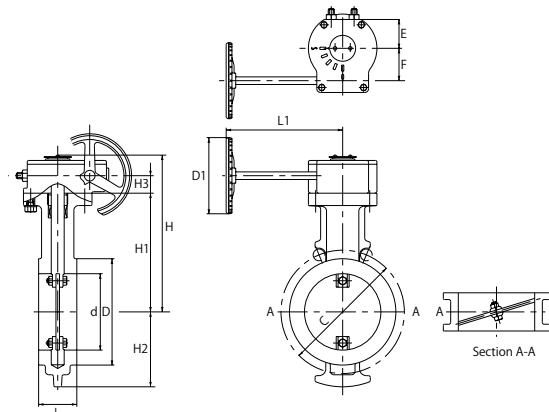

Dimensions

unit : mm

Size		d	H	H1	H2	L	D	C	H3	D1	L1	E	F	Gear type
mm	inch													
50	2	50	198	145	57	40	90	120	25	110	150	35	42.5	No. 1
65	2½	65	206	153	75	45	115	140	25	110	150	35	42.5	No. 1
80	3	80	213	160	82	50	126	150	25	110	150	35	42.5	No. 1
100	4	100	223	170	98	60	146	175	25	110	150	35	42.5	No. 1
125	5	130	249	196	117	65	181	210	25	170	190	35	42.5	No. 1
150	6	150	259	206	145	70	211	240	25	170	190	35	42.5	No. 1
200	8	200	284	231	170	80	257	290	25	170	190	35	42.5	No. 1
250	10	250	355	197	205	90	322	355	28	170	195	42	60	No. 3
300	12	300	380	322	230	100	367	400	28	170	195	42	60	No. 3

Compact butterfly valves for threaded piping connection



Specification

- Size 1/2^B~2^B
- Product code FV ·UV
- Connection type Threaded type (JIS B 0203)
- Maximum pressure 1.21MPa
- Service temperature range 0°C to +70°C
- Face to face dimensions Standard of KITZ

Feature

Clean design with pocket-less to prevent standing fluid

- Full-port structure prevents standing fluid in pocket used in a ball valve, and rubber seat is adopted to clear the Food Sanitation Act.

Threaded type which is the first in butterfly valve

- Screw-in type for simple pipe connection enables adoption to various small sizes of piping line used in vast range of application.

Compact/light weight design

- Compact design with weight of approximately 1/4, dimension between faces of approx. 2/3 and height of valve of approx. 3/4 compared to the same size ball valves. (Compared to our products)

W-NBR seat with high sealing characteristics

- Adopting W-NBR with high elasticity for a seat to improve sealing characteristics to be ideal for fluid line such as air/gas for which high sealing is required.

Self cleaning feature for sealing section

- Self cleaning feature to remove dirt at sealing section during open/close with elastic effect of the disc is equipped.

Capable of flow volume control

- It is equipped with the balancing stop mechanism to fix at intermediate opening degree, and is capable of stable flow volume control thanks to opening scale.

Accurate lost-wax casting

- Body of the stainless steel product employs accurate lost-wax casting to configure clean and dust-free piping line with smooth surface.

Flow Rate

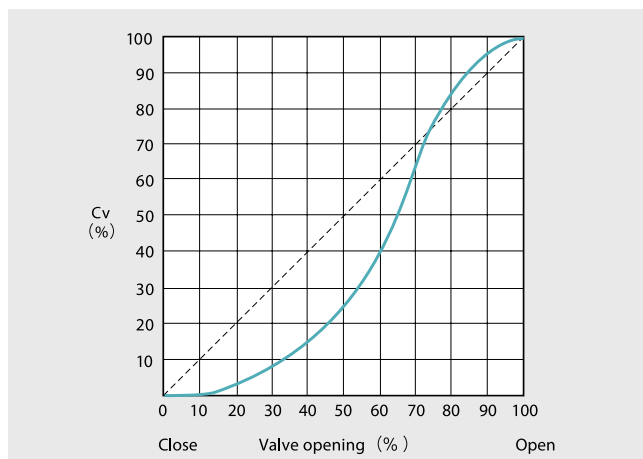

Standard Materials

Parts	Material	
	FV	UV
Body	C3771BE	SCS13A
Stem	SUS304	
Disc	SUS304+W-NBR	
Brace of Packing	C3771BD	SUS304
O-ring	NBR	

*Please refer to the drawing of deliverables for detail.

W-NBR(No.NF81W) Test Result

Test item		Test result	Criteria
Material test	Lead	Applicable (7.00ppm)	100ppm or less
	Cadmium	Applicable (not detected [0.2ppm or less])	100ppm or less
Dissolution test	Potassium permanganate consumption	Applicable (2.4ppm)	10ppm or less
	Heavy metal	Applicable	Must be thinner than the color presented by standard fluid for comparison
Vaporization residue	Water	Applicable (0ppm)	30ppm or less
	4% acetic acid	Applicable (1.5ppm)	30ppm or less
	n-heptane	Applicable (16.5ppm)	30ppm or less
	20% ethanol	Applicable (1.5ppm)	30ppm or less

Cv

Size		Cv
A	B	
15	1/2	8.7
20	3/4	21
25	1	39
32	1 1/4	66
40	1 1/2	94
50	2	176

CAUTION

This product is not applicable for combustible gas or toxic gas.

Pressure Loss

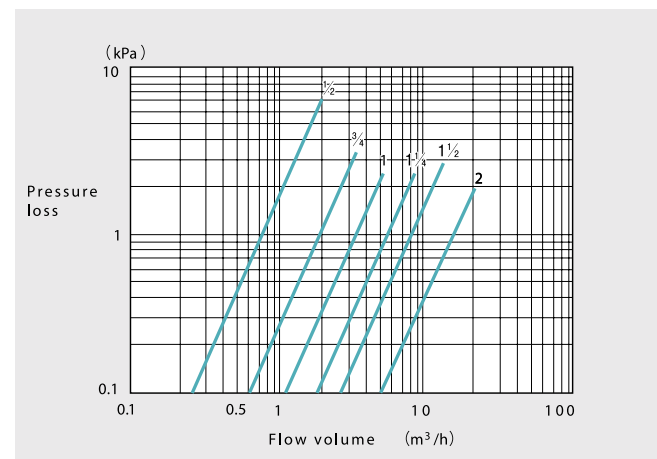

Brass Type

Lever Operated

FV

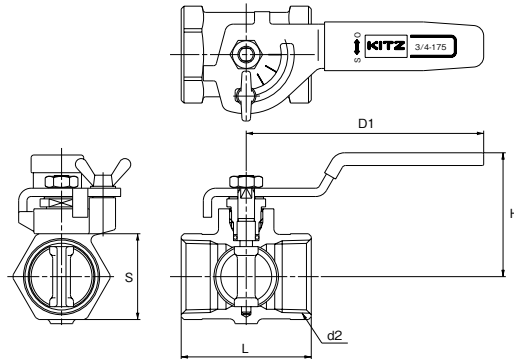

Dimensions

unit : mm

Size		d2	H	D1	L	S
mm	inch					
15	1/2	Rc 1/2	45	85	47	28
20	3/4	Rc 3/4	47	85	51	24
25	1	Rc 1	50	85	58	41
32	1 1/4	Rc 1 1/4	60	110	67	50
40	1 1/2	Rc 1 1/2	64	110	73	56
50	2	Rc 2	70	110	82	68

Stainless Type

Lever Operated

UV

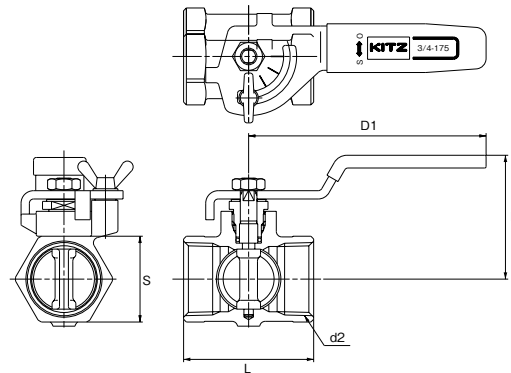

Dimensions

unit : mm

Size		d2	H	D1	L	S
mm	inch					
15	1/2	Rc 1/2	45	85	43	25
20	3/4	Rc 3/4	47	85	47	31
25	1	Rc 1	50	85	56	38
32	1 1/4	Rc 1 1/4	60	110	63	47
40	1 1/2	Rc 1 1/2	64	110	69	54
50	2	Rc 2	70	110	77	67

Precautions for Trouble-free Operation of KITZ Butterfly Valves

Valve Selection

- 1 Make sure to select a valve with design specifications that are appropriate for the fluid type and the pressure and temperature conditions expected.
- 2 Lubricants are applied to discs and rubber seats to protect their surfaces.
Oil-free treated types are also available. Contact the KITZ Corporation or one of its local distributors for the details.
- 3 Contact the KITZ Corporation or one of its local distributors for service with fine particles.

Storage and Handling

- 1 Valves must be stored in a clean, dry, corrosion-free environment with no direct exposure to the sunlight. Valves should be left open 10° to prevent permanent distortion of the resilient seats. Refrain from overloading valves and their actuators by storing them in piles or placing other objects on them.

Mounting on Pipelines

- 1 Valves must be mounted on flanges only after flanges have been welded to pipes and cooled down to the ambient temperature. Otherwise, the welding heat may affect the quality of the resilient seats.
- 2 Edges of welded flanges must be machined to achieve a smooth surface finish so that they will not damage the resilient seats during valve mounting. Flange faces must be free from damage or deformation and must be cleaned to remove rust and any foreign objects to prevent leakage through the valve and flange connections. Gaskets are not required for mounting KITZ XJ series butterfly valves.
- 3 Flanges and pipe bores must be cleaned thoroughly to remove welding spatters, scales, and foreign objects that may have been left inside.
- 4 Accurate centering of each pair of upstream and downstream pipes is essential for trouble-free operation of the valves mounted between them. Incorrect centering, shown in **Fig.1**, must be avoided at all costs.

Fig.1

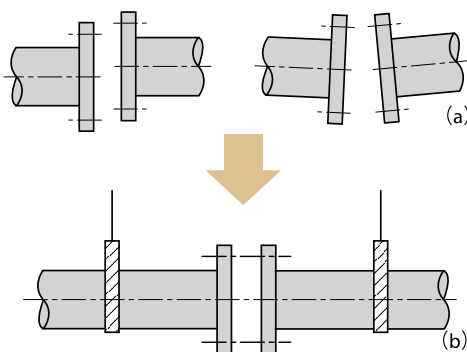

- 5 When mounting valves, set jack bolts under the pipes to provide support at a consistent height and adjust the flange-to-flange distance to allow 6 to 10 mm of space on each side of the valve body. Remember that valves must be left open 10° from the fully closed position (**Fig.2**).
- 6 Set two bolts into the lower mounting guides of a valve and mount it carefully so that the flange faces do not damage the resilient seats.
- 7 Then set another two bolts into the upper mounting guides of the valve, ensuring the correct centering between the pipes and the valve.
- 8 Try opening the valve to check that there is no obstructing contact between the valve disc and the flanges.
- 9 Remove the jack bolts, set all bolts around the valve body, and tighten the bolts alternately and diagonally until the flanges come into contact with the valve body (**Fig.3**). Refer to the table shown below for recommended torque values.

Fig.2

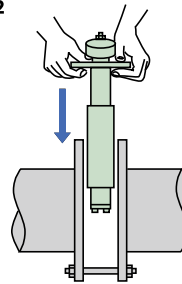

Recommended torque values

DN	N · m (kgf · m)
40	49 (5)
50	
65	
80	
100	
125	88 (9)
150	
200	
250	118 (12)
300	

Fig.3

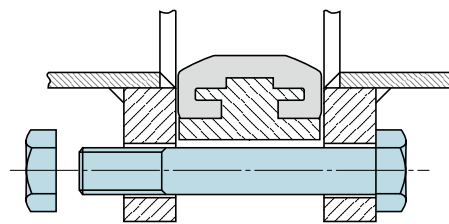

- 10 For mounting actuated valves, provide valve supports to prevent bending of valve necks and reduce valve and pipe vibration.
- 11 Do not step on valve necks or valve hand-wheels.
- 12 Do not mount butterfly valves directly to check valves or pumps; this may result in damage caused by the disc contacts.
- 13 Do not mount valves on the downstream sides of elbows, reducers, or regulating valves where the fluid velocity changes. It is recommended that valves be installed at distances of approximately 10 times the nominal valve sizes in such cases.

- 14 Mount valves taking into consideration the effects on discs of fluid velocity or pressure changes in the piping. Refer to the illustrations. (Fig.4)
Contact the KITZ Corporation or one of its local distributors for the details.

Fig.4

● Mounting to bent pipe

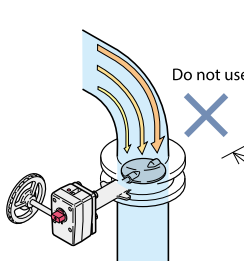
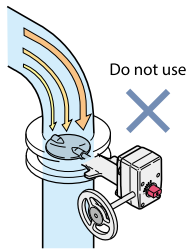
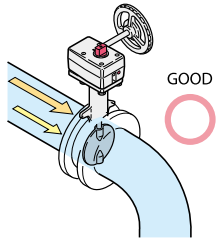

● Mounting to pump outlet

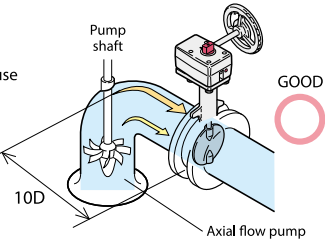
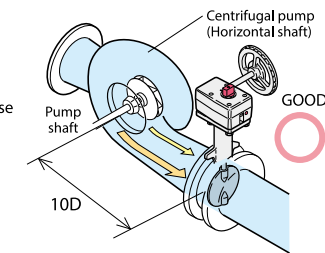
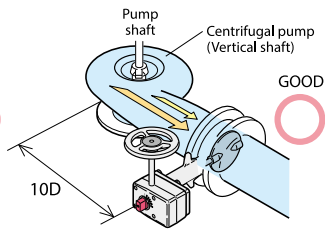

Note:
Centering with centering sleeves is required for valves equipped with such sleeves for accurate centering (Fig.5)
Refer to page 3 for applicable sizes.

Fig.5

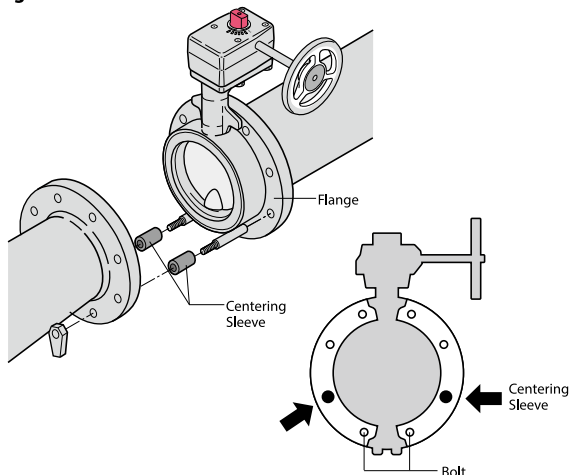

Valve Operation

- 1 Valves equipped with manual operators such as levers, handles and gears, must be MANUALLY OPERATED ONLY. Application of excessive external force to operate valves may result in malfunction of valves and their operators.
- 2 Make sure to open valves fully before conducting a loop test of the piping system at a line pressure higher than the nominal pressure of the tested valves. Never use closed valves in place of blind flanges.
- 3 When valves need to be removed from pipes for maintenance or any other reason, make sure to thoroughly relieve the line pressure beforehand. Loosening piping bolts under line pressure is dangerous. Any residual fluid left inside the pipeline must be completely drained.
- 4 Users should contact the KITZ Corporation or one of its local distributors for technical advice when valves need to be continuously pressurized while left open 30° or less.
- 5 Do not use position indicators to operate valves or overload position indicators. These actions may cause damage to the indicators.
- 6 Make sure to use blind flanges when butterfly valves are mounted at the end of pipelines.
- 7 Standard actuators are referenced in this catalog for actuated valve operation. Contact the KITZ Corporation or one of its local distributors for information on mounting optional actuators.
- 8 Contact the KITZ Corporation for service at hopper or pump outlets.
- 9 Avoid touching gear operators and actuator stopper bolts accidentally.
- 10 Periodic inspection is recommended to
 - Check the valve opening degree
 - Check loosened bolts and leakage at each connection
 - Check vibration and noise
- 11 Refer to instruction manual for other precautions. Refer to actuator catalogs and instruction manuals for actuated valves.

! WARNING

To prevent stem blow-out, do not disassemble necks while a valve is pressurized. Do not dismantle valve operating devices because this may cause valve discs to rotate and may result in valve malfunction.

WARNING

- This product is not designed for explosion-proof. DO NOT use it in any inflammable or corrosive gaseous environment. Also DO NOT use it for handling inflammable fluid.
- DO NOT disassemble the actuator while the unit is being energized.
- DO NOT put your fingers or insert any foreign objects within the valve core before or during valve operation.

CAUTION

- Make sure to read and follow instructions of operation manual when handling the actuator introduced in this catalog.
- Handle the product carefully so that it may not fall or drop on the ground. Any extraordinary mechanical impact should be avoided.
- Indoor storage of the product in a dust-free, low humidity and well-ventilated place is recommended.
- DO NOT remove protective cover until installation on piping.
- DO NOT apply excessive load or step on the product, which may damage the product or cause personal injury.
- Allow sufficient room for manual operation or removal of the actuator cover, when the valve is installed in the pipeline.
- Where the actuator is exposed to sunlight or rainwater while in service, use appropriate protection for trouble-free operation. Also use insulation boards for the heat generated from the equipment around the actuator.
- Take some appropriate measures, if the possibilities of damage by briny atmosphere, snow or freezing are expected.
- Avoid installing the valve where the actuator may be hampered by vibration caused by other equipment such as pumps or engines.
- Before installation, the connecting pipes should be cleaned to remove any foreign objects such as sand, dust or welding spatters.
- When threaded valves are screwed into pipes, apply a spanner to the ends of valves on the side of the connecting pipe being inserted.
- For flanged valves, alternately tighten bolts of the end flanges in a star pattern to ensure to fasten the flanges properly.
- The actuator should not be mounted downward in any piping orientation.
- The pipeline should be flushed to remove foreign particles from pipes.
- If cast iron or cast carbon steel valves are used in the water line, be aware that rust may develop in the valves, which may damage the ball seats, leading to operation failure. Pay extra attention on valve selection and protection from rust.
- Connect cables correctly in accordance with the circuit diagram.
- Ensure to use a terminal base when connecting cables.
- After connecting cables, conduct an insulation resistance test to ensure its insulation.
- Ensure the housing is securely sealed with such sealing materials as O-rings to prevent dust or water from entering the housing.
- DO NOT try to operate two or more actuators at the same time with only one operation switch. Other electrical equipment should not also be operated at the same time with one operation switch.
- Ensure the space heater to be activated all the time to keep the inside of the actuator warm for the prevention of due condensation, which may result in operational malfunction.
- Ensure the actuator is powered off, when it is used for manual operation.
- Place at least one-second interval, when the direction of operation is reversed. Failure to follow this instruction may result in operation malfunction.
- DO NOT make any unauthorized modifications. Such modifications may result in causing a troubled operation or accidents. We shall not be responsible for any troubles or accidents caused by improper use of the products.
- Refer to our catalogs for more details on valve information.

CAUTION

Technical data published in this catalog have been developed from our design calculation, in-house testing, field reports provided by our customers and/or published official standards or specifications. They are good only to cover typical applications as a general guideline to users of KITZ products introduced in this catalog.

For any specific application, users are kindly requested to contact the KITZ Corporation for technical advice, or to carry out their own study and evaluation for providing suitability of these products to such an application. Failure to follow this request could result in property damage and/or personal injury, for which we shall not be liable.

While this catalog has been compiled with the utmost care, we assume no responsibility for errors, impropriety or inadequacy. Any information provided in this catalog is subject to from-time-to-time change without notice for error rectification, product discontinuation, design modification, new product introduction or any other cause that the KITZ Corporation considers necessary. This edition cancels all previous issues.

CAUTION

Pressure-temperature ratings and other performance data published in this catalog have been developed from our design calculation, in-house testing, field reports provided by our customers and / or published official standards or specifications. These data apply only to typical applications and are provided as general guidelines to users of KITZ products introduced in this catalog.

For any specific application, users are kindly requested to contact the KITZ Corporation for technical advice, or to carry out their own study and evaluation to ensure the suitability of these products for such an application. Failure to follow this request could result in property damage and / or personal injury for which we shall not be liable.

While this catalog has been compiled with the utmost care, we assume no responsibility for errors, impropriety, or inadequacy. Any information provided in this catalog is subject to change without notice for error rectification, product discontinuation, design modification, new product introduction, or any other cause that the KITZ Corporation considers necessary. This edition cancels all previous issues.

Read instruction manual carefully before using KITZ products.

NOTICE

If any products designated as strategic material in the Foreign Exchange and Foreign Trade Law, Cabinet Order Concerning Control of Export Trade, Cabinet order Concerning Control of Foreign Exchange and other related laws and ordinances ("Foreign Exchange Laws") are exported to any foreign country or countries, an export license issued by the Japanese Government will be required under the Foreign Exchange Laws.

Furthermore, there may be cases in which an export license issued by the Government of the United States or the government of another country will be required under the applicable export-related laws and ordinances of that country.

The contract shall become effective subject to a relevant export license being obtained from the Japanese Government.

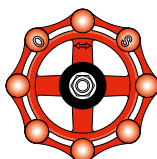

*A chrysanthemum-handle is a symbol of KITZ,
the brand of valve reliability*

ISO 9001 certified since 1989

KITZ
KITZ CORPORATION

1-10-1, Nakase, Mihama-ku, Chiba 261-8577, Japan
International Sales Dept.
Phone : 81-43-299-1730, 1732 and 1733
Fax : 81-43-299-0121

— Distributed by —

