

# DKXS 1,25

## Twin-Shaft Batch Mixer

### Customer Documentation

#### B-25537-100-01

TRANSFORMING  
MATERIALS  
INTO VALUE



BHS-Sonthofen GmbH  
An der Eisenschmelze 47  
D-87527 Sonthofen

[info@bhs-sonthofen.de](mailto:info@bhs-sonthofen.de)  
[www.bhs-sonthofen.de](http://www.bhs-sonthofen.de)

Picture similar

BHS-Sonthofen GmbH, An der Eisenschmelze 47, 87527 Sonthofen

MMB Technology Co., Ltd.

Moo 6, Saothonghin, 68/39  
11140 Bangyai district, Nonthaburi  
THAILAND

your ref.:

dated:

our ref.:

phone:

mobile:

fax:

e-mail:

date:

/Bai/

+86 22 82121187

+86 22 82107095

baiyanxia@bhs-sonthofen.cn

21.08.17

Project No. B-25537-100-01  
Machine type: DKXS1,25  
Client documentation: 902030245 - 600479052-001 - A

Dear Sirs,

We are pleased to send you enclosed our Client Documentation in English.

Sincerely yours,

BHS-Sonthofen GmbH



## Contact Address

# Client Documentation

**BHS-Sonthofen GmbH**  
**An der Eisenschmelze 47**  
**87527 Sonthofen, Germany**  
**Spare Parts: Tel. 0049 8321/6099 144 - 146**  
**Fax 0049 8321/6099 120**  
**E-mail: [info@bhs-sonthofen.de](mailto:info@bhs-sonthofen.de)**  
**Internet: [www.bhs-sonthofen.de](http://www.bhs-sonthofen.de)**



## Twin-Shaft Batch Mixer

Pos	QTY	Part #	ARTICLE SHORT DESCRIPTION 1	ARTICLE SHORT DESCRIPTION 2	DIM/TYPE	MATERIAL	STANDARD	WEIGHT
1	1	902001099	OPERATING INSTRUCTIONS					
2	1	902030246	TECHNICAL DOCUMENTS					
3	1	902030247	SPARE PARTS LIST					
			<b>END OF BOM!</b>					

	DKXS1,25	COVER PAGE	
	902030245		





## Cover Sheet

# Operating Instructions

1. <i>Information for User</i> .....	900359300
2. <i>General Safety Instructions</i> .....	900359400
3. <i>Delivery and Intermediate Storage</i> .....	900369400
4. <i>Machine Description</i> .....	900359700
5. <i>Erection and Electric Connection</i> .....	900359800
6. <i>Starting and Operation</i> .....	900359900
7. <i>Servicing and Inspection</i> .....	900360100
8. <i>Lubrication</i> .....	900401500
9. <i>Maintenance</i> .....	900360500



## Twin-Shaft Batch Mixer



## Information for User

# Operating Instructions

- 1. *Instruction to Owner and Operators* .....2
- 2. *Guarantee and Liability* .....3
- 3. *Copyright*.....4



## Machines and Plants

# 1. *Instruction to Owner and Operators*



▶ **Employ only**

- **instructed**
- **trained**
- **reliable**

**personnel for operation, maintenance and repair.**

▶ **The operating instructions belong into the hands of the operating and maintenance personnel. The instructions contain important information the knowledge of which is indispensable for the operating and maintenance personnel to prevent maloperation, errors and portentous omissions.**

- ▶ Ask the operating and maintenance personnel to confirm that they will apply and observe the operating, maintenance and safety instructions.
- ▶ Use the machine/plant only for the proper use specified by the manufacturer.

## 2. *Guarantee and Liability*

- ▶ As a matter of principle, our "General Terms and Conditions for Sale and Delivery" shall apply, which have been sent to you on conclusion of the contract, at the latest.
- ▶ Claims for guarantee and liability for damage to people and property are excluded when they can be attributed to the following causes:
  - Operation of the machine/plant with defective safety devices or removed safety and protective devices.
  - Improper intermediate storage, erection, starting, and operation of the machine/plant.
  - Professionally improper operation and maintenance of the machine/plant.
  - Improper use of the machine/plant.
  - Faulty feeding and discharge conditions.
  - Unauthorized structural changes on the machine/plant.
  - Unauthorized change of the driving conditions (power and speed).
  - Poor surveillance of the parts which are subject to wear.
  - Cases of disaster through influences of foreign bodies and force majeure.
  - Professionally improper repair under your own responsibility.
  - Use of spare parts which are not of BHS original.

## **3.**      **Copyright**

---

- ▶ The copyright in the Operating Instructions remains with the manufacturer of the machine/plant.
- ▶ These operating instructions are destined for operating, maintenance, monitoring, and repair personnel.
- ▶ The instructions include specifications and technical documentation which must not be reproduced, distributed, used for purposes of competition or handed over to any third party, neither completely nor partially, without authorization.
- ▶ Infringements may be prosecuted.

## General Safety Instructions

# Operating Instructions

<b>1. Basic Safety Requirements.....</b>	<b>3</b>
1.1 Scope of application .....	3
1.1.1 Notes concerning 94/9/EG ATEX Ordinance .....	3
1.2 Notes regarding personnel .....	3
<b>2. Warning Notes and Warning Signs .....</b>	<b>4</b>
2.1 Markings in the Operating Instructions .....	4
2.2 Markings on BHS machines and equipment.....	4
2.2.1 Prohibitory signs.....	4
2.2.2 Warning signs .....	4
2.2.3 Signs giving orders.....	5
<b>3. Use of the Machine/Plant.....</b>	<b>6</b>
3.1 Proper Use .....	6
3.2 Improper Use .....	6
3.3 Dangers and Troubles.....	6
<b>4. Organizational Measures.....</b>	<b>7</b>
4.1 Operating Instructions .....	7
4.2 Supplements to the Operating Instructions.....	7
4.3 Working in Compliance with Safety Regulations.....	8
4.4 Unauthorized Modifications .....	8
<b>5. Personnel Requirements.....</b>	<b>9</b>
5.1 Selection and Qualification .....	9
5.2 Responsibility for operation .....	10
5.3 Responsibility for assembly .....	10
<b>6. Safety Equipment on the Machine/Plant.....</b>	<b>11</b>
6.1 Safety Measures for Machine/Plant Motors .....	11
6.2 Main Switch.....	11
6.3 Repair Switch .....	11
6.4 Emergency-Off Switch.....	11
6.5 Protection of Access or Maintenance Hatches .....	12
6.6 Safety Devices .....	12
6.7 Working and Maintenance Platforms, Catwalks .....	12
<b>7. Requirements for Machine/Plant Operation .....</b>	<b>13</b>
7.1 Safety Instructions.....	13
7.2 Safety Measures .....	13
<b>8. Requirements for Working at the Machine/Plant.....</b>	<b>14</b>
8.1 Safety Instructions.....	14
8.2 Safety Measures .....	14



# General Safety Instructions

# Operating Instructions

<b>9.</b>	<b>Particular Dangers .....</b>	<b>16</b>
9.1	Electric Power Supply .....	16
9.2	Repair .....	16
9.3	Process Materials.....	17
9.4	High-pressure water, steam, hydraulics .....	17
9.5	Thermal Hazards.....	18
9.6	Hazards as result of disregarding safety instructions.....	18
9.6.1	Unauthorised Reconstruction and Spare Part Manufacturing.....	18
<b>10.</b>	<b>Mobile Machines/Plants.....</b>	<b>19</b>



# Machines and Plants

# 1. *Basic Safety Requirements*

## 1.1 *Scope of application*

These safety requirements generally apply for intended and specified use of machines by BHS. Descriptions and instructions apply to the standard designs. Special designs not covered in this chapter are subject to the general information of this installation and assembly instructions as well as all and any additionally supplied documentation.

### 1.1.1 *Notes concerning 94/9/EG ATEX Ordinance*

The operating manual contains additional chapters concerning the 94/9/EG Ordinance which shall be observed if the machine was ordered in accordance to ATEX. This is stated in the specifications.

## 1.2 *Notes regarding personnel*

### - **Persons who are responsible for the**

- operation
- maintenance
- repair
- assembly

of the machine/plant have to

- read and observe the safety instructions carefully
- use safety equipment
- execute safety-technical requirements.
- know and observe the customer documentation.
  
- Not only the general safety information of this chapter but also respective specific safety information of the other chapters of this operating manual shall be observed.
- The technical documentation cannot cover all details of possible arrangement, equipment and production methods.
- For this reason it is recommended to contact a specialist of BHS customer service for planning, installation, commissioning and maintenance.





## 2. Warning Notes and Warning Signs

### 2.1 Markings in the Operating Instructions

- ▶ In these operating instructions all regulations, rules, and instructions concerning safety have been marked by warning signs and in addition by headings such as "**NOTE!**", "**ATTENTION!**", or "**DANGER!**".



- ▶ **NOTE!**  
this heading refers to operating and maintenance instructions which must absolutely be followed and observed.



- ▶ **ATTENTION!**  
indicates operating and maintenance procedures which must be strictly adhered to in order to prevent damage to and destruction of the machine/plant and other property.



- ▶ **DANGER!**  
indicates operating and maintenance procedures which must be strictly adhered to in order to protect life and limb of persons.

### 2.2 Markings on BHS machines and equipment

#### 2.2.1 Prohibitory signs



- ▶ No access for unauthorized persons!

#### 2.2.2 Warning signs



- ▶ Keep away from loading area!

CATION  
HAZARDOUS AREA !  
AUTHORIZED PERSONNEL  
ONLY

Unauthorized Persons  
Keep out

Authorized personnel  
only



▶ Falling hazard!



▶ Risk of getting pinched!



▶ Slippery surface!



▶ Warning of hand injuries!



▶ Warning of suspended loads!

### 2.2.3 Signs giving orders



▶ Wear safety harness!



▶ Wear hearing protectors!



▶ Wear protective helmet!

# 3. Use of the *Machine*/Plant

## 3.1 *Proper Use*

- ▶ The machine/plant may be used for its intended purpose only! The proper use of the machine/plant has been clearly stated in
  - the group "Machine description"
  - the Technical Specification.
  - the Order Acknowledgement

Any other use, or any use beyond those specifications, is regarded as improper use. The manufacturer will not be liable for any damage involved. The risk will be solely with the operator.

The proper use also includes adhering to the operating instructions, and the inspection and maintenance instructions.

- ▶ The machine/plant shall be used in technically perfect condition only; be always aware of safety and danger!

## 3.2 *Improper Use*

- ▶ It is dangerous and not allowed to use the machine/plant improperly and not to specification.
- ▶ The machine/plant will not be reliable if it is not serviced to the maintenance instructions, or if it is not serviced at all.
- ▶ The machine/plant must not be operated by unauthorized personnel!

## 3.3 *Dangers and Troubles*

- ▶ The machine/plant has been manufactured according to the state of the art and the recognized safety regulations. Nevertheless, its use may cause danger for life and limb of its operator or other persons, or can cause damage to the machine/plant and other property.
- ▶ Malfunctions in the machine/plant which may affect the safety must be eliminated immediately!

# 4. Organizational Measures

## 4.1 Operating Instructions



- ▶ One copy of the operating instructions must always be kept ready on hand at the site.

- ▶ **NOTE!**  
The personnel working at the machine/plant must

**know the operating instructions in particular the chapters concerning safety**

During work it will be too late.

This applies especially to personnel working only occasionally at the machine/plant, e.g. for maintenance and repair work.

## 4.2 Supplements to the Operating Instructions

- ▶ Observe the generally valid safety regulations and provisions of the competent trade association, and other obligatory regulations for accident prevention and environmental protection.
- ▶ Such responsibilities can also concern e.g. the handling of dangerous materials or the availability and use of protective equipment, as well as road traffic regulations
- ▶ Observe the regulations concerning special company conditions, including responsibilities for supervision and notification, e.g. with regard to organization of work, working sequences, and personnel employed.
- ▶ Make sure that the dates for possible recurrent safety checks of the machine/plant components by experts of technical surveillance association, trade association, or other authorities will be observed.

### **4.3 Working in Compliance with Safety Regulations**

- ▶ The machine/plant must always be operated in its proper condition and for its proper use as specified.
- ▶ Mind all safety and danger indications at the machine/plant and keep them all in legible condition! For example:
  - warning and instruction signs
  - rotational direction arrow on the motor
  - type label
- ▶ If necessary or specified by regulations, your personnel must wear personal safety clothing, or use protective equipment, during maintenance and repair work.
- ▶ The personnel must not wear loose and long hair, loose clothing, or jewelry (including rings). There will be danger of injury by being pulled in or getting caught!
- ▶ When carrying out maintenance work, an adequate tooling equipment is absolutely necessary!

### **4.4 Unauthorized Modifications**

- ▶ Should the operational behavior change power down the machine and installation and report fault to the responsible office/person!
- ▶ Any modifications, attachments and conversions on the machine/plant which may affect the safety and function must not be made!
- ▶ Any changes of program (software) for programmable control functions on the machine/plant are permitted only after approval by the manufacturer!

# 5. Personnel Requirements

## 5.1 Selection and Qualification

- ▶ Work on/with the machine/plant must be made by reliable personnel only. Mind the legal minimum age! Make sure that only instructed personnel will work at the machine/plant.
- ▶ Employ only trained and instructed personnel and clearly define the responsibilities of the personnel for operation, set-up and shut-down, maintenance, and repair!
- ▶ Authorities, responsibilities, and the supervision of the personnel need to be precisely determined by the operator. In case the personnel does not have the necessary knowledge, they need to be instructed and trained. This can be done if necessary on behalf of the operator of the machine by the manufacturer/supplier.
- ▶ Furthermore the operator must make sure that the contents of the operating manual are fully understood by the personnel.
- ▶ Personnel just being trained, instructed or generally educated may work at the machine/plant only under the constant supervision of an experienced person!
- ▶ We recommend that the support and services offered by BHS technicians be called upon for planning, assembly, commissioning, and service tasks.



- ▶ **NOTE!**  
**The instructions of this operating manual are not training materials and cannot replace training and professional experience required for these tasks!**  
If required qualification (completed professional education as engineering fitter-machinist in accordance to German standards and several years of professional experience) cannot be met, it is recommended to entrust the manufacturer of the machine with the required duties.



- ▶ **NOTE!**  
Maintenance and repair work on electrical, mechanical, hydraulic and pneumatic equipment at the machine/plant shall be carried out only by a qualified expert having special knowledge and experience in the respective field and working in accordance with the existing regulations.

### 5.2 **Responsibility for operation**

- ▶ Define the responsibility of the machine/plant foreman, also with regard to road traffic regulations, and enable him to refuse the instructions of any third person if those instructions are contradictory to safety.

### 5.3 **Responsibility for assembly**



- ▶ **NOTE!**  
If the assembly of the machine/plant is not included in the BHS scope of supply, the BHS specialist will be responsible only for supervising the assembly sequence. He is not responsible for observing the respective statutory provisions, training, instruction and watching the assembly personnel. Assembly shall be organized by the respective company.

## 6. Safety Equipment on the Machine/*Plant*

### 6.1 *Safety Measures for Machine/Plant Motors*

- ▶ As electric safety measures motor fuse protections, protective motor switches, possibly resistor temperature probes, and fault current circuit breakers are to be provided.

### 6.2 *Main Switch*

- ▶ It must be possible to shut off the supply of electric energy to the machine/plant by means of a lockable main switch in the control cabinet.

### 6.3 *Repair Switch*

- ▶ For each machine/plant there must be an all-pole, lockable switch-off unit, in its immediate neighbourhood or on the machine/plant itself; the switch positions "Ein" (ON) and "Aus" (OFF) must be clearly visible.
- ▶ Starting the machine/plant from any other point must be possible only when switch position "Ein" (ON) is in permissive position.

### 6.4 *Emergency-Off Switch*

- ▶ For each machine/plant there must be a noticeable red emergency-off switch in its immediate vicinity or on the machine/plant itself, by which in case of danger the machine/plant drive and the material supply to the machine/plant can be switched off.



## 6.5 *Protection of Access or Maintenance Hatches*

- ▶ The access or maintenance hatches must be protected by one of the following means:
  - Electric safety limit switch and electromagnetic locking unit
  - Combined switch for limit and locking connection
  - Mechanical safety locks
- The safety limit switches must be connected to the control in a way that the machine/plant cannot be started if the access or maintenance hatches are open.  
The locking unit must be connected to the control in a way that, when the machine/plant has been switched off, the access or maintenance hatches can be opened only after the moving parts have come to complete standstill.  
The time to be set on the time lag relay of the locking unit should at least correspond to the coasting period of the moving parts.
- The keys for the safety locks must be kept under lock and key by the person responsible for the machine/plant.

## 6.6 *Safety Devices*

- ▶ For V-belt drives, couplings and working cylinders, safety devices are provided that are constructed according to the prevailing regulations for the prevention of accidents.

## 6.7 *Working and Maintenance Platforms, Catwalks*

- ▶ If these are necessary for operation reasons, then they must be designed in a way that they meet the requirements to be expected. They must be of adequate size.
- ▶ When there is risk of falling, safety devices must be provided in accordance with the prevailing regulations for the prevention of accidents.

# 7. Requirements for Machine/Plant *Operation*

## 7.1 *Safety Instructions*

- ▶ Observe the instructions and measures specified in the Operating Instructions, they apply to automatic as well as hand operation!
- ▶ Prior to switching on and starting the machine/plant make sure that nobody will be endangered by the starting of the machine/plant!
- ▶ Any method of operation that may affect safety must be avoided!
- ▶ Mind the control indications during the starting and stopping operations!
- ▶ Do not switch off or remove any extraction or ventilation equipment when machine/plant is running!

## 7.2 *Safety Measures*

- ▶ Set selector switch to Automatic or Manual Operation!
- ▶ Take measures to ensure that machine/plant will be operated in safe and proper condition only! Operate the machine/plant only if all safety and protection equipment, e.g. detachable protection devices, emergency-off devices, sound insulations, extraction systems are existing and operative!
- ▶ In case of malfunctions, stop and secure the machine/plant immediately! Have all malfunctions rectified as soon as possible!
- ▶ At least once per shift check machine/plant for any defect or failure that can be detected from outside! Report any deviations (also in operating performance) immediately to the responsible office/person! If necessary, stop and secure the machine/plant immediately!

# 8. Requirements for Working at the Machine/Plant

## 8.1 Safety Instructions

- ▶ The instructions and measures specified in the Operating Instructions for maintenance, inspection, and operation must be observed and adhered to!
- ▶ The adjusting, maintenance, inspection, and repair actions (including replacement of wearing and machine parts) specified in the Operating Instructions must be observed and carried out in compliance with the safety instructions!
- ▶ Inform the operating personnel prior to commencing any repair and maintenance work, and appoint a supervisor!
- ▶ For all work on the machine/plant concerning operation, change of control functions, conversion of the machine/plant and its safety equipment, as well as inspection, maintenance, and repair, the instructions regarding safety, starting and stopping operations, and proper repair must be observed and adhered to!
- ▶ Any fuel and process materials, as well as replaced parts must be discarded in a safe and environmentally harmless way.

## 8.2 Safety Measures

- ▶ Protect a wide area - when applicable - around the repair location!
- ▶ When the machine/plant has been completely switched off for inspection, maintenance or repair work, it must be secured against unexpected restarting:
  - Lock the main switch (also repair switch) and take key along.
  - Attach warning sign at the main switch.
- ▶ Clean the machine/plant prior to commencing maintenance and repair work! Prior to cleaning, e.g. with water or steam jet (low pressure) or other cleaning agents, cover or - if necessary - tape up all openings or devices, into which water / steam / cleaning agent must not penetrate for reasons of safety or proper function.
  - Electric motors, switches, valves, and switch cabinets are particularly susceptible!
  - Only dry cleaning for all dosing and feeding devices for dry aggregates!
  - Do not use aggressive cleaning agents!
  - Electric devices and installations without the necessary protection must not be treated with water or steam jet.

- ▶ After the machine/plant has been cleaned, remove again all coverings and tape seals completely!
- ▶ After having cleaned air and oil lines, check them for leakage, loose connections, abraded spots, and damage!  
Any defects detected must be repaired immediately!
- ▶ If the dismantling of safety devices is required during maintenance and repair work, those safety devices must be installed again after the completion of the work and their proper function be tested!
- ▶ Machine parts and large assemblies must be carefully fixed to the lifting devices and secured during replacement so that they will be no source of danger. Suitable and technically faultless lifting devices as well as load carrying means with adequate capacity must be used only.

Do not stay or work under suspended parts!

- ▶ Experienced persons only must be engaged for the slinging of loads or the guiding-in of crane drivers! The guider must be within sight of the crane driver or be in speech contact with him.
- ▶ In case of assembly or repair work above body height use the intended or other safe ladders or work platforms.
- ▶ Do not use machine parts as climbing aids!
- ▶ Keep all handles, steps, railings, landings, platforms, and ladders free from dirt, snow and ice!



- ▶ **NOTE!**  
When working at greater heights use guard rails!
- ▶ Bolt connections loosened during maintenance and repair work must be tightened again after completion of the work, taking into consideration any specified tightening torques (see technical documentation)!

# 9. Particular Dangers

## 9.1 Electric Power Supply



- ▶ **ATTENTION!**  
Work on electrical installations or equipment must be carried out only by an electrician or by instructed personnel under the supervision of an electrician in accordance with the rules of the electrical engineering industry!
  
- ▶ The electrical equipment of the machine/plant must be inspected and checked regularly. Any defects such as loose cable connections or scorched cables must be analysed and repaired immediately!

## 9.2 Repair



- ▶ Repair work on machine/plant to be carried out only after explicit approval!
  
- ▶ **NOTE!**  
Work on electric, hydraulic, pneumatic, mechanic equipment must be executed only by persons who have special technical knowledge in the respective field and observe the prevailing rules!
  
- ▶ Prior to commencing repair, depressurize any system, sections and pipes for compressed oil or air which must be opened. For example, spurting oil may cause injuries or fire! Adequate feed/intake/uptake and disposal of substances must be ensured
  
- ▶ Prior to commencing welding and flame-cutting work, clean the working place of all dust and grease, and remove all flammable material around it. Make sure that adequate ventilation is provided; there may be fire or explosion hazard!
  
- ▶ During electric welding disconnect or remove the electronic insert cards to avoid possible damages by welding current. Also ensure very good bonding around the welding point (remove dirt and paint).
  
- ▶ During electric welding on the machine/plant, which has to be done in moist areas, there is danger of electric shock!
  - Make sure that the welder's place is properly isolated, otherwise welding work must not be carried out under those circumstances!
  
- ▶ When working in confined spaces observe any prevailing national regulations!

### 9.3 Process Materials

- ▶ In the course of feeding suspension and/or possible required washing liquids emissions of product vapors may occur which in general should be vacuumed off by an in-plant air conditioning system. When using CIP liquids (acids, bases) for cleaning the required security precautions are obligatory (e.g. PSE).
- ▶ If your machine is equipped with parts made of plastic then it is not considered fire proof.
- ▶ The location type for installation (e.g. EX zone) is specified and stated on the machine plate. All materials in operation (e.g. filtrate and washing substances) are also determined in the specification. Observe respectively applicable fire prevention measures.
- ▶ When handling oil, fats and other chemical substances mind the applicable safety regulations for the respective product.
- ▶ Be careful when handling hot process materials; risk of burning or scalding!

### 9.4 High-pressure water, steam, hydraulics

- ▶ The applicable safety regulations must be observed for hose lines and connections, particularly with regard to the durability, checking and changing of hose lines. It is imperative to adhere to the checking and changing intervals.
- ▶ At control system level it is necessary to make sure that no hazards whatsoever are capable of occurring as a result of unintentional start-up.
- ▶ **ATTENTION!**  
Before starting any work on the system, always make sure that the electrical power is switched off and can't be switched on again!
- ▶ Accumulators must be completely depressurised before removing valves and pipe runs.
- ▶ Valve and equipment fastening screws must only be re-tightened in a non-pressurised state.
- ▶ Screw unions must only be re-tightened in a non-pressurised state.
- ▶ Pre-filling an accumulator on the gas side must only be done using the prescribed medium.
- ▶ Leaks from the unit, pipe runs and user may cause significant damage to the environment



## 9.5 Thermal Hazards

Thermal hazards exist in case of contact with hot machine parts or surfaces such as housing or piping. This may result in burns of the skin for contact with surfaces exceeding 50°C temperature.

The operating temperature of your machine can be found in the technical specifications.

## 9.6 Hazards as result of disregarding safety instructions

Disregarding safety instructions may result in danger to life and pose a hazard to equipment or environment. Disregarding safety instructions can result in loss of liability claims. As concrete examples disregarding safety instructions result in following risks:

- Failure of important/relevant machine functions
- Failure of specified maintenance and service procedures/processes
- Hazard to health and life by electrical, mechanical and chemical influences
- Environmental hazard as result of discharge of hazardous substances

### 9.6.1 Unauthorised Reconstruction and Spare Part Manufacturing



▶ **NOTE!**

The operator assumes responsibility for safety when he reconstructs or changes the machine/plant unauthorised.

**The warranty given by BHS-Sonthofen GmbH is cancelled in such a case!**

- ▶ Original spare parts and accessories authorised by the manufacturer serve safeness. Using other parts can cancel the manufacturer's liability for resulting consequences.

# 10. Mobile Machines/Plants

- ▶ The following refers to machines/plants that frequently change sites.
- ▶ Use only lifting devices and load carrying means with adequate capacity and experienced guiders for the process of loading.
- ▶ Sling, lift with lifting devices and load the machine/plant only in accordance with the Operating Instructions, Group: Delivery and Intermediate Storage.
- ▶ Only use suitable vehicles with sufficient capacity for transport!
- ▶ The load must be reliably protected with the recommended or delivered devices against lengthwise and crosswise slipping; the suitable sling points must be used!
- ▶ Use warning signs in case of surpassing the loading gauge!
- ▶ Before recommissioning carefully mount those parts or part groups which had to be dismantled for reasons of transport!
- ▶ For recommissioning proceed only in accordance with the operating instructions.



## Delivery and temporary storage

# Operating instructions

<b>1.</b>	<b><i>Delivery condition</i></b> .....	<b>2</b>
<b>1.1</b>	<b><i>Delivery scope</i></b> .....	<b>2</b>
<b>1.2</b>	<b><i>Extent of disassembly</i></b> .....	<b>2</b>
<b>1.3</b>	<b><i>Operational readiness</i></b> .....	<b>2</b>
<b>2.</b>	<b><i>Transport</i></b> .....	<b>3</b>
<b>2.1</b>	<b><i>Mode of transport</i></b> .....	<b>3</b>
<b>2.2</b>	<b><i>Type of packaging</i></b> .....	<b>3</b>
<b>2.3</b>	<b><i>Dimensions and weight</i></b> .....	<b>4</b>
<b>2.4</b>	<b><i>Attach for transport purposes</i></b> .....	<b>4</b>
<b>2.5</b>	<b><i>Loading</i></b> .....	<b>4</b>
<b>2.6</b>	<b><i>Transport operation</i></b> .....	<b>5</b>
<b>3.</b>	<b><i>Temporary storage</i></b> .....	<b>6</b>
<b>3.1</b>	<b><i>Storage prior to installation</i></b> .....	<b>6</b>
<b>3.2</b>	<b><i>Preservation measures for temporary storage</i></b> .....	<b>6</b>
<b>3.2.1</b>	<b><i>External conservation for protected, dry and temperature-controlled storage inside buildings</i></b> .....	<b>6</b>
<b>3.2.2</b>	<b><i>External preservation for protected storage in the open air</i></b> .....	<b>7</b>
<b>3.3</b>	<b><i>Preserving measures for drive elements</i></b> .....	<b>7</b>
<b>3.3.1</b>	<b><i>Components installed in rotary mountings</i></b> .....	<b>7</b>
<b>3.3.2</b>	<b><i>Gearbox</i></b> .....	<b>7</b>
<b>3.3.3</b>	<b><i>Motors</i></b> .....	<b>7</b>
<b>3.3.4</b>	<b><i>Pneumatic cylinders, valves, grease pump lubricating unit</i></b> .....	<b>7</b>
<b>3.3.5</b>	<b><i>Hydraulic cylinders, hydraulic unit</i></b> .....	<b>7</b>
<b>3.4</b>	<b><i>Preserving measures for control unit</i></b> .....	<b>7</b>
<b>3.5</b>	<b><i>Preserving measures for plant components from sub-contractors</i></b> .....	<b>7</b>
<b>4.</b>	<b><i>Temporary storage after completion of commissioning process</i></b> .....	<b>8</b>
<b>4.1</b>	<b><i>Extended downtime inside buildings</i></b> .....	<b>8</b>
<b>4.2</b>	<b><i>Extended downtime in open-air locations</i></b> .....	<b>8</b>
<b>5.</b>	<b><i>Measures after temporary storage</i></b> .....	<b>9</b>
<b>5.1</b>	<b><i>Gearboxes and oil-filled assemblies</i></b> .....	<b>9</b>
<b>5.2</b>	<b><i>Motors</i></b> .....	<b>9</b>
<b>6.</b>	<b><i>Guarantee and warranty claims</i></b> .....	<b>9</b>

# 1. *Delivery condition*

## 1.1 *Delivery scope*

- ▶ The delivery scope complies with the order confirmation or the dispatch note that also includes details of the packing units.
- ▶ At the incoming goods inspection, the delivery must be checked for:
  - Completeness
  - Damage in transit
  - Missing parts
- ▶ Report defects to the transport company immediately.

The transport company is obliged to record and report damage in writing to the insurance company responsible and/or to those who took out the insurance cover.

## 1.2 *Extent of disassembly*

- ▶ Normally the machine/plant is supplied in an assembled condition.  
It is, however, possible to supply it in several assembly modules.
- ▶ The extent of disassembly ('knock-down') depends upon the
  - transport conditions
  - local construction site conditions
  - available lifting equipment

## 1.3 *Operational readiness*

- ▶ Test run on manufacturer's premises independently of subsequent delivery condition and level of disassembly.
- ▶ With plant that cannot be assembled for test purposes, no test run is conducted.

## 2. Transport

### 2.1 Mode of transport

- ▶ The mode of transport depends upon the
  - transport routes
  - instructions from the customer.
- ▶ Possible modes of transport are:
  - truck
  - train
  - ship
- ▶ The required mode of transport will be agreed with the customer in good time prior to delivery.



- ▶ **NOTE!**  
Report damage in transit to the transport company and to the insurance company in writing (see scope of delivery).
- ▶ For transport purposes, the load must be secured to prevent it from slipping.

### 2.2 Type of packaging

- ▶ The transport route is a co-determining factor for the type of packaging.
- ▶ The types of packaging:
  - Open loading
  - Container loading
  - Crate packaging

shall comply, unless otherwise contractually stipulated, with the HPE packaging directives of the *Deutscher Bundesverband Holzmittel, Paletten, Exportverpackung e. V.* and by the Association of German Mechanical Engineering Institutions (the VDM).

- ▶ The type of packaging shall be defined in the order confirmation document.
- ▶ Pay attention to the symbols attached to the packaging:



Oben



Zerbrechliches  
Gut



Vor Nässe schützen



Vor Hitze schützen



Handhaken  
verboten



Schwerpunkt

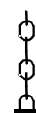

Anschlagen  
hier

### 2.3 Dimensions and weight

- ▶ Transport dimensions and machine/plant weights - refer to the technical specification and to the technical documentation: Installation drawing.
- ▶ See dispatch papers for precise weight of shipment.

### 2.4 Attach for transport purposes



- ▶ **CAUTION!**  
Open loading.  
Attach the machine using the eyelets provided.  
The suspension equipment must not be at an angle of less than 45° to the horizontal plane!

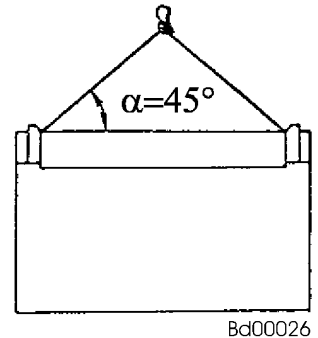

- ▶ Excessive torsion must be avoided when suspending the machine/plant, as this might cause damage due to deformation.
- ▶ Pay attention to specific instructions governing the transport of the entire machine and/or individual parts of it (see chapter 5 Assembly and Electrical Connection)!
- ▶ **Crate packaging**  
Attach the crate at the points indicated by symbols.

### 2.5 Loading

- ▶ For loading purposes, the load must be secured to prevent it from slipping.
- ▶ The load surface must be flat and as torsionally rigid as possible.

## 2.6 Transport operation



- In all cases, observe all notice symbols on the transport packaging during all transport operations.
- During transport operations, and with storage of the rotary pressure filter, fit caps to all flange connections to protect them.
- While transporting a load, maintain a suitable safety distance.
- Only use permitted lifting gear that is in good operational condition.
- Adjust the length of lifting gear until the machine is suspended in a horizontal position.
- Do not remove any supports or documents that are attached to the machine.

- ▶ Crane equipment, lifting gear and transport cables must be appropriately dimensioned.
- ▶ Before you lift the machine, please note the weight indicated on the type plate. Please only use cranes and lifting gear with sufficient lifting capacity.

When transporting the machine/plant, proceed carefully to prevent damage caused by the application of force or careless loading and unloading.

## 3. Temporary storage

### 3.1 Storage prior to installation

- ▶ Requirements for the storage location of the machine/plant:
  - protected
  - free from mechanical vibration (shaking)
  - free from the effects of dust and humidity
  - free from the influence of aggressive chemical substances
  - Lower temperature limit - 30°C
  - Flat and firm installation surface
- ▶ Type of temporary storage:
  - Best temporary storage in temperature-controlled buildings
  - Avoid unprotected storage in the open air. If unavoidable, then only
    - for short periods.
    - Adopt protective measures against inclement weather conditions, e.g. fit a flat wooden cover over the top, covered by plastic sheeting
    - Set up the machine/plant properly on a flat and stable surface. If necessary, place the machine/plant on wooden beams.
    - Protect plastic and rubber components from direct sunlight.

### 3.2 Preservation measures for temporary storage

- ▶ Carry out if no specific preservation measures have been agreed contractually. (after a storage time of approx. 5 months).
- ▶ Please also note the manufacturer's instructions on storage in the operating manual for the individual components.
- ▶ Please monitor the preserved condition on a regular basis throughout the time in storage.

#### 3.2.1 External conservation for protected, dry and temperature-controlled storage inside buildings

- Spray all bolt connections, joints, stud bearings and untreated turned components with rust-stripping or corrosion-inhibiting oil (do not spray rubber components such as V-belts, springs and coupling elements!).
- Repeat the external preservation in accordance with requirements (no later than after 12 months).

### **3.2.2 External preservation for protected storage in the open air**

- If stored under cover in the open-air, spray all bolt connections, joints, stud bearings and untreated turned components with rust-stripping or corrosion-inhibiting oil (do not spray rubber components such as V-belts, springs and coupling elements). Do so for the first time when these items are placed into storage.
- Repeat the external preservation in accordance with requirements (no later than after 6 months).

### **3.3 Preserving measures for drive elements**

#### **3.3.1 Components installed in rotary mountings**

- ▶ At 3-month intervals, rotate through 2-3 complete turns

#### **3.3.2 Gearbox**

- ▶ Please note the instructions for storage in the manufacturer's operating instructions (see Technical Documentation)

#### **3.3.3 Motors**

- ▶ Please note the manufacturer's instructions on storage in the operating instructions

#### **3.3.4 Pneumatic cylinders, valves, grease pump lubricating unit**

- ▶ Please note the manufacturer's instructions on storage in the operating instructions

#### **3.3.5 Hydraulic cylinders, hydraulic unit**

- ▶ Please note the manufacturer's instructions on storage in the operating instructions

### **3.4 Preserving measures for control unit**

- ▶ Please note the manufacturer's instructions on storage in the operating instructions

### **3.5 Preserving measures for plant components from sub-contractors**

- ▶ Please note the manufacturer's instructions on storage in the operating instructions

# 4. *Temporary storage after completion of commissioning process*

## 4.1 *Extended downtime inside buildings*

- ▶ The storage location is temperature-controlled and dry.
- ▶ Clean machine/plant inside and outside, then leave to dry.
- ▶ Carry out preserving measures on assemblies in accordance with manufacturer's specifications (operating instructions).
- ▶ Repeat these preserving measures after about 9 months.
- ▶ **Other instructions**
  - Refer to temporary storage for this group
  - Refer to technical documentation
- ▶ If recommissioned, refer to Group. Commissioning & Operation.
- ▶ Please also note the manufacturer's instructions on storage in the operating manual for the individual components.

## 4.2 *Extended downtime in open-air locations*

- ▶ Machine/plant must be protected against inclement weather conditions.
- ▶ Must not be kept unused for longer than two years.
- ▶ Clean machine/plant inside and outside, then leave to dry.
- ▶ When the machine/plant is running, fill all bearings and gasket seals with grease. When the machine/plant is stationary, pack the motor bearings with grease. On all shaft access points and motor connection box covers, seal with rolling bearing grease. Refer to Group: Lubrication.
- ▶ All gearboxes and oil-filled assemblies must be filled with the correct grade of oil in accordance with the operating instructions.
- ▶ Please also note the manufacturer's instructions on storage in the operating manual for the individual components.
- ▶ **NOTE!**
  - Refer to temporary storage.
  - Refer to technical documentation: Refer to operating instructions.



## 5. Measures after temporary storage

### 5.1 Gearboxes and oil-filled assemblies

- ▶ Replenish oil in all gearboxes and assemblies in accordance with the stipulations in the manufacturer's operating instructions.
- ▶ Check seals and gaskets for signs of ageing. Unfavourable storage conditions can cause premature ageing of the sealing elements.
- ▶ During the commissioning process, observe the sealing elements and replace them if they leak.



- ▶ **NOTE!**  
For commissioning after a longer break, see the section: Commissioning and Operation.
- ▶ Refer to technical documentation: separate operating instructions.
- ▶ Please also note the manufacturer's instructions on storage in the operating manual for the individual components.

### 5.2 Motors

- ▶ Please also note the manufacturer's instructions on storage in the operating manual for the individual components.

## 6. Guarantee and warranty claims

- ▶ For damage that occurred inside and outside on the machine/plant that is the result of incorrect temporary storage, no guarantee or warranty claims can be enforced.



## Machine Description

# Operating Instructions

<b>1.</b>	<b>General View .....</b>	<b>2</b>
<b>2.</b>	<b>Design .....</b>	<b>3</b>
<b>2.1</b>	<b>Basic Equipment.....</b>	<b>3</b>
<b>2.2</b>	<b>Additional Equipment (optional).....</b>	<b>4</b>
<b>3.</b>	<b>Mode of Operation .....</b>	<b>5</b>
<b>3.1</b>	<b>Feeding of the Mixer .....</b>	<b>5</b>
<b>3.2</b>	<b>Discharge of the Mixer.....</b>	<b>5</b>
<b>3.3</b>	<b>Mixing Capacity.....</b>	<b>6</b>
<b>3.4</b>	<b>Sense of Rotation of the Mixing Shafts.....</b>	<b>6</b>



## Twin-Shaft Batch Mixer

# 1. General View

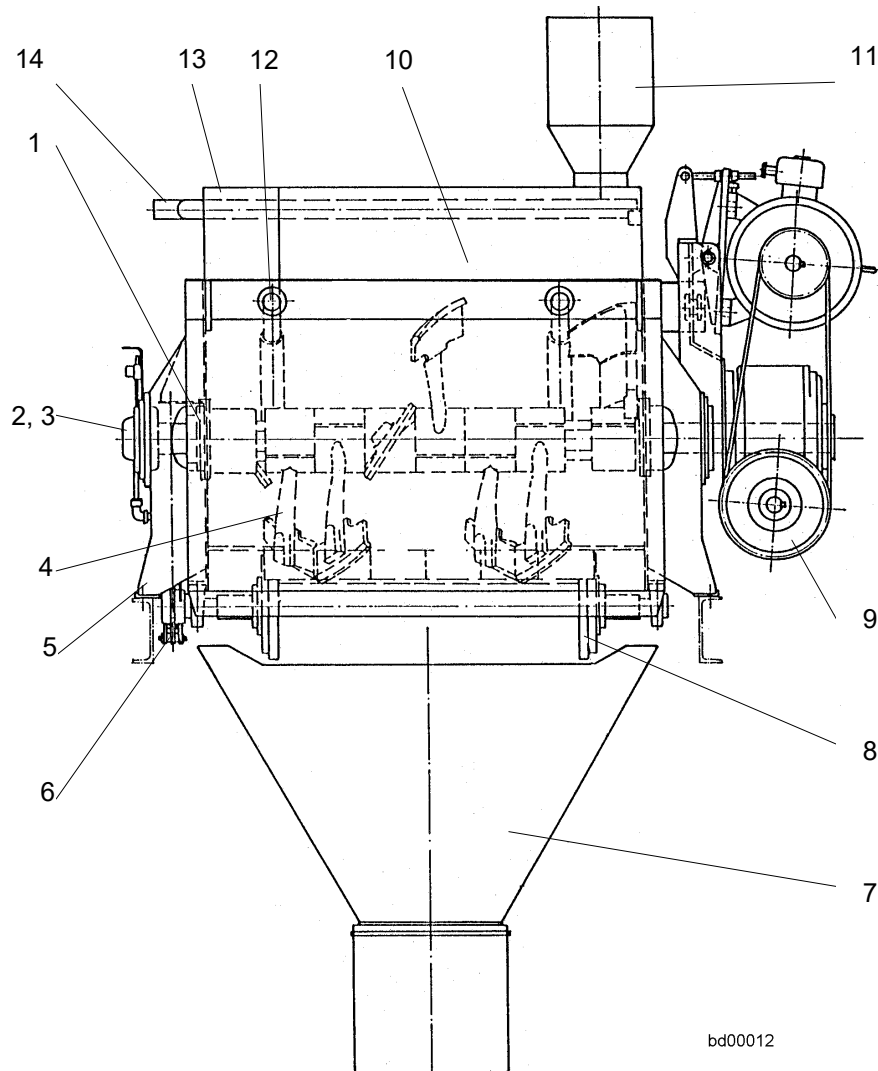

bd00012

Pos.	Description
1	Trough sealing
2	Bearings
3	Mixing shafts
4	Mixing tools
5	Supporting claws
6	Discharge door/flap operation
7	Discharge hopper
8	Discharge door /Discharge flap
9	Mixer drive
10	Mixing trough, trough wearing parts
11	Filter, airbag (optional)
12	Steam blowing (optional)
13	Trough cover
14	Water spraying

## 2. Design

The mixer has been designed according to the modular principle and may thus be supplied in different executions

### 2.1 Basic Equipment

- ▶ **Mixing Trough**
  - welded design
  - 4 supporting claws for fixing in the steel structure or on convenient concrete foundation
  - 4 suspension eyes
  - exchangeable wear protection for front and bottom sides
  - symmetric wearing elements, exchangeable to each other, with patented design and increased service life
  - special lining (ceramic, rubber, plastic material, composite sheets, etc.) is possible
  
- ▶ **Mixing tools**
  - 2 horizontal mixing shafts with self-aligning roller bearings
  - mixing arms arranged in helical line, which is advantageous for the mixing process and energy saving
  - central and lateral arms of special steel casting
  - mixing technically optimized design of mixing arms
  - mixing blades and exchangeable wearing elements made of highly wear resistant special hard casting
  - special blades (plastic/steel, composite sheet, etc.) are possible.
  
- ▶ **Mixing Trough Sealing**
  - reliable axial face sealing
  
- ▶ **Discharge Door /Discharge Flap in the trough bottom**
  - revolving seating
  - adjustable sealing ledges
  
- ▶ **Discharge Door/ Discharge Flap Operation**
  - opening and closing via pneumatic cylinder. Optionally this can be carried out by hydraulic cylinders or electrically with a gear motor
  - protective hood over the working cylinders

- ▶ **Mixer Drive**
  - Slip on drive units, consisting of:
    - > slip-on worm gear
    - > torque support
    - > motor console
    - > motor
    - > V-belt drive
  - synchronization of drive unit via coupling
  - speed control (optional)
  - small mixers are provided with single motor drive, bigger ones with double motor drive
  - protective hoods on V-belt drive and synchronous coupling
  - A drive unit can be installed on each lateral side at selected mixer sizes.

## 2.2 Additional Equipment (optional)

- ▶ **Trough Cover**
  - welded design
  - electrically protected maintenance doors
  - water spraying
    - > admission of metered water quantity
    - > used and clean water design
  - central entries for aggregates and binders
  - connecting sleeve for filter and airbags
- ▶ **High-Pressure Cleaning Plant**
  - mixer cleaning to reduce manual attendance
  - nozzles installed in the trough cover
  - high-pressure aggregate with control
- ▶ **Central Grease Lubrication or oil-air**
  - Different variants of design
    - > for the 4 lubricating points of the inner sealing chamber of the mixing trough
    - > all lubricating points of the mixer
    - > oil or grease lubrication or combinations interval control and manual release optional
  - Installation of the lube unit on the mixing trough or near the mixer
- ▶ Exact description: see group „Lubrication“
- ▶ **Device for Steam Blowing**  
to produce heated concrete
  - steam lances on both sides in the upper trough area



## 3. *Mode of Operation*

- ▶ The Twin-Shaft Batch-Mixer is, from the function's point of view, a batch mixer, e.g. for fresh concrete, to which aggregates, binding agent, water and special additives are supplied from above in certain feeding intervals.
- ▶ The counter-rotating and synchronously running mixing shafts, equipped with the mixing tools, effect true compulsory mixing.
- ▶ In the mixing trough the material is compulsorily mixed horizontally and vertically, and moved in a circle by the rotating tools, working in opposite direction. This results in optimum homogeneity of the mix within shortest possible mixing time.

### 3.1 *Feeding of the Mixer*

- ▶ The mixer can be fed in automatic or manual operation. For the most important instructions for mixer feeding refer to Commissioning and Operation
- ▶ For the most important instructions for mixer feeding, refer to "Commissioning and Operation"



### 3.2 *Discharge of the Mixer*

- ▶ Discharge of the mixer can be made in automatic or manual operation.
- ▶ The mixer discharges through a discharge door/ flap with adjustable opening positions directly into the discharge hopper. The width of the opening and the opening time depend on the vehicles to be charged (truck mixers or trucks) and the concrete consistency. For the most important instructions for mixer discharge refer to Commissioning and Operation
- ▶ For the most important instructions for mixer discharge, refer to "Commissioning and Operation"



### 3.3 *Mixing Capacity*

- ▶ The efficiency of the mixer depends on the volume of the product to be mixed during feeding and during the mixing process and on the amount of filling.  
The admissible values are indicated in the technical specification.
- ▶ The required settings of feeding time and sequence as well as discharge time are plant-specific parameters. Basically, all ingredients of the mix must be metered individually (e.g. steel fibers isolated to prevent balling of the fibers)
- ▶ It may be necessary to reduce the degree of filling or to reinforce the drive unit in case of:
  - high share of fines in the mix
  - very stiff consistency
  - using chemical additives
  - Using special additives (such as steel fibers)
  - Feeding sequences deviating from the recommended specifications (see group Commissioning and Operation)
  - Mixing special products
- ▶ In order to avoid machine overload, the proportions of the mix design should be changed.
  - selectively with reduced degrees of filling and
  - under observation of the current consumption/drive power

### 3.4 *Sense of Rotation of the Mixing Shafts*

- ▶ The synchronously rotating mixing shafts are moving in counter rotation and the sense of rotation of both mixing shafts must be such that the mixing tools between both shafts run upward, according to the sketch on the right.

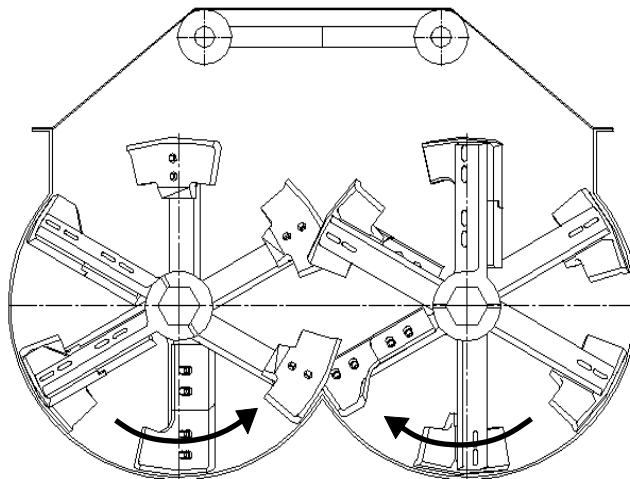

Sketch: Sense of rotation of mixing shafts

## Assembly and Electrical Connection

# Operating Instructions

<b>1.</b>	<b>General Instructions .....</b>	<b>2</b>
<b>2.</b>	<b>Assembly Instructions.....</b>	<b>3</b>
<b>2.1</b>	<b>Mechanical work .....</b>	<b>3</b>
<b>2.2</b>	<b>Testing operations before tightening the mixer fixing screws.....</b>	<b>4</b>
<b>2.3</b>	<b>Transport safety.....</b>	<b>4</b>
<b>2.3.1</b>	<b>Safety of the discharge door .....</b>	<b>4</b>
<b>2.3.2</b>	<b>Safety of the discharge flap.....</b>	<b>5</b>
<b>2.4</b>	<b>Welding work.....</b>	<b>5</b>
<b>3.</b>	<b>Electric Connection .....</b>	<b>6</b>
<b>3.1</b>	<b>General prescriptions .....</b>	<b>6</b>
<b>3.2</b>	<b>Mixer motor .....</b>	<b>6</b>
<b>3.3</b>	<b>Check and adjust direction of rotation of mixing shafts... 7</b>	<b>7</b>
<b>3.3.1</b>	<b>Rotation of mixing shafts .....</b>	<b>7</b>
<b>3.3.2</b>	<b>Checking the direction of rotation in case of a double-motor drive .....</b>	<b>7</b>
<b>3.3.3</b>	<b>Checking the direction of rotation in case of a four-motor drive 7</b>	<b>7</b>
<b>3.4</b>	<b>Access/maintenance doors in the trough cover.....</b>	<b>8</b>
<b>3.5</b>	<b>Hydraulic drive .....</b>	<b>8</b>
<b>3.6</b>	<b>Central lubrication .....</b>	<b>8</b>



# 1. *General Instructions*



- ▶ **NOTE!**  
For safety instructions and safety requirements, see
  - > Group: User information
  - > Group: General safety instructions



- ▶ **NOTE!**  
Many years of experience have shown that it is recommended to use the machine manufacturer's skilled personnel to assemble the machine. This is not only advisable for warranty reasons but also beneficial from the aspect of the professional advice given and checks performed:
  - Identification of transit damage
  - Observation of control instructions and measures at the assembly stage
  - Information on operating the machine



- ▶ **NOTE!**  
Before using the machine for its intended purpose after a prolonged intermediate period in storage, see chapter: "Delivery and Intermediate Storage"

## 2. Assembly Instructions

### 2.1 Mechanical work

- ▶ Technical Documentation: Installation Drawing

- connecting dimensions
- machine weight
- static and dynamic load indications



- ▶ **ATTENTION!**

- > Open loading.
- > Only attach the machine to the special eyelets
- > The pull direction of the suspension gear to the horizontal may not fall below an angle of 45°!



When suspending the machine take care not to twist the machine/system too much to avoid deformation damage

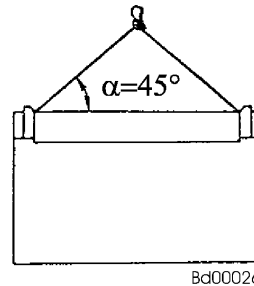

- ▶ **Installation**

- Horizontal and even
- On adequately rated steel or concrete foundation



- ▶ **ATTENTION! Welding Work**

- > connect the ground cable always directly near the treated component
- > welding current must never flow through the rolling bearings

- ▶ Ensure good **accessibility** for following maintenance and repair work:

- opening of maintenance doors in the trough cover
- change of mixing arms
- mixing shaft dismantling and mounting
- removal and installation of wearing parts
- maintenance work on the drive
- cleaning of the mixing trough interior space

- ▶ For space required, see Technical Documents: Installation drawing



## 2.2 Testing operations before tightening the mixer fixing screws

- ▶ The mixing tools should be rotated several times by hand on the V-belt drive to make sure that the lateral arms do not touch the front wall. Should this be the case, the mixing trough has got distorted while it has been placed on the steel structure. In this case, shims must be inserted under the supporting claws of the mixer.
- ▶ Check the synchronizing coupling at the mixer drive (between both gear units) in vertical and horizontal direction for true alignment. If any unacceptable alignment errors are found, these must be attributed to uneven installation of the mixer, see group: Maintenance and Inspection.
- ▶ Procedure for Mixer Alignment:
  - drive in slim steel wedges between supporting claws of the mixer and steel structure
  - repeated checks of the above mentioned controls
- ▶ Good alignment has been achieved when the lateral arms no longer touch the front walls and when the misalignment of the synchronizing coupling has been reduced to admissible tolerances.
- ▶ **NOTE!**  
Proper alignment of the mixer will prevent failures of the discharge door/ flap and the mixer drive



## 2.3 Transport safety

### 2.3.1 Safety of the discharge door

- ▶ **ATTENTION!**  
The discharge door is locked by socket pin safety..
- ▶ Loosening of locking
  - release locking screw (4)
  - pull socket pin (2) from locking pipe (3)
  - insert socket pin (2) in safekeeping eye (1)

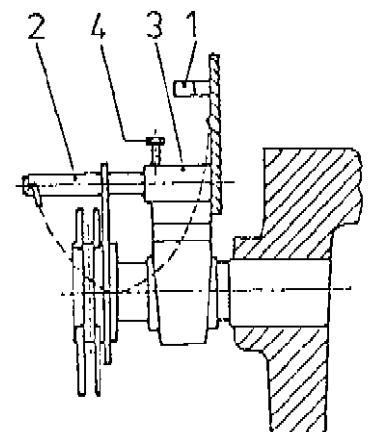

bd00022

- ▶ **DANGER!**  
For all repair work, e.g. replacement of wearing parts (mixing blades, tiles, etc.) or machine parts, insert the discharge door safety in reverse order to avoid accidents in the zone of the discharge door.



### 2.3.2 Safety of the discharge flap



- ▶ **ATTENTION!**  
Mixers with discharge flap have in the reach of the discharge hopper a transport safety



- ▶ **DANGER!**  
After connecting the discharge flap control (pneumatic or hydraulic) close the discharge flap so that the transport safety can be dismantled without danger of jamming or squeezing



- ▶ **DANGER!**  
For all work during which the discharge flap cannot be held safely in all positions because of missing pressure in the cylinders or disconnected current, the discharge flaps open due to dead weight up to the cg position. For jamming effect the flap could stop even before reaching the cg position



- ▶ **ATTENTION!**  
When working in the mixer suitable safety measures must be taken (e.g. Maintenance platforms under the mixer, safety belt for the fitter)

### 2.4 Welding work



- ▶ **ATTENTION!**  
Connect the ground cable always directly to the treated component

Welding current must never flow through the rolling bearings

# 3. Electric Connection

## 3.1 General prescriptions



▶ **DANGER!**

Admissible connected load (service/control voltage and frequencies) of motors, valves, limit switches, locking switches, central lubricating unit, must be observed, as otherwise damages and malfunctions may occur!



▶ **NOTE!**

The regulations of the local electric supply company must be observed.

Regulations (e.g. EN 57100 (VDE 0100), or EN 60204 (VDE 0113) must be observed.

## 3.2 Mixer motor



- ▶ Motor data see Technical Specification and Technical Documentation



▶ **ATTENTION!**

Check if motor bearing safety device has been unlocked / removed

- ▶ When connecting the mixer motor firmly tighten all cable connections and also check proper fit of all cables inside the mixer.
- ▶ For electrical installation consider that the mixer operates continuously at 100% connecting time.
- ▶ It is required that the nominal filling the mixer starts under load.
- Therefore, besides of the normal start in star-triangle (to start the mixer at no load), a switch for direct start under load must be provided in the control.
  - The time lag relay of the star-triangle combination has to be set to 2.5 – 3.0 sec.
- ▶ The design of the electric installation for the mixer motor must be adjusted to the a.m. loads.
- ▶ Full motor protection via thermistors with posistor temperature probes.
- ▶ We recommend installing in the control desk an ammeter for the mixer motor.

### 3.3 Check and adjust direction of rotation of mixing shafts

#### 3.3.1 Rotation of mixing shafts

- ▶ Check the direction of rotation of mixing shafts at no-load operation.
- ▶ The mixing tools must rotate towards the discharge door.

#### 3.3.2 Checking the direction of rotation in case of a double-motor drive



- ▶ **ATTENTION!**  
Prior to starting the motors together first start each motor separately and check the direction of rotation
- ▶ Only when both motors are rotating in the same direction as the mixing shafts they are allowed to be started simultaneously!

#### 3.3.3 Checking the direction of rotation in case of a four-motor drive



- ▶ **ATTENTION!**  
Check direction of motor rotation only after V-belts have been removed.
- ▶ Only when all motors are rotating in the correct direction, they are allowed to be started simultaneously!



- ▶ **ATTENTION!**  
When starting the mixer after having installed all V-belts, **turn on all motors simultaneously!**

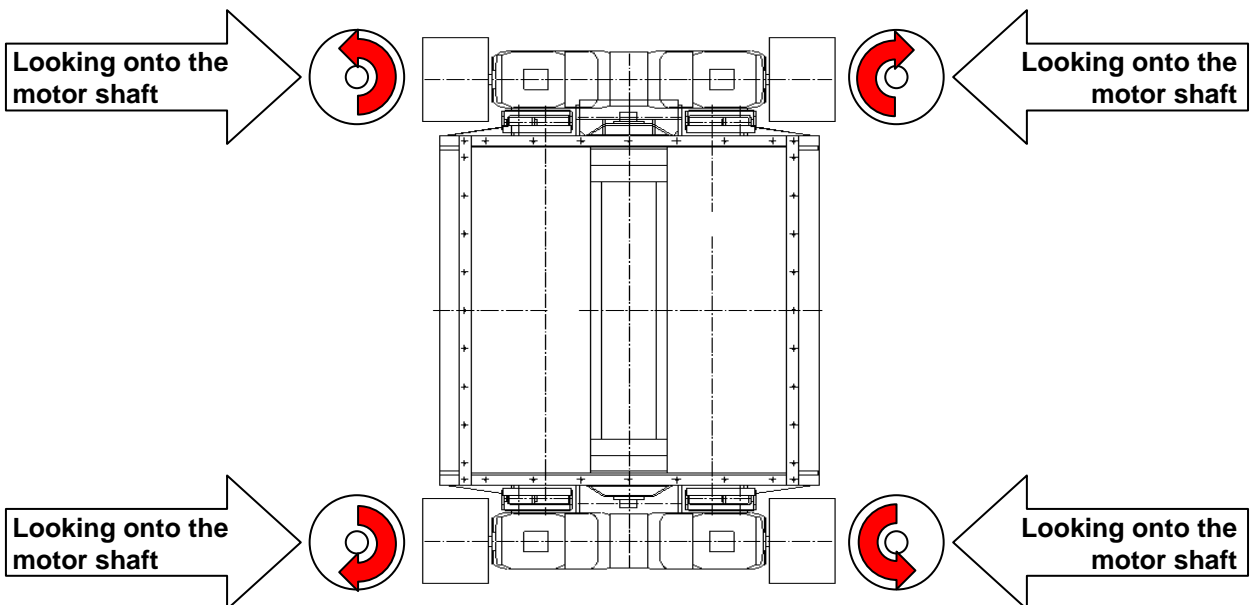



### 3.4 *Access/maintenance doors in the trough cover*

- ▶ **DANGER!**  
The access/maintenance doors are protected by a safety limit switch and a safety locking switch, see group: General Safety Instruction, Item: Safety Installation on the machine/plant - Safety of Access/ Maintenance doors
- ▶ Before commissioning, correctly connect the safety limit switch and the safety locking switch and check their function.
- ▶ Data for the safety limit switch and the safety locking switch (electromagnetic locking unit) see Technical Documentation.



### 3.5 *Hydraulic drive*

- ▶ see Technical Documents



### 3.6 *Central lubrication*

- ▶ see Technical Documents

## Commissioning and Operation

# Operating Instructions

<b>1.</b>	<b>General Instructions .....</b>	<b>3</b>
<b>2.</b>	<b>Checks prior to Starting .....</b>	<b>4</b>
2.1	Erection of the Mixer .....	4
2.2	Screw Connections.....	4
2.3	Mixing Trough .....	4
2.4	Discharge Door / Discharge Flap.....	4
2.5	Mixing Tools.....	4
2.6	Drive.....	5
2.6.1	V-Belt Drive .....	5
2.6.2	Motor.....	5
2.6.3	Synchronizing Coupling .....	5
2.7	Lubrication .....	5
<b>3.</b>	<b>Function Tests without Load .....</b>	<b>6</b>
3.1	Controls before Connection of the Machine.....	6
3.2	Controls after Connection with empty Machine .....	6
3.3	Discharge Door or Discharge Flap(s).....	7
3.3.1	Discharge Door/ Flap Operation, Pneumatic .....	7
3.3.2	Discharge Door/ Flap Operation, Hydraulic .....	7
3.4	Central Lubrication .....	8
3.5	Hydraulic Couplings .....	8
3.6	Electric Switch Gears .....	8
<b>4.</b>	<b>Commissioning and Continuous Operation .....</b>	<b>9</b>
4.1	Break-in Regulations for slip-on Gear Units.....	9
4.2	Break-in Regulations before Commissioning the Mixer, after change of Trough Lining .....	9
4.3	Mixer Feeding.....	9
4.3.1	General Instructions.....	9
4.3.2	Correct feeding .....	10
4.3.3	Sequence of feeding .....	10
4.4	Discharge of Mixer.....	11
4.4.1	Discharge into Truck Mixers.....	11
4.4.2	Discharge on to Trucks.....	11
4.5	Continuous Operation .....	12
4.6	Replacement Gear Units.....	12
4.7	Temperature check on Hydraulic Aggregate .....	12
4.8	Mixing Operation.....	12
4.8.1	Automatic Operation .....	12
4.8.2	Manual Operation .....	13
4.8.3	Stopping the Mixer .....	13
4.9	Extraordinary Operating Conditions .....	14





# Commissioning and Operation

# Operating Instructions

- 4.9.1 *Extended Mixing Time*.....14
- 4.9.2 *Operation in Winter* .....14
- 4.9.3 *Heavy-Load Starts with full Mixer* .....14
- 4.9.4 *Heavy-Load Start with Overfilled Trough (Emergency Start)*.....14
- 4.9.5 *Emergency Standstill during Mixing Operation* .....15
- 4.9.6 *Mechanical Defect* .....15
- 4.9.7 *Power Failure - Manual Opening of Discharge Door*.....15
- 4.9.8 *Actions prior to and after Extended Standstill* .....16
- 5. *Failures and Malfunctions*.....17
- 5.1 *Safety and Protective Devices* .....17
- 5.2 *Trouble Shooting in case of anomalous Operating Performance*.....18



# Twin-Shaft Batch Mixer

# 1. General Instructions



- ▶ **NOTE!**  
For safety instructions and safety requirements, see
  - > Group: User information
  - > Group: General safety instructions
- ▶ Start-up is understood to mean all operating statuses in which a machine is to be used for the first time or re-used after a prolonged break; also see group: Delivery and Intermediate Storage.
- ▶ Initial start-up plays a crucial part in ensuring optimum machine/system operation.



- ▶ **NOTE!**  
Due to the many different influencing factors that need to be taken into consideration, it is recommended to use the machine manufacturer's skilled personnel to start up the machine. This is not only advisable for warranty reasons but also beneficial from the aspect of the professional advice given and checks performed:
  - Identification of assembly damage and errors made in setting up the machine
  - Observation of control instructions and measures during start-up
  - Additional advice on operating the machine (starting-up, feeding, mixing, discharging, etc.)
- ▶ Observe warning signs on the machine!



- ▶ **DANGER!**  
Shut down the machine immediately if:
  - > severe vibration occurs
  - > serious safety deficiencies are identified
  - > hazards occurs as a result of hurled-out material
  - > critical operating statuses, e.g. resulting from overload, are to be anticipated



- ▶ **ATTENTION!**  
If the emergency off switch is actuated, first:
  - > identify the cause
  - > remedy the cause
 before putting the machine back into operation.
  - 
  - ▶ Execute start-up control measures prior to
    - initial start-up,
    - re-use after prolonged shutdown (winter break or repair work)
    -



- ▶ **ATTENTION!**  
Only commence control measures in/on machine and only remove guards once:
  - > repair switch has been set to "Off" ("Aus") and locked,
  - > key is kept in a safe place protected from unauthorised access,
  - > "Maintenance work" ("Instandhaltungsarbeiten") sign is attached to the repair switch.

## 2. Checks prior to Starting

### 2.1 Erection of the Mixer

- ▶ For assembly and connection of the machine refer to group: Assembly and Electric Connection.

### 2.2 Screw Connections

- ▶ All screws at the mixing trough, mixing tools, mixer drive and discharge door/flap, etc. must be checked for tight fit and tightened if necessary! For screw tightening moments refer to Technical Documentation.

### 2.3 Mixing Trough

- ▶ Check:
  - horizontal alignment of the casing
  - distortion of mixing trough by measuring the radial displacement on the synchronizing coupling, refer to group: Maintenance and Inspection.
  - tight connection of input and outlet components (e.g. trough cover)
  - correct and safe installation of all feed and discharge devices
  - correct seating of wear lining so that mixing plates cannot get caught
  - if all rotating and moved parts (e.g. V-belt drive) have protective devices installed
  - if all doors and covers are closed and locking screws, quick acting closures, resp., are a tight and safe fit
  - correct installation of safety limit switches and safety locking switches on the maintenance doors
  - all screw connections, screw tightening moments: refer to Technical Documentation
  - weld seams (visual crack control)

### 2.4 Discharge Door / Discharge Flap

- ▶ Correct removal of maintenance and transport safety devices off the discharge door /flap(s), refer to group: Assembly and Electric Connection.

### 2.5 Mixing Tools

- ▶ Check:
  - if mixing tools are correctly fixed
  - gap width of blade outer edges to the mixing trough (approx. 3 mm)
  - if mixing shaft if rotating freely



## 2.6 Drive

### 2.6.1 V-Belt Drive

▶ **NOTE!**

For V-belt tension and screw tightening torques, see Technical Documents

- Correct seating and alignment of V-belts between drive pulley and driven pulley
- Tight fit of the Taper-Lock Collets, the end disk of the V-belt pulleys, resp., refer to Technical Documentation: Screw Tightening Moments
- **Guards** of V-belt drive(s) and synchronizing coupling for proper attachment and condition.



▶ **ATTENTION!**

V-belts under insufficient tension may present a fire hazard!



### 2.6.2 Motor

▶ **NOTE!**

- > Remove motor guard, see Technical Documents: Three-phase motor
- > Motor connected loads
- > Direction of rotation, see group: Assembly and Electrical Connection
- > Motors with re-greasing facility: as a precautionary measure, both bearings should be re-greased immediately after start-up while motor is running
- > For re-use after prolonged break, see group: Delivery and Intermediate Storage

### 2.6.3 Synchronizing Coupling

- ▶ For alignment, see group: Assembly and Electrical Connection and group: Service and Inspection.



## 2.7 Lubrication

▶ Check:

- Oil level in the gearboxes with stopped mixer
  - oil level till the center of the sight glass (straight bevel gear)
  - oil level till approx. 20 mm below the upper edge of the overflow connection (worm gear)
- leakage on all hose and line connections for oil, grease and compressed air supply, retighten if necessary
- oil level in the oil tank (hydraulic aggregate)
- the oil level must reach the center of the sight glass
- grease level in the grease tank (lube pump)
- the tank must be filled completely

## 3. Function Tests without Load



### 3.1 Controls before Connection of the Machine

- ▶ **ATTENTION!**  
Make sure that:
  - > no parts may get into the machine
  - > personal cannot be endangered by switching on the machine!
- ▶ Switch off **material input**.
- ▶ Machine empty and not under load.
  - It must be possible to turn V-belt drive freely by hand.

### 3.2 Controls after Connection with empty Machine

- ▶ **No-load operation:** 20 - 30 min.
- ▶ **Switch-over time** from star to triangle: 2.5 - 3 sec.  
Refer to group: Erection and Electric Connection

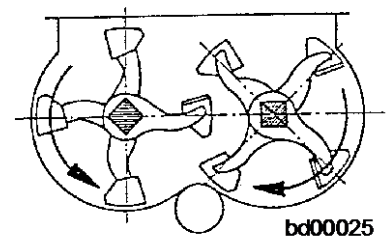

- ▶ **Note the sense of rotation of the mixing shafts**  
Refer to group: Assembly and electrical connection
- ▶ **Unbalance of Mixing Shafts**
- ▶ remarkable **Running Noise** of
  - motor, gearbox, bearings,
  - mixing tools

Remark:  
A swiveling running noise in the rhythm of the mixing shaft speed (overrunning noise) is harmless. Reason: unbalance of the mixing tools.
- ▶ **Tightness** of all hose connections
- ▶ Function and adjustment of all **Control Units** on the mixer (emergency switch, limit switch, locking unit, ...)
- ▶ **Emergency Switch**  
For safety favorable installation and function



### 3.3 **Discharge Door or Discharge Flap(s)**

▶ **DANGER!**

When performing adjustment work at the discharge door or discharge flap operation make sure that nobody is inside the mixing trough.

- ▶ Functional check of discharge door /flap position
  - final positions "open" and "closed"
  - intermediate positions "1/2 open" or "1/3 open" and "2/3 open"
- ▶ Reset limit switches, if necessary.  
For contactless inductive proximity switches the correct switching distance is of approx. 5-7 mm.



#### 3.3.1 **Discharge Door/ Flap Operation, Pneumatic**

▶ **DANGER!**

When performing adjustment work at the discharge door or discharge flap operation make sure that nobody is inside the mixing trough.

- ▶ **Air pressure:** 8 bars required.
- ▶ **Check of Tightness**  
on all hose and line connections, e.g. apply soapy water on the connections.
- ▶ **Adjust Maintenance Unit**  
it comprises: water separator, pressure governor and oil atomizer and it will supply prepared, i.e. dewatered and oiled compressed air for the pneumatic cylinders, refer to group: Maintenance and Inspection.
- ▶ **Pneumatic Cylinders**
  - check function by opening and closing them several times.
  - if necessary, readjust final damping.
  - refer to group: Maintenance and Inspection.

#### 3.3.2 **Discharge Door/ Flap Operation, Hydraulic**



▶ **DANGER!**

When performing adjustment work at the discharge door or discharge flap operation make sure that nobody is inside the mixing trough.



▶ **ATTENTION!**

Check and adjust function of hydraulic unit, refer to Technical Documentation



### 3.4 **Central Lubrication**

- ▶ Installation and functional test as per design (grease or oil/air lubrication) refer to Technical Documentation.
- ▶ Check grease outlet on axial face seal in mixing trough.
- ▶ Check tightness on all hose and line connections.

### 3.5 **Hydraulic Couplings**

- ▶ Check **Performance** during mixing operation.  
If an increased temperature (approx. 70°C, 158°F, resp.) is found during continuous operation, check the oil filling.
- ▶ Refer to: Technical Documents



### 3.6 **Electric Switch Gears**

- ▶ Functional testing and adjustment of all switchgears on the mixer.
- ▶ Check function of **Safety Limit Switches and Locking Units** at the access hatches of the trough cover. For instructions on the functional test refer to Group: Maintenance and Inspection.
- ▶ Check function of **Repair and Emergency Switches** on the mixer.
- ▶ Setting of **Over speed Monitor** and check proper functioning.
  - The mixer drive must be switched off, if speed drops to 10-15% below idling speed.
  - Start bridging is to be set to 10 seconds.
  - Functional test: Slowly turn up the knob for precise impulse adjustment at idling. When reaching the idling speed the mixer motor will be switched off. The switch-off point under load is 10-15 % below the idling speed.
  - For explanations on the over speed monitor refer to Technical Documentation.
- ▶ **Voltage Control** (cos -monitor) for mixer motor. The value to be set corresponds to the power factor (cos) of the motor in no-load operation.

# 4. Commissioning and Continuous Operation

## 4.1 Break-in Regulations for slip-on Gear Units

- ▶ **No-Load Operation:** 30 minutes (without mix)
- ▶ **Break-In Rhythm**  
1st batch filling = approx. 1/2 nominal filling 60 sec.  
2nd batch filling = approx. 1/2 nominal filling 60 sec.  
3rd filling = nominal filling 60 sec.

This break-in rhythm must be repeated 20 times.

## 4.2 Break-in Regulations before Commissioning the Mixer, after change of Trough Lining



- ▶ **ATTENTION!**  
The first **10 mixing operations** shall be run with **very liquid** concrete consistencies and a particle size of max. 4 mm. Thus; the tiles of the trough lining are backfilled with concrete laitance, which will give additionally support to the tiles after hardening.  
After this start-up procedure clean the mixer carefully to not rinse out the backfilling of the trough lining and allow it to harden

## 4.3 Mixer Feeding

### 4.3.1 General Instructions



- ▶ **ATTENTION!**  
Before starting, make sure that the mixer and feeding units are free from foreign **matters** which could cause a blockade of the mixing tools.
- ▶ **NOTE!**  
Keep the data agreed by the Technical Specification and the Order Acknowledgement:



This concerns in particular the following points:

- throughput
  - type of feed material
  - size of feed material
  - drive power
- ▶ Deviations only after agreement with the machine manufacturer!
    - For proper feeding and feeding sequence refer to Technical Documentation.
  - ▶ Insert **Material feeding** only if mixing tools have reached the operating speed
  - ▶ **Feeding unit**  
In regular intervals, special during breaking-in, check for obstruction.



#### 4.3.2 Correct feeding

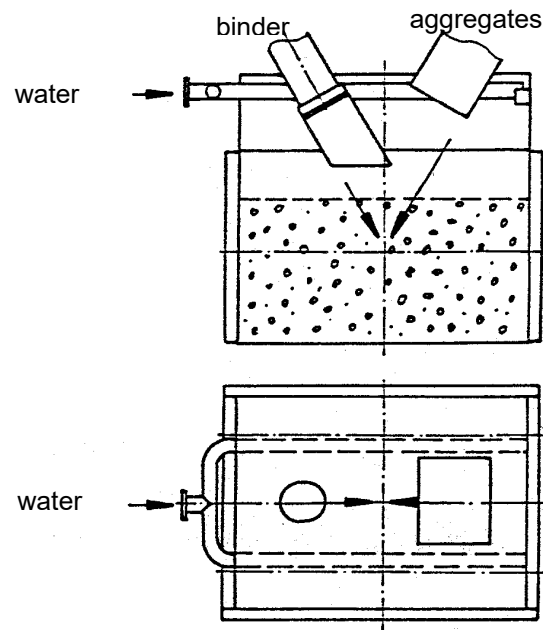

- ▶ Position and direction of binder and aggregate inlets are decisive for short mixing times and good mixing. They, moreover, will avoid deposits on the mixing tools.  
Recommended arrangement of the feeding devices refer to Technical Documents, installation drawing
- ▶ The water spraying system consists in an U-shaped pipe with rows of holes and nozzles. Liquid admixtures should be added to the water.
- ▶ The rubber tube fixed on the cement inlet must be cut parallel to the mixing shaft so that it will be slightly touched by the mixing blades at any revolution (self-cleaning).

#### 4.3.3 Sequence of feeding

- ▶ Feeding of the additive scale and intermediate vessel must be effected such that during discharge the coarser fractions enter the mixer at first followed by the finer fractions (sands)
- ▶ Feeding of the mixer with aggregates, binders and water must be made in a determined and timed sequence.
- ▶ The Twin-Shaft Batch Mixer normally does not require dry mixing times. The water will generally be called off together with the aggregates or 1-2 seconds later.
- ▶ It is important that the aggregates are advanced against the binder. When calling off the binder 80-90 % of the aggregates must already be in the mixing trough.

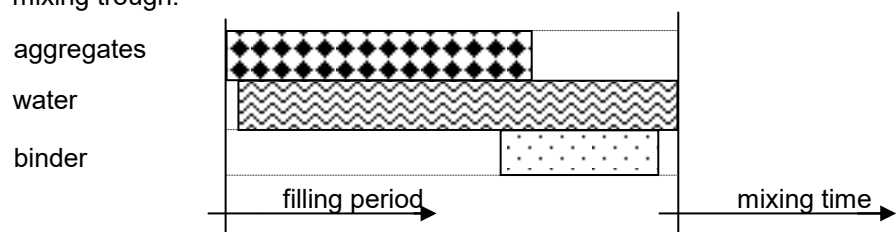

#### 4.4 Discharge of Mixer



- ▶ The discharge of the mixer is made through a discharge hopper on to the transport vehicles or receiving points

▶ **NOTE!**

It must be assured that with nominal filling capacity and stiff consistency of the mix approx. 95-96 % of the mixing trough is emptied. If this is not the case the discharge time must be extended.

Instructions on discharge door and discharge flap actuation for various discharge situations refer to Technical Instructions

##### 4.4.1 Discharge into Truck Mixers

- a) On Twin-Shaft Batch Mixers with "standard discharge door or discharge flap" an intermediate position "1/2 open" is provided, as a rule. For exception, however, two intermediate positions "1/3 open" and "2/3 open" may be provided.

- b) On Twin-Shaft Batch Mixers with "large discharge door" two intermediate positions "1/2 open" and "2/3 open" are provided, as a rule.



▶ **NOTE!**

Control of these intermediate positions, and their holding times, should be adapted to the receiving capacity of the truck mixer, and to the consistency

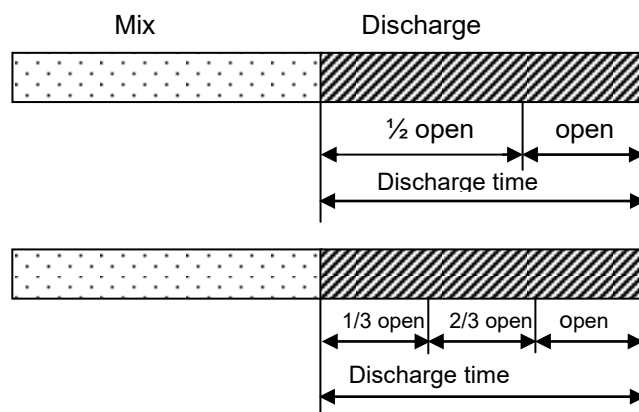

##### 4.4.2 Discharge on to Trucks

- ▶ On Twin-Shaft Batch Mixers with "standard and large discharge doors" discharge will directly take place through the discharge opening "open"; intermediate positions are not used.



#### 4.5 *Continuous Operation*

- ▶ Upon termination of the break-in rhythm, start of continuous operation with nominal filling, refer to Technical Specification.
- ▶ Temperature check of slip-on gear units
  - The external temperature on the slip-on gear units must be measured by contact thermometer in the input shaft area during the first 10 full load operating hours after commissioning.
- ▶ **ACHTUNG!** Depending on the load, normal gear temperatures are in continuous operation approx. 25°C to 45°C (77°F to 113°F) higher than the respective ambient temperature; however the maximum temperature of 90°C (194°F) must not be exceeded. If higher temperatures are found, reduce the batch filling to half the nominal filling and inform the mixer manufacturer immediately.

#### 4.6 *Replacement Gear Units*

- ▶ When the mixer drive is equipped with a new slip-on gear unit, the break-in regulations must be repeated.



#### 4.7 *Temperature check on Hydraulic Aggregate*

- ▶ refer to Technical Documentation: Operating Instructions for Hydraulic Aggregate

#### 4.8 *Mixing Operation*

##### 4.8.1 *Automatic Operation*

- ▶ The mixer drive runs continuously, only for pauses it is switched-off by hand.
- ▶ The automatic control function and functional control of a mixing cycle comprises:
  - feeding
  - mixing
  - discharge
- ▶ The mix components for each mixing batch will be prepared automatically.
- ▶ The first mixing cycle begins with time lag after switching the mixer on with control functions "Discharge door/ flap closed", "Aggregate scale open".
- ▶ All other control functions for calling water and binder, for mixing and discharge time, run off program controlled.

- ▶ The first mixing cycle will be completed with the function message "Discharge door/flap closed". For several batches in succession, the cycles are automatically controlled. They begin each time when electrical interlocking is released by the message that all weigh- batchers are full and the discharge door/flap is closed.

#### 4.8.2 *Manual Operation*

- ▶ The mix components for each mixing batch can be provided either by automatic or manual actuation.
- ▶ After switching on the mixer the mixing cycle begins with the control function "Discharge door/ flap closed", "Aggregate scale open".
- ▶ All other control functions for calling water and binder, for mixing and discharge time, run off program controlled.
- ▶ The mixing cycle will be completed with the function message "Discharge door/flap closed".

#### 4.8.3 *Stopping the Mixer*

- ▶ Stopping is made as follows:
  - stop weighing of mix components.
  - open discharge door/ flap and empty the mixing trough with mixing tools running.
  - cut off mixer drive, central lubrication and hydraulic unit.
  - prior to short production breaks (45-60 min.) clean the interior of the trough and discharge door/ flap with a high-pressure water jet, if the mix requires this. Thus, deposits of mix may far-reaching be avoided.
  - prior to extended interruption and at shift end, clean the mixer - refer to group: Maintenance and Inspection.
  - lubricate inner axial face seal.
- ▶ **DANGER!**
  - > Check V-belt pre-tension, see group: Service and Inspection;
  - > if necessary, re-tighten, see Technical Documents.



#### **V-belt slippage presents risk of fire and poisoning!**

For further notes refer to group: Maintenance and Inspection

## 4.9 Extraordinary Operating Conditions

### 4.9.1 Extended Mixing Time

- ▶ Mixing times of more than 2 minutes mean:
  - increased wear
  - additional thermal stress on the drive, particularly in conjunction with stiff mix consistency.

### 4.9.2 Operation in Winter



- ▶ **NOTE!**
  - > At ambient temperatures of approx. - 10°C (14°F), run mixer at no load for a minimum of 30 minutes prior to commencing work.
  - > At even lower temperatures, gear units and motors should be heated from outside with hot air from a heater blower.

### 4.9.3 Heavy-Load Starts with full Mixer



- ▶ **NOTE!**  
**Star-delta start:**
  - > Mixer drive **with** hydraulic coupling: When mixer is filled with rated charge, high-inertia starting always takes place in star-delta mode.
  - > Switchover from star to delta in 2.5 to 3 seconds.



- ▶ **NOTE!**  
**Direct start-up:**
  - > Mixer drive **without** hydraulic coupling:
  - > When mixer is filled with rated charge, high-inertia starting always takes place in star-delta mode (direct activation).

### 4.9.4 Heavy-Load Start with Overfilled Trough (Emergency Start)



- ▶ **NOTE!**  
With overfilling by a second batch due to control failure
  - > open discharge door or flap
  - > empty the mixing trough and, if required, rinse with water.
- ▶ Clearing of the mixing trough may be accelerated by jerkily starting of the mixer drive, but only when both mixing shafts have become visible. However, observe that the type of heavy-load start depends on the design of the mixer drive.
- ▶ If the mixer drive does not draw through for clearing the mixing trough,
  - the duration of switching on the motors must not exceed 2 seconds
  - the frequency of switching-on is limited to max. 3 times one after the other.

#### 4.9.5 *Emergency Standstill during Mixing Operation*



▶ **ATTENTION!**

If the Emergency Off switch is actuated, first

- > identify the cause,
- > remedy the cause.

Before putting the machine back into operation!

- ▶ Normally, this means that the mixer will stop while filled with mixing material.



▶ **NOTE!**

If, within a short period of time (appr. 10 min.), e.g. with concrete mix, the cause of the standstill cannot be eliminated, the discharge door/flap must immediately be opened and the mix be discharged

#### 4.9.6 *Mechanical Defect*

- ▶ Knock out the bolt of the fork head connection discharge door/flap - pneumatic/hydraulic cylinder.
- ▶ Swing out sideways the pneumatic/ hydraulic cylinder.
- ▶ Open discharge door/flap by means of a bar (lever action).



▶ **DANGER!**

**Discharge door/flap could open suddenly**

#### 4.9.7 *Power Failure - Manual Opening of Discharge Door*



▶ **NOTE!**

In case of a power failure manual opening has to be done according to the existing discharge door operation.

- ▶ Manual opening of the discharge door/flap should be trained before an emergency occurs already; in case of an emergency it will be too late!

▶ **Manual Opening of Discharge Door with Pneumatic Actuation**

- Discharge door/flap can be actuated on one or both sides with pneumatic cylinders, where the compressed air for either side will be controlled by a 5/3 ways solenoid valve.
- Each solenoid valve has two manual emergency controls for switching functions "open" and "close", which will be actuated by turning or pressing.
- Procedure for opening:
  - Turn or press manual emergency actuation "open" on the 5/3 ways solenoid valve. When two valves are provided, both must be actuated simultaneously.
  - The compressed air available in the compressor will be sufficient for actuation.
  - When the trough is empty the manual emergency actuations should be returned to their zero positions.



- ▶ **Manual Opening of Discharge Door with Hydraulic Actuation**
- ▶ refer to Technical Documentation: Operating Instructions for Hydraulic Aggregate



- ▶ **Manual Opening of Discharge Door with Electrical Actuation**
- ▶ **DANGER!**  
**Attention! Isolate the motor and brake from the power supply before starting work, safeguarding them against unintentional power-up!!**
  - Remove the Cover from the Fan-Wheel at the Motor
  - Discharge the Brake of the Motor manually (see Manual Servo-Motor)
  - Revolve the Motor by Hand with the Fan-Wheel, until Discharge Door is opened.
  - When the trough is empty, it must be closed again and everything should be returned to its zero-position
  - **Important!** Don't forget to mount the Cover of the Fan-Wheel at the Motor.

#### **4.9.8 Actions prior to and after Extended Standstill**

- ▶ Actions prior to extended standstill  
Refer to group: Delivery and Intermediate Storage
- ▶ Commissioning after extended standstill  
Refer to group: Starting and Operation

# 5. *Failures and Malfunctions*



## 5.1 *Safety and Protective Devices*

▶ **NOTE!**

For safety instructions and safety requirements, see

- > Group: User information
- > Group: General safety instructions

▶ **DANGER!**

- > **Dismounted protective devices constitute a considerable safety hazard; they must be re-installed after termination of work and before starting the machine.**
- > **Safety devices must not be dismantled for troubleshooting during machine operation.**
- > **To find the causes of failures with running machine, the existing safety and protective devices must not be removed**



## 5.2 Trouble Shooting in case of anomalous Operating Performance

Symptom	Reason	Action
Running noise on motor	<ul style="list-style-type: none"> <li>- Bearing defective</li> <li>- Fan blade grazes at fan hood</li> </ul>	<ul style="list-style-type: none"> <li>- Replace bearing</li> <li>- Align or replace deformed fan blade</li> </ul>
Mixer does not start when empty (often during commissioning)	<ul style="list-style-type: none"> <li>- Motors are running in opposite directions in case of two-motor drive</li> <li>- Hydraulic clutch without oil</li> </ul>	<ul style="list-style-type: none"> <li>- Change sense of rotation of one motor (observe correct rotation of mixing shafts!)</li> <li>- Refill oil</li> </ul>
Periodic running noise on gear units when idling	<ul style="list-style-type: none"> <li>- Overriding noise in the gearing, caused by unbalance of the mixing tools</li> </ul>	<ul style="list-style-type: none"> <li>- None - harmless</li> </ul>
Running noise on gear units when idling	<ul style="list-style-type: none"> <li>- Bearing damage or beginning gearing damage</li> </ul>	<ul style="list-style-type: none"> <li>- Contact BHS</li> </ul>
Running noise on hydraulic coupling(s) filling	<ul style="list-style-type: none"> <li>- Bearing damage</li> <li>- Too much oil</li> </ul>	<ul style="list-style-type: none"> <li>- Replace bearing</li> <li>- Check oil</li> </ul>
Unsteady running of mixer drive	<ul style="list-style-type: none"> <li>- Bearing damage of hydraulic coupling</li> <li>- Cement sticking to coupling and V-belt pulley</li> </ul>	<ul style="list-style-type: none"> <li>- Replace bearing</li> <li>- Clean hydraulic coupling and V-belt pulley</li> </ul>
Discharge door/flap closes abruptly screw	<ul style="list-style-type: none"> <li>- Damping on cylinders too soft.</li> <li>- Throttle back valve opened too far</li> </ul>	<ul style="list-style-type: none"> <li>- Adjust damping harder. Turn adjusting to the right.</li> <li>- Reset.</li> </ul>
Discharge door/flap jams when closing	<ul style="list-style-type: none"> <li>- Sealing gap too big</li> <li>- Damping on cylinders too hard</li> <li>- Water in the pneumatic cylinder.</li> <li>- Air in the hydraulic cylinder.</li> </ul>	<ul style="list-style-type: none"> <li>- Reset sealing ledges.</li> <li>- Adjust damping softer. Turn adjusting screw to the left.</li> <li>- Dewater compressed air.</li> <li>- Remove water from cylinder.</li> <li>- De-aerate pipes.</li> </ul>
Discharge door (pneumatic) does not open	<ul style="list-style-type: none"> <li>- Stones jammed between discharge door ledge and drum protection</li> <li>- Pressure of pneumatic supply line below 8 bar</li> </ul>	<p> <b>Attention:</b> Depressurize pneumatic cylinders</p> <ul style="list-style-type: none"> <li>- Release screws at pedestal bearings of discharge door drum and lower discharge door by approx. 2 mm.</li> <li>- Increase pressure of the pneumatic line</li> </ul>
Intermediate positions for discharge door/flap overrun	<ul style="list-style-type: none"> <li>- Cylinders, valves or line connections are leaking.</li> <li>- Limit switch defective.</li> </ul>	<ul style="list-style-type: none"> <li>- Replace cylinder seals and valves.</li> <li>- Tighten connections or replace sealing rings.</li> <li>- Replace limit switch.</li> </ul>

Symptom	Reason	Action
<b>Mixer stops</b>	<ul style="list-style-type: none"> <li>- V-belt tension insufficient.</li> <li>- Not enough oil in hydraulic coupling</li> <li>- Electrical reason.</li> <li>- Wrong feeding of mixer resp. proportioning</li> </ul>	<ul style="list-style-type: none"> <li>- Re-tension V-belts.</li> <li>- Check oil filling.</li> <li>- Check electric supply, fuses, voltage, etc.</li> <li>- Check feeding of mixer and proportioning quantity</li> </ul>
<b>Formation of deposits on mixing shafts, mixing tools and trough cover</b>	<ul style="list-style-type: none"> <li>- Wrong feeding of mixer, e.g. cement called too early, water called too late, aggregate and cement inlet not optimal</li> <li>- Cement inlet pipe without rubber hose.</li> </ul>	<ul style="list-style-type: none"> <li>- Set cement and aggregate call correctly.</li> <li>- Maybe change inlet situation.</li> <li>- Mount rubber hose.</li> </ul>
<b>Clogging in the discharge hopper</b>	<ul style="list-style-type: none"> <li>- First intermediate discharge position (e.g. for stiff concrete) too big (capacity of truck mixer insufficient)</li> </ul>	<ul style="list-style-type: none"> <li>- Reduce first intermediate discharge position.</li> </ul>
<b>Loud mixing noise</b>	<ul style="list-style-type: none"> <li>- Blade gap too big</li> </ul>	<ul style="list-style-type: none"> <li>- Readjust lateral and central blades</li> </ul>
<b>Excessive wear on mixing and wearing tools</b>	<ul style="list-style-type: none"> <li>- Blade gap too big.</li> <li>- Sealing gap on discharge door/flap too large.</li> <li>- Mixing time too long.</li> <li>- Broken and abrasive additives.</li> </ul>	<ul style="list-style-type: none"> <li>- Readjust lateral and central blades.</li> <li>- Reset sealing ledges.</li> <li>- Reduce mixing time.</li> <li>- Optimize feeding and discharge in order reduce time</li> </ul>
<b>Cement slurry leaking outside at mixing shaft sealing</b>	<ul style="list-style-type: none"> <li>- Axial face seal damaged due to insufficient lubrication</li> </ul>	<ul style="list-style-type: none"> <li>- Replace axial face seal</li> </ul>
<b>Hydraulic clutch drains oil</b>	<ul style="list-style-type: none"> <li>- Overload of coupling due to surcharge or starting with full mixer</li> <li>- Increased slipping because of insufficient oil filling</li> </ul>	<ul style="list-style-type: none"> <li>- Open discharge door and remove material (refer to starting under load with surcharged mixer)</li> <li>- Check oil filling</li> </ul>



## Servicing and Inspection

# Operating Instructions

- 1. *General Instructions* .....2
- 2. *Service and Inspection Plan* .....4



## Twin-Shaft Batch Mixer

# 1. General Instructions



- ▶ **NOTE!**  
For safety instructions and safety requirements, see
  - > Group: User information
  - > Group: General safety instructions



- ▶ **ATTENTION!**  
Only commence checking and maintenance work and only remove cover doors, guards and other machine parts once:
  - > Repair switch has been set to “Off” (“Aus”) and locked
  - > key is kept in a safe place protected from unauthorised access,
  - > “ Maintenance work“ (“Instandhaltungsarbeiten“ ) sign is attached to the repair switch
  - > stopping times have been observed for moving machine parts.



- ▶ **DANGER!**  
Check machine before switching on and eliminate sources of danger
  - > Guards must be in place
  - > Housing closed and locked
  - > Remove tools from inside and around the machine
  - > Service work hazards in machine environment and from the machines insalled in the process chain



- ▶ **NOTE!**  
Inadequate or poor servicing and maintenance will increase susceptibility to malfunctions and repair and reduce warranty cover.



- ▶ **NOTE!**  
The following service and maintenance schedule applies to:
  - > single-shift operation
  - > treatment of mixing materials that cause normal wear



- ▶ **NOTE!**  
The user must define or amend the service and maintenance schedule to suit operating conditions.

Service and maintenance schedule may diverge from the following schedule if:

- > highly abrasive feeding material is processed
- > the machine is used in adverse climatic contitions
- > the machine is operated round the clock



- ▶ **ATTENTION!**  
Electrical installation, control cabinets, motors, gears, auxiliary units such as centralized lubrication, drives, hydraulic and pneumatic installations may not be cleaned by pressure washers.



- ▶ **NOTE!**  
Once removed, replace fixing elements, such as screws, nuts, bolts, with new ones of the same quality (material, strength) and design.

For screw connection torque values, see Technical Documents



- ▶ **NOTE!**  
It is imperative, even after start-up, to continue monitoring all screw connections on the mixer for proper seating, and to re-tighten them to the appropriate torque if necessary. In particular, check all moving parts, e. g. drive, mixing mechanism

Observe warning signs on the machine!



- ▶ **DANGER!**  
**Install a safeguard against rotation!**  
**If for maintenance operations personnel is in the mixing space, all mixing shafts and the discharge door/discharge flap must be safeguarded against rotation:**
  - > place wedges between the mixing blades and trough walls or
  - > put one wedge on each side of the V-belt pulley on the gearbox to block the V-belt drive (only where synchronous coupling is installed)
  - > install discharge door/discharge flap safety device, refer to group: Maintenance
  - > remove anti rotation element after completing the service work

## 2. Service and Inspection Plan

Checking period hours		Item	Subassembly	Maintenance unit	Scope of control or maintenance
from h	to h				
8	10		Drive	V-belts (new)	<ul style="list-style-type: none"> <li>- Check V-belt tension see Technical Documentation</li> <li>- Short inspection algorithm and retightening until there are no more setting phenomena</li> </ul>
8	10		Hydraulic plant	Aggregate	- see Technical Documentation
8	10		Mixer	Trough interior Mixing tools Discharge door/flap Trough cover	<ul style="list-style-type: none"> <li>- Cleaning of mixing trough in dependence of mix properties</li> <li>- Short intermediate Cleaning is more efficient and cheaper than one cleaning at shift end.</li> <li>- Cleaning with press-water jet (50-80 bar)</li> <li>- At cleaning open and close discharge door/flap several times.</li> <li>- With wet mixes after cleaning the trough interior, mixing tools, discharge door/flap, trough cover spray with concrete solvent.</li> <li>- Electric devices (motor, solenoid valve, limit switch, pumps, etc.) do not pressure clean with steam or water jet.</li> <li>- Let V-belts dry.</li> </ul> <p style="text-align: center;"> <b>NOTE</b> Only fill floating ring seal with grease after having cleaned the interior of the trough</p>
8	10		Central lubrication grease	Pump Control Pipings	<ul style="list-style-type: none"> <li>- Functional test</li> <li>- Tightness</li> <li>- see Technical Documentation</li> </ul>
40	50		Drive	Gearbox	<ul style="list-style-type: none"> <li>- Gearbox temperatures measured with contact thermometer at drive shaft: <ul style="list-style-type: none"> <li>· 25 °C - 45 °C higher than ambiance</li> <li>· maximum temperature 90 °C</li> </ul> </li> </ul>
40	50		Drive	Motor Gearbox Coupling	<ul style="list-style-type: none"> <li>- Noise</li> <li>- Unbalance</li> <li>- Wear</li> <li>- Correct fixing</li> <li>- Grease, oil leakage</li> <li>- Temperature</li> <li>- Clean cooling ribs</li> <li>- Further indications see Technical Documentation</li> </ul>

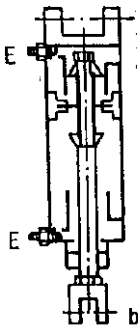
Checking period hours		Item	Subassembly	Maintenance unit	Scope of control or maintenance
from h	to h				
40	50		Drive	V-belts	- For prolonged use check tension see Technical Documentation. - Replace V-belts not individually, but in sets only (assorted lengths).
40	50		Discharge door/flap		- Functional test
40	50		Discharge door/flap operation	Cylinders	- Check: <ul style="list-style-type: none"> <li>· Tightness</li> <li>· Correct fixing</li> </ul> - Functional test <ul style="list-style-type: none"> <li>· Open and close several times</li> <li>· If end position is jerkily reached end damping „E“ of the cylinders is set too hard. Turn the setscrew left to set it softer.</li> <li>· If the end of a stroke is indicated by a metallic blow end damping „E“ must be harder. Turn the setscrew right to set it harder.</li> </ul> - After having adjusted the damping, tighten the counter nut of the setscrews. <div style="text-align: right;">  <p>bd00015</p> </div>
40	50		Discharge door/flap	Pedestal bearings	- Clean outside
40	50		Discharge door/flap operation	Limit switch solenoid valve	- Functional test - Switching position - Eliminate defects
40	50		Discharge door/flap	Hydraulic plant	- see Technical Documentation
40	50		Discharge door/flap	Hydraulic cylinder	- Check: <ul style="list-style-type: none"> <li>· Function</li> <li>· Tightness</li> <li>· Correct fixing</li> <li>· Open and close several times</li> </ul>
40	50		Mixer	Feeding Discharge	- Feeding sequence - Trough discharge (95-96 %)

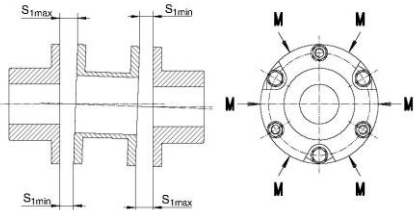
Checking period hours		Item	Subassembly	Maintenance unit	Scope of control or maintenance
from h	to h				
40	50		Mixing tools	Mixing blade Mixing arm Mixing shaft	<ul style="list-style-type: none"> <li>- Remove cement adherences.</li> <li>- Check wear condition, see Technical Documentation</li> <li>- Replace used parts, if necessary</li> <li>- Tight fit of mixing arms on shaft (screw tightening torque see Technical Documentation)</li> <li>- Tight fit of mixing blades on arms.</li> <li>- Gap between mixing blades and trough wall approx. 5 mm.</li> </ul> Adjust mixing blades, if necessary
40	50		Mixing trough	Wearing tiles Dust cover Wearing ring	<ul style="list-style-type: none"> <li>- Check wear condition, replace if necessary.</li> <li>- Parts items see spare parts list</li> </ul>
40	50		Trough cover	Safety limit switch	- Functional test: With open access hatches of the trough cover it must not be possible to start the mixer.
40	50		Trough cover	Safety locking switch	- Functional test: This switch locks the access hatches of the trough cover while the mixer is running. Locking ends only with the electric signal „mixer switched off“.
40	50		Trough cover		<ul style="list-style-type: none"> <li>- Wear</li> <li>- Correct fixing of feed devices.</li> </ul>
200	300		Mixer-Drive	Arpex-Multi-Disc-Clutch	<ul style="list-style-type: none"> <li>- Check discs for cracks. If there are any cracks discoverable, the disc-pack must be replaced <u>immediately</u>.</li> <li>- Afterwards check the alignment.</li> <li>- <b>ATTENTION!</b> Before decoupling the Multi-Disc Clutch, you have to secure the Mixing-Shafts to avoid turning out of Position.. The correct Position of the Mixing-Mechanism is marked at the End of the Mixing-Shafts.</li> <li>- Check the correct Position of the Mixing-Mechanism before and afterwards of the Replacement.</li> <li>- Recheck interspace <math>S_{min}</math> 14,5mm, <math>S_{max}</math> 15,5mm at the positions M!</li> <li>- In addition please consider the mounting-instructions for the Arpex-Clutch.</li> </ul> <div style="text-align: center;">  </div> <div style="text-align: center;">  </div>

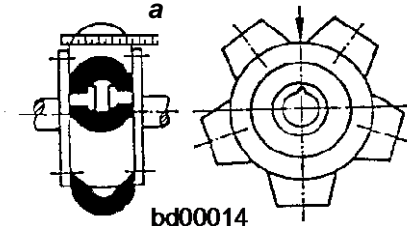

Checking period hours		Item	Subassembly	Maintenance unit	Scope of control or maintenance
from h	to h				
200	300		Drive	Synchronous coupling Typ: MCF	<ul style="list-style-type: none"> <li>- Check rubber elements for cracks.</li> <li>- If cracks are found, replace rubber elements <u>immediately</u>.</li> <li>- Check alignment.</li> <li>- <b>ATTENTION!</b> Before uncoupling the synchronous coupling secure mixing shafts against twisting. The correct position of mixing tools is marked on the shaft ends. Before and after coupling check correct mixing tools position.</li> <li>- Check mismatch "a" in two planes with a ruler, max. mismatch <math>\pm 1</math> mm</li> </ul> <div style="text-align: center;">  <p>bd00014</p> </div>
200	300		Drive	Bellows coupling	<ul style="list-style-type: none"> <li>- In case of drives with 4 gears, one side is equipped with a bellows coupling.</li> <li>- Check alignment</li> <li>- <b>ATTENTION!</b> If the coupling on the opposite side is also loosened before decoupling the synchronous coupling, secure mixer spiral against twisting. The right mixer position is identified at the mixer spiral ends. Check the right mixer position before and after coupling.</li> <li>- Check eccentricity "a" with a ruler in two levels, max. misalignment: <math>\pm 1</math> mm</li> </ul>

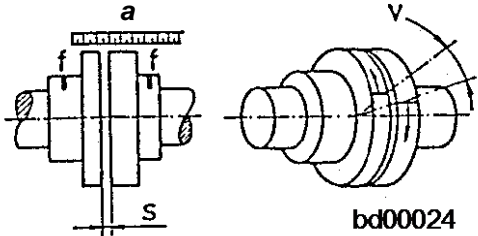
Checking period hours		Item	Subassembly	Maintenance unit	Scope of control or maintenance
from h	to h				
200	300		Drive	Synchronous coupling Type: N-Eupex 	<ul style="list-style-type: none"> <li>- Check circumferential backlash, if it exceeds 3 mm, replace rubber set.</li> <li>- Check alignment.</li> <li>- <b>ATTENTION!</b> Before uncoupling the synchronous coupling secure mixing shafts against twisting. The correct position of mixing tools is marked on the shaft ends. Before and after coupling check correct mixing tools position.</li> <li>· gap: <math>s = 2 - 4</math> mm</li> <li>· check mismatch in two planes with a ruler: <math>a_{\max} = \pm 0,15</math> mm</li> <li>· circum. Backlash: <math>v_{\max} = 3</math> mm</li> <li>· tighten locking screws f.</li> </ul>  <p style="text-align: right;">bd00024</p>
200	300		Dischare door/flap	Sealing gap	<ul style="list-style-type: none"> <li>- Check: <ul style="list-style-type: none"> <li>· Sealing function</li> <li>· Wear</li> </ul> </li> <li>- Readjust sealing, if necessary</li> </ul>
200	300		Mixing trough		<ul style="list-style-type: none"> <li>- Wear check</li> <li>- Deformations</li> <li>- Untighten junctions</li> </ul>
200	300		Protective hoods	Drive V-belt drive Pneumatic/ Hydraulic cylinders	<ul style="list-style-type: none"> <li>- All-round protection of rotating and moved parts against touching</li> <li>- Safe fixing</li> <li>- Cleanness</li> </ul>
1.000	1.500		Hydraulic plant	Return filter Air filter	<ul style="list-style-type: none"> <li>- Check</li> <li>- Change if necessary</li> <li>- see Technical Documentation</li> </ul>
1.500	2.000		Hydraulic plant	Hand pump	<ul style="list-style-type: none"> <li>- Operate</li> </ul>
1.500	2.000		Central grease lubrication	Grease tank	<ul style="list-style-type: none"> <li>- Clean</li> <li>- see Technical Documentation</li> </ul>
4.000	5.000		Drive	Motor	<ul style="list-style-type: none"> <li>- Antifriction bearings to be checked and cleaned by motor specialist</li> <li>- Replace bearings, if necessary.</li> </ul>

## Lubrication

# Operating Instructions

<b>1.</b>	<b><i>General Instructions</i></b> .....	<b>2</b>
<b>2.</b>	<b><i>Types of Lubrication</i></b> .....	<b>3</b>
<b>2.1</b>	<b><i>Manual grease lubrication of all lubrication points</i></b> .....	<b>3</b>
<b>2.2</b>	<b><i>Central lubrication-grease, manual grease lubrication of all lubrication points</i></b> .....	<b>3</b>
<b>2.3</b>	<b><i>Central lubrication- grease with control unit, manual grease lubrication of subordinate lubrication points</i></b> .....	<b>3</b>
<b>2.4</b>	<b><i>Central lubrication-grease with control unit to supply all lubrication points</i></b> .....	<b>3</b>
<b>2.5</b>	<b><i>Central lubrication oil-air with control unit, manual grease lubrication of subordinate lubrication points</i></b> .....	<b>4</b>
<b>2.6</b>	<b><i>Central lubrication-oil-air with control unit, combined with grease pump with control unit to supply all lubrication points</i></b> .....	<b>4</b>
<b>3.</b>	<b><i>Lubrication chart</i></b> .....	<b>5</b>

# 1. General Instructions



- ▶ **NOTE!**  
For safety instructions and safety requirements, see
  - > Group: User information
  - > Group: General safety instructions



- ▶ **NOTE!**  
Inadequate or poor lubrication will increase susceptibility to malfunctions and repair and reduce warranty cover.
- ▶ Specific lubrication charts may deviate from the following chart if:
  - operation is made under unfavourable climatic conditions
  - low-consistency mixtures are processed
  - high-temperature products are mixed
  - the machine works in multi-shift operations
  - if strongly abrasive materials are processed (adjustment of sealing gap)



- ▶ **NOTE!**  
The user has to determine and, if necessary, amend the Lubrication Chart to suit individual operating conditions.
- ▶ Lubrication schedule may deverge from the following schedule if:
  - the machine is used in adverse climatic conditions
  - the machine is operated in several shifts
- ▶ Observe warning signs on the machine
- ▶ Lubricants such as oils and greases must be kept in clean, sealed containers (tins, cans, hobbocks, barrels) to prevent the penetration of dust and humidity and to minimise the effect of oxidation caused by air. They should be stored in a cool, dry place.



- ▶ **NOTE!**  
Lubrication work must be performed after cleaning the mixer since lubricants may otherwise be flushed out or washed off.  
**Hardened mix components at the inner mixing trough seal may cause the destruction of the axial face seal!**



- ▶ **NOTE!**  
For the additional units attached to the machine and maintenance units, such as gear unit, hydraulic coupling, oil/air central lubrication unit, hydraulic system, use the recommended lubricants only, see Technical Documents.



- ▶ **NOTE!**  
Using a central lubrication system shall not release you from carrying out inspections! In case of a machine breakdown the manual lubrication stated in the lubrication chart under item 2.1 refers.
- ▶ When using central lubrication systems make regular checks to verify whether warning signals (e.g. grease tank empty) are shown and transmitted correctly to the control unit

## 2. Types of Lubrication

### 2.1 Manual grease lubrication of all lubrication points

- ▶ All lubrication points are greased by hand.
- ▶ With the new mixer line, the most important lubrication points are combined on two central points.

### 2.2 Central lubrication-grease, manual grease lubrication of all lubrication points

- ▶ to supply grease to the inner sealing chamber of the mixing shaft seal during operation of the mixer!
- ▶ **NOTE!**  
After cleaning the mixer, greasing of these lubricating points must still be effected manually.
- ▶ Use if a particularly high share of low-viscosity concrete types shall be mixed.



### 2.3 Central lubrication- grease with control unit, manual grease lubrication of subordinate lubrication points

- ▶ to supply lubricant to the internal sealing chamber of the mixing shaft seal during operation of the mixer!
- ▶ **NOTE!**  
These lubrication points are greased after cleaning the mixer. The lubrication process is actuated manually through the pump control unit
- ▶ The personnel is relieved from the most time-consuming lubrication process.



### 2.4 Central lubrication-grease with control unit to supply all lubrication points

- ▶ to supply lubricant to all important grease lubrication points during operation of the mixer!
- ▶ Depending on the design, the system may consist of one or two pumps
- ▶ **NOTE!**  
Lubrication of the inner grease chamber after cleaning of the mixer is effected by manual actuation of the lubrication process via the pump control unit.
- ▶ Owing to this system the machine requires very little maintenance in the field of lubricant supply.  
Subject to correct integration of the control unit and maintenance of the system the working reliability of the machine and service life of the parts is increased.



## 2.5 **Central lubrication oil-air with control unit, manual grease lubrication of subordinate lubrication points**



- ▶ to supply the internal sealing chamber of the mixing shaft seal with an oil-air mixture.

- ▶ **NOTE!**

Lubricating the internal sealing chamber after cleaning of the mixer is to be ensured by a slowing down time of the oil-air application to the sealing points.

Slowing down time: approx. 30 min



- ▶ **NOTE!**

The oil filling devices and oil storage tanks must enable an absolutely contamination-free transfer of the oil into the storage vessel.

- ▶ Lubricant consumption is very small as compared to grease lubrication.

## 2.6 **Central lubrication-oil-air with control unit, combined with grease pump with control unit to supply all lubrication points**



- ▶ to supply the internal sealing chamber of the mixing shaft seal with an oil-air mixture.

- ▶ to supply all important grease lubrication points with lubricant during operation of the mixer!

- ▶ The system comprises a central oil-air lubrication unit and a central grease lubrication unit.

- ▶ **NOTE!**

Lubricating the internal sealing chamber after cleaning of the mixer is to be ensured by a slowing down time of the oil-air application to the sealing points.

Slowing down time: approx. 30 min



- ▶ **NOTE!**

The oil filling devices and oil storage tanks must enable an absolutely contamination-free transfer of the oil into the storage vessel.

- ▶ Lubricant consumption is very small as compared to grease lubrication



- ▶ Owing to this system the machine requires very little maintenance in the field of lubricant supply.

Subject to correct integration of the control unit and maintenance of the system the working reliability of the machine and service life of the parts is increased.

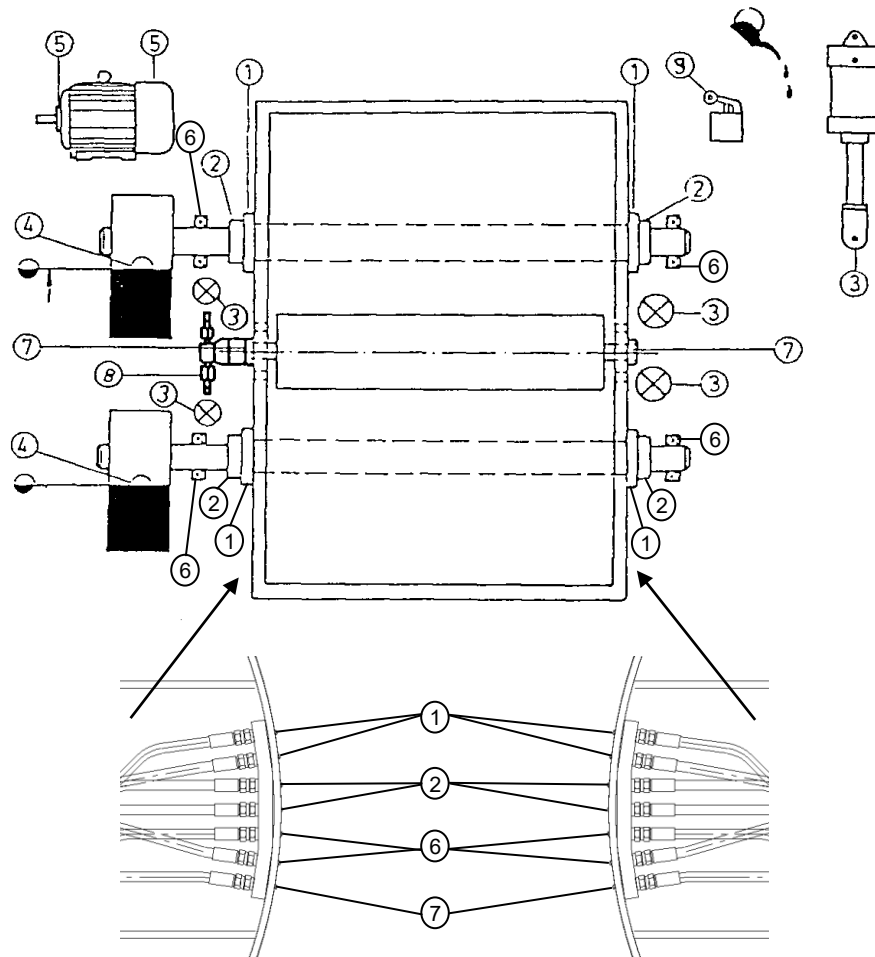
# 3. Lubrication chart



1. **Internal sealing chamber of the mixing shaft seal**  
Sealing point to the interior space of the mixing trough – most highly stressed sealing point.  
Grease filling prevents mix components from entering the sealing chamber – red lubricating nipples
2. **External sealing chamber of mixing shaft seal**  
Supplies sliding faces of the seal with grease – yellow lubricating nipples
3. **Hinges of discharge door operation**
4. **Gear oil level**
5. **Motor bearing**
6. **Mixing shaft bearing** – blue lubricating nipples
7. **Discharge door bearing** – blue lubricating nipples
8. **Ball joints at the torque support**
9. **Limit switches / hinges at the trough cover**

Inspection period		Pos.	Type of lubrication						Subassembly	Maintenance unit	Scope of inspection and maintenance work	Amount of grease g		
from h	until h		2.1	2.2	2.3	2.4	2.5	2.6						
8	10		X	X	X	X	X	X	Discharge door operation hydraulic (option)	lubrication unit	<ul style="list-style-type: none"> <li>- oil level</li> <li>- oil temperature</li> <li>- check lines and screw connections for oil leakages</li> <li>- see Technical Documents</li> </ul>			
8	10	1	X	X					Mixing trough seal	inner sealing chamber of shaft sealing  	<ul style="list-style-type: none"> <li>- clean lubricating nipples</li> <li>- regrease until clean grease comes out on the inside of the mixing trough</li> <li>- <b>NOTE!</b> Fill grease into the sealing chamber only <b>after</b> having cleaned the interior of the trough</li> </ul>			
8	10	1			X	X	X		Mixing trough seal	internal sealing chamber of shaft sealing  	<ul style="list-style-type: none"> <li>- actuate the central lubrication at the control unit</li> <li>- Check (commissioning phase) whether clean grease comes out on the inside of the mixing trough</li> <li>- <b>NOTE!</b> Fill grease into the sealing chamber only <b>after</b> having cleaned the interior of the trough</li> </ul>			



Inspection period		Pos.	Type of lubrication								Subassembly	Maintenance unit	Scope of inspection and maintenance work	Amount of grease g		
from	until		2.1	2.2	2.3	2.4	2.5	2.6								
h	h															
8	10				X	X	X	X			Central lubrication	lubrication / control unit	- proper function unless the devices are integrated in the control unit of the plant. (warning signals see Technical Documents)			
8	10			X	X	X		X			Central lubrication grease	grease vessel	- check grease level, refill if necessary			
8	10							X	X		Central lubrication oil-air	oil tank	- check oil level, refill if necessary			
40	50	2	X	X	X		X				Mixing trough seal	external sealing chamber of shaft seal (labyrinth design)	- clean grease nipples - regrease until clean grease comes out on the outside			
40	50	2	X	X	X		X				Mixing trough seal	external sealing chamber of shaft seal (shaft sealing ring design)	- clean grease nipples - regrease	10		
40	50	3	X	X	X	X	X	X			Discharge door operation pneumatic	hinges pneumatic cylinder	- oil - spray (e.g. using MoS <sub>2</sub> -spray)			

Inspection period		Pos.	Type of lubrication								Subassembly	Maintenance unit	Scope of inspection and maintenance work	Amount of grease g		
from h	until h		2.1	2.2	2.3	2.4	2.5	2.6								
40	50	3	X	X	X		X				Discharge door operation hydraulic (option)	hinges hydraulic cylinder	- clean grease nipples - regrease	5		
40	50	4	X	X	X	X	X	X			Drive	gear unit	- check: · gear oil level, refill oil if required · gear temperature - see Technical Documents			
200	300	7	X	X	X		X				Discharge door/ discharge flap	pedestal bearing	- clean grease nipple - regrease	5		
200	300			X	X	X	X	X			Central lubrication	lubrication unit(s), lines	- proper connection of lines - tightness - function			
200	300						X	X			Mixing trough seal	internal sealing chamber of shaft sealing	- check slowing-down time to spray the oil-air mix (until approx. 30 minutes after the mixing trough cleaning has ended)			

Inspection period		Pos.	Type of lubrication								Subassembly	Maintenance unit	Scope of inspection and maintenance work	Amount of grease g		
from	until		2.1	2.2	2.3	2.4	2.5	2.6								
h	h															
200	300	1			X	X					Mixing trough seal	internal sealing chamber of shaft sealing 	- check whether clean grease comes out on the inside of the mixing trough - <b>NOTE!</b> Owing to wear in the labyrinth are the amount of grease may increase during the service life. The cycle time of the pump must then be adapted accordingly (see Technical Documents).			
200	300		X	X	X	X	X	X			Discharge door operation hydraulic (option)	lubrication unit	- <b>First</b> oil change (oil type and amount see Technical Documents)			
200	300	6	X	X	X		X				Mixing shaft bearings		- clean grease nipples - regrease	20		
200	300	8	X	X	X		X				Drive	ball joints on torque support	- clean grease nipples - regrease	5		
200	300	9	X	X	X	X	X	X			Trough cover	limit switches hinges	- oil			
200	300		X	X	X	X	X	X			Discharge door operation hydraulic (Option)	lubrication unit	- check return line filter, replace if required - check air filter, replace if required			

Inspection period		Pos.	Type of lubrication								Subassembly	Maintenance unit	Scope of inspection and maintenance work	Amount of grease g			
from h	until h		2.1	2.2	2.3	2.4	2.5	2.6									
1000	1500		X	X	X	X	X	X	X			Drive	gear unit	- <b>first</b> oil change (oil type and amount see Technical Documents)			
1500	2000	5	X	X	X	X	X	X	X			Drive	motor bearing with regreasing device	- clean lubricator nipples - regrease	45		
6000	9000	4	X	X	X	X	X	X	X			Drive	gear unit	- oil change - see Technical Documents			
10000	15000		X	X	X	X	X	X	X			Drive	fluid coupling (option)	- oil change (oil type and amount see Technical Documents)			
20000	22000	5	X	X	X	X	X	X	X			Drive	motor bearings without regreasing device	- rinse bearings - replace defective bearings - change grease (see maintenance instructions on motor) - see Technical Documents			
20000	22000		X	X	X	X	X	X	X			Discharge door operation hydraulic (option)	lubrication unit	- oil change - see Technical Documents			

## Maintenance

# Operating Instructions

1.	<i>General Instructions .....</i>	2
2.	<i>Discharge Door Safety.....</i>	4
3.	<i>Discharge Flap Safety .....</i>	5
4.	<i>Trough Wearing Parts.....</i>	6
5.	<i>Wearing parts of the Discharge Door.....</i>	7
6.	<i>Replacement of Cylinder Protection .....</i>	8
7.	<i>Replacement of Pedestal Bearings .....</i>	9
8.	<i>Wearing Parts of Discharge Door Flap .....</i>	10
9.	<i>Replacement of Discharge Door or Discharge Flap .....</i>	11
10.	<i>Replacement of Cylinders.....</i>	12
11.	<i>Replacement of Cylinder Seals.....</i>	13
12.	<i>Replacement of Mixing and Lateral Blades .....</i>	14
13.	<i>Replacement of Mixing Arms.....</i>	15
14.	<i>Replacement of V-Belts on externally arranged V-Belt Drive .....</i>	17
15.	<i>Replacement of V-belts on internally arranged V-Belt Drive .....</i>	18
16.	<i>Replacement of Motor(s).....</i>	19
17.	<i>Replacement of Slip-On Gear Units .....</i>	20
18.	<i>Repair on Slip-On Gear Units.....</i>	22
19.	<i>Replacement of Rubber Components in Synchronous Couplings.....</i>	23
20.	<i>Replacement of Mixing Shafts .....</i>	24
20.1	<i>Non-adjustable axial face seal .....</i>	25
20.2	<i>Adjustable axial face seal .....</i>	26
21.	<i>Replacement of Mixing Shaft Bearings.....</i>	28
22.	<i>Replacement of Axial Face Seals .....</i>	29

# 1. General Instructions



- ▶ **NOTE!**  
For safety instructions and safety requirements, see
  - > Group: User information
    - > Group: General safety instructions



- ▶ **ATTENTION!**  
Only commence checking and maintenance work and only remove cover doors, guards and other machine parts once:
  - > Repair switch has been set to “Off” and locked
  - > key is kept in a safe place protected from unauthorised access,
  - > “Maintenance work” sign is attached to the repair switch
  - > stopping times have been observed for moving machine parts.



- ▶ **DANGER!**  
Check machine before switching on and eliminate sources of danger
  - > Guards must be in place
  - > Housing closed and locked
  - > Remove tools from inside and around the machine
  - > Service work hazards in machine environment and from the machines insalled in the process chain



- ▶ **NOTE!**  
Inadequate or poor servicing and maintenance will increase susceptibility to malfunctions and repair and reduce warranty cover.
- ▶ In relation to operating conditions, the user must define:
  - interval and scope of service and maintenance work
  - Service and maintenance schedule



- ▶ **NOTE!**  
Carrying out service and maintenance work:
  - > Changing of wearing parts and performance of simple repair work (e.g. housing seal) by the user’s qualified, skilled personnel
  - > Major repairs by machine manufacturer’s skilled personnel
- ▶ For welding work, see Group: Assembly and Electrical Connection



- ▶ **DANGER!**  
Install a safeguard against rotation!  
The mixing shafts must be prevented from turning if personnel is inside the mixing compartment while service work is being carried out:
  - > place wedges between the mixing blades and trough walls or material bed or
  - > place a wedge on each side of the gear belt wheel to block the V-belt drive (only where synchronous coupling is installed)
  - > remove anti rotation element after completing the service work



- ▶ **IMPORTANT!**  
If electrical connections of the drive motors had been removed for repair work then:
  - > Check the turning direction before putting into service again. Refer to Group: Assembly/Electrical Connection



- ▶ Replace fixing elements, e.g. screws, nuts, bolts, by new ones of identical quality (material, strength) and design.
- ▶ For tightening torques of screw connections see Technical Documentation.
- ▶ **NOTE!**  
For figures for Maintenance Instructions see Spare Parts List
  
- ▶ **NOTE!**  
After each disconnecting of the mixer motor(s) checking of the turning direction before putting into service again. Refer to Group: Assembly/Electrical Connection

## 2. Discharge Door Safety



- ▶ **ATTENTION!**  
The discharge door is arrested with a socket pin.

- ▶ Installation of the locking:
  - Take socket pin (2) from the keeping eye (1)
  - Insert socket pin (2) into locking tube (3)
  - Tighten locking screw (4).

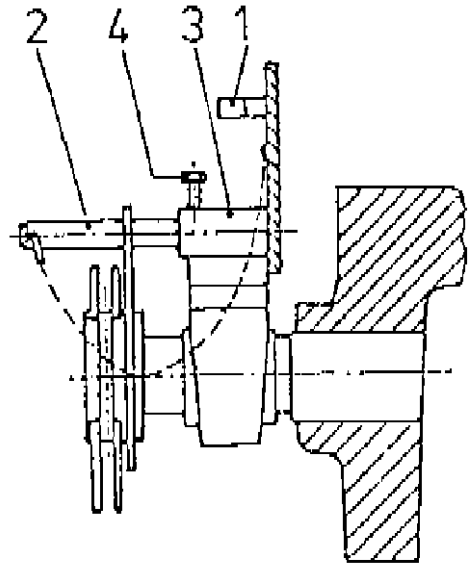

bd00022



- ▶ **DANGER!**  
The discharge door must be fastened with the socket pin during all repair and maintenance works executed on the mixer, e.g. when replacing wearing parts (mixing blades, tiles, etc.) or machine parts. It serves to avoid accidents in the discharge door zone.



## 3. Discharge Flap Safety



- ▶ **DANGER!**  
For all work during which the discharge flap cannot be held safely in all positions because of missing pressure in the cylinders, disconnected current, resp., the discharge flaps open due to dead weight up to the cg position. For jamming effect the flap could stop even before reaching the center of gravity position.



- ▶ **ATTENTION!**  
When working in the mixer suitable safety measures must be taken (e.g. Maintenance platforms under the mixer, applying the full body harness)!

## 4. Trough Wearing Parts



- ▶ **ATTENTION!**  
Switch off the machine:
  - > Repair switch to position "OFF" and locked by key
  - > Keep key safely against unauthorized use
  - > Put warning sign "Maintenance Work" on repair switch
  - > Wait for slow-down period of moving machine parts



- ▶ **ATTENTION!**  
Wait for immobilization of mixing shaft (check on the mixing shaft between bearing case and machine housing) and opening of locking unit.



- ▶ **DANGER!**  
Install a safeguard against rotation!  
The mixing shafts must be prevented from turning if personnel is inside the mixing compartment while service work is being carried out:
  - > place wedges between the mixing blades and trough walls or material bed or
  - > place a wedge on each side of the gear belt wheel to block the V-belt drive (only where synchronous coupling is installed)
- ▶ Remove wear lining by unscrewing the fastening elements, preferably by means of an impact screw driver
- ▶ Clean the stripped inner trough surfaces, remove any deposits of the mix.
- ▶ Mount the new parts, or old parts with one-side wear, which, however, must be mounted the other way round.
- ▶ Tighten screw connections.
- ▶ Steps of more than 3 mm at the joints of the mounted plates or tiles must be evenly ground.
- ▶ When replacing discharge door covers, discharge door ledges, wearing ledges and wearing plates make sure that discharge door/flap remains floating.



- ▶ **ATTENTION!**  
**After termination of the maintenance operations remove the safeguard against rotation.**



- ▶ **NOTE!**  
see group: Starting and Operation - Break-in Prescriptions before starting the mixer, after change of trough lining, resp.

## 5. Wearing parts of the Discharge Door



- ▶ **ATTENTION!**  
Switch off the machine:
  - > Repair switch to position "OFF" and locked by key
  - > Keep key safely against unauthorized use
  - > Put warning sign "Maintenance Work" on repair switch
  - > Wait for slow-down period of moving machine parts



- ▶ **ATTENTION!**  
Wait for immobilization of mixing shaft (check on the mixing shaft between bearing case and machine housing) and opening of locking unit.



- ▶ **DANGER!**  
Install a safeguard against rotation!  
The mixing shafts must be prevented from turning if personnel is inside the mixing compartment while service work is being carried out:
  - > place wedges between the mixing blades and trough walls or material bed or
  - > place a wedge on each side of the gear belt wheel to block the V-belt drive (only where synchronous coupling is installed)



- ▶ **DANGER!**  
**Consider following, while working on discharge door:**
  - > to avoid unauthorized starting of the discharge door
  - > to take precautions against getting squeezed
  - > to work under the mixer only with permissible maintenance scaffolds
  - > see Discharge Door Safety
- ▶ Remove lateral discharge door covers and discharge door ledges along discharge door.
- ▶ Remove fastening nuts on the lower side of the discharge drum, remove cylinder protection and clean the supporting faces on the discharge door cylinder
- ▶ Mount the new cylinder protection, discharge door ledges and discharge door cover.
- ▶ Make sure that the discharge door remains floating.



- ▶ **ATTENTION!**  
**After termination of the maintenance operations remove the safeguard against rotation.**

## 6. Replacement of Cylinder Protection



▶ **ATTENTION!**

Switch off the machine:

- > Repair switch to position "OFF" and locked by key
- > Keep key safely against unauthorized use
- > Put warning sign "Maintenance Work" on repair switch
- > Wait for slow-down period of moving machine parts



▶ **DANGER!**

**Consider following, while working on discharge door:**

- > to avoid unauthorized starting of the discharge door
  - > to take precautions against getting squeezed
  - > to work under the mixer only with permissible maintenance scaffolds
  - > see Discharge Door Safety
- ▶ Remove lateral discharge door covers and discharge door ledges along discharge door.
- ▶ Remove fastening nuts on the lower side of the discharge drum, remove cylinder protection and clean the supporting faces on the discharge door cylinder
- ▶ Mount the new cylinder protection, discharge door ledges and discharge door cover.
- ▶ Remove socket-pin safety from the discharge door.
- ▶ Make sure that the discharge door remains floating.

## 7. Replacement of Pedestal Bearings



- ▶ **NOTE!**  
This repair should not be executed by the user alone, but always with the assistance of an expert of the mixer manufacturer, who will make available also the necessary tools and technical documentation



- ▶ **ATTENTION!**  
Switch off the machine:
  - > Repair switch to position "OFF" and locked by key
  - > Keep key safely against unauthorized use
  - > Put warning sign "Maintenance Work" on repair switch
  - > Wait for slow-down period of moving machine parts



- ▶ **ATTENTION!**  
Wait for immobilization of mixing shaft (check on the mixing shaft between bearing case and machine housing) and opening of locking unit.



- ▶ **ATTENTION!**  
Discharge door/flap can turn or open. Secure opposite side at first
- ▶ Remove discharge door/flap operation and lever.
- ▶ Secure discharge door/flap against falling down.
- ▶ Release setscrew on the bearing tension ring and open by means of beating in anticlockwise direction.
- ▶ After removing the pedestal bearing fastening screws, take bearing off in axial direction.
- ▶ Mount new bearing, fasten tension ring by beating in clockwise direction and tighten setscrew.
- ▶ Remount lever and discharge door/flap operation.

## 8. *Wearing Parts of Discharge Door Flap*



▶ **ATTENTION!**

Switch off the machine:

- > Repair switch to position "OFF" and locked by key
- > Keep key safely against unauthorized use
- > Put warning sign "Maintenance Work" on repair switch
- > Wait for slow-down period of moving machine parts



▶ **ATTENTION!**

Wait for immobilization of mixing shaft (check on the mixing shaft between bearing case and machine housing) and opening of locking unit.

- ▶ see Discharge door safety!
- ▶ Remove wearing ledges along discharge flap.
- ▶ Release fastening elements on the lower side of the discharge flap, remove flap wearing parts and clean supporting faces on the flap.
- ▶ Mount new flap wearing parts and wearing ledges.
- ▶ Make sure that the discharge flap remains floating!

## 9. Replacement of Discharge Door or Discharge Flap



- ▶ **NOTE!**  
This repair should not be executed by the user alone, but always with the assistance of an expert of the mixer manufacturer, who will make available also the necessary tools and technical documentation



- ▶ **ATTENTION!**  
Switch off the machine:
  - > Repair switch to position "OFF" and locked by key
  - > Keep key safely against unauthorized use
  - > Put warning sign "Maintenance Work" on repair switch
  - > Wait for slow-down period of moving machine parts



- ▶ **ATTENTION!**  
Wait for immobilization of mixing shaft (check on the mixing shaft between bearing case and machine housing) and opening of locking unit.



- ▶ **ATTENTION!**  
Discharge door/flap can turn or open. Secure opposite side at first
- ▶ Removal is always to be made downwards.
- ▶ Remove discharge hopper under the mixer or swing it downward.
- ▶ Remove discharge door or discharge flap operation or drive.
- ▶ Hang up lifting cables to the left and to the right around the axes.
- ▶ Release screw connections on pedestal bearings and lower discharge door or flap.
- ▶ Remove sealing and wearing ledges in the mixing trough and clean supporting faces.
- ▶ Install new discharge door(s) of flap(s).
- ▶ Same proceeding as for removal, however in reverse order.
- ▶ Mount new sealing and wearing ledges.
- ▶ Make sure that the discharge door/flap remains floating!

# 10. Replacement of Cylinders



▶ **ATTENTION!**

Switch off the machine:

- > Repair switch to position "OFF" and locked by key
- > Keep key safely against unauthorized use
- > Put warning sign "Maintenance Work" on repair switch
- > Wait for slow-down period of moving machine parts



▶ **ATTENTION!**

Wait for immobilization of mixing shaft (check on the mixing shaft between bearing case and machine housing) and opening of locking unit.

- ▶ If possible, remove cylinder when the piston rod is drawn in. Arresting of the discharge door or flap lever is necessary. Thus the mounting length remains fixed.
- ▶ Unscrew hose lines and bolts (on cylinder and piston rod side).
- ▶ When mounting the new cylinder observe the correct mounting length and alignment. The bolts must be well greased!



# 11. Replacement of Cylinder Seals



▶ **ATTENTION!**

Switch off the machine:

- > Repair switch to position "OFF" and locked by key
- > Keep key safely against unauthorized use
- > Put warning sign "Maintenance Work" on repair switch
- > Wait for slow-down period of moving machine parts



▶ **ATTENTION!**

Wait for immobilization of mixing shaft (check on the mixing shaft between bearing case and machine housing) and opening of locking unit.



▶ **NOTE!**

The required spare part kits should be kept on stock or ordered well in time from the mixer manufacturer

- ▶ For replacing the cylinder seals, dismantle the cylinder.

## 12. Replacement of Mixing and Lateral Blades



▶ **ATTENTION!**

Switch off the machine:

- > Repair switch to position "OFF" and locked by key
- > Keep key safely against unauthorized use
- > Put warning sign "Maintenance Work" on repair switch
- > Wait for slow-down period of moving machine parts



▶ **ATTENTION!**

Wait for immobilization of mixing shaft (check on the mixing shaft between bearing case and machine housing) and opening of locking unit.



▶ **DANGER!**

see Discharge Door Safety /Discharge Flap Safety

- ▶ Clean mixing tools and remove deposits of the mix, particularly in the area of the blade fastening nuts.
- ▶ Release fastening nuts. If this is not possible, then burn away hexagon nuts.
- ▶ Remove blades and clean supporting faces on the mixing arm. Remove deposits of mixed material.



▶ **NOTE!**

Mount new mixing and lateral blades with simultaneous setting of the radial and axial blade gap.

Minimum gap width = 2 mm in radial and axial direction

- ▶ Setting of the blade gap with simultaneous rotation of the mixing tools by hand and check of the blade gap. The narrowest radial blade gaps should always be measured at the upper blade entry, at the trough wear protection.
- ▶ Upon adjustment of all mixing and lateral blades the screw connections must be firmly tightened and the mixing tools rotated by hand on the V-belt drive. If the blades touch the wear protection they must be reset
- ▶ For tightening torques refer to Technical Documentation



▶ **ATTENTION!**

Make sure that all blade screws are firmly tightened. If blade screws are not firmly tightened, blades will come loose. This will cause the mixing mechanism to block, the mixing shafts to bend and ultimately high repair costs.

# 13. Replacement of Mixing Arms



- ▶ **ATTENTION!**  
Switch off the machine
  - > Set repair switch "OFF" and lock.
  - > Keep the key in a safe place protected from unauthorised access.
  - > Attach "Maintenance Work" sign to the repair switch.
  - > Observe stopping times for moving machine parts.



- ▶ **ATTENTION!**  
Wait until mixing shaft is stationary (check mixing shaft between bearing housing and machine housing) and locking unit is unlocked.



- ▶ **DANGER!**  
Install a safeguard against rotation!  
The mixing shafts must be prevented from turning if personnel is inside the mixing compartment while service work is being carried out:
  - > place wedges between the mixing blades and trough walls or material bed or
  - > place a wedge on each side of the gear belt wheel to block the V-belt drive (only where synchronous coupling is installed)



- ▶ **DANGER!**  
**see Discharge Door Safety /Discharge Flap Safety**
- ▶ Clean mixing tools and remove deposits of the mix, particularly in the area of the fastening elements.
- ▶ Release fastening nuts. If this is not possible, then burn away fixing screws in the gap between arm hub and counterpiece.
- ▶ Remove mixing arm and counterpiece and clean shaft supporting face. Remove deposits of mixed material
- ▶ Install new mixing arm, counterpiece and mixing blade.



- ▶ **NOTE!**  
The screw connection for fastening the mixing arms comprises a hexagonal head screw, hexagon nut and spherical disk, with the latter located below the hexagon nut



- ▶ For torque values, see Technical Documents



- ▶ **ATTENTION!**  
Make sure, that all mixing arms and blade fastening screws are firmly tightened



- ▶ **ATTENTION!**  
After mounting the new mixing arms, the mixing tools must be rotated by hand on the V-belt drive. If the blades touch the wear protection, then they must be reset



- ▶ **ATTENTION!**  
Make sure that all blade screws are firmly tightened. If blade screws are not firmly tightened, blades will come loose. This will cause the mixing mechanism to block, the mixing shafts to bend and ultimately high repair costs.



- ▶ **ATTENTION!**  
Remove anti rotation safeguard after completing maintenance work.

# 14. Replacement of V-Belts on externally arranged V-Belt Drive



- ▶ **ATTENTION!**  
Switch off the machine
  - > Set repair switch "OFF" and lock.
  - > Keep the key in a safe place protected from unauthorised access.
  - > Attach "Maintenance Work" sign to the repair switch.
  - > Observe stopping times for moving machine parts.



- ▶ **ATTENTION!**  
Wait for immobilization of mixing shaft (check on the mixing shaft between bearing case and machine housing) and opening of locking unit
- ▶ Remove V-belt protection device.
- ▶ Release V-belts by displacement of the motor rocker.
- ▶ Remove V-belts and mount new set of V-belts.
- ▶ Only use high-capacity narrow V-belts, see Spare Parts List.
- ▶ Tension V-belts and mount V-belt protection device!
- ▶ For V-belt tensioning, see Technical Documents



# 15. Replacement of V-belts on internally arranged V-Belt Drive



- ▶ **ATTENTION!**  
Switch off the machine
  - > Set repair switch "OFF" and lock.
  - > Keep the key in a safe place protected from unauthorised access.
  - > Attach "Maintenance Work" sign to the repair switch.
  - > Observe stopping times for moving machine parts.



- ▶ **ATTENTION!**  
Wait for immobilization of mixing shaft (check on the mixing shaft between bearing case and machine housing) and opening of locking unit



- ▶ Remove V-belt protection device.
- ▶ **DANGER!**  
Install a safeguard against rotation!  
The mixing shafts must be prevented from turning if personnel is inside the mixing compartment while service work is being carried out.
- ▶ For MFC coupling: remove rubber components by means of cranked double ratchet ring spanner.
- ▶ For N-Eupex coupling: release screws on claw ring and move claw ring horizontally until uncoupled. Release screws on female part of coupling, remove female part.
- ▶ Release V-belts by displacement of the motor rocker.
- ▶ Remove V-belts and mount new set of V-belts.
- ▶ Only use high-capacity V-belts, see Spare Parts List.
- ▶ Observe the instructions for coupling and uncoupling, refer to Group: Maintenance and Inspection.
- ▶ Couple synchronous coupling again. Same proceeding as for uncoupling, however in reverse order.
- ▶ Check correct adjustment of mixing tools to each other!
- ▶ Tension V-belts and mount V-belt protection device.



- ▶ **ATTENTION!**  
Remove anti rotation safeguard after completing maintenance work.



- ▶ **For V-belt tensioning, see Technical Documents**

# 16. Replacement of Motor(s)



- ▶ **NOTE!**  
This repair should not be executed by the user alone, but always with the assistance of an expert of the mixer manufacturer, who will make available also the necessary tools and technical documentation



- ▶ **ATTENTION!**  
Electrical work must only ever be performed by authorized skilled personnel!!



- ▶ **ATTENTION!**  
Switch off the machine:
  - > Repair switch to position "OFF" and locked by key
  - > Keep key safely against unauthorized use
  - > Put warning sign "Maintenance Work" on repair switch
  - > Wait for slow-down period of moving machine parts



- ▶ **ATTENTION!**  
Wait for immobilization of mixing shaft (check on the mixing shaft between bearing case and machine housing) and opening of locking unit.
- ▶ Remove V-belt guard, detention V-belts and remove V-belts.
- ▶ Remove motor V-belt pulley and hydraulic coupling, resp. Hydraulic coupling see Technical Documentation.
- ▶ Place a lifting device over the motor to be removed. Then put two ropes around the motor at the drive and the fan side, hang them into the lifting device and pull until the ropes are uniformly tight.
- ▶ Remove motor fastening screws. Afterwards attach a second lifting device laterally at the motor and by pulling at an angle put the motor in its lowering position. Then lower the motor onto the platform.
- ▶ Mount the new motor. Same proceeding as for removal, but in reverse sequence.
- ▶ Mount the motor V-belt pulley, or hydraulic coupling, resp. Check alignment of V-belt pulleys to each other. Move motor in axial direction, if necessary. Hydraulic coupling see Technical Documentation.
- ▶ Attach and tension V-belts. Mount V-belt guard.



- ▶ **NOTE!**  
Before putting into service again check the turning direction. Refer to Group: Assembly/Electrical Connection.

# 17. Replacement of Slip-On Gear Units



- ▶ **NOTE!**  
This repair should not be executed by the user alone, but always with the assistance of an expert of the mixer or gearbox manufacturer. Special knowledge and technical documentation is required.



- ▶ **ATTENTION!**  
Switch off the machine:
  - > Repair switch to position "OFF" and locked by key
  - > Keep key safely against unauthorized use
  - > Put warning sign "Maintenance Work" on repair switch
  - > Wait for slow-down period of moving machine parts



- ▶ **ATTENTION!**  
Wait for immobilization of mixing shaft (check on the mixing shaft between bearing case and machine housing) and opening of locking unit.



- ▶ **DANGER!**  
Install a safeguard against rotation!  
The mixing shafts must be prevented from turning if personnel is inside the mixing compartment while service work is being carried out:
  - > place wedges between the mixing blades and trough walls or material bed or
  - > place a wedge on each side of the gear belt wheel to block the V-belt drive (only where synchronous coupling is installed)

- ▶ Dismount motor and V-belts.



- ▶ **DANGER!**  
**Prevent gear unit you are removing from tipping to side, before releasing torque support and synchronous coupling!**
- ▶ Suspend the gear unit vertically upward by means of a lifting device.
- ▶ Loosen drive support by knocking out a bolt on the hinge head.  
The bolt has been bonded by means of metal adhesive, e.g. Loctite; therefore heat the butt straps shortly to approx. 180-200 °C.
- ▶ Turn drive support (turnbuckle with hinge head) downwards.
- ▶ Separate synchronizing coupling.
- ▶ After removing the gearbox cover and end disk, attach extracting device with light metal hollow piston cylinder (Lukas) and extract the gear unit by actuating the piston hand pump. If no Lukas cylinder is available then insert several spacer pieces instead of the cylinder into the extracting device and withdraw the gear unit by hand by uniform tightening of all 4 nuts.





▶ **ATTENTION!**

When setting down the gear unit, make sure that oil is unable to escape from vent.

- ▶ After removal clean the shaft by means of petrol and emery cloth, and apply some grease.
- ▶ The mounting of the slip-on gear unit to the shaft is made by hand by means of a threaded spindle.

- Thread diameter = M 24 for mixer sizes 1,25 - 4,00 m<sup>3</sup>
- Thread diameter = M 36 for mixer sizes 5,00 - 6,00 m<sup>3</sup>

- ▶ Mount the motor, put on and tension V-belts.
- ▶ Mount drive support again, provide bolt with metal adhesive, e.g. Loctite, install it and put on V-belts.
- ▶ Remount synchronous coupling:
- ▶ **Remove the safeguard against rotation.**



▶ **ATTENTION!**

Adjust mixing mechanisms to correct mutual setting:

- > Mark on shaft ends must be aligned with marks on hollow gear unit shafts.
- > Correctly position both drive-end lateral arms in relation to each other, see Spare parts list, Group: Mixing mechanism

- ▶ Couple synchronous coupling.
- ▶ Adjust coupling alignment in two planes:
  - vertically: by adjusting the turnbuckle
  - horizontally: by placing a fitting ring between gear unit and spacer bushing
- ▶ Screw end disk and gearbox cover on, fill gear oil in.
- ▶ Prior to starting, rotate the mixing tools one full revolution by hand on the V-belt drive to check the adjustment of the mixing tools.



▶ **NOTE!**

Before putting into service again check the turning direction. Refer to Group: Assembly/Electrical Connection.

- ▶ Mount protective guards.

# 18. Repair on Slip-On Gear Units



- ▶ **NOTE!**  
This repair should not be executed by the user alone, but always with the assistance of an expert of the mixer or gearbox manufacturer. Special knowledge and technical documentation is required.



- ▶ **ATTENTION!**  
Switch off the machine:
  - > Repair switch to position "OFF" and locked by key
  - > Keep key safely against unauthorized use
  - > Put warning sign "Maintenance Work" on repair switch
  - > Wait for slow-down period of moving machine parts



- ▶ **ATTENTION!**  
Wait for immobilization of mixing shaft (check on the mixing shaft between bearing case and machine housing) and opening of locking unit.
- ▶ The sealing rings may be replaced by the operator, provided that the sealing lip has not left traces of running-in on the sealing faces of the shaft.

# 19. Replacement of Rubber Components in Synchronous Couplings



- ▶ **ATTENTION!**  
Switch off the machine:
  - > Repair switch to position "OFF" and locked by key
  - > Keep key safely against unauthorized use
  - > Put warning sign "Maintenance Work" on repair switch
  - > Wait for slow-down period of moving machine parts



- ▶ **ATTENTION!**  
Wait for immobilization of mixing shaft (check on the mixing shaft between bearing case and machine housing) and opening of locking unit.
- ▶ Remove V-belt protecting device.
- ▶ Uncouple synchronous coupling.
- ▶ For MFC coupling: remove rubber components by means of cranked double ratchet ring spanner and mount new rubber components.
- ▶ For N-Eupex coupling: Release screws on claw ring and move claw ring horizontally until uncoupled. Press out rubber components by means of a screw driver and press in new rubber components.
- ▶ Instructions for coupling and uncoupling must be observed, refer to Group: Maintenance and Inspection, Maintenance and Inspection Plan.
- ▶ Couple synchronous coupling again. Same proceeding as for removal, but in reverse sequence.
- ▶ Tension V-belts and mount V-belt protection device.
- ▶ **IMPORTANT!**  
Adjustment of mixing tools see Spare Parts List  
Check if mixing tools are rotating freely



## 20. Replacement of Mixing Shafts



- ▶ **NOTE!**  
This repair operation should not be performed by the user without assistance. It is recommended that repairs be carried out by an expert engineer who can provide necessary tools and technical documents.



- ▶ **ATTENTION!**  
Switch off the machine:
  - > Repair switch to position "OFF" and locked by key
  - > Keep key safely against unauthorized use
  - > Put warning sign "Maintenance Work" on repair switch
  - > Wait for slow-down period of moving machine parts



- ▶ **ATTENTION!**  
Wait for immobilization of mixing shaft (check on the mixing shaft between bearing case and machine housing) and opening of locking unit.
- ▶ bearing case and machine housing) and opening of locking unit.
- ▶ see Discharge Door Safety /Discharge Flap Safety
- ▶ Remove slip-on gear units, see Replacement of slip-on Gear Units.
- ▶ Dismount mixing tools.
- ▶ Remove bearing cover, dust cover and wearing rings on either side.
- ▶ Support shaft in the trough on both sides.
- ▶ Pull off bearing bodies with self-aligning roller bearings by means of jacking screw.
- ▶ Release and pull-off locating ring and shaft bush.
- ▶ Remove shaft to the side.
- ▶ Mount new shaft as well as seals, bearing bodies, bearings and bearing cover
  - Mounting instructions:  
see: Replacement of Axial Face Seals  
see: Replacement of Mixing Shaft Bearings
  - The following illustration shows the design of the shaft sealing.

## 20.1 Non-adjustable axial face seal

- ▶ The shaft bush (2) is fixed on the mixing shaft (1) in its axial position to the connecting flange (3). The bipartite axial face seal (5) is seated in the locating ring (4) and the shaft bush (2) by means of O-rings. For the proper functioning of the axial face seal it is important that it is prestressed in installed condition. Therefore mind the following proceeding for assembly:
  - Before mounting the split ring seals (8 + 9) the mixing shaft must be aligned and dimension 's' between shaft bush (2) and mixer housing must be set.  $s = 2 \pm 0,5 \text{ mm}$ .
  - In case of deviations levelling plates are slipped onto the shaft, or corresponding rework is required on shaft bush (2).
  - With locating ring (4) pulled out, the distance X measured between contact surface of connecting flange (3) and shaft bush (2) must be checked.

Correct distance (X):

for mixer sizes:	1,25 - 1,67 m <sup>3</sup>	X = -5 ± 0,5 mm (set back)
	1,85 - 3,0 m <sup>3</sup>	X = 7 ± 0,5 mm
	3,5 - 4,0 m <sup>3</sup>	X = 10 ± 0,5 mm
	5,0 - 7,0 m <sup>3</sup>	X = 3 ± 0,5 mm

Check of gap size 'z' between dust cover (8) and wearing ring (9)  
 $z = 2,0 \pm 0,5 \text{ mm}$ .

If the gap size is inferior, it is to be adjusted by means of shims (shim to DIN 127 or tooth lock washer to DIN 17222) between dust cover (8) and shaft bush (2) depending on the deviation.

- ▶ When replacing the drive side seals mount slip-on gear, refer to: replacing of the gearbox (for mixing tool position refer to spare part list).



- ▶ **IMPORTANT!**  
Check if mixing tools are rotating freely

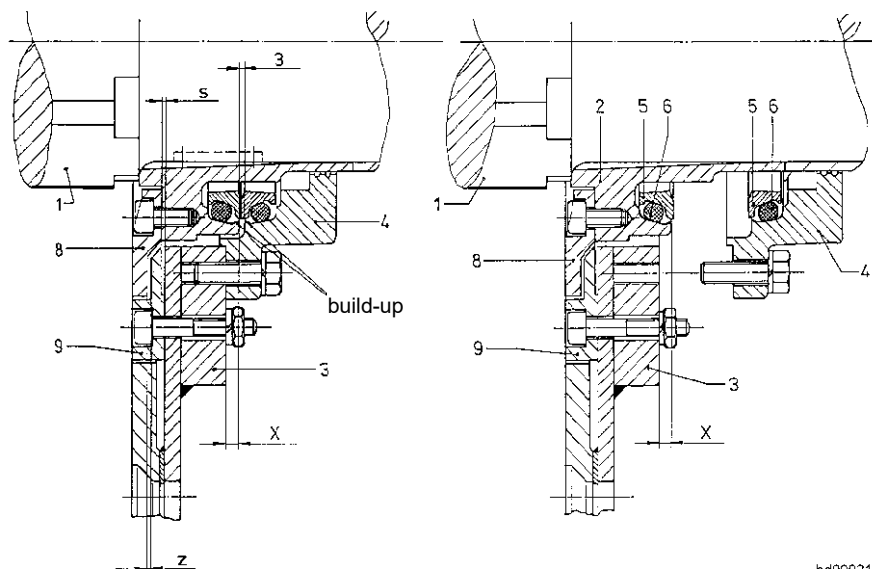

bd00021

**20.2 Adjustable axial face seal**

- ▶ The shaft bush (2) is fixed on the mixing shaft (1) in axial position to the connecting flange (3). The bipartite axial face seal (5) is seated in the locating ring (4) and the shaft bush (2) by means of O-rings. For proper functioning of the axial face seal it is important that it is prestressed in installed condition. Therefore mind the following proceeding for assembly.

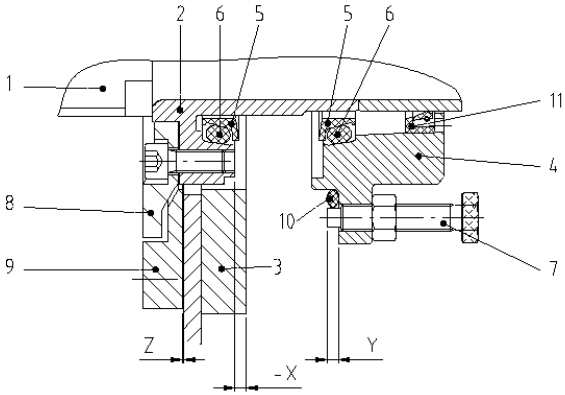

- ▶ Dismount the locating ring (4).
- ▶ Clean locating ring and shaft bush; then check if parts are still ok.
- ▶ You should be able to mount the axial face seals with O-rings in the locating ring applying slight pressure only, to get a pretension to hold the rings.

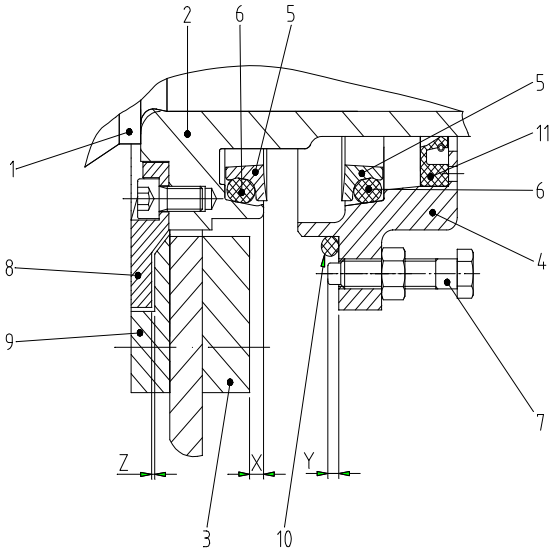

- ▶ The sealing faces must be smooth without any grooves!



- ▶ **ATTENTION!**  
Dimension X must be mediated on the drive side and opposite drive side depending on the mixer size

- **Mixer size: 1.00 to 1.67**  
calculated nominal size: X = - 5 mm  
Y must be set and fixed by means of the forcing screws (7) in dependence on the measured value X (refer to table).

X measured	-	3	3,25	3,5	3,75	4	4,25	4,5	4,75	5	5,25	5,5	5,75	6	6,25	6,5	6,75	7
Y set	+	7	6,75	6,5	6,25	6	5,75	5,5	5,25	5	4,75	4,5	4,25	4	3,75	3,5	3,25	3

- **Mixer size: 1.85 to 3.00**

calculated nominal size: X = 7 mm

Y must be set and fixed by means of the forcing screws (7) in dependence on the measured value X (refer to table).

X measured	5	5.25	5.5	5.75	6	6.25	6.5	6.75	7	7.25	7.5	7.75	8	8.25	8.5	8.75	9
Y set	5	5.25	5.5	5.75	6	6.25	6.5	6.75	7	7.25	7.5	7.75	8	8.25	8.5	8.75	9

- **Mixer size: 3.50 to 4.00**

calculated nominal size: X = 10 mm

Y must be set and fixed by means of the forcing screws (7) in dependence on the measured value X (refer to table).

X measured	8	8.25	8.5	8.75	9	9.25	9.5	9.75	10	10.25	10.5	10.75	11	11.25	11.5	11.75	12
Y set	3	3.25	3.5	3.75	4	4.25	4.5	4.75	5	5.25	5.5	5.75	6	6.25	6.5	6.75	7

- **Mixer size: 4.00 to 7.00**

calculated nominal size: X = 3 mm

Y must be set and fixed by means of the forcing screws (7) in dependence on the measured value X (refer to table).

X measured	1	1.25	1.5	1.75	2	2.25	2.5	2.75	3	3.25	3.5	3.75	4	4.25	4.5	4.75	5
Y set	3	3.25	3.5	3.75	4	4.25	4.5	4.75	5	5.25	5.5	5.75	6	6.25	6.5	6.75	7

- ▶ Check if O-ring (10) and sealing ring (11) have been inserted correctly.
- ▶ Check gap size between dust cover (8) and wearing ring (9):  
z = 2.0 ± 0.5 mm.  
If the gap size is inferior, it is to be adjusted by means of shims (shim to DIN 127 or tooth lock washer to DIN 17222) between dust cover (8) and shaft bush (2) depending on the deviation.
- ▶ When replacing seals on the drive side, mount slip-on gear unit; refer to: replacing of the gearbox (for setting of mixing tools refer to spare part list).
- ▶ **IMPORTANT!**  
Check if mixing tools are rotating freely



- ▶ **NOTE!**  
Before putting into service again check the turning direction. Refer to Group: Assembly/Electrical Connection.

# 21. Replacement of Mixing Shaft Bearings



- ▶ **NOTE!**  
This repair operation should not be performed by the user without assistance. It is recommended that repairs be carried out by an expert engineer who can provide necessary tools and technical documents.



- ▶ **ATTENTION!**  
Switch off the machine:
  - > Repair switch to position "OFF" and locked by key
  - > Keep key safely against unauthorized use
  - > Put warning sign "Maintenance Work" on repair switch
  - > Wait for slow-down period of moving machine parts



- ▶ **ATTENTION!**  
Wait for immobilization of mixing shaft (check on the mixing shaft between bearing case and machine housing) and opening of locking unit.
- ▶ In case of drive side bearing, remove slip-on gear unit proceeding see Replacement of slip-on Gear Units.
- ▶ Support shaft on both sides of the trough.
- ▶ Then unscrew bearing cover and bearing body and withdraw bearing body with self-lager aligning roller bearing by means of jacking screw.
- ▶ Clean bearing body, bearing cover and shaft.
- ▶ Mount again bearing body, self-aligning roller bearing and bearing cover.
- ▶ Remount slip-on gear unit and adjust correct position of mixing tools, see Replacement of Mixing Arms.



## 22. Replacement of Axial Face Seals



- ▶ **NOTE!**  
This repair operation should not be performed by the user without assistance. It is recommended that repairs be carried out by an expert engineer who can provide necessary tools and technical documents.



- ▶ **ATTENTION!**  
Switch off the machine:
  - > Repair switch to position "OFF" and locked by key
  - > Keep key safely against unauthorized use
  - > Put warning sign "Maintenance Work" on repair switch
  - > Wait for slow-down period of moving machine parts



- ▶ **ATTENTION!**  
Wait for immobilization of mixing shaft (check on the mixing shaft between bearing case and machine housing) and opening of locking unit.
- ▶ In case of drive side seal, remove slip-on gear unit, see: Replacement of slip-on Gear Units.
- ▶ Support shaft on both sides of the trough.
- ▶ Then unscrew bearing cover and bearing body and with-draw bearing body together with self-aligning roller bearing by means of jacking screw.
- ▶ Before removing the fixed bearing or replacing the shaft seal on the fixed bearing side (non-drive end) measure alignment between gear coupling halves and note down.
- ▶ Support the shaft in the trough, unscrew and withdraw locating ring.
- ▶ Dismount axial face seals.
- ▶ Clean locating ring and shaft bush, check if parts are OK
- ▶ Builds-up - see fig. Replacement of Mixing Shafts - must still exist, so the axial face seals with O-rings can only be mounted with corresponding pressure.
- ▶ Sealing faces must be smooth without any striae.
- ▶ Insert new axial face seals and mount locating ring, bearing body and bearing cover. Check distance between contact surface of locating ring and shaft bush.
- ▶ **IMPORTANT!**  
Correct distance measure refer to: Replacement of Mixing Shafts
- ▶ Readjust the alignment measured on the gear coupling (only applicable when replacing the seals on the non-drive end).
- ▶ In case of drive side seal replacement mount slip-on gear unit and adjust correct position of mixing tools, refer to Replacement of slip-on Gear Units.

Pos	QTY	Part #	ARTICLE SHORT DESCRIPTION 1	ARTICLE SHORT DESCRIPTION 2	DIM/TYPE	MATERIAL	STANDARD	WEIGHT
1	1	902024942	TECHNICAL SPECIFICATION					
2	1	902010748	INSTALLATION DRAWING					
3	1	902027443	TECHNICAL INSTRUCTIONS		1,00 - 1,67			
4	1	902022200	WORM GEAR		AUMA DRIVES GFC			
5	1	902005092	THREE-PHASE MOTOR		ABB			
6	1	902028599	DISCHARGE DOOR OPERATION PNEU. PARTS	CUSTOMER DOCUMENTATION	CHINA			
7	1	902016489	CENTRAL LUBRICATION GREASE					
8	1	902001153	SAFETY SWITCH		BERNSTEIN			
			<b>END OF BOM!</b>					

	DKXS1,25	TECHNICAL DOCUMENTS	
	902030246		



## Technical Specification

**902024942**

### Twin Shaft Batch Mixer DKXS1,25

Edition

08/15

page

1 - 1

### Process Data

<b>Batch volume</b>	compacted concrete	<b>1,25 m<sup>3</sup></b>
	dry charge	<b>1,88 m<sup>3</sup></b>
<b>Batch weight</b>	max.	<b>3000 kg</b>
<b>Truck mixer discharge<sup>2)</sup></b>	mixing cycles per hour	<b>53</b>
	compacted concrete	<b>66 m<sup>3</sup>/h</b>
<b>Mixture<sup>1)</sup></b>		<b>Transport concrete,</b>
<b>Aggregate size</b>	from/to	<b>0 – 64 mm</b>

### Technical Data

<b>Drive output and mixer equipment</b>	See order confirmation received
<b>Machine weight</b>	See type label
<b>Dimensions</b>	refer to installation drawing

1) Special variants for individual applications can be provided on request

2) 30 sec. mixing time and truck mixer input performance of 0,12m<sup>3</sup> fresh concrete per sec.





The following hazards are not covered by the mixer scope of supply.

This list of measures will not release from studying and observing the operating manual as well as other instructions.

EN 12151	Hazards	Subassembly/ Component	Measures
4.1.1 4.1.2 4.1.4	Squeezing Shearing Pulling-in or getting caught	Trough cover (mixing tools), mixing trough cover	<ul style="list-style-type: none"> <li>- Trough cover shall not allow any access to mixing tools during mixing process or when machine is running.</li> <li>- Access and maintenance hatches are protected by means of locking unit against opening of the mixing trough as long as the mixing tools are still running.</li> <li>- When opening the maintenance hatches a limit switch is actuated preventing the mixer from starting again.</li> <li>- Easily accessible emergency switches in the mixer area.</li> <li>- Openings to observe the mixing process are to be provided with non-removable plexiglass covers (for mixes developing dust or gases) or close-mesh grids</li> <li>- Material feeding devices must be connected such to the mixer that no access to the mixing room is possible.</li> <li>- Electrical locking of the machine to prevent that the mixer will be started and the mixer discharge be actuated inadvertently.</li> <li>- After integration into the steel structure, it is to be checked whether there is any access and thus danger of squeezing and shearing in the mixer discharge area..</li> </ul>

EN 12151	Hazards	Subassembly/ Component	Measures
4.1.10	Catapulting of parts or material	Trough cover Discharge door Discharge flap	<ul style="list-style-type: none"> <li>- Corresponding design of the trough cover and the material feeding devices.</li> <li>- Electrical locking of the machine to prevent that material can be fed during maintenance works.</li> <li>- Mounting of a suitable delivery hopper for a guided and safe material discharge out of the mixer.</li> <li>- Opening of trough cover for discharge subject to supervision.</li> <li>- Measures to identify the hazardous area.</li> </ul>
4.2	Electrical hazard	Drive Safety limit switch, safety locking unit (electro-magnetic) at the trough cover	<ul style="list-style-type: none"> <li>- Professional connection of cables to terminal boxes of mixer motors</li> <li>- Safe, waterproof locking of terminal boxes</li> <li>- Safe mounting and guiding of feed lines</li> <li>- Checking of cables for damages</li> <li>- Mounting of emergency switches in the area of the machine and control system</li> <li>- Fault current circuit breakers or system with similar protection.</li> </ul>
4.7	Hazards by working material	Trough cover Delivery hopper	<ul style="list-style-type: none"> <li>- Dust-tight trough cover</li> <li>- Sealing of access and maintenance hatches</li> <li>- Sealing of material delivery points to the mixer</li> <li>- Mounting of suction devices and filters, resp.</li> <li>- Mounting of a suitable delivery hopper for a guided and safe discharge of the material out of the mixer.</li> <li>- Sealing of the mixer outlet area for mixes developing dust or gases, resp.</li> </ul>
4.10	Failure of the system	Mixer	<ul style="list-style-type: none"> <li>- The following points must be observed for integration of the mixer:               <ul style="list-style-type: none"> <li>• power failure</li> <li>• failure of control units</li> <li>• incorrect software</li> <li>• incorrect installation</li> </ul> </li> </ul>



bd00023

**ATTENTION:**

All wearing parts in the mixing trough must be checked at monthly intervals. Wearing parts must be changed before they start to damage the base structure of the mixing trough, discharge gate or discharge door.



bd00023

**NOTE:**

The useful life of wearing parts may vary widely. This will be governed by different parameters, such as charging situation, type and nature of additives, consistency of the materials being mixed and not least by the gap between the mixing tools and the anti-wear lining which must be as close as possible.

**1. Mixing trough protection**

**1.1 Sheet metal plates**

Although these plates can be reversed and are economical to use, plate thickness in the wear zone must not be allowed to fall below 3 mm.

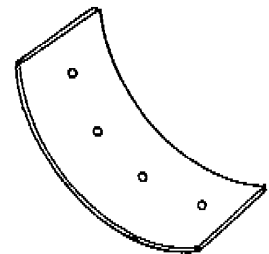

bd00052

**1.2 Tiles of special hard cast material**

These can be used to replace the metal plates without corrective work. Tiles last approximately 3 times longer than metal plates. The tiles must be renewed when they have worn down to a thickness about 6 mm (risk of breaking). As a rule, you will only need to replace the lower rows.

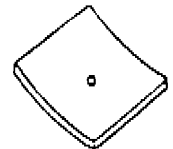

bd00053

**1.3 Ceramic / steel tiles**

These can be used to replace the metal plates or hard cast tiles without the need for corrective work.

Ceramic tiles with a steel base structure last at least twice as long as hard cast tiles and can be worn down as far as the steel base structure.

Plastic-type mixing blades should be selected.

**1.4 Ceramic lining cemented directly in place**

Special measures are required for installing this ceramic lining. Please consult our Customer Service Department for further details. Plastic mixing blades must be selected for this lining type as well.



**2. Trough end-wall protection**

**2.1 Sheet metal plates**

Although individual segments may be reversed, plate thickness in the wearing zone must not be allowed to fall below 6 mm.

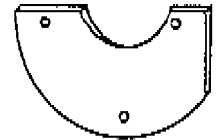

bd00054

**2.2 Tiles of special hard cast material**

For casting reasons, the segments are of different design. This may be replaced by the metal sheet version without reworking

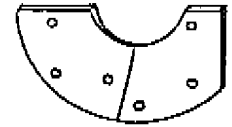

bd00055

**2.3 Sealing plates and lateral wearing plates for the discharge doors**

In view of the necessity for the discharge doors to form a tight seal, these metal plates must only be allowed to wear down to such an extent that adjusting the sealing plates still ensures that the discharge doors form a tight seal at the sides.

To adjust the sealing plates, refer to spare parts list.



bd00056

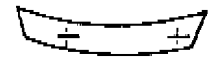

bd00057

**2.4 Ceramic / steel tiles**

The tiles are the same shape as the sheet metal plates, and are otherwise structured as described in 1.3.

**2.5 Ceramic lining cemented directly in place**

As described in 1.4.

**3. Mixing blades, central**

**3.1 Mixing blades of special hard cast material**

must be adjusted at the latest when the distance from the trough protection in the lower part of the mixing trough has reached 10 mm.

The normal radial gap setting is approx. 2 mm at the narrowest point.

Turn mixer and check the gap widths.





### 3.2 Plastic mixing blades

must be checked frequently to ensure that the gap setting remains as small as possible since any major gap will result in increased wear, particularly at the plastic edge facing the trough protection. As far as the radial gap setting is concerned, the plastic blade may contact the trough lining at the tightest point.

Turn mixer and check gap widths and points of contact.

For type: LESX or DKX

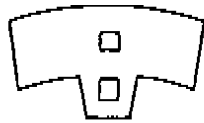

bd00058

For type: LES or DK

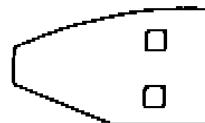

bd00059

## 4. Mixing arms, lateral

**4.1** are provided with mixing blades and lateral plates of **special-hard cast material** that can be adjusted in both the axial and radial direction, permitting compensation for wear on the scraping edges. If the side shovel is readjusted the side panel must also be readjusted flush-aligned to the side shovel. The arm protection must not be spaced more than 5 mm from the end-wall. The normal radial and axial gap setting is approx. 1 mm at the tightest point.

Turn mixer and check gap widths.

**4.2** provided with mixing blades and lateral plates in **plastic** must be frequently checked to ensure that the gap setting remains as small as possible since any major gap will result in increased wear, particularly at the plastic edge facing the trough and end-wall protection. These plastic blades and plates can also be adjusted in both the axial and radial direction, and may contact the anti-wear lining when the gap is adjusted to the tightest setting. If the side shovel is readjusted the side panel must also be readjusted flush-aligned to the side shovel.

Turn mixer and check gap widths and points of contact.

With ceramic lining the distance between arm protection and end-wall should be as small as possible (although there must be no contact) and may be adjusted by fitting a washer between arm protection and side arm.

Für Typ: LESX oder DKX  
Mischarme, links

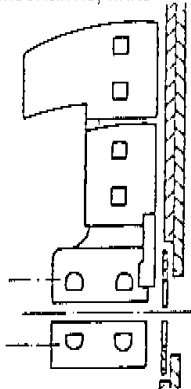

bd00060

Für Typ: LESX oder DKX  
Mischarme, rechts

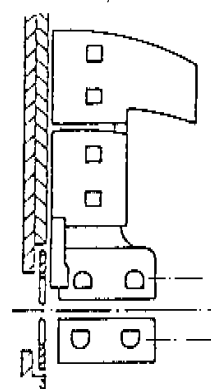

bd00061



bd00023



**ATTENTION!**

Small gap widths -> low wear  
Large gap widths -> high wear

**5. Mixing arms, central**

Refer to Technical Documentation for details on checking for wear: Instructions on inspecting central arm.

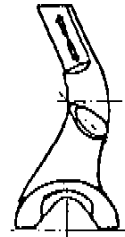

**6. Cylinder protection at discharge gate**

This must be renewed when it has worn down as far as the base structure at the beater arms. To do this, the closed discharge gate must be secured by the locking bolt, refer to Operating Instructions, Group: General Safety Instructions.

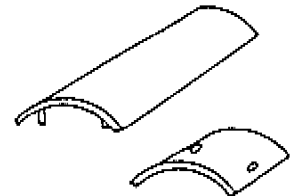

bd00065

**7. Gate strips and sealing strips**

Must be replaced when it is not longer possible to move them closer than 1 mm to the discharge door, anti-wear plates or gate cylinder at the fixing slots. (Discharge gate or discharge door can then no longer be sealed.)

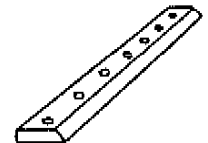

bd00067

**8. Gate cover**

Located at the bottom of the gate valve covers/housings are grooves/markings/indentations which serve for wear monitoring. If these become visible from above the covers/housings require replacement.



bd00068

**9. Coarse grain seal (Dry materials mixer DMX)**

The seals must be replaced as soon as these cannot be adequately readjusted. For the sealing panels at the side cf. to 2.3

**10. Fine grain seal (Dry materials mixer DMX)**

In case of tightness issues examine the gab and the sealing hose for damages and replace if required



**11. Dust cover made of special white iron**

This is the inner closure of the shaft seal. The wear depends upon the radial parallelism of the gap against the end wall protection. Replace the dust cover when the gap size exceeds 5 mm.

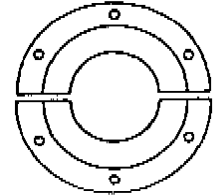

bd00070

**12. Wear ring of the dust cover made of special white iron**

The wear ring is located between the dust cover and the end wall tile and must be replaced together with the dust cover

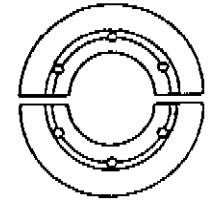

bd00069

**ATTENTION!**

If, due to wear, the cross-section at the weakest point has reached the dimension indicated, the mixing arm can no longer be used and must be replaced for safety reasons.

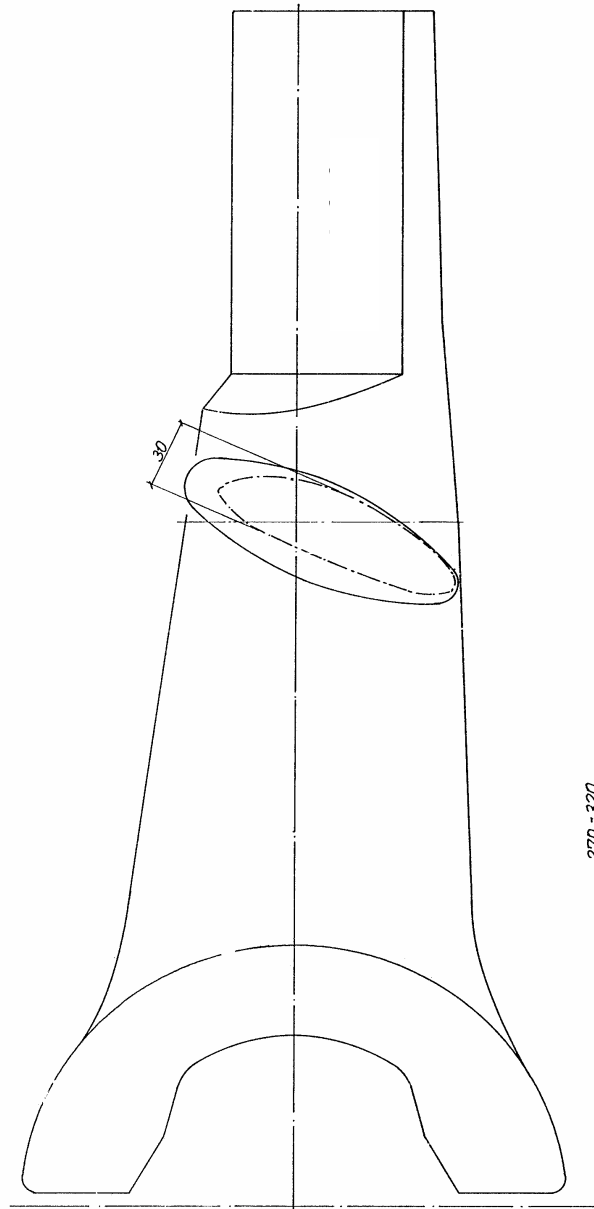



### 1. Tensioning torque for bolt connections

Dimension	M 8	M 10	M 12	M 16	M 20	M 24	M 27	M 30	M 36	M 42
Property class 8.8 Nm <sub>1)</sub>	21	42	72	174	340	580	855	1160	2030	
Property class 10.9 Nm <sub>1)</sub>	29	58	100	245	476	824	1201	1636	2850	
Property class 8.8 and hexagon all-metal nut with clamping part Nm <sub>1) + 5)</sub>	27	52,5	87,5	206	394	660	949	1268		
Property class 8.8 and NORD LOCK self-locking washers Nm <sub>2)</sub>	24	48	82	200	391	667	1018	1334	2335	
Property class 10.9 and NORD LOCK self-locking washers Nm <sub>4)</sub>	32	60	108	263	515	888	1290	1750	3050	
Property class 12.9 and NORD LOCK self-locking washers Nm <sub>4)</sub>	38	75	128	311	610	1052	1533	2091	3420	4560
Property class A 4 stainless steel screw Nm <sub>3) + 6)</sub>	15,3	31,0	52,0	126	245	235	402,2 Friction $\mu_{ges} = 0,14$	549 Friction $\mu_{ges} = 0,14$		
Property class A 4-80 stainless steel screw and NORD LOCK self-locking washers Nm <sub>4)</sub>	19,8	38	67	164	321	553	805	1090	1900	

- 1) Specification are suitable for the friction  $\mu_{ges} = 0,10$   
For non treated surface lubricated with MoS<sub>2</sub>-paste (Molykote) and cadmium electroplated surface non oiled or slightly oiled.
- 2) Specification are suitable for the friction  $\mu_{ges} = 0,11$   
For cadmium electroplated surface lubricated with MoS<sub>2</sub>-paste (Molykote).
- 3) Specification are suitable for the friction  $\mu_{ges} = 0,12$   
For non treated surface lubricated with MoS<sub>2</sub>-paste (Molykote).
- 4) Specification are suitable for the friction  $\mu_{ges} = 0,14$





For non treated surface lubricated with MoS<sub>2</sub>-paste (Molykote).

- 5) Hexagon all-metal nut with clamping part - DIN 6925 - property class 8
- 6) up to M 20 cold rolled, as of M 22 cut

### 1.1 Installation of the NORD-LOCK self-locking lock washers

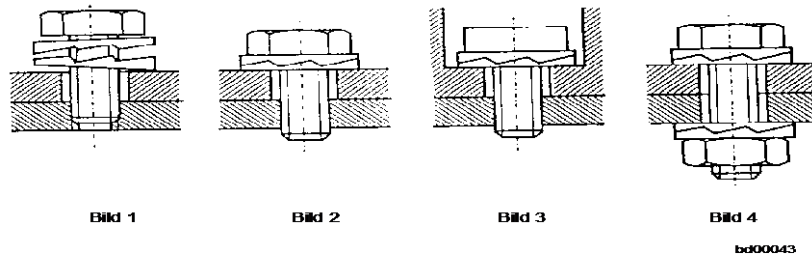
As shown in Fig. 1-4 the lock washers are installed in pairs with the inclined plane to one another. Upon tightening the washer pair is braced against the supporting surface, and the radial ribs on the outside of the lock washer pair enter a positive engagement.





**2. Tensioning torque for bolt connections used in Taper-Lock spring collets**

Type of Taper Lock spring collet	2012 2017	2517 2525	3020 3030	3525 3535	4040	4545	5050	
Tensioning Torque Nm <sup>7)</sup>	31	48	90	113	170	192	271	

**3. Tensioning torque for bolt connections used in tensioning sets**

Part no. (see List of Spare Parts)	Tensioning Torque Nm <sup>7)</sup>
910017100	125
910131600	235
910181700	145
910185700	145
910187500	145
910245200	235
910270200	84
910299300	43
910334700	18
910339000	84
910473700	14
910519600	145
910550500	83
910577500	84
910612500	365
910612600	720

Part no. (see List of Spare Parts)	Tensioning Torque Nm <sup>5)</sup>
910797600	43
920001846	125
920004795	230
920004808	1600
920004810	930
920004812	355
920004880	365
920004881	1220
930212400	145
930394100	70
920008590	83

7) Specification are suitable for the friction no.  $\mu_{ges} = 0,14$  B  
Bolts are slightly oiled.



**1. Preliminary Work..... 2**

**2. Procedure for Determining Initial V-belt Tension ..... 2**

**2.1 Optikrik Initial Tension Measuring Device.....2**

**2.2 Determining Initial Tension Using Length Addition Factor ..... 3**

**2.3 Measuring the initial tension by using a tension gauge (spring balance type) ..... 5**

**3. Tables ..... 6**

**3.1 Table 1 Static Strand Force (N) ..... 6**

**3.2 Table 2 Length Addition Factor per 1000 mm Belt Length..... 7**

**3.3 Table 3 Deflection forces using the spring balance principle..... 8**

		Bk	



## 1. Preliminary Work

- Determining the V-belt profile and the diameter of the small V-belt pulley
- Determining the static strand force (N) at initial assembly or for V-belts that have been run-in (table 1)
- Selecting an appropriate method for determining the initial tension of the V-belt
  - a) Inspection procedure using "Optikrik" device for measuring initial tension, can be used for all shaft centre distances but not for power belts
  - b) Length addition factor

## 2. Procedure for Determining Initial V-belt Tension

### 2.1 Optikrik Initial Tension Measuring Device

The Optikrik II measuring device – with a measuring range from 500 to 1400 N – is available as an option (order no. 920001545).

It is not suitable for measuring power belts.

View

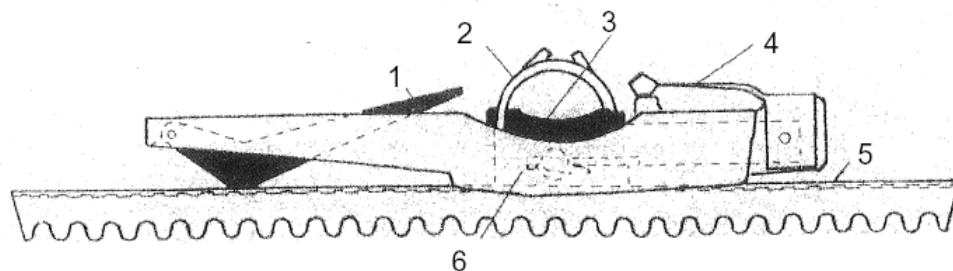

- 1 Display arm
- 2 Rubber finger loop
- 3 Pressure area
- 4 Pocket clip
- 5 Belt
- 6 Compression spring



1. Place the measuring device in the middle between the two pulleys along the back side of the belt. If a set of belts is being used, it should be placed on the middle belt, if possible.  
(Push the display arm fully into the scale area beforehand)
2. Lay the device loosely along the belt to be measured and slowly apply pressure to the pressure area (3) with one finger.
3. Avoid contacting the device with more than one finger during the measuring process.
4. As soon as you hear or feel a distinct 'click', immediately stop applying pressure and the display arm will remain at the measured position.
5. Carefully pick up the device without moving the display arm. Read the value for the static strand force at the intersection between the upper edge of the display arm and the scale area.
6. Decrease or increase the belt tension depending on the measurement result until you are within the desired tension range.  
The required strand force is given in table 1.

**2.2 Determining Initial Tension Using Length Addition Factor**

This procedure is appropriate for single belts and power belts.

- 1 Take the value for the strand force from table 1
- 2 The measurement section "M" of the power belt or single belt is measured in the slack state along the cover plate of the power belt or the back of the single belt.  
The measurement can also be made on the drive side with no tension applied.

		Bk	

3 Procedure:

- a) Lay the power or single belts on the drive and tension them briefly in order to adapt the belt to the pulley profile.
- b) Next, slacken the power or single belts completely.
- c) Mark the measurement section "M" along the open strand length (min. 1000 mm)

**WARNING:** The larger the measurement section, the better the measurement accuracy

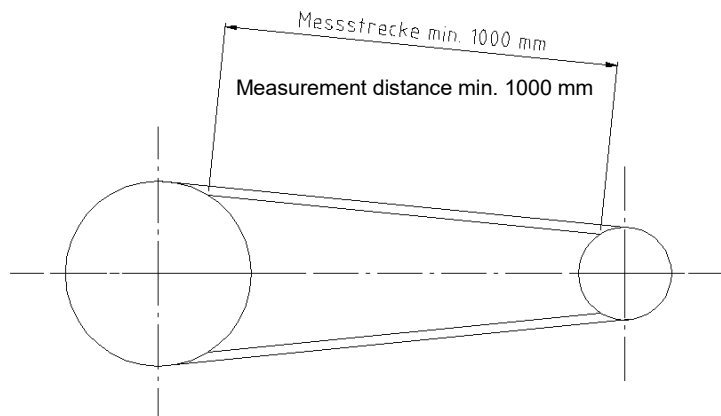

4 Compute the length addition factor A using the formula

$$A = \frac{M \times R}{1000 \text{ mm}}$$

R = elongation factor or stretched distance from table 2

- 5 The power or single belts are placed under tension until they have stretched to the value computed in step 4. This places the proper initial tension on the drive.
- 6 If the drive is restretched, the belts have to be loosened first so that they can be measured and marked in the slack state. Next, proceed as described in steps 3 to 5.

		<b>Bk</b>	

**2.3 Measuring the initial tension by using a tension gauge (spring balance type)**

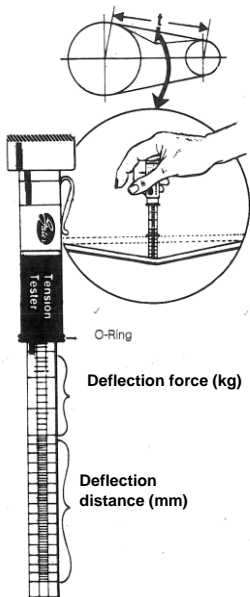

1. Measure the span length
2. Use the bottom ring to set the deflection force  $a$  calculated by using the formula  $a = t/100$  on the distance scale. The top ring should be at zero on the deflection scale. Press on a V-belt or a power belt with the tension tester (approx. in the center of the distance  $t$ ) until the lower O-ring (adjusted to deflection  $a$ ) is at the same level as the unstressed belt next to it (see illustration).
3. Read the deflection force on the top part of the tension gauge. The movable O-ring marks this point to facilitate reading. Please take the reading on the top side of the ring (bring the ring to its initial position before using the tension gauge again)
4. Compare the deflection force to the values indicated in the table under section 3.3. If the measured deflection force reads lower than desired, the drive must be tightened, if the value reads higher the drive must be loosened.

When tensioning power belts multiply the deflection (see table 3.3) by the number of straps of the power belt. When using the tension gauge place a metal rod or small plate on the back of the belt, so all straps are deflected uniformly.

The device can be ordered through our spare part department.  
For the order number please refer to the spare parts list: Drive

		Bk	



### 3. Tables

3.1 Table 1 Static Strand Force (N)

V-belt Profile	Diameter of Small V-belt Pulley	Static Strand Force in N At Initial Assembly	Static Strand Force in N After Run-in Phase
SPB XPB	≤160	650	500
	>160 ≤224	700	550
	>224 ≤355	900	700
	375	1100	850
	400	1200	900
SPC XPC	≤250	1000	800
	>250 ≤355	1400	1100
	>355 ≤560	1800	1400
Power Belt SPB	≤160	850	650
	>160 ≤224	900	700
	>224 ≤355	1200	900
	<355 ≥375	1400	1100
	400	1600	1200



**3.2 Table 2 Length Addition Factor per 1000 mm Belt Length**

Static Strand Force	Elongation Factor or Stretched Distance in mm	
	V-belt Profile	
	SPB	SPC
400	2.0	
450	2.4	
500	2.7	
550	3.1	
600	3.4	2.0
650	3.8	2.2
700	4.1	2.4
800	4.8	2.8
850	5.2	3.1
900	5.5	3.3
1000	6.2	3.7
1100	6.9	4.1
1200	7.6	4.5
1200	8.3	5.0
1400	9.0	5.4
1500	9.87	5.8
1600	10.4	6.3
1700	11.1	6.8



**3.3 Table 3 Deflection forces using the spring balance principle**

Profile	Diameter small pulley in mm	Recommended deflection force daN*	
		min.	max.
SPB/5V	160 – 200	2,9	4,4
	212 – 280	3,6	5,0
	300 - 400	3,8	5,8
SPC	250 - 355	5,1	7,5
	375 - 530	6,0	9,0
XPB/5VX	112 - 118	2,4	3,6
	125 - 140	2,7	4,1
	150 - 170	3,0	4,7
	180 - 200	3,6	5,3
	212 - 280	3,8	5,5
	300 - 400	4,1	6,4
* 1 daN = 1,02 kg			

**Technical Documents**
**900360600**
**Lubricant Oil**

Edition

04/13



Page

1 - 2

	Gear unit			Service unit for Oil-Air lubrication	Fluid coupling	
	Worm gear			Oiler	part of V-belt pulley	Part of coupling
	Synthetic gear oil VG 460 PG to DIN 51502			Spindle oil VG 10 to DIN 51524 and DIN 51517	Gear oil VG 220 to DIN 51517	Hydraulic oil VG 22 to DIN 51524
<b>ARAL</b>	<b>Degol GS 460</b>				<b>Degol BG 220</b>	<b>Vitam GF 22</b>
<b>SHELL</b>	<b>Tivela S 460</b>			<b>Morlina 10</b>	<b>Omala Oil 220</b>	<b>Tellus S 22</b>
<b>BP</b>	<b>Energyn SG-XP 460</b>			<b>Energol HLP-HM 10</b>	<b>Energol GR-XP 220</b>	<b>Energol HLP-HM 22</b>
<b>EXXON MOBIL</b>	<b>Glygoyle HE 460</b>			<b>Mobil DTE 21</b>	<b>Mobilgear 600 XP 220</b>	<b>Mobil DTE 22</b>
<b>CASTROL</b>	<b>Optiflex A460</b>	<b>Alphasyn PG460</b>	<b>Alphasyn GS460</b>	<b>Hyspin AWS 10</b>	<b>Optigear BM 220</b>	
<b>ESSO</b>	<b>Refer to MOBIL</b>			<b>Refer to MOBIL</b>	<b>Refer to MOBIL</b>	<b>Nuto H 22</b>
<b>KLÜBER</b>					<b>Klüberoil GEM 1-220N</b>	
<b>FUCHS</b>	<b>RENOLIN PG 460</b>					
<b>BECHEM</b>	<b>BERUSYNTH EP 460</b>					<b>STAROIL NR 22</b>





	Technical Documents		900360600 00E		
	Lubricant Oil		Edition	04/13	
			Page	1 - 2	
	<b>Hydraulic unit</b> Ambient temperature above + 30 °C Hydraulic oil VG 68 to DIN 51524				
	Ambient temperature 0 bis + 30 °C Hydraulic oil VG 46 to DIN 51524				
<b>ARAL</b>	<b>Vitam GF 68</b>	<b>Vitam GF 46</b>			
<b>SHELL</b>	<b>Tellus S 68</b>	<b>Tellus S 46</b>			
<b>BP</b>	<b>Energol HLP-HM 68</b>	<b>Energol HLP-HM 46</b>			
<b>MOBIL</b>	<b>Mobil DTE 26</b>	<b>Mobil DTE 25</b>			
<b>CASTROL</b>	<b>Hydro E 68</b>	<b>Hydro E 46</b>			
<b>ESSO</b>	<b>Nuto H 68</b>	<b>Nuto H 46</b>			

	Technical Documents			900360700	
	Lubricant Grease			Edition	02/15
				Page	1 - 1
	<b>For all bearings and seals with grease nipples, as well as for automatic lubrication systems</b>  a) Temperature of lubricating points up to 60 °C b) Temperature of lubricating points above 60 °C	<b>For hauling ropes</b>   <b>Attention:</b> The percentage content of solid lubricants such as graphite, MoS <sub>2</sub> ... shall not exceed 5 % by weight.	<b>Articulations and limit switches</b>  Penetrating or rust preventing grease with MoS <sub>2</sub> addition		
<b>ARAL</b>	<b>Aralub HL 2</b>	<b>Aralub HTR 2</b>			
<b>SHELL</b>	<b>Gadus S2 V220 2</b>				
<b>BP</b>	<b>Energrease LS 2</b>	<b>Energrease HTG</b>			
<b>MOBIL</b>	<b>Mobilux EP 2</b>				
<b>CASTROL</b>	<b>Olit 2 EP</b>	<b>Optitemp HT 2</b>	<b>Optimol-Spray EPL SHF</b>		
<b>Prinz-Schulte</b>		<b>Aero-Line MPG 1000 E</b>			
<b>ELKALUB</b>	<b>GLS 135/N2</b>	<b>GLS 962/N2</b>	<b>Elkalub-Spray FLC 367</b>	<b>GLL 10/N2</b>	
<b>DOW CORNING</b>				<b>Molykote Polygliss N</b>	
<b>BECHEM</b>	<b>HIGH-LUB L2</b>				

Translation of the  
**Original operation instructions**

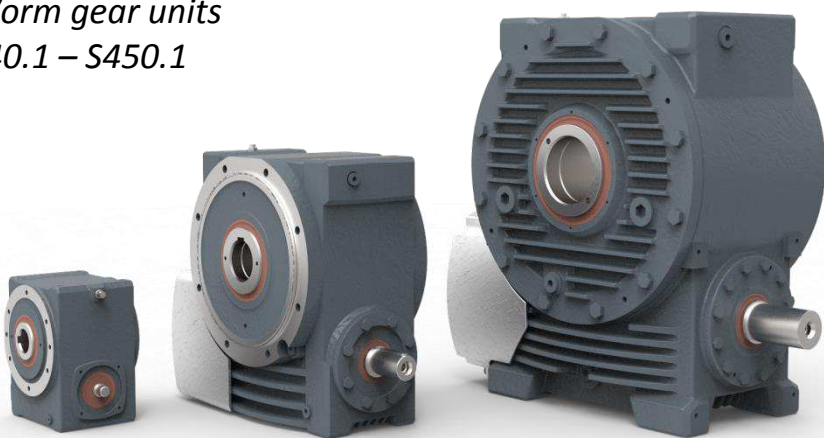
*Worm gear units*  
*S40.1 – S450.1*



## Operation instructions

Worm gear units

S40.1 – S450.1

## Table of contents

1.	Introduction .....	3
2.	Safety instructions .....	3
2.1.	Intended use .....	3
2.2.	Inappropriate or unintended use .....	4
2.3.	Warnings and notes, symbols and their signification .....	4
2.4.	Important instructions, basic duties, warranty and liability .....	4
3.	Technical description .....	5
3.1.	Design .....	6
3.2.	Name plate .....	7
3.3.	Technical data .....	8
3.3.1.	Service positions S40.1 – S80.1 .....	8
3.3.2.	Service positions S100.1 – S160.1 .....	9
3.3.3.	Service positions S200.1 – S450.1 .....	10
3.3.4.	Gear unit weight .....	11
3.3.5.	Lubricant .....	11
4.	Delivery, transport, handling & storage protection .....	13
4.1.	Delivery, transport, handling .....	13
4.2.	Storage and protection .....	14
5.	Assembly .....	15
5.1.	Gear unit assembly .....	15
5.1.1.	Gear unit with free shaft ends (at drive or output drive) .....	15
5.1.2.	Gear unit with hollow shaft at output drive (slip-on gear) .....	16
5.2.	Mounting the motor .....	17
6.	Commissioning .....	18
7.	Operation, malfunctions, causes, troubleshooting .....	19
8.	Servicing and maintenance .....	20
8.1.	Description of maintenance work .....	21
8.1.1.	Oil level and status monitoring .....	21
8.1.2.	Oil change .....	21
9.	Screw tightening torques .....	22
9.1.	Standard screw thread .....	22
9.2.	Screw plugs .....	22
10.	Spare parts .....	23
10.1.	Spare parts for sizes S40.1 - S80.1 .....	23
10.2.	Spare parts for sizes S100.1 – S160.1 .....	24
10.3.	Spare parts for sizes S200.1 - S450.1 .....	25
11.	Disposal .....	26
12.	Appendix I: Declaration of Incorporation .....	27

## **Operation instructions**

Worm gear units

S40.1 – S450.1

### **1. Introduction**

The present operation instructions are part of the scope of supply and should be stored, if possible, near the gear unit where it can easily be accessed. Installation, commissioning and maintenance work may only be performed by qualified personnel who have both read and understood these operation instructions. AUMA Drives shall not be held liable for any damage or failure incurred by non-observance of these instructions.

AUMA Drives worm gear units have been designed in accordance with recognised standards, directives and safety regulations and correspond to the technical status at the time of printing of these operation instructions. We reserve the right to perform technical alterations on the products.

### **2. Safety instructions**

#### **2.1. Intended use**

AUMA Drives worm gear units have been designed and developed in accordance with recognised standards, directives and safety regulations and are supplied ready to operate. Machinery Directive 2006/42/EC applies to AUMA Drives worm gear units. They are partly completed machinery which are to be installed into a machine. The required Declaration of Incorporation of Partly Completed Machinery is included in section 12 of these operation instructions. The machine manufacturer or the machine operator must ensure that all legal requirements, directives, guidelines, national regulations and recommendations with respect to assembly, commissioning and operation are met at the place of installation.

Installation, commissioning and maintenance work must be exclusively performed by qualified personnel. Qualified personnel are persons, who, because of their training, experiences and position as well as their knowledge of appropriate standards, regulations, health and safety requirements and working conditions, are authorised by the person responsible for the safety of the equipment to perform the required duties and are therefore aware of, and can report, possible hazards. (Definition of qualified employees according to IEC 364)

Drives worm gear units may only be operated within the limits and conditions defined in the delivery contract.

Intended use includes observance of the operation instructions or observance of the instructions and specifications included. Furthermore, fulfilment of the legal provisions on occupational health and safety and the prevention of accidents, as well as heeding of safety instructions and warning signs attached to the product to avoid both personal injuries and property damage.

## Operation instructions

Worm gear units  
S40.1 – S450.1

### 2.2. Inappropriate or unintended use

Any uses other than those indicated in section 2.1 are either inappropriate or unintended. AUMA Drives shall not assume any liability for personal injuries or property damage incurred from this use.

Inappropriate or unintended used includes among others:

- Use in potentially explosive atmosphere
- Use outside technically and contractually agreed limits (output speeds, power, torques, ambient conditions)

Improper use furthermore includes:

- Operation without oil filling or with lubricants other than those specified
- Opening the gear unit when installed. During the warranty period, gear units may only be opened with prior consent of the manufacturer, otherwise any warranty claim will be void.
- Any modifications on the gear unit and in particular those impairing operational safety and reliability

### 2.3. Warnings and notes, symbols and their signification



Symbol	Signification
	Indicates safety instructions which have to be observed to avoid personal injuries (injuries death).
	Indicates safety instructions which have to be observed to avoid damage at the gear unit.
	General instructions, hints.

Table 2.3: Warnings and symbols

### 2.4. Important instructions, basic duties, warranty and liability

- The machine manufacturer/operator have to ensure that the all specifications and instructions have been read, understood and heeded to:
  - avert threats to life or physical condition
  - ensure operational safety of the gear unit and
  - avoid both installation downtimes and damage to the environment
- The manufacturer of the equipment is obliged to include these operation instructions in the operation instructions of the equipment.
- The machine manufacturer/operation shall be held liable for expert installation (assembly), maintenance and operation of the AUMA Drives worm gear unit. This work may only be performed by qualified and trained personnel.
- Work always has to be performed while the gear unit is switched off and protected against accidental start-up (key switch, sign).
- In case of detected defects as well as for malfunctions such as increased noise levels, oil leakage, rising operating temperature, etc., the gear unit must be shut down immediately. All defects must be remedied before restarting the equipment.
- During the warranty period the gears may only be opened with AUMA Drives' consent.

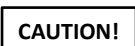
## Operation instructions

Worm gear units  
S40.1 – S450.1

- Spare parts must generally be ordered with AUMA Drives.
- Prior to using the gear unit, the data on the name plate has to be checked against that of the accompanying documents (delivery note, order acknowledgement, test report, etc.) for compliance.
- Welding at the gear unit is not permitted and the gear unit must not be used for protective earth connection.
- Revolving and rotating parts must be protected against accidental contact.
- The plant manufacturer or plant operator are responsible for implementing required protective measures on site, such as enclosures, barriers, or personal protective equipment for the staff.
- Under certain operation conditions, the surface temperature of the gear unit may rise up to 110°C. Danger of burns!
- Danger of burns due to hot oil when changing oil.
- Cleaning with a high pressure cleaner is not permitted.

Failure to observe the specifications indicated entails complete exclusion of liability and warranty expires. Consequential damage of inappropriate use can include property damage and personal injuries and even death.

### 3. Technical description

AUMA Drives gear units of the S.1 series are single-stage worm gear units. AUMA Drives gear units of the S.1 series are single-stage worm gear units, characterised by extremely low noise, high efficiency, utmost reliability and long service life.



**AUMA Drives worm gear units are generally not self-locking.**

Self-locking exists, if the start of the worm shaft is not possible in spite of the driving worm wheel. Internal impacts such as vibration may limit and under certain conditions even cancel the self-locking effect. Among others, self-locking depends on the transmission ratio (or the pitch angle of the splines), the lubricant as well as the operating and ambient temperatures. For actuation applications for which the self-locking effect is required, it should always be verified whether the installation of a return block or a brake is the more practical solution. An automatic self-locking gear unit cannot replace a brake. If self-locking is required, please contact AUMA Drives.

Section 3.1 provides a schematic description of the AUMA Drives worm gear unit design. Major sub-assemblies are designated.

### 3.1. Design

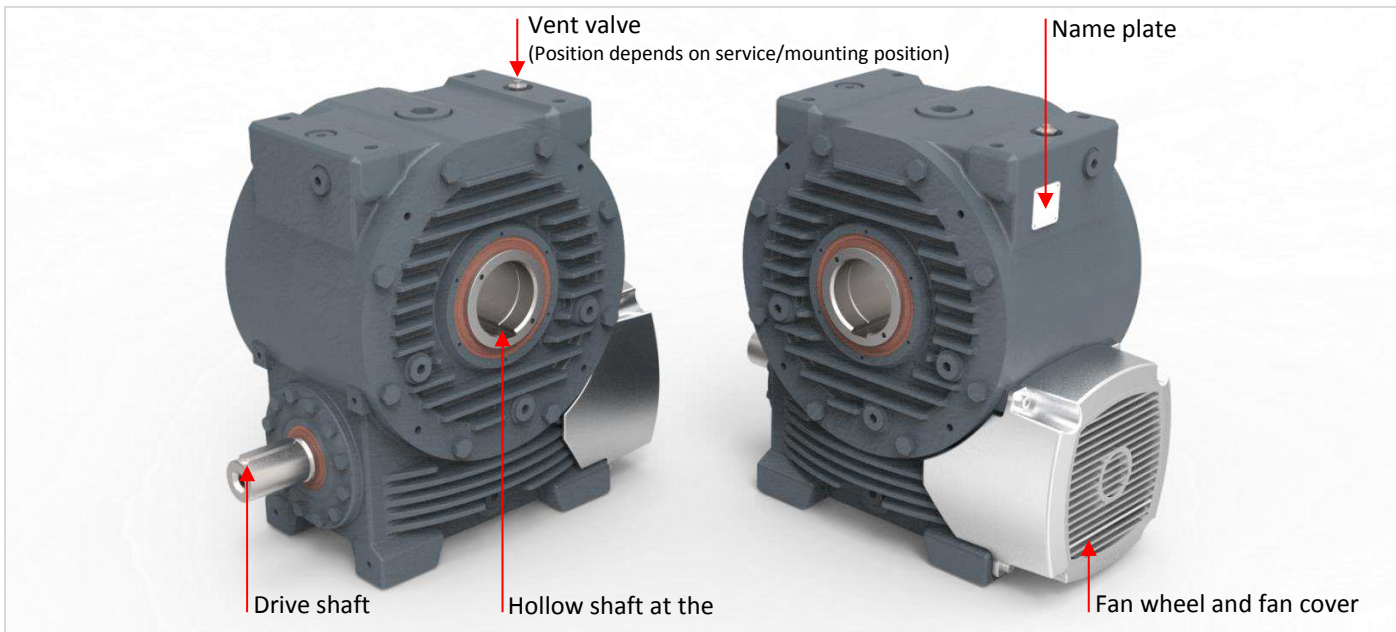

Fig. 3.1-1: Design of basic version (shaft at input, hollow shaft at output), using the example of S250.1 in service position B3



In addition to the basic versions, specific equipment for the plants such as flanges, output drive shafts, torque reaction levers, etc. are available as an option.

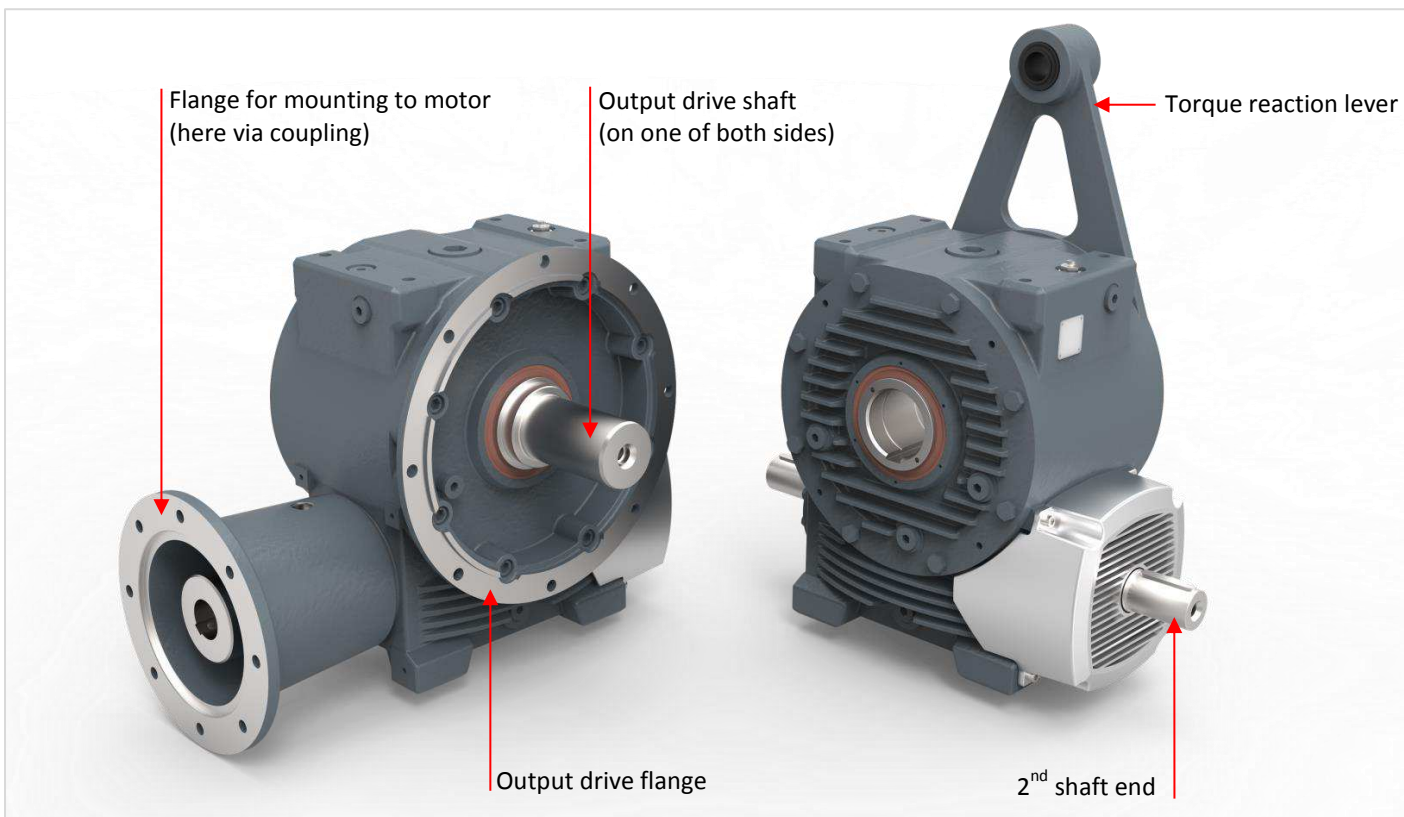

Fig. 3.1-2: Mounting options (extract), using the example of S250.1



## Operation instructions

Worm gear units

S40.1 – S450.1

### 3.2. Name plate

The following data is provided on the name plate attached to the gear unit.

The image shows three identical name plate templates for worm gear units. Each name plate is a rectangular box with a header section and a main data section. The data section contains fields for various technical specifications, with lines pointing to labels on the left and right sides. The bottom of each name plate features the text "Made in Germany".

**Name Plate 1 (Top):**

- Type/Size: Type: \_\_\_\_\_
- Serial number: No: \_\_\_\_\_ CO \_\_\_\_\_
- Delivery date [WWYY]: \_\_\_\_\_
- Max. output torque:  $T_{2max} =$  \_\_\_\_\_ Nm Ratio: \_\_\_\_\_
- Output speed:  $n_2 =$  \_\_\_\_\_ 1/min Temp.: \_\_\_\_\_
- Lubricant: Lub.: \_\_\_\_\_
- Customer item number: Item No.: \_\_\_\_\_ m= \_\_\_\_\_ kg
- Miscellaneous: \_\_\_\_\_
- Service position: \_\_\_\_\_
- AUMA Drives order number: \_\_\_\_\_
- Ratio: \_\_\_\_\_
- Ambient temperature: \_\_\_\_\_
- Lubricant quantity: \_\_\_\_\_
- Mass/Weight: \_\_\_\_\_
- Insulation class: \_\_\_\_\_

**Name Plate 2 (Middle):**

- Type/Size: Type: \_\_\_\_\_
- Serial number: No: \_\_\_\_\_ CO \_\_\_\_\_
- Delivery date [WWYY]: \_\_\_\_\_
- Rated output torque:  $T_2 =$  \_\_\_\_\_ Nm Ratio: \_\_\_\_\_
- Input speed:  $n_1 =$  \_\_\_\_\_ 1/min Temp.: \_\_\_\_\_
- Lubricant: Lub.: \_\_\_\_\_
- Customer item number: Item No.: \_\_\_\_\_ m= \_\_\_\_\_ kg
- Miscellaneous: \_\_\_\_\_
- Service position: \_\_\_\_\_
- AUMA Drives order number: \_\_\_\_\_
- Ratio: \_\_\_\_\_
- Ambient temperature: \_\_\_\_\_
- Lubricant quantity: \_\_\_\_\_
- Mass/Weight: \_\_\_\_\_
- Insulation class: \_\_\_\_\_

**Name Plate 3 (Bottom):**

- Type/Size: Type: \_\_\_\_\_
- Serial number: No: \_\_\_\_\_ CO \_\_\_\_\_
- Delivery date [WWYY]: \_\_\_\_\_
- Rated output torque:  $T_2 =$  \_\_\_\_\_ Nm Ratio: \_\_\_\_\_
- Input speed:  $n_1 =$  \_\_\_\_\_ 1/min Temp.: \_\_\_\_\_
- Lubricant: Lub.: \_\_\_\_\_
- Miscellaneous: \_\_\_\_\_ m= \_\_\_\_\_ kg
- Service position \_ insulation class: \_\_\_\_\_
- AUMA Drives order number: \_\_\_\_\_
- Ratio: \_\_\_\_\_
- Ambient temperature: \_\_\_\_\_
- Lubricant quantity: \_\_\_\_\_
- Mass/Weight: \_\_\_\_\_

## Operation instructions

Worm gear units  
S40.1 – S450.1

### 3.3. Technical data

#### 3.3.1. Service positions S40.1 – S80.1

The illustrations below show possible service positions and the pertaining positions of the vent valve and the oil draining screw plug. For the lubricant quantities required refer to table 3.3.5-2.





<p><b>B3</b></p>	<p>Horizontal output drive shaft Horizontal drive shaft - bottom</p> 	<p><b>B6</b></p>	<p>Horizontal output drive shaft Vertical drive shaft - bottom</p> 
<p><b>B8</b></p>	<p>Horizontal output drive shaft Horizontal drive shaft - top</p> 	<p><b>V5</b></p>	<p>Vertical output drive shaft - bottom Horizontal drive shaft</p> 
<p><b>B3I</b></p>	<p>Horizontal output drive shaft Vertical drive shaft - top</p> 	<p><b>V5II</b></p>	<p>Vertical output drive shaft - top Horizontal drive shaft</p> 
<p style="text-align: center;"> <span style="color: red;">●</span> Vent valve and oil filling      <span style="color: blue;">●</span> Oil drain         </p>			

Figure 3.3.1: Service positions S40.1-S80.1

## Operation instructions

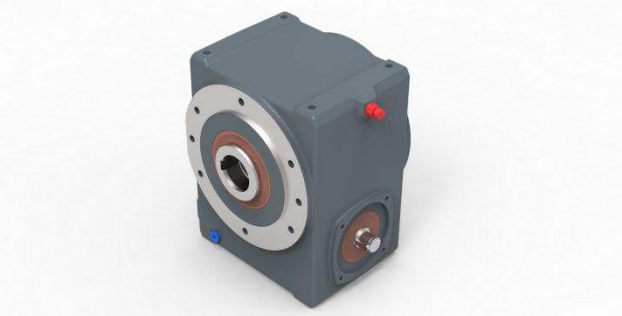
Worm gear units

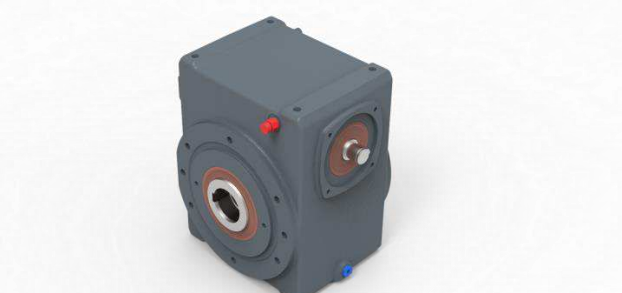
S40.1 – S450.1

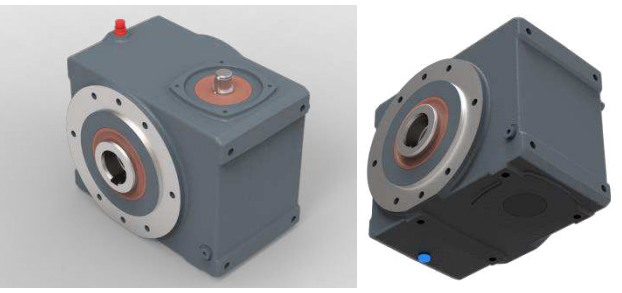
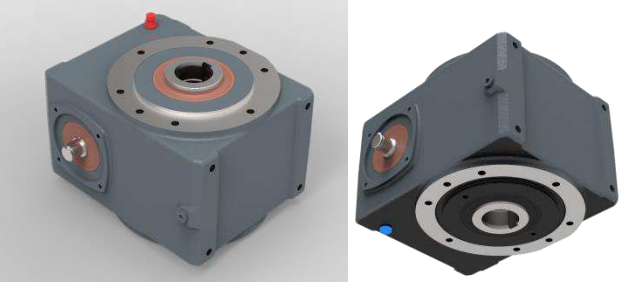
### 3.3.2. Service positions S100.1 – S160.1

The illustrations below show possible service positions and the pertaining positions of the vent valve, as well as the oil level checking and the oil draining screw plug. In some cases, an oil dipstick at the vent valve will take over the function of the oil level checking screw plug. For the lubricant quantities required refer to table 3.3.5-2.

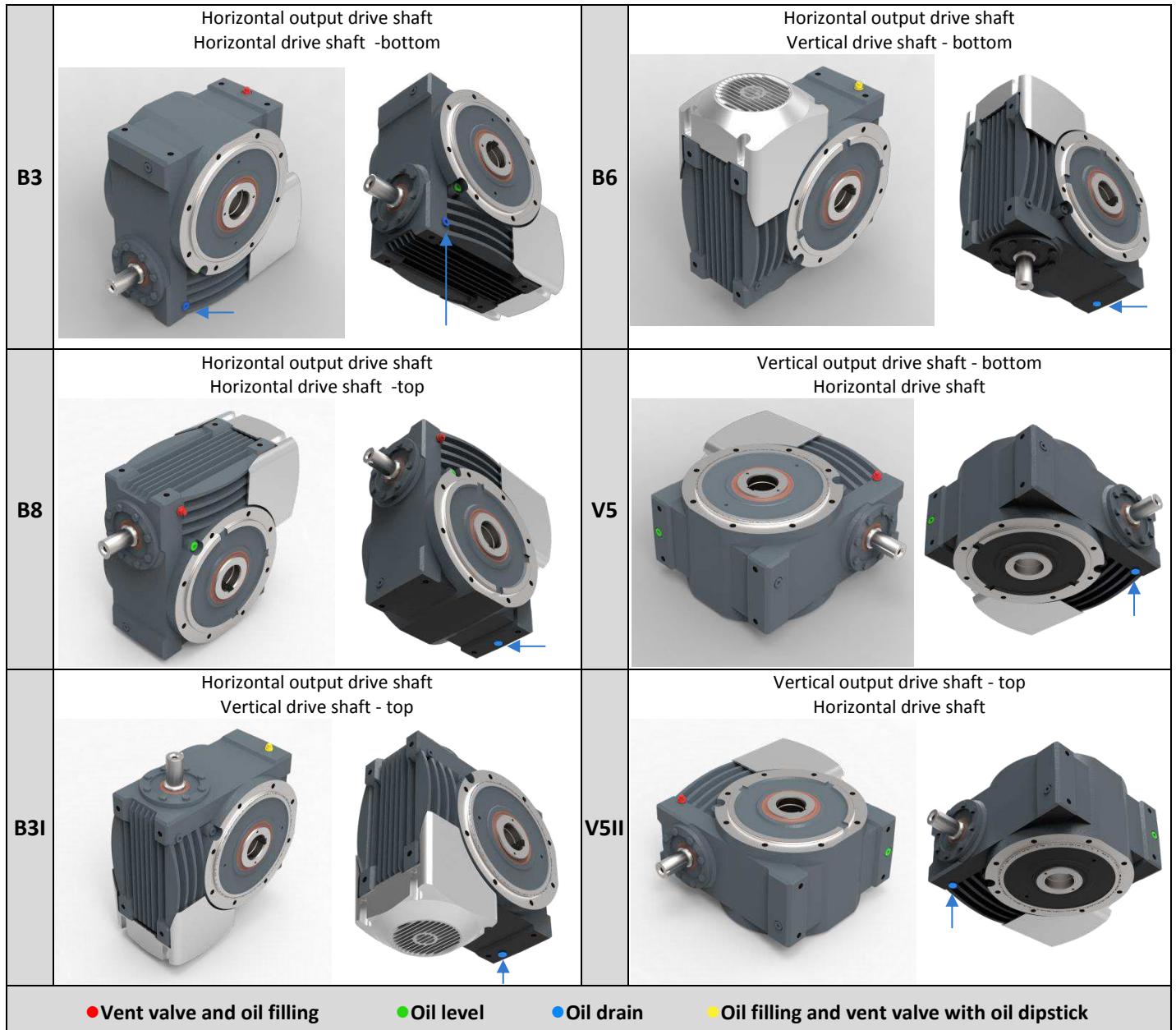

Fig. 3.3.2: Service positions S100.1-S160.1

**CAUTION!**

Depending on application and service conditions, an oil quantity or oil level different from the indications of these operation instructions may be required. For the pertaining information, refer to the contractual documents as well as to the name plate. In these cases, the position of the oil filling screw plug and the oil level checking screw plug may differ from this representation.

## Operation instructions

Worm gear units  
S40.1 – S450.1

### 3.3.3. Service positions S200.1 – S450.1

The illustrations below show possible service positions and the pertaining positions of the vent valve, as well as the oil level checking and the oil draining screw plug. For the lubricant quantities required refer to table 3.3.5-2.





<p><b>B3</b></p>	<p>Horizontal output drive shaft Horizontal drive shaft -bottom</p> 	<p><b>B6</b></p> <p>Horizontal output drive shaft Vertical drive shaft - bottom</p> 
<p><b>B8</b></p>	<p>Horizontal output drive shaft Horizontal drive shaft -top</p> 	<p><b>V5</b></p> <p>Vertical output drive shaft - bottom Horizontal drive shaft</p> 
<p><b>B31</b></p>	<p>Horizontal output drive shaft Vertical drive shaft - top</p> 	<p><b>V511</b></p> <p>Vertical output drive shaft - top Horizontal drive shaft</p> 
<p style="text-align: center;"> <span style="color: red;">●</span> Vent valve and oil filling                  <span style="color: green;">●</span> Oil level                  <span style="color: blue;">●</span> Oil drain         </p>		

Figure 3.3.3: Service positions S200.1-S450.1

**CAUTION!**

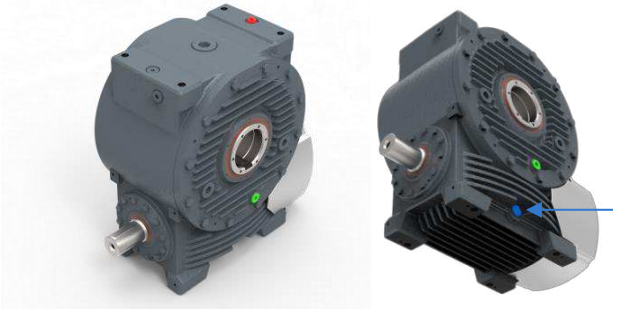
Depending on application and service conditions, an oil quantity or oil level different from the specifications of these operation instructions may be required. For the pertaining information, refer to the contractual documents (for example drawings) as well as to the name plate. In these cases, the position of the oil filling screw plug and the oil level checking screw plug may differ from this representation.

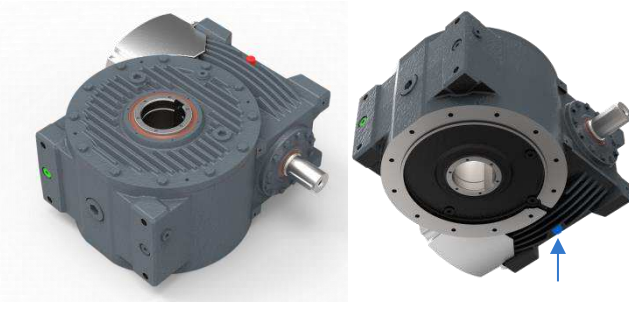
## Operation instructions

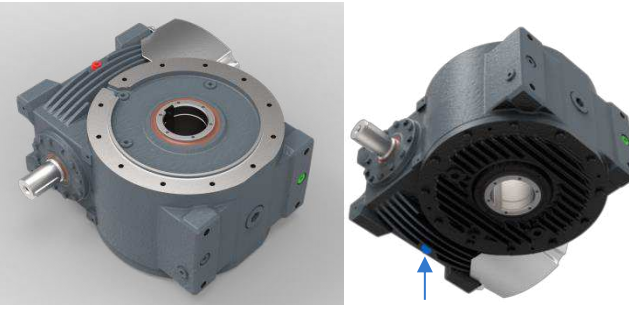
Worm gear units  
S40.1 – S450.1

### 3.3.4. Gear unit weight

The weights below does not include oil filling and are reference values. Casting tolerances as well as different transmission ratios and equipment variants result in different weights. Due to the large number of variants, complete representation of all equipment is not possible. For the weight of the configuration delivered, refer to the name plate (including oil).

Size	SVA basic version without oil [kg]
S40.1	5.2
S50.1	11.0
S63.1	14.5
S80.1	26
S100.1	46 <sup>1)</sup>
S125.1	84 <sup>1)</sup>
S160.1	157 <sup>1)</sup>
S200.1	210 <sup>1)</sup>

Table 3.3.4: Gear unit weights  
valve

Size	SVA basic version without oil [kg]
S225.1	336 <sup>1)</sup>
S250.1	380 <sup>1)</sup>
S280.1	525 <sup>1)</sup>
S315.1	700 <sup>1)</sup>
S355.1	960 <sup>1)</sup>
S400.1	1,300 <sup>1)</sup>
S450.1	1,710 <sup>1)</sup>

1) incl. vent

### 3.3.5. Lubricant

The splines of the AUMA Drives worm gear units are lubricated by splash lubrication. Unless agreed otherwise, the gear units are supplied with oil filling when leaving the factory. We use CLP-PG oils (according to DIN 51517-part 3) as standard. These fully synthetic oils (polyglycoles) have outstanding temperature-viscosity behaviour and excellent characteristics with regard to corrosion protection, resistance to ageing and wear reduction. For ambient temperatures between -10 °C and +40 °C, oils of ISO viscosity class VG460 must be used. For other ambient conditions, a suitable lubricant has to be selected by AUMA Drives. The table below lists lubricants by different manufacturers. The lubricant used is indicated on the name plate. Gear units without grease filling in the factory have a DIN compliant indication relating to the lubricant to be used and the required viscosity class.

Marking according to DIN 51517-3 and DIN 51519	Klüber	ARAL	Shell	Mobile	Bechem	Castrol
CLP PG / ISO VG 460	Klübersynth GH 6-460 <sup>(1)</sup>	Degol GS 460	Omala S4 WE 460	Glygoyle HE 460	Berusynth EP 460	Optiflex A 460

Table 3.3.5-1: Lubricants

1) Standard lubricants used in the factory

#### CAUTION!

**AUMA Drives can assume no warranty for the perfect suitability of all listed lubricants.**

 For certain applications, different lubricants (mineral oils, lubrication greases) can be used. Refer to the name plate or the contractual documents (e.g. drawings), for the actually used lubricant.

 Mixing oils of various classes, types and manufacturers is not permissible. Refer to the name plate for the lubricant actually used.

**Operation instructions**

Worm gear units

S40.1 – S450.1

**CAUTION!**

The table below shows the required oil quantities. These values are reference values. The filling level (of the cooled down oil) within the gear unit, defined by oil level screw plugs or markings (max. and min.) on the oil dipstick, is relevant - refer to sections 3.3.1 to 3.3.3

Size	Service position					
	B3	B8	B3I	B6	V5	V5II
S40.1	0.18	0.28	0.30	0.30	0.20	0.20
S50.1	0.45	0.75	0.65	0.65	0.55	0.55
S63.1	0.63	1.10	1.00	1.00	0.75	0.75
S80.1	1.30	2.50	2.00	2.00	1.50	1.50
S100.1	1.70	3.80	3.00	3.00	3.00	3.00
S125.1	2.00	6.50	4.00	4.00	4.00	4.00
S160.1	4.20	12.30	8.50	8.50	7.70	7.70
S200.1	8.00	22.00	15.00	15.00	13.50	13.50
S225.1	11.00	26.00	19.00	19.00	19.50	19.50
S250.1	14.00	42.50	29.00	29.00	29.00	29.00
S280.1	18.50	58.00	41.00	41.00	39.50	39.50
S315.1	27.00	75.00	53.00	53.00	53.00	53.00
S355.1	36.00	110.00	75.00	75.00	75.00	75.00
S400.1	44.00	148.00	98.00	98.00	98.00	98.00
S450.1	68.00	219.00	141.00	141.00	144.00	144.00

Table 3.3.5-2: Lubricant quantity

**CAUTION!**

Depending on application and service conditions, an oil quantity or oil level different from the specifications of these operation instructions may be required. For the pertaining information refer to the contractual documents and the name plate.



## Operation instructions

Worm gear units  
S40.1 – S450.1

### 4. Delivery, transport, handling & storage protection

#### 4.1. Delivery, transport, handling

Prior to delivery, all AUMA Drives worm gear units are subjected to final inspection and leave AUMA Drives in perfect condition and suitable packaged according to their destination. Upon receipt, the delivery has to be inspected for completeness and possible transport damage. Advise the forwarding company or the customer service of AUMA Drives of any possible defects. Commissioning the gear unit might not be permitted.

CAUTION!

All AUMA Drives worm gear units are supplied with screwed in vent valve. For some versions, the gear unit must always be stored and transported in service position (refer to Notes in sections 3.3.1 to 3.3.3). In this case, the gear units are marked with special notice signs.



#### Only use lifting appliances and load suspension equipment with sufficient bearing capacity for transport!

For the overall weight of the gear unit, refer to the name plate. Reference values can also be found in section 3.3.4. **The load is borne by two suitable eye bolts. Ensure that they have been firmly screwed to the housing. Fig. 4.1 shows the example of using the ring bolts for transport in service position B3. For other service positions, further threaded holes have been cut into the housing.**

CAUTION!

**The gear unit must not be handled via the threaded holes in the drive shafts and output drive shafts on the face side or the fan housing. Handle and transport with care to prevent damage. Hits and blows to the shaft ends might cause damage within the gear unit.**



Figure 4.1: Anchor points

Size	Thread size for transport eyebolts
S40.1	M6
S50.1-S63.1	M8
S80.1	M10
S100.1	M12
S125.1-S160.1	M16

Size	Thread size for transport eyebolts
S200.1	M20
S225.1-S250.1	M24
S280.1-S315.1	M30
S355.1-S450.1	M36

Table 4.1: Thread sizes for transport eyebolts

## Operation instructions

Worm gear units  
S40.1 – S450.1

### 4.2. Storage and protection

The storage or protection periods start immediately after delivery of the gear unit.

Unless agreed otherwise, AUMA Drives worm gear units are supplied with oil filling when leaving the factory. All inside parts are protected for 24 months. Inside parts of gear units supplied without oil filled are provided with corrosion protection sufficient for 12 months. Outer parts with metallic uncoated surface such as shaft ends, hollow shafts and mounting surfaces of flanges have been treated with corrosion protection, providing protection for six months. Once the period has expired, the corrosion protection has to be renewed.

CAUTION!

**Prior to assembly or installation remove corrosion protection agent from the outer parts using commercial cleaning agents. The cleaning agent must not come into contact with radial seals.**



**Ensure sufficient ventilation while removing the corrosion protection agent. Due to potentially explosive atmosphere, open fire is not permitted.**

The standard outer coating (finish coating based on polyurethane) provided in the factory is resistant to weak chemicals such as oils, resistant to mechanical impacts and temperature resistant up to 150 °C. Damage to the coating layers leads to failure of the corrosion protection and has to be touched up immediately. Sand blasting of the gear unit is not permitted.

The gear units should only be stored in closed and dry rooms. The impact of solvents, solvent vapours, fuels, acids, rubber solvents and other solvents should be avoided as well as exposure to direct sunlight, relative humidity >70% and major temperature fluctuations. The use of plastic film containing plasticizers is not recommendable.



**Gear units must be stored on levelled base plates, protected against vibration, and must not be stacked on top of each other.**



Should the storage locations or room be subject to major temperature fluctuations, should the relative humidity exceed 70% or gear units be stored for a longer period (>24 months), we recommend the following measures:

- Fill gear unit completely with oil (refer to table 3.3.5-1)
- Check oil quality (water contents) on a regular basis
- Seal gear units hermetically using VCI film and enclose water absorbing desiccants.
- Regular visual inspection of gear unit with regard to corrosion on the outer metallic uncoated parts
- Regular check of gear units for leakage on radial seals

CAUTION!

**After longer storage periods, the lubricant quality (refer to section 8.1.1) and the condition of the radial seals are to be checked prior to commissioning, and be replaced if required. Prevent any damage to the sealing ring seat on the shaft. Furthermore, the oil level must be checked (refer to section 8.1.1) and possibly be adjusted to the required filling level (refer also to table 3.3.5-2). When using other corrosion protection oils than those specified (table 3.3.5-2) for protection, thoroughly rinse gear unit prior to lubricant filling.**



## Operation instructions

Worm gear units  
S40.1 – S450.1

### 5. Assembly

#### 5.1. Gear unit assembly



The safety instructions in section 2 must be observed.

The following conditions must be met for installing the worm gear unit:

- These operation instructions were completely read and understood by the assembly personnel.
- Suitable lifting devices are available in sufficient quantity.
- The data on the name plate and the application must correspond to the contractually agreed values (transmission ratio, output speed, etc.)
- The gear unit must not be damaged
- Unless agreed otherwise, the ambient temperature must be between  $-10\text{ °C}$  and  $+40\text{ °C}$ .
- The environment of the installation site must be free of chemicals, acids, gases, etc. unless stipulated otherwise in the contractual documents.
- The gear unit must not be exposed to heat accumulation and waste heat from other devices.
- Vent valve (including oil dipstick) and oil draining screw plug must be freely accessible for maintenance work
- The corrosion protection agent must be removed from shaft ends and mounting faces (flanges).
- Machine frame:  
The machine frame must be designed to support the specified weights and torques so that no additional loads resulting from distortion or twisting can act on the gear unit. Ensure that all mounting faces are flush on the machine frame. Non-observance might cause damage on and within the gear unit.

Welding at the gear unit is not permitted and the gear unit must not be used for protective earth connection!



Should any questions or problems arise during installation, please contact the AUMA Drives service (for contact details refer to cover page of these operation instructions).

##### 5.1.1. Gear unit with free shaft ends (at drive or output drive)

CAUTION!

Gear units with free shaft end have to be placed on a suitable basis together with the drive. **The shafts must be aligned very carefully to ensure safe working conditions and low-noise operation. Avoid housing and shaft jamming. As an alternative, we recommend the use of elastic couplings and universal joints.** Gear units with output drive flange can directly be connected to the driven machine. However, mounting the gear unit to a solid basis at the same time is not possible. Use screws according to property class 8.8 to fasten the gear unit. All screws have to be fitted applying the required torque (refer to table 9.1).

When mounting couplings, observe the pertaining operation and mounting instructions of the coupling manufacturer. We recommend the use of flexible couplings to compensate for small inaccuracies in assembly. Couplings require static balancing at peripheral speeds of up to 20 m/s and dynamic balancing at peripheral speeds exceeding 20 m/s.

## Operation instructions

Worm gear units  
S40.1 – S450.1

CAUTION!

Consideration must be given to the permissible radial forces at the input shaft and output shaft ends when using rigid coupling units and elements which generate radial force, such as pulleys, toothed wheels, etc. The drive and output elements can be mounted by means of a fitting tool (refer to fig. 5.1.1) or by heating ( $\leq 120^{\circ}\text{C}$ ; wear heat-resistant gloves!) the appropriate part. **Do not under any circumstances attempt to mount by striking with a hammer as this would cause damage to the tooth profiles, roller bearings, housing, and shaft.** Prior to assembly, thoroughly clean gear shaft and holes of the drive or output drive element.



We recommend applying a corrosion protection agent (e.g. Gleitmo800 by Fuchs) to the shaft(s) of the gear unit to prevent tribocorrosion.

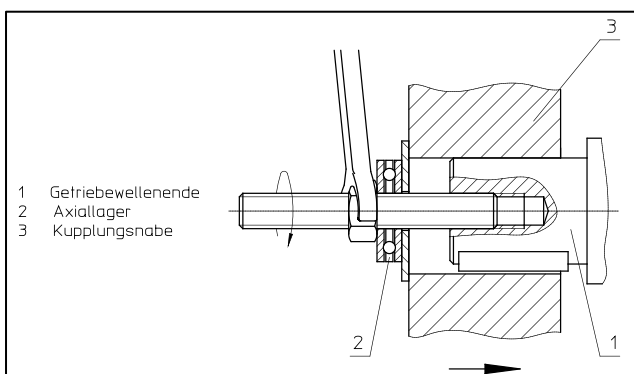

Figure 5.1.1: Fitting tool

### 5.1.2. Gear unit with hollow shaft at output drive (slip-on gear)

Gear unit with hollow shaft at the output drive can be placed directly on the shaft of the driven machine and be axially secured.

CAUTION!

For gear units fastened and axially secured via output drive flange, ensure that the machine side mounting face is perpendicular to the drive shaft to avoid distortion of gear unit and driven machine as well as resulting additional bearing loads. Use screws according to property class 8.8 to fasten the gear unit. All screws have to be fitted with the required torque (refer to table 9.1). Fastening the gear unit to the base plate while the machine shaft is located near the gear unit should by all means be avoided.

CAUTION!

For gear units whose reaction torque is not absorbed by flange but a torque reaction lever, we recommend installing the torque reaction lever on the driven machine side to avoid additional bending stress. Use screws according to property class 8.8 to fasten the torque reaction lever to the gear unit housing. All screws have to be fitted with the required torque (refer to table 9.1). We recommend using elastic sockets to protect against torque impulses and distortion. The fastening bolt should be fixed on both sides.

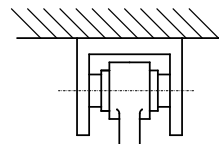

Axial securing of the gear unit on the shaft of the driven machine is either done via circlip and/or end disc with screw. Furthermore, shrink discs can also be used for axial positioning. Clamping screws may not be tightened without an inserted shaft as this can lead to plastic

## Operation instructions

Worm gear units  
S40.1 – S450.1

CAUTION!

**deformation in the hollow shaft. Heed the fitting instructions of the shrink disc manufacturer and observe the steps below:**

Mounting the shrink disc:

1. Remove spacers between the outer rings (if available)
2. Manually tighten screws slightly, so that the inner ring can still be turned.
3. Slightly grease the seat of the hub section for the shrink disc.
4. Carefully remove the grease from the hollow shaft hole and the driven machine shaft in the press section.
5. Fit shaft or slip-on gear on the driven machine shaft while fully using the shrink connection section.
6. Tighten clamping screws one after the other in clockwise direction but not crosswise. Several turns are required before reaching the required screw tightening torque.
7. The position between the solid shaft of the driven machine and the hollow shaft of the gear unit has to be marked to be able to detect a possible racing effect.

Dismounting the shrink disc:

1. Loosen clamping screws evenly one after the other to prevent the inner ring from jamming.
2. Loosen the flanges from the cone of the inner ring.
3. Dismount the shaft or pull off the slip-on gear from the driven machine.



We recommend applying a corrosion protection agent (e.g. Gleitmo800 by Fuchs) to the shaft of the driven machine to prevent tribocorrosion.

## 5.2. Mounting the motor

CAUTION!

**The motor is mounted using motor flange and coupling. We recommend using flexible couplings to compensate for small inaccuracies in assembly. When mounting couplings, observe the pertaining operation and mounting instructions of the coupling manufacturer. Use screws according to property class 8.8 to fasten the motor to the gear unit. All screws have to be fitted applying the required torque (refer to table 9.1).**

CAUTION!

**When mounting the motor via a hollow gear drive shaft, ensure that the motor shaft and the mounting faces of the motor flange are perpendicular to avoid distortion and the resulting bearing load. For this reason, AUMA Drives recommend motors whose design and position tolerance are reduced by 50 % in accordance with table 3 of EN 50347:2001. Prior to assembly, both motor shaft and hollow bore of the gear input shaft must be thoroughly cleaned. Use suitable anti-seizing compound (e.g. Gleitmo800 by Fuchs) to prevent friction corrosion. Use screws according to property class 8.8 to fasten the motor to the gear unit. All screws have to be fitted applying the required torque (refer to table 9.1).**

CAUTION!

**Do not apply hammer blows for assembly. This might damage the splines, roller bearings and the shafts.**



Heed operation instructions of the motor manufacturer for electrical connection!

## Operation instructions

Worm gear units  
S40.1 – S450.1

### 6. Commissioning



The safety instructions in section 2 must be observed.



**Commissioning of the gear unit is only permitted once the machine manufacturer/operator have integrated the gear unit in the machine, when complying with product specific European directives by affixing the CE mark on the machine and after confirming the safety of the system put on the market.**

#### CAUTION!

**Prior to and during commissioning, the following steps have to be performed:**

- In compliance with statutory requirements, revolving and rotating parts must be protected against accidental contact.
- Check vent valve for clogging or contamination, e.g. by paint residues. During operation, insufficient or insecure ventilation generates increased internal pressure and finally results in leakage.
- Check oil filling level → section 8.1.1
- Check oil quality → section 8.1.1
- Check radial seal
- Check tightening torques of the fastening screws  
Screws that can no longer be used have to be replaced by new ones of the same property class and type.
- During test run, check for unusual noise and vibration, formation of smoke or vapour as well as to the service temperature (gear unit surface up to approx. 70 °C).



AUMA Drives worm gear units achieve their full performance and optimum efficiency in well run-in condition and at service temperature. We recommend running in each gear unit with no load for some time first and then at approx. 50% of the rated load for several hours. If operation at partial load is not possible, the gear should be repeatedly stopped and cooled down once an oil temperature of approx. 80 – 90°C is reached. During running in, check for unusual noise and vibration, formation of smoke or vapour as well as to the service temperature (gear unit surface up to approx. 70 °C). Gear units to be operated in both directions should be run in in both directions of rotation. After running in, check gear unit for leakage.

## Operation instructions

Worm gear units  
S40.1 – S450.1

### 7. Operation, malfunctions, causes, troubleshooting

Gear units must be monitored during operation. Special attention should be paid to unusual running noise, increased service temperatures and possible oil leakage.

#### CAUTION!

**In case of irregularities and when eliminating malfunctions, the gear unit must be shut down immediately and the safety instructions of section 2.4 have to be observed. The equipment has to be protected against accidental start-up.**



During the warranty period, maintenance work may exclusively be carried out by AUMA Drives. If malfunctions occurring at a later date cannot be located or the effort required for repair would be excessive, please contact the AUMA Drives service technicians.

Fault	Possible causes	Remedy
Unusual running noise/vibration	<ul style="list-style-type: none"><li>• Damage to splines or bearing</li><li>• Changed bearing backlash</li><li>• Oil level too low</li></ul>	<ul style="list-style-type: none"><li>• Please contact AUMA Drives service</li><li>• Please contact AUMA Drives service</li><li>• Refill oil and check gear unit for leakage</li></ul>
Unusual blows/vibration	<ul style="list-style-type: none"><li>• Defective motor coupling</li><li>• Gear support worked loose</li></ul>	<ul style="list-style-type: none"><li>• Replace coupling</li><li>• Tighten fastening screws according to section 5.1</li></ul>
Increased service temperature	<ul style="list-style-type: none"><li>• Heat accumulation and /or waste heat from other devices</li><li>• Oil level too low</li><li>• Outdated/contaminated oil</li><li>• Impaired passive cooling</li></ul>	<ul style="list-style-type: none"><li>• Please contact AUMA Drives service</li><li>• Check oil level at room temperature and check in accordance with section 3.3.5, if applicable</li><li>• Change oil</li><li>• Clean both housing surface and fan cover</li></ul>
Oil leaks at gear unit	<ul style="list-style-type: none"><li>• Damaged radial seals</li><li>• Clogged vent valve</li></ul>	<ul style="list-style-type: none"><li>• Contact AUMA Drives service and replace radial seal</li><li>• Clean vent valve (refer to table 8) Vent valve are pressure relief valves. They open to the outside at approx. 0.3 bar and protect the gear unit against excessive internal pressure and possible leakage.</li></ul>
Oil leaks at vent valve (oil infeed)	<ul style="list-style-type: none"><li>• Incorrect service position</li><li>• Oil level too high</li><li>• Wrong lubricant (foam formation)</li></ul>	<ul style="list-style-type: none"><li>• Correct service position in accordance with section 3.3</li><li>• Check oil level at room temperature and check in accordance with section 3.3.5, if applicable</li><li>• Change oil, refer to section 8.1.2</li></ul>
Oil leaks at screw plugs (oil drain)	<ul style="list-style-type: none"><li>• Screw plugs not properly fastened</li></ul>	<ul style="list-style-type: none"><li>• Check radial seals and tighten screw plugs according to table 8.1.1</li></ul>

Table 7: Malfunctions- causes-remedy

## Operation instructions

Worm gear units  
S40.1 – S450.1

### 8. Servicing and maintenance

AUMA Drives gear units will reliably operate for several years in nominal operation. However, regular checks, cleaning and maintenance are recommended after commissioning.



The stipulated inspection intervals (table 8) mentioned above are part of the conditions of warranty.

All service work may only be performed by qualified and trained personnel.



**Work on the gear unit always has to be performed while the gear unit is switched off and protected against accidental start-up (key switch, sign).**

**CAUTION!**

**Only use original AUMA Drives spare parts for repair and maintenance tasks; otherwise a safe function of the gear unit cannot be guaranteed. All warranty and liability claims are void if the maintenance work has not been carried out correctly or if unapproved spare parts have been used.**

Measure	Maintenance interval	Remarks/notes
Check gear temperature	Every 3 months	Max. permissible temperature at housing: 110°C In case of higher temperatures, refer to section 7.
Check running noise	Every 3 months	In case of changes, refer to section 7.
Check oil level	Every 3 months	Refer to sections 8.1.1 and 3.3.5
Check oil quality	Every 3 months	Refer to sections 8.1.1 and 3.3.5
Check gear unit for tightness	Every 3 months	
Visual inspection of painting	Every 3 months	Damage to the coating of the outer gear unit parts leads to failure of the corrosion protection and has to be touched up immediately.
Clean vent valve	Every 3 months	Clean unscrewed vent valve with petroleum ether and dry or blow with compressed air. Ensure sufficient ventilation (explosion hazard)!
First oil change	After 2,000 operation hours	Refer to section 8.1.2
Further oil changes	After further 15,000 operating hours or 60 months	Refer to section 8.1.2
Clean gear unit	Every 12 months	Excessive water pressure and concentrated cleaning agents are not permitted for eliminating possible contamination.
Check fastening screws for tight fit	Every 12 months	Refer to section 5

Table 8: Corrective action and intervals

**CAUTION!**

**The indications on oil change intervals only apply to polyglycoles according to section 3.3.5. Depending on the application and the service conditions, other lubricants with different maintenance intervals can be used in some cases. For information, refer to contractual documents (e.g. drawings) or contact AUMA Drives service.**

## Operation instructions

Worm gear units  
S40.1 – S450.1

### 8.1. Description of maintenance work

#### 8.1.1. Oil level and status monitoring



**Oil and oil filling level may only be checked once gear unit has cooled down and is at standstill.**

##### Checking the lubricant status:

Open screw plug at oil drain (for position, refer to section 3.1) and drain a small quantity. Once the lubricant has been drained, seal oil drain according to specified tightening torque (table 8.1.1) (Caution: Fit sealing ring again!). Check oil quality with regard to colour and for the quality of solid particles or contamination contained.



If required, an external service or laboratory shall perform the quality checks. Lubricant manufacturers also offer these tests. If required, change oil (refer to section 8.1.2).

##### Oil level monitoring:

Remove vent valve with oil dipstick (refer to section 3.1), unscrew and wipe remaining oil of the oil dipstick. The oil can only be read off again, once the vent valve has been completely screwed in and removed again (refer to section 3.3.5). Check oil level in case of deviations.



Exclusively use lubricant of the same type (refer to name plate!) for refilling. Mixing oils of various types and manufacturers is not permissible (for selection, refer to table 3.3.5-1). Mineral oils in particular must not be used without prior explicit approval by AUMA Drives.

Finally, the vent valve has to be screwed in again, refer to tables 8.1.1 and 9.2 for the required tightening torque. Replace damaged sealing rings.

Size	Width across flats of the vent valve (oil infeed) [mm]	Tightening torque of the vent valve (oil infeed) [Nm]	Width of hexagon socket of the screw plug at the oil drain [mm]	Tightening torque of screw plug at the oil drain [Nm]
S40.1-S80.1	12	10	5	10
S100.1-S125.1	13	20	6	20
S160.1	17	34	8	34
S200.1-S355.1	24	85	12	85
S200.1-S450.1	27	130	17	130

Table 8.1.1: Tightening torques of screw plugs and vent valve

#### 8.1.2. Oil change

Oil change has to be performed shortly after shut-down while still **at service temperature** (housing surface is hand warm). Otherwise complete draining cannot be ensured due to lack of viscosity.



**Heat resistant gloves must imperatively be worn to avoid burns due to hot draining oil!**

1. Place collecting basin underneath the oil draining screw plug.
2. Unscrew oil draining screw plug and vent valve.

## Operation instructions

Worm gear units  
S40.1 – S450.1

3. Drain oil completely. If required, rinse gear unit with low-viscosity (and compatible) oil.  
Possible bronze flakes are uncritical.
4. Seal oil drain: Tighten oil drain screw plug and sealing ring with tightening torque according to tables 8.1.1 and 9.2 .
5. Refill new oil (refer to section 3.3.5) via threaded hole of vent valve up to required filling level (refer to section 8.1.1 "Oil level monitoring").
6. Screw in vent valve including oil dipstick (for tightening torque, refer to table 8.1.1 and 9.2)
7. Contain spilled oil using a suitable agent and dispose of used oil according to national regulations.

## 9. Screw tightening torques

### 9.1. Standard screw thread

Fastening screw	Tightening torque [Nm]		
	8.8	10.9	12.9
M4	3.1	4.5	5.25
M5	6.1	9	10.4
M6	11	15	18
M8	25	37	43
M10	51	75	87
M12	87	128	150
M16	214	314	365
M20	431	615	710
M24	742	1057	1220
M30	1489	2121	2450
M36	2594	3695	4280

Table 9.1: Tightening torques for standard thread screws

### 9.2. Screw plugs

Screw plug St		Tightening torque [Nm]	Screw plug St		Tightening torque [Nm]
Metric fine thread in accordance with DIN 13	Pipe threads in accordance with EN ISO 228		Metric fine thread in accordance with DIN 13	Pipe threads in accordance with EN ISO 228	
M10 x 1.0	-	10	-	G 1/2	60
-	G 1/8 A	10	M22 x1.5	-	60
M12 x 1.5	-	20	M26 x 1.5	-	70
-	G 1/4 A	26	M27 x 2.0	-	85
M14 x 1.5	-	30	-	G 3/4 A	85
M16 x 1.5	-	34	M33 x 2.0	-	130
-	G 3/8 A	34	-	G 1 A	130
M18 x 1,5	-	42	M48 x 1.5	G 1 1/2 A	150
M20 x 1.5	-	50	M60 x 2.0	G 2 A	170

Table 9.2: Tightening torques for screw plugs



## Operation instructions

Worm gear units  
S40.1 – S450.1

### 10. Spare parts

**CAUTION!**

Only use original spare parts by AUMA Drives for maintenance work! AUMA Drives will not assume any liability or warranty for damage incurred when using non-AUMA Drives spare parts. Furthermore, use of such products might impair the both characteristics and operational reliability and safety of the gear unit.

#### 10.1. Spare parts for sizes S40.1 - S80.1

The spare parts indicated below are only valid for the basic version with shaft at drive, hollow shaft at output drive, passive fan and service position B3. Deviating versions, service conditions and gear units for special application and ambient conditions require other components. Please indicate the order number or serial number of the gear unit (refer to name plate) when ordering spare parts.

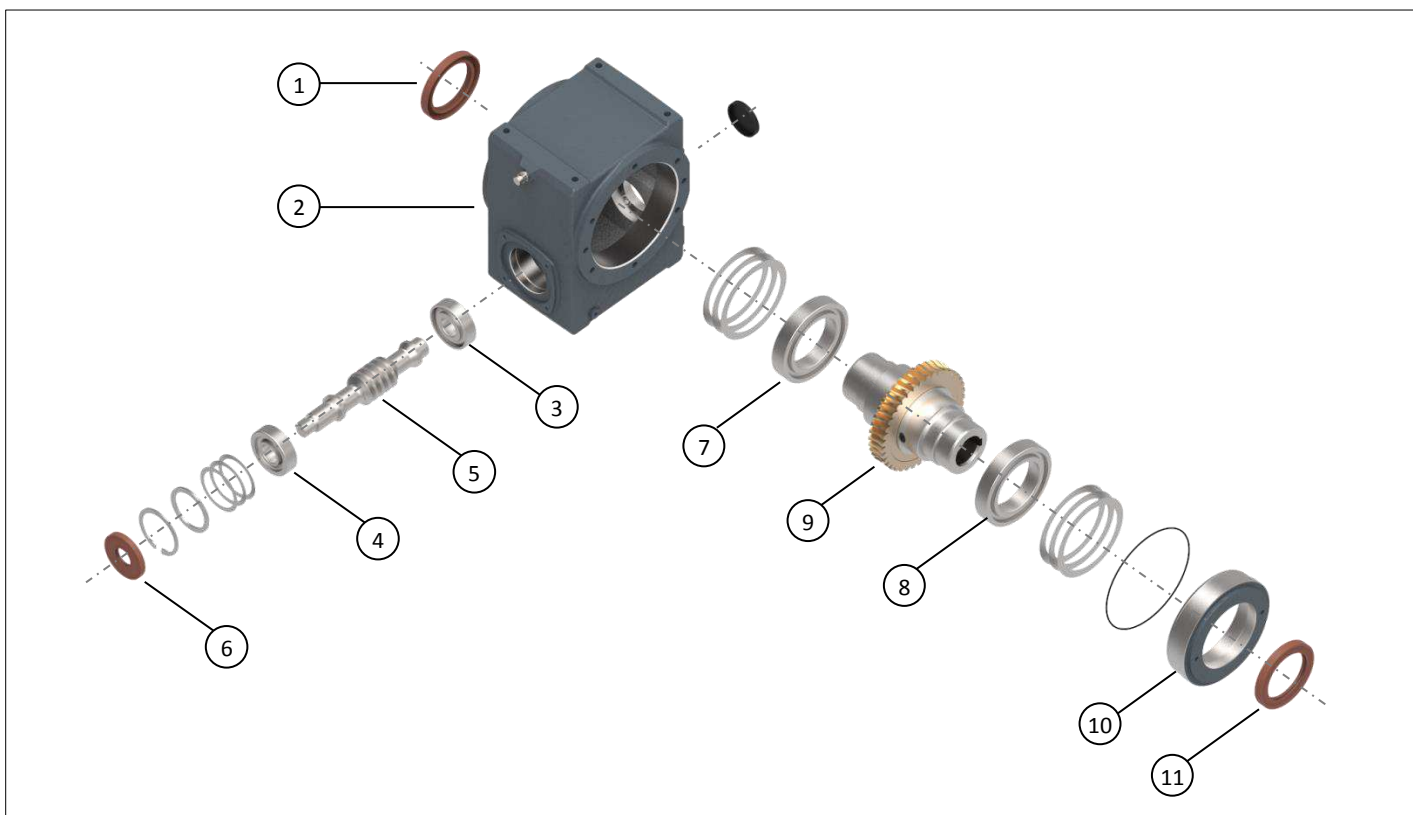

Fig. 10.1: Exploded view of sizes S63.1 and S80.1 (deviating design without bearing cover SR for sizes S40.1 and S50.1!)

No.	Spare part designation	S40.1	S50.1	S63.1	S80.1
1	Radial seal DIN3760-	AS35x52x7-FPG	AS50x72x8-FPG	AS50x72x8-FPG	AS65x90x10-FPG
2	Housing				
3	Ball bearing	DIN720-32004X-J	DIN720-32005X-J <sup>(1)</sup> DIN628-7204-B-TN <sup>(2)</sup>	DIN720-30205X-J <sup>(1)</sup> DIN628-7304-B-TN <sup>(2)</sup>	DIN720-31305X-J <sup>(1)</sup> DIN628-7305-B-TN <sup>(2)</sup>
4	Ball bearing	DIN720-30203-J	DIN720-32005X-J DIN628-7204-B-TN	DIN720-30205X-J DIN628-7304-B-TN	DIN720-31305X-J DIN628-7305-B-TN
5	Worm shaft				
6	Radial seal DIN3760-	AS20x42x7-FPG	AS20x47x7-FPG	AS20x52x8-FPG	AS25x62x7-FPG
7	Deep groove ball bearing DIN625-	16007-J	6010-J	6011-J	6014-J
8	Deep groove ball bearing DIN625-	16008-J	6011-J	6011-J	6014-J
9	Worm wheel				
10	Bearing cover SR	<i>n/a</i>	<i>n/a</i>		
11	Radial seal DIN3760-	AS40x68x8-FPG	AS50x90x10-FPG	AS50x72x8-FPG	AS65x90x10-FPG

Table 10.1: Wear parts S40.1-S80.1

<sup>(1)</sup> for i=12.75 (13); 25 (25.5); 51 (53); 61 (62); 82 (83)

<sup>(2)</sup> for i=5 (4.83); 7.5 (7.25); 10 (9.5 & 9.75); 15 (14.5); 20 (19 & 19.5); 30 (29); 40 (38 & 39)

## Operation instructions

Worm gear units  
S40.1 – S450.1

### 10.2. Spare parts for sizes S100.1 – S160.1

The spare parts indicated below are only valid for the basic version with shaft at drive, hollow shaft at output drive, passive fan and service position B3. Deviating versions, service conditions and gear units for special application and ambient conditions require other components. Please indicate the order number or serial number of the gear unit (refer to name plate) when ordering spare parts.

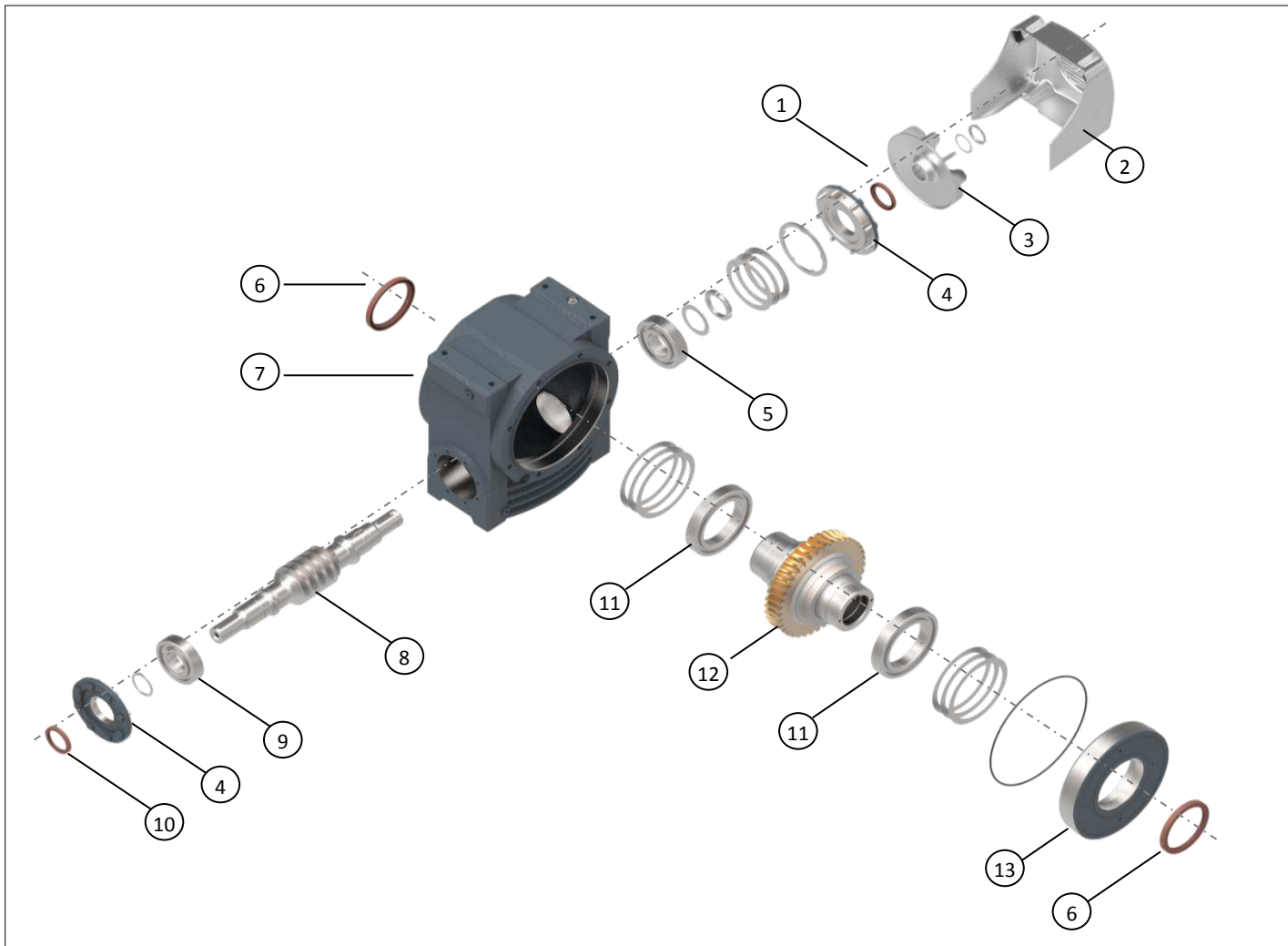

Fig. 10.2: Exploded view of sizes S100.1 – S160.1

No.	Spare part designation	S100.1	S125.1	S160.1
1	Radial seal DIN3760-	AS35x62x12-70...80FPM	AS42x72x8-FKM-G	AS55x72x8-FP-G
2	Fan cover			
3	Fan wheel			
4	Bearing cover SW			
5	Angular ball bearing DIN628-	QJ 308-TN	QJ 309-TN	QJ 312-PHAS
6	Radial seal DIN3760-	AS85x110x12—FP-G	AS95x120x10-FPM-G	AS115x140x12-FP-G
7	Housing			
8	Worm shaft			
9	Deep groove ball bearing DIN625-	6308-J	6309-J	6311-J
10	Radial seal DIN3760-	AS35x62x12-70...80FPM	AS45x72x8-FKM-G	AS55x72x8-FP-G
11	Deep groove ball bearing DIN625-	6017-J	6020-J	6024-J
12	Worm wheel			
13	Bearing cover SR			

Table 10.2: Wear parts S100.1-S160.1

## Operation instructions

Worm gear units  
S40.1 – S450.1

### 10.3. Spare parts for sizes S200.1 - S450.1

The spare parts indicated below are only valid for the basic version with shaft at drive, hollow shaft at output drive, passive fan and service position B3. Deviating versions, service conditions and gear units for special application and ambient conditions require other components. Please indicate the order number or serial number of the gear unit (refer to name plate) when ordering spare parts.

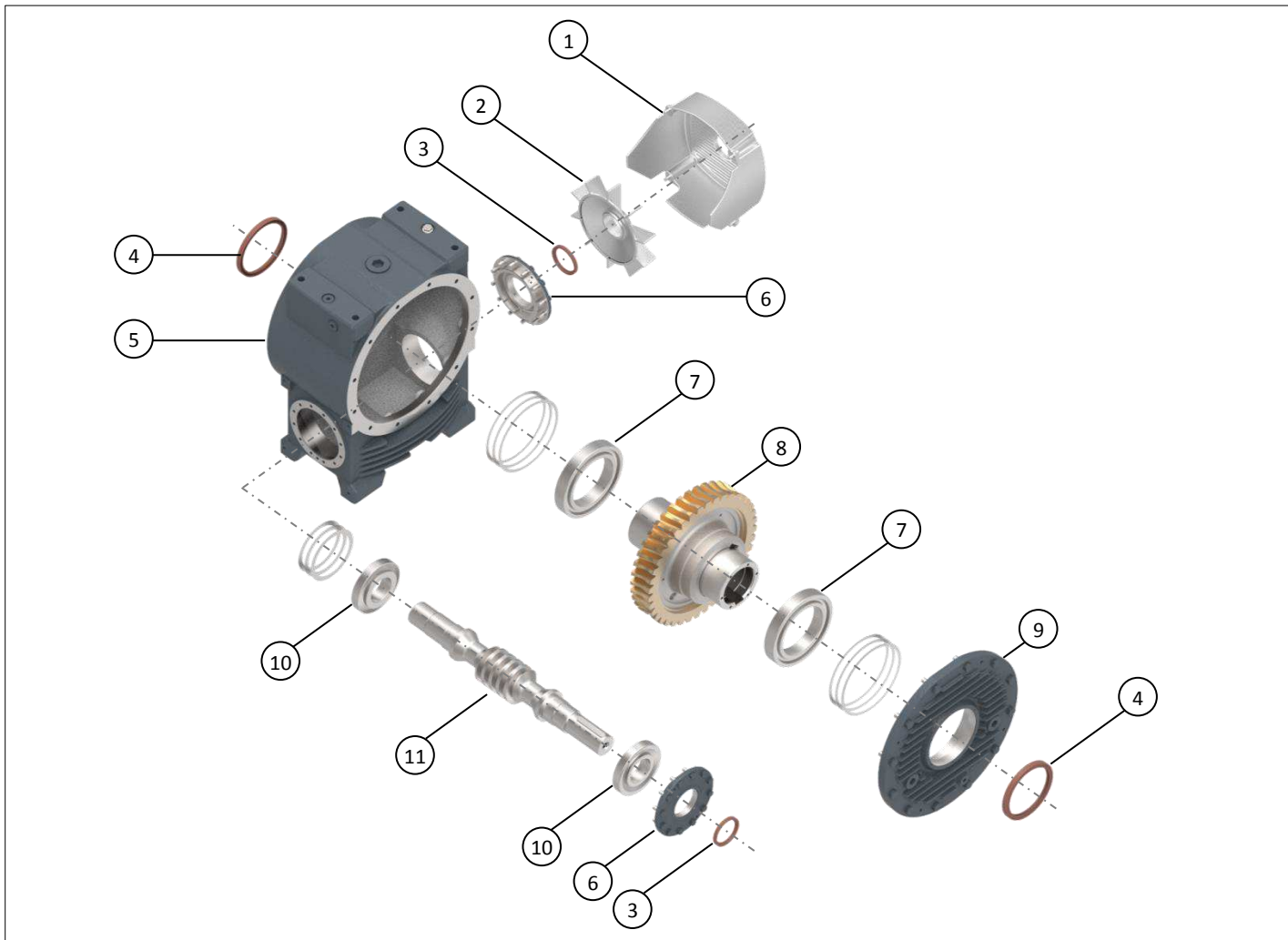

Fig. 10.3: Exploded view of sizes S200.1 - S450.1

No.	Spare part designation	S200.1	S225.1	S250.1	S280.1	S315.1	S355.1	S400.1	S450.1
1	Fan cover								
2	Fan wheel								
3	Radial seal DIN3760-	AS60x85x8- FKM-G	AS75x95x10- FKM-G	AS75x95x10- FKM-G	AS85x120x12- FKM-G	AS95x120x12- FKM-G	AS95x120x12- FKM-G	AS105x140x 12-FKM-G	AS115x140x 12-FKM-G
4	Radial seal DIN3760-	AS130x160x 12-FKM-G	AS160x190x 15-FKM-G	AS160x190x 15-FKM-G	AS180x210x 15-FKM-G	AS200x230x 15-FKM-G	AS220x250x 15-FKM-G	AS260x300x 20-FKM-G	AS280x320x 20-FKM-G
5	Housing								
6	Bearing cover SW								
7	Deep groove ball bearing DIN625-	6026-J	6032-J	6032-J	6036	6040-J	6044-M	6052-M	6056-M
8	Worm wheel								
9	Bearing cover SR								
10	Tapered roller bearings DIN720-	31313-J	31316-J	31316-J	31320X-J	31320X-J	31320X-J	31322X-J	31324X-J
11	Worm shaft								

Table 10.3: Wear parts S200.1-S450.1

## Operation instructions

Worm gear units

S40.1 – S450.1

### 11. Disposal

Our gear units have a long service life. However, they have to be replaced at one point in time. Individual components have to be disposed of as follows:



- Housing parts, worm shaft, shafts and roller bearings are to be disposed of as scrap steel
- Parts made of cast iron are also to be handled as scrap steel, in case there is no separate collection.
- Worm wheels made of bronze have to be disposed of separately.
- Greases and oils are hazardous to water and must not be released into the environment. They have to be collected and disposed of according to the relevant environmental provisions (national regulations for waste disposal and directives, e.g. ISO 14001).

## Operation instructions

Worm gear units

S40.1 – S450.1

## 12. Appendix I: Declaration of Incorporation



Drives

AUMA Drives GmbH  
Grenzstraße 5  
D-01640 Coswig  
www.auma-drives.com

Tel. +49 3523 94 60  
Fax +49 3523 74 675  
info@auma-drives.com

### EC Declaration of Incorporation

according to EC machinery directive 2006/42/EC dated 17 May 2006, appendix II B

The manufacturer

**AUMA Drives GmbH**  
**Grenzstraße 5**  
**D-01640 Coswig/ Germany**

declare herewith that the above mentioned gear units comply in their conception and design as well as in the versions distributed with the basic requirements for safety and health of the EC Directive 2006/42/EC, considering particularly appendix 1, paragraphs 1.1.2, 1.1.3, 1.1.5, 1.3.1, 1.3.7, 1.7.1., 1.7.3, 1.7.4.

With regard to the partly finished machine, the manufacturer commits to submitting the documents to the competent national authority via electronic transmission upon reasonable request. The relevant technical documentation pertaining to the partly completed machinery described in Annex VII, part B has been prepared.

The partly finished machine must not be put into service until the machinery into which the AUMA Drives unit is to be incorporated has been declared in conformity with the provisions of the EC Directive (2006/42/EC).

**Description of the partly finished machinery:**

Worm gear units  
Spur gear units  
Worm-spur gear units  
Spur-worm gear units  
Double worm gear units  
Slewing gear units  
Screw jacks  
Cross-helical gears  
Bevel gearboxes  
Planetary gear

**Applied harmonised standards:**

DIN EN ISO 12100:2011 Safety of machinery  
General principles for design - Risk assessment and risk reduction

**Authorised person for technical documentation:**

Michael Eleser, Grenzstraße 5, D-01640 Coswig

Coswig  
Ort

2015-10-01  
Date

  
Jürgen Riester, Managing Director

Y050.082/EN

This declaration does not contain any guarantees. The safety instructions in product documentation supplied with the devices must be observed. Non-concerted modification of the device components voids this declaration.

Ersatzteilliste  
List of spare parts

Schneckengetriebe / Worm Gearbox

Product Management

BHS Artikelnummer / Item no.	Zeichnung / Drawing
920009454	SOG180-0016-A
920009455	SOG180-0017-A

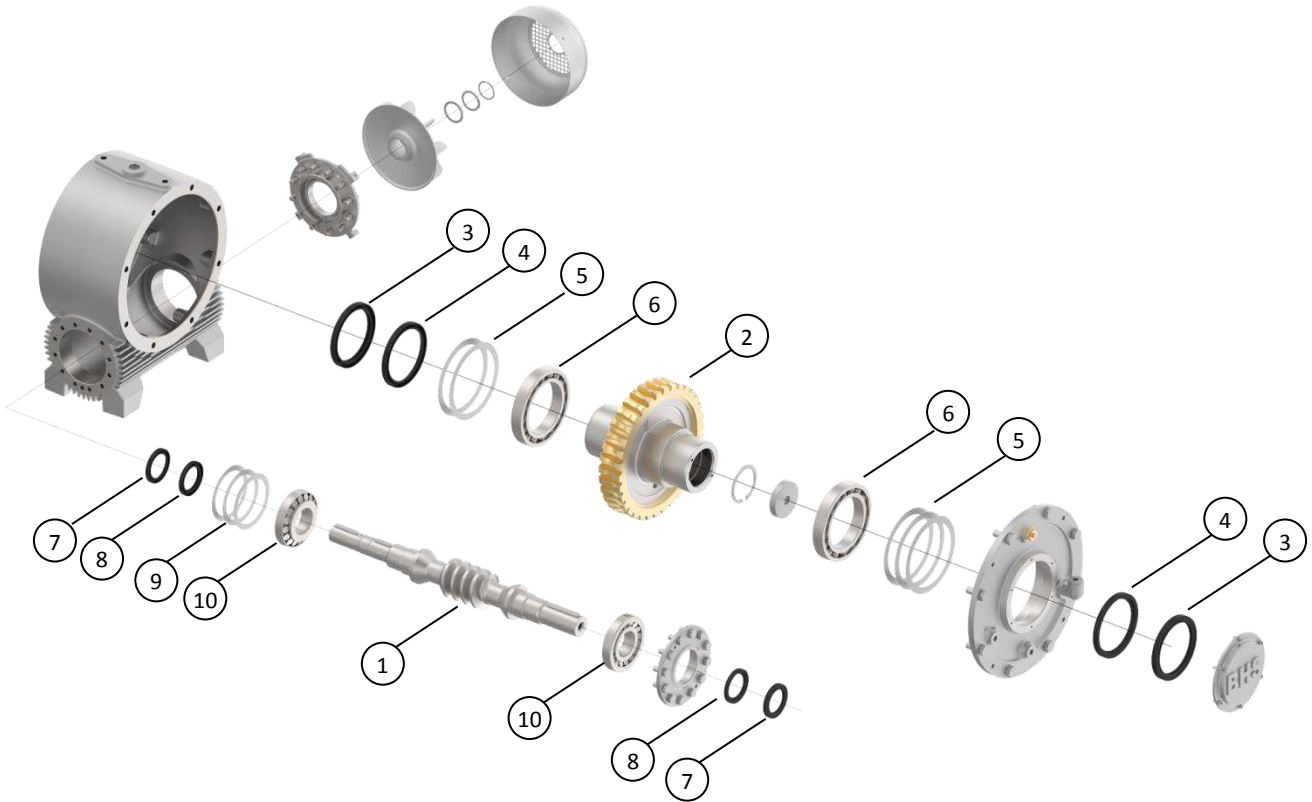

No.	Benennung Description	Bemerkung Remarks
1	Schneckenwelle Worm shaft	
2	Schneckenrad Worm gear	
3	Wellendichtring Shaft seal ring DIN3760-AS120x150x13-NBR-G	
4	Wellendichtring Shaft seal ring DIN3760-A120x150x12-NBR-G	
5	Passscheiben Shim rings DIN988-150x180-St	
6	Rillenkugellager Groove ball bearing DIN625-6024-J	
7	Wellendichtring Shaft seal ring DIN3760-AS55x80x8-NBR	
8	Wellendichtring Shaft seal ring DIN3760-A55x80x8-NBR	
9	Passscheiben Shim rings DIN988-105x130-St	
10	Kegelrollenlager Taper roller bearing DIN720-31312-J	

# Ersatzteilliste

## List of spare parts

Schneckengetriebe / Worm Gearbox

Product Management

BHS Artikelnummer / Item no.	Zeichnung / Drawing
920006431	S200.1-0001-A
920006432	S200.1-0002-A
920007278	S200.1-0004-A
920007279	S200.1-0005-A
920006588	S200.1-0009-A

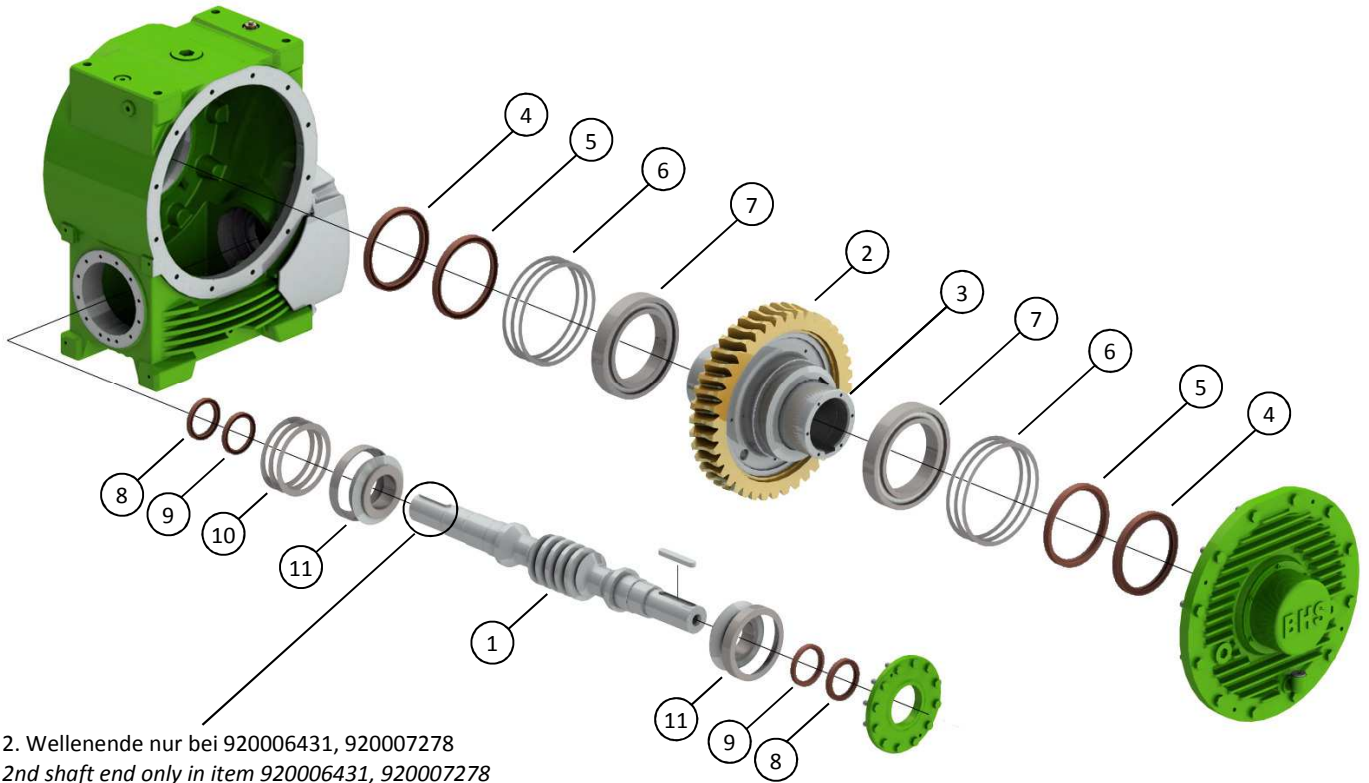

No.	Benennung Description	Bemerkung Remarks
1	Schneckenwelle Worm	
2	Schneckenrad Worm gear	
3	Hohlwelle Hollow shaft	
4	Wellendichtring Shaft seal ring	DIN3760-AS130x160x12-FKM-G
5	Wellendichtring Shaft seal ring	DIN3760-A130x160x12-FKM-G
6	Passscheiben Shim rings	DIN988-170,0x200-St
7	Rillenkugellager Groove ball bearing	DIN625-6026-J
8	Wellendichtring Shaft seal ring	DIN3760-AS60x85x8-FKM-G
9	Wellendichtring Shaft seal ring	DIN3760-A60x85x8-FKM-G
10	Passscheiben Shim rings	DIN988-110,0x140-St
11	Kegelrollenlager Taper roller bearing	DIN720-31313-J



# Ersatzteilliste

## List of spare parts

Schneckengetriebe / Worm Gearbox

Product Management

BHS Artikelnummer / Item no.	Zeichnung / Drawing
920005818	SOG225-0002-A
920005819	SOG225-0001-A
920006474	S225.1-0001-A
920006475	S225.1-0002-A
920007012	S225.1-0003-A
920007013	S225.1-0004-A

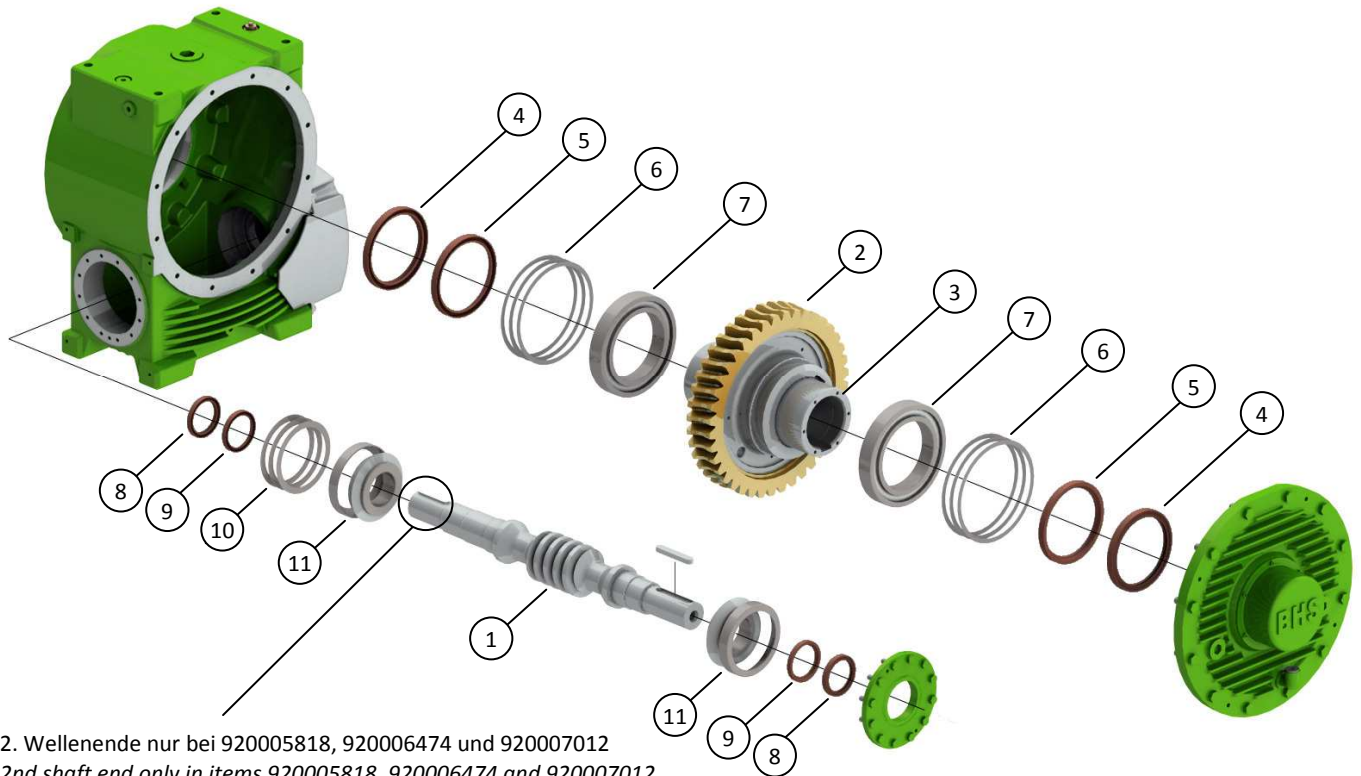

2. Wellenende nur bei 920005818, 920006474 und 920007012  
 2nd shaft end only in items 920005818, 920006474 and 920007012

No.	Benennung Description	Bemerkung Remarks
1	Schneckenwelle Worm shaft	
2	Schneckenrad Worm gear	
3	Hohlwelle Hollow shaft	
4	Wellendichtring Shaft seal ring	DIN3760-AS160x190x15-FKM-G
5	Wellendichtring Shaft seal ring	DIN3760-A160x190x15-FKM-G
6	Passscheiben Shim rings	DIN988-220,0x240-St
7	Rillenkugellager Groove ball bearing	DIN625-6032-J
8	Wellendichtring Shaft seal ring	DIN3760-AS75x95x10-FKM-G
9	Wellendichtring Shaft seal ring	DIN3760-A75x95x10-FKM-G
10	Passscheiben Shim rings	DIN988-140,0x170-St
11	Kegelrollenlager Taper roller bearing	DIN720-31316-J



# Ersatzteilliste

## List of spare parts

Schneckengetriebe / Worm Gearbox

Product Management

BHS Artikelnummer / Item no.	Zeichnung / Drawing
920005160	SOG250-0042-A
920005161	SOG250-0043-A
920005645	SOG250-0045-A
920005644	SOG250-0044-A
920007014	S250.1-0002-A
920007015	S250.1-0003-A

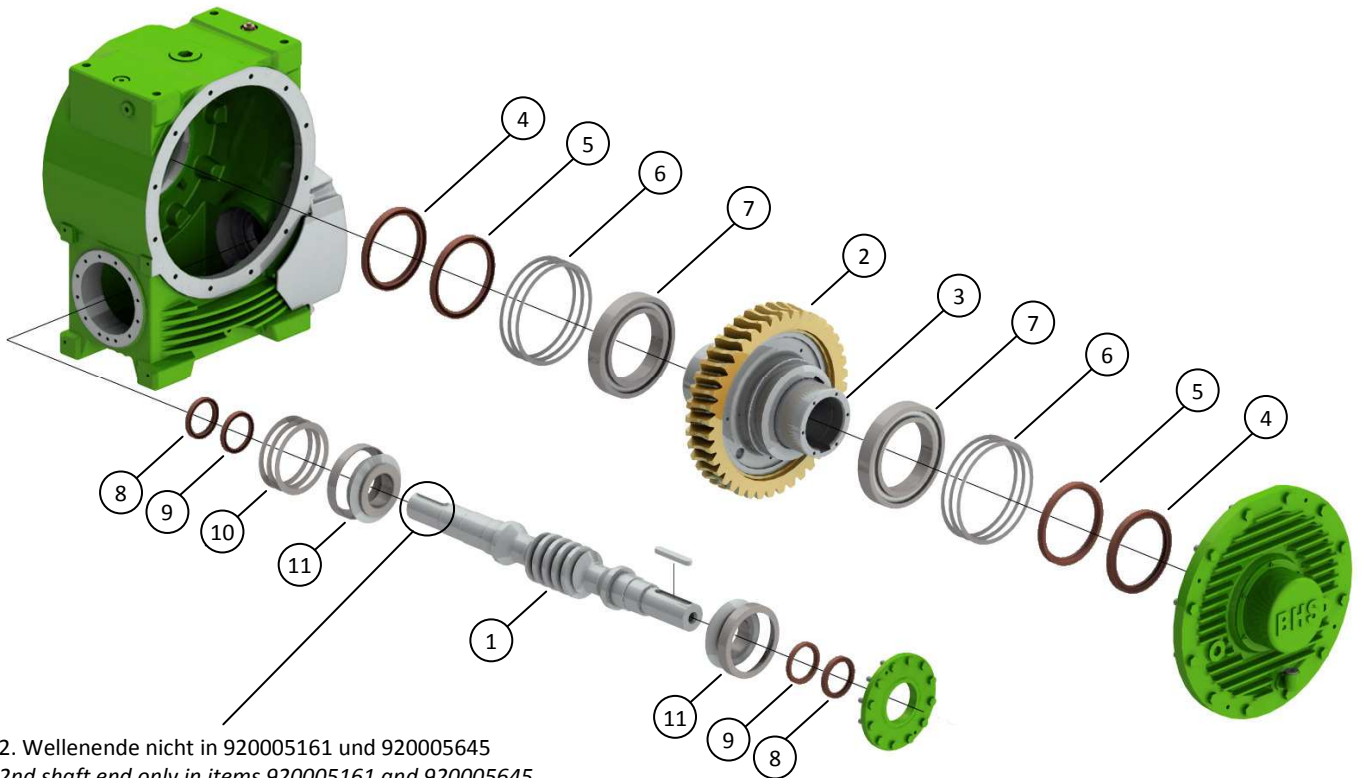

2. Wellenende nicht in 920005161 und 920005645  
2nd shaft end only in items 920005161 and 920005645

No.	Benennung Description	Bemerkung Remarks
1	Schneckenwelle Worm	
2	Schneckenrad Worm gear	
3	Hohlwelle Hollow shaft	
4	Wellendichtring Shaft seal ring	DIN3760-AS160x190x15-FKM-G
5	Wellendichtring Shaft seal ring	DIN3760-A160x190x15-FKM-G
6	Passscheiben Shim rings	DIN988-220,0x240-St
7	Rillenkugellager Groove ball bearing	DIN625-6032-J
8	Wellendichtring Shaft seal ring	DIN3760-AS75x95x10-FKM-G
9	Wellendichtring Shaft seal ring	DIN3760-A75x95x10-FKM-G
10	Passscheiben Shim rings	DIN988-140,0x170-St
11	Kegelrollenlager Taper roller bearing	DIN720-31316-J

Ersatzteilliste  
List of spare parts

Schneckengetriebe / Worm Gearbox

Product Management

BHS Artikelnummer / Item no.	Zeichnung / Drawing
920005331	SOG280-0007-A
920005330	SOG280-0008-A
920006961	S280.1-0001-A
920006960	S280.1-0002-A

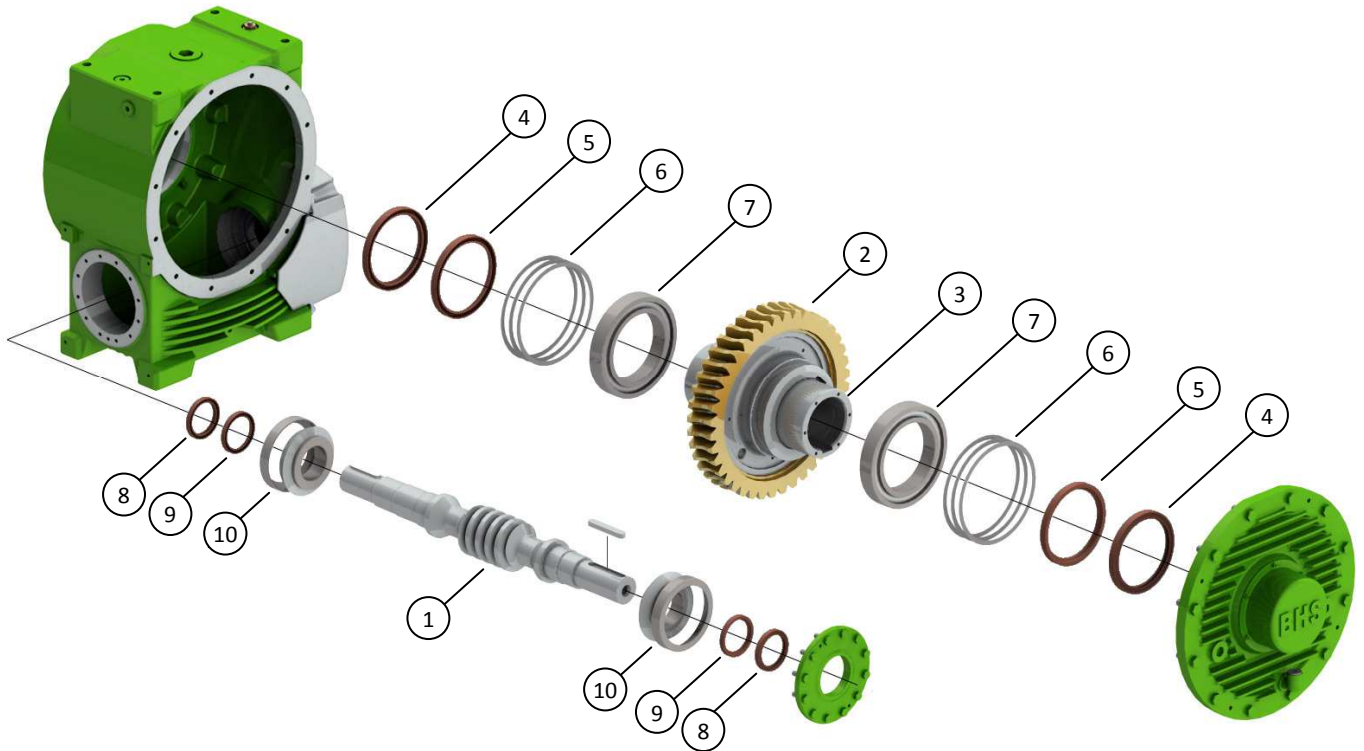

No.	Benennung Description	Bemerkung Remarks
1	Schneckenwelle Worm	
2	Schneckenrad Worm gear	
3	Hohlwelle Hollow shaft	
4	Wellendichtring Shaft seal ring	DIN3760-AS180x210x15-FKM-G
5	Wellendichtring Shaft seal ring	DIN3760-A180x210x15-FKM-G
6	Passscheiben Shim rings	DIN988-250,0x280-St
7	Rillenkugellager Groove ball bearing	DIN625-6036
8	Wellendichtring Shaft seal ring	DIN3760-AS85x120x12-FKM-G
9	Wellendichtring Shaft seal ring	DIN3760-A85x120x12-FKM-G
10	Kegelrollenlager Taper roller bearing	DIN720-31320X-J

Ersatzteilliste  
List of spare parts

Schneckengetriebe / Worm Gearbox

Product Management

BHS Artikelnummer / Item no.	Zeichnung / Drawing
920005329	SOG315-0005-A
920005328	SOG315-0007-A
920005335	SOG315-0006-A
920005334	SOG315-0008-A
920007633	S315.1-0002-A
920007632	S315.1-0003-A
920008843	S315.1-0004-A
920008842	S315.1-0005-A

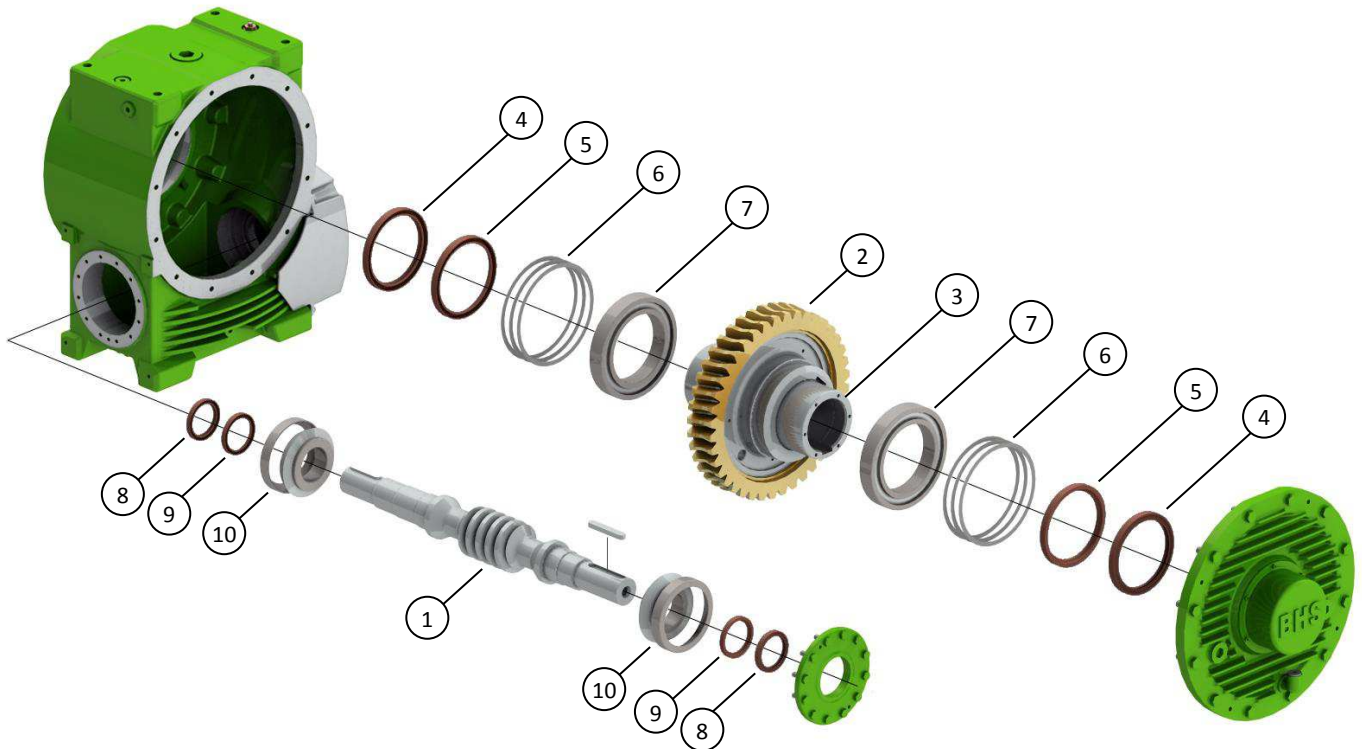

No.	Benennung Description	Bemerkung Remarks
1	Schneckenwelle Worm shaft	
2	Schneckenrad Worm gear	
3	Hohlwelle Hollow shaft	
4	Wellendichtring Shaft seal ring	DIN3760-AS200x230x15-FKM-G
5	Wellendichtring Shaft seal ring	DIN3760-A200x230x15-FKM-G
6	Passscheiben Shim rings	DIN988-280,0x310-St
7	Rillenkugellager Groove ball bearing	DIN625-6040-J
8	Wellendichtring Shaft seal ring	DIN3760-AS95x120x12-FKM-G
9	Wellendichtring Shaft seal ring	DIN3760-A95x120x12-FKM-G
10	Kegelrollenlager Taper roller bearing	DIN720-31320X-J

Ersatzteilliste  
List of spare parts

Schneckengetriebe / Worm Gearbox

Product Management

BHS Artikelnummer / Item no.	Zeichnung / Drawing
(920005329)	SOG315-0001-A
(920005335)	SOG315-0002-A
(920005328)	SOG315-0003-A
(920005334)	SOG315-0004-A

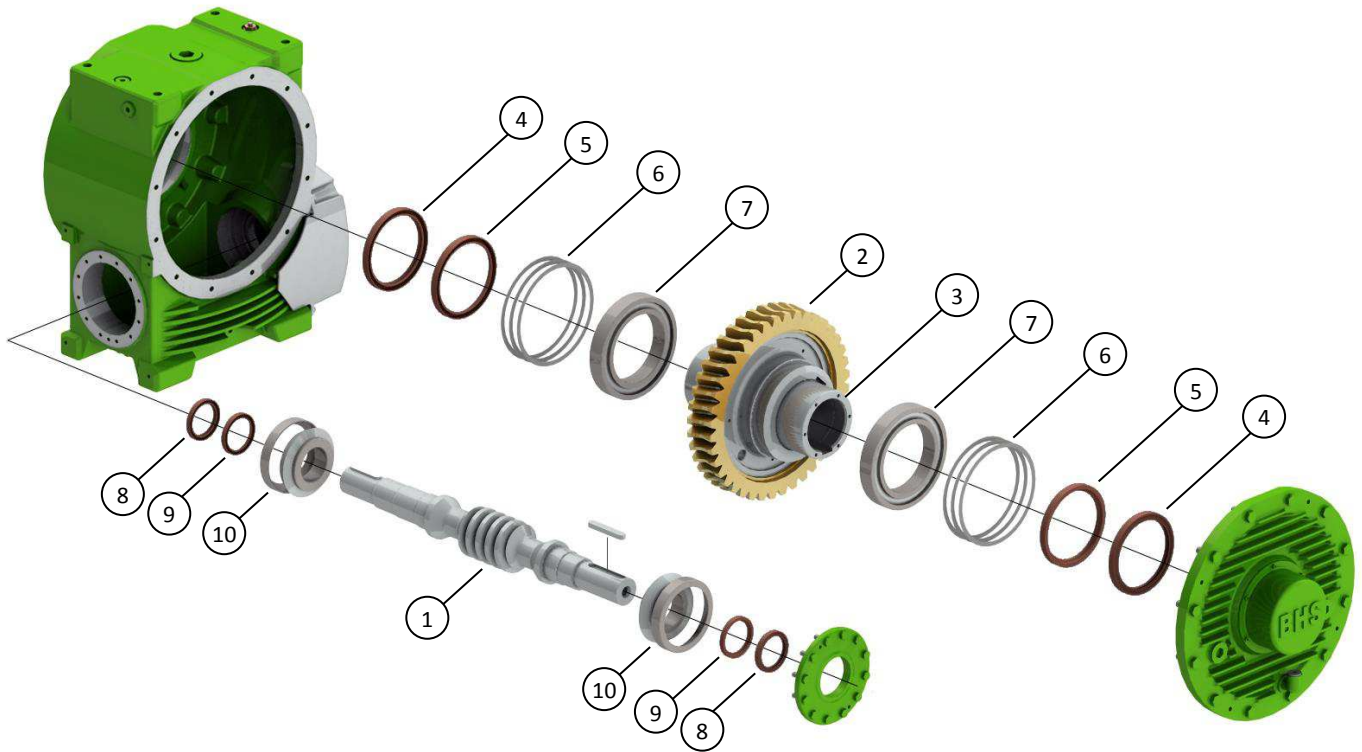

No.	Benennung Description	Bemerkung Remarks
1	Schneckenwelle Worm shaft	
2	Schneckenrad Worm gear	
3	Hohlwelle Hollow shaft	
4	Wellendichtring Shaft seal ring	DIN3760-AS200x230x15-FKM-G
5	Wellendichtring Shaft seal ring	DIN3760-A200x230x15-FKM-G
6	Passscheiben Shim rings	DIN988-280,0x310-St
7	Rillenkugellager Groove ball bearing	DIN625-6040-J
8	Wellendichtring Shaft seal ring	DIN3760-AS95x125x12-FKM-G
9	Wellendichtring Shaft seal ring	DIN3760-A95x125x12-FKM-G
10	Kegelrollenlager Taper roller bearing	DIN720-31320X-J

Ersatzteilliste  
List of spare parts

Schneckengetriebe / Worm Gearbox

Product Management

BHS Artikelnummer / Item no.	Zeichnung / Drawing	Bemerkung / Remarks
920006870	S400.1-0001-A	
920006871	S400.1-0002-A	
920006868	S400.1-0003-A	
920006869	S400.1-0004-A	

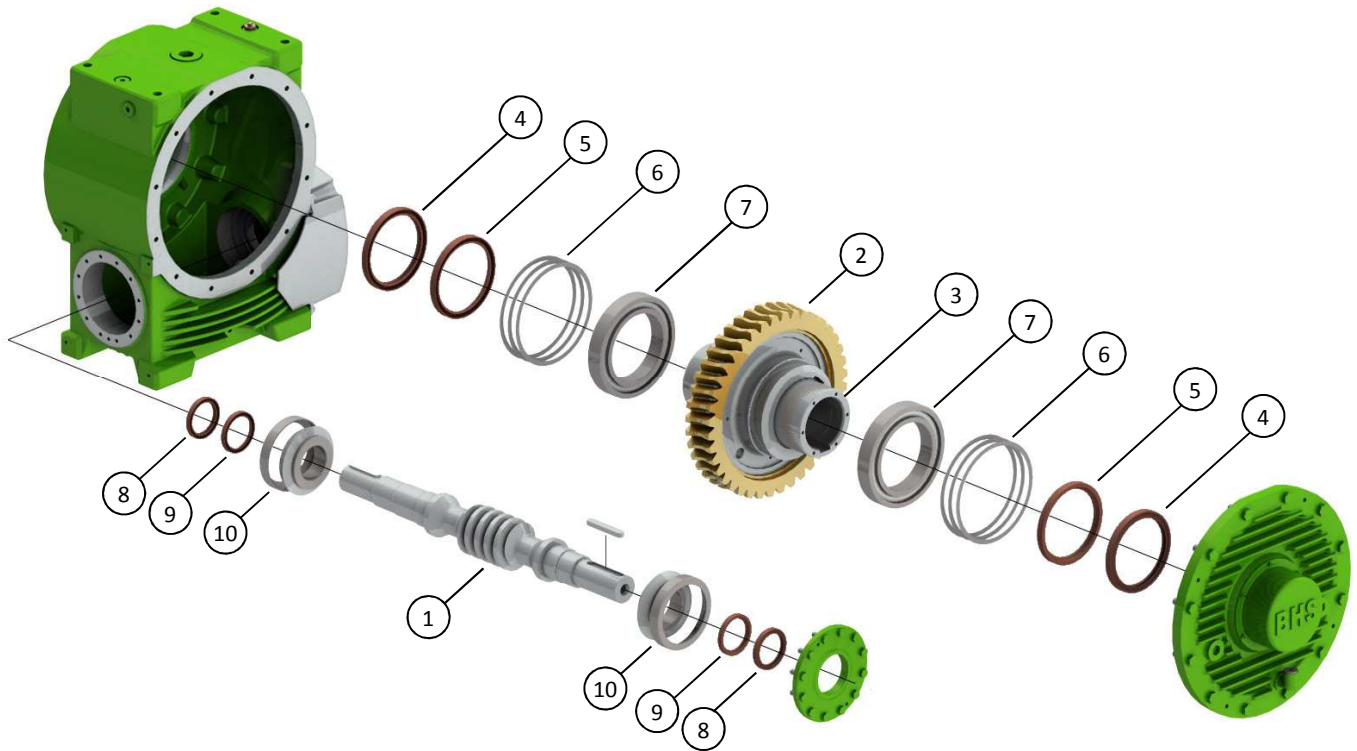

No.	Benennung Description	Bemerkung Remarks
1	Schneckenwelle Worm	
2	Schneckenrad Worm gear	
3	Hohlwelle Hollow shaft	
4	Wellendichtring Shaft seal ring	DIN3760-AS260x300x20-FKM-G
5	Wellendichtring Shaft seal ring	DIN3760-A260x300x20-FKM-G
6	Passscheiben Shim rings	DIN988-360,0x400-St
7	Rillenkugellager Groove ball bearing	DIN625-6052-M
8	Wellendichtring Shaft seal ring	DIN3760-AS105x140x12-FKM-G
9	Wellendichtring Shaft seal ring	DIN3760-A105x140x12-FKM-G
10	Kegelrollenlager Taper roller bearing	DIN720-31322X-J



# Ersatzteilliste

## List of spare parts

Schneckengetriebe / Worm Gearbox

Product Management

BHS Artikelnummer / Item no.	Zeichnung / Drawing	Bemerkung / Remarks
920006962	S450.1-0001-A	
920006963	S450.1-0002-A	

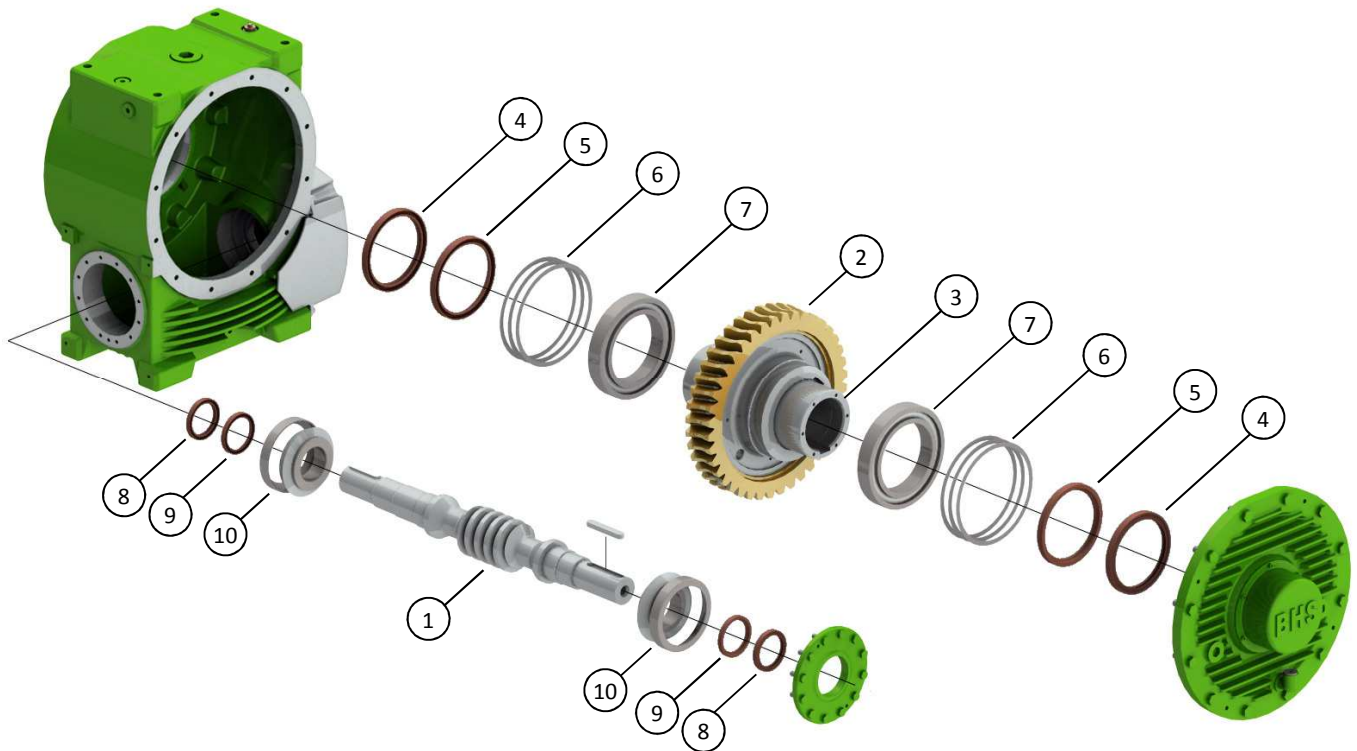

No.	Benennung Description	Bemerkung Remarks
1	Schneckenwelle Worm	
2	Schneckenrad Worm gear	
3	Hohlwelle Hollow shaft	
4	Wellendichtring Shaft seal ring	DIN3760-AS280x320x20-FKM-G
5	Wellendichtring Shaft seal ring	DIN3760-A280x320x20-FKM-G
6	Passscheiben Shim rings	DIN988-380,0x420-St
7	Rillenkugellager Groove ball bearing	DIN625-6065-M
8	Wellendichtring Shaft seal ring	DIN3760-AS115x140x12-FKM-G
9	Wellendichtring Shaft seal ring	DIN3760-A115x140x12-FKM-G
10	Kegelrollenlager Taper roller bearing	DIN720-31324X-J

# Low voltage motors Manual

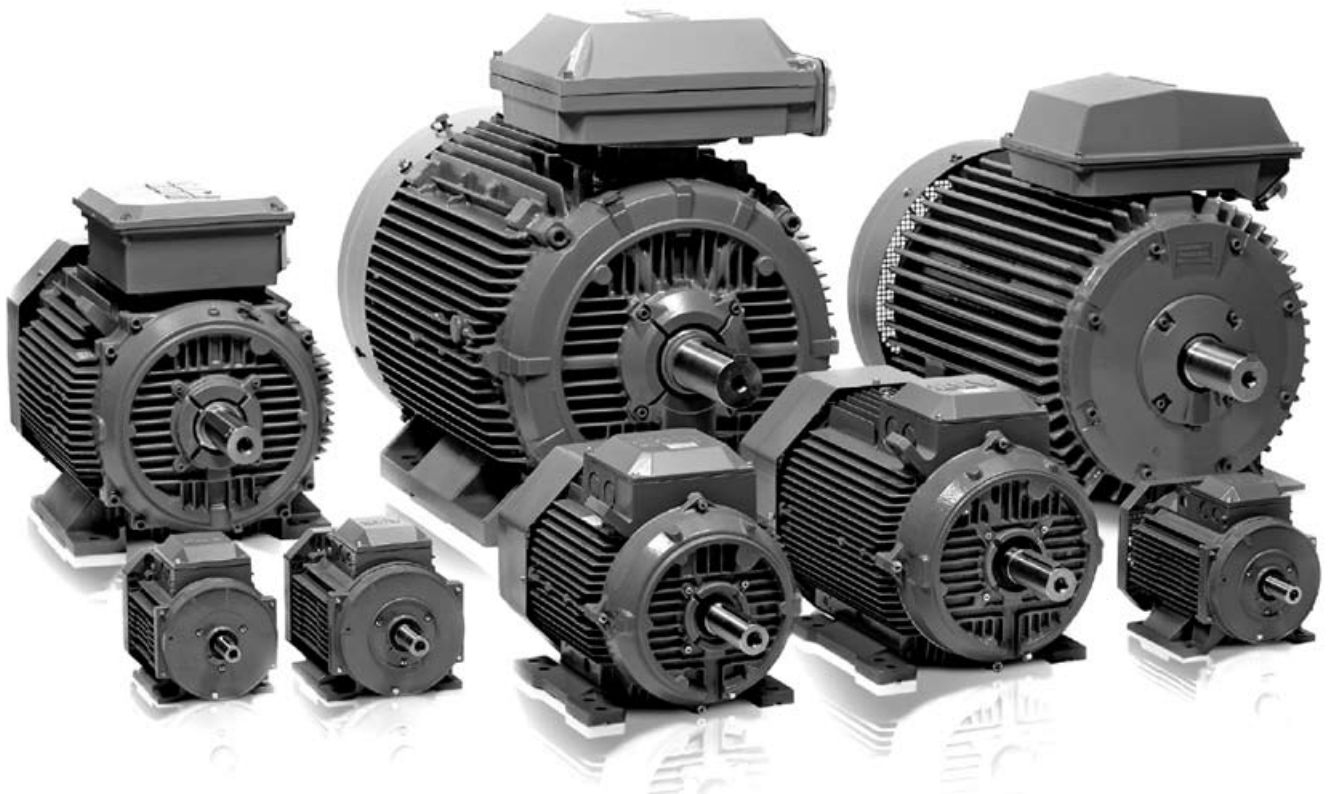

Installation, operation, maintenance and safety manual .....	EN 3
Montage-, Betriebs-, Wartungs- und Sicherheitsanleitung .....	DE 21
Manuel d'installation, d'exploitation, de maintenance et de sécurité .....	FR 39
Manual de instalación, funcionamiento, mantenimiento y seguridad .....	ES 59
Manuale d'installazione, funzionamento e manutenzione .....	IT 79
Manual de instalação, operação, manutenção e segurança .....	PT 99
Installations-, drifts-, underhålls- och säkerhetsmanual .....	SV 119
Asennus-, käyttö-, kunnossapito- ja turvallisuusohje .....	FI 137

More languages – see web site [www.abb.com/motors&generators](http://www.abb.com/motors&generators) > Motors > Document library



## EC Declaration of Conformity

**The Manufacturer:**                    *(Name and address of the manufacturer)*

hereby declares that

**The Products:**                    *(Product identification)*

are in conformity with the corresponding essential requirements of following EC directive:

**Directive 2006/95/EC (of 12 December 2006).**

The motors are in compliance with the following harmonized standard:

EN 60 034-1(2004)

which thus comply with Principal Elements of the Safety Objectives for Electrical Equipement stated in Annex I of said directive.

**Note:** When installing motors for converter supply applications, additional requirements must be respected regarding the motor as well as the installation, as described in installation manual delivered with converters.

Year of CE marking :

Signed by

-----

Title

-----

Date

-----



# Low Voltage Motors

## Installation, operation, maintenance and safety manual

<b>List of Contents</b>	<b>Page</b>
<b>1. Introduction .....</b>	<b>5</b>
1.1 Declaration of Conformity .....	5
1.2 Validity .....	5
<b>2. Handling .....</b>	<b>6</b>
2.1 Reception check .....	6
2.2 Transportation and storage .....	6
2.3 Lifting .....	6
2.4 Machine weight .....	6
<b>3. Installation and commissioning .....</b>	<b>7</b>
3.1 General .....	7
3.2 Insulation resistance check .....	7
3.3 Foundation .....	7
3.4 Balancing and fitting coupling halves and pulleys .....	8
3.5 Mounting and alignment of the motor .....	8
3.6 Slide rails and belt drives .....	8
3.7 Machines with drain plugs for condensation .....	8
3.8 Cabling and electrical connections .....	8
3.8.1 Connections for different starting methods .....	9
3.8.2 Connections of auxiliaries .....	9
3.9 Terminals and direction of rotation .....	9
<b>4. Operation .....</b>	<b>10</b>
4.1 Use .....	10
4.2 Cooling .....	10
4.3 Safety considerations .....	10

<b>5. Low voltage motors in variable speed operation .....</b>	<b>11</b>
5.1 Introduction .....	11
5.2 Winding insulation .....	11
5.2.1 Phase to phase voltages .....	11
5.2.1 Phase to ground voltages .....	11
5.2.3 Selection of winding insulation for ACS550- and ACS800-converters .....	11
5.2.4 Selection of winding insulation with all other converters .....	11
5.3 Thermal protection of windings .....	11
5.4 Bearing currents .....	12
5.4.1 Elimination of bearing currents with ABB ACS550 and ACS800 converters .....	12
5.4.2 Elimination of bearing currents with all other converters .....	12
5.5 Cabling, grounding and EMC .....	12
5.6 Operating speed .....	12
5.7 Dimensioning the motor for variable speed application .....	12
5.7.1 General .....	12
5.7.2 Dimensioning with ABB ACS800 converters with DTC control .....	12
5.7.3 Dimensioning with ABB ACS550 converters .....	13
5.7.4 Dimensioning with other voltage source PWM-type converters .....	13
5.7.5 Short time overloads .....	13
5.8 Rating plates .....	13
5.9 Commissioning the variable speed application .....	13
<b>6. Maintenance .....</b>	<b>14</b>
6.1 General inspection .....	14
6.1.1 Standby motors .....	14
6.2 Lubrication .....	14
6.2.1 Machines with permanently greased bearings .....	14
6.2.2 Motors with regreasable bearings .....	15
6.2.3 Lubrication intervals and amounts .....	15
6.2.4 Lubricants .....	17
<b>7. After Sales Support .....</b>	<b>18</b>
7.1 Spare parts .....	18
7.2 Rewinding .....	18
7.3 Bearings .....	18
<b>8. Environmental requirements .....</b>	<b>18</b>
8.1 Noise levels .....	18
<b>9. Troubleshooting .....</b>	<b>19</b>

# 1. Introduction

## NOTE!

These instructions must be followed to ensure safe and proper installation, operation and maintenance of the machine. They should be brought to the attention of anyone who installs, operates or maintains the machine or associated equipment. The machine is intended for installation and use by qualified personnel, familiar with health and safety requirements and national legislation. Ignoring these instructions may invalidate all applicable warranties.

## 1.1 Declaration of Conformity

Declarations of Conformity with respect to the Low voltage Directive 73/23/EEC amended by Directive 93/68 EEC are issued separately with individual machines.

The Declaration of Conformity also satisfies the requirements of a Declaration of Incorporation with respect to the Machinery Directive 98/37/EEC, Art 4.2 Annex II, sub B

## 1.2 Validity

The instructions are valid for the following ABB electrical machine types, in both motor and generator operation.

series MT\*, MXMA,  
series M2A\*/M3A\*, M2B\*/M3B\*, M4B\*, M2C\*/M3C\*,  
M2F\*/M3F\*, M2L\*/M3L\*, M2M\*/M3M\*, M2Q\*,  
M2R\*/M3R\*, M2V\*/M3V\*  
in frame sizes 56 - 450.

There is a separate manual for e.g. Ex motors 'Low voltage motors for hazardous areas: Installation, operation and maintenance Manual' (Low Voltage Motors/Manual for Ex-motors).

Additional information is required for some machine types due to special application and/or design considerations.

Additional information is available for the following motors:

- roller table motors
- water cooled motors
- open drip proof motors
- smoke venting motors
- brake motors
- motors for high ambient temperatures

## 2. Handling

### 2.1 Reception check

Immediately upon receipt check the motor for external damage (e.g. shaft-ends and flanges and painted surfaces) and if found, inform the forwarding agent without delay.

Check all rating plate data, especially voltage and winding connection (star or delta). The type of bearing is specified on the rating plate of all motors except the smallest frame sizes.

### 2.2 Transportation and storage

The motor should always be stored indoors (above  $-20^{\circ}\text{C}$ ), in dry, vibration free and dust free conditions. During transportation, shocks, falls and humidity should be avoided. In other conditions, please contact ABB.

Unprotected machined surfaces (shaft-ends and flanges) should be treated against corrosion.

It is recommended that shafts are rotated periodically by hand to prevent grease migration.

Anti-condensation heaters, if fitted, are recommended to be used to avoid water condensing in the motor.

The motor must not be subject to any external vibrations at standstill so as to avoid causing damage to the bearings.

Motors fitted with cylindrical-roller and/or angular contact bearings must be fitted with locking devices during transport.

### 2.3 Lifting

All ABB motors above 25 kg are equipped with lifting lugs or eyebolts.

Only the main lifting lugs or eyebolts of the motor should be used for lifting the motor. They must not be used to lift the motor when it is attached to other equipment.

Lifting lugs for auxiliaries (e.g. brakes, separate cooling fans) or terminal boxes must not be used for lifting the motor.

Motors with the same frame may have a different center of gravity because of different output, mounting arrangements and auxiliary equipment.

Damaged lifting lugs must not be used. Check that eyebolts or integrated lifting lugs are undamaged before lifting.

Lifting eyebolts must be tightened before lifting. If needed, the position of the eyebolt can be adjusted using suitable washers as spacers.

Ensure that proper lifting equipment is used and that the sizes of the hooks are suitable for the lifting lugs.

Care must be taken not to damage auxiliary equipment and cables connected to the motor.

### 2.4 Machine weight

The total machine weight can vary within the same frame size (center height) depending on different output, mounting arrangement and auxiliaries.

The following table shows estimated maximum weights for machines in their basic versions as a function of frame material.

The actual weight of all ABB's motors, except the smallest frame sizes (56 and 63) is shown on the rating plate.

Frame size	Aluminum Weight kg	Cast iron Weight kg	Steel Weight kg	Add. for brake
56	4.5	-		-
63	6	-		-
71	8	13		5
80	12	20		8
90	17	30		10
100	25	40		16
112	36	50		20
132	63	90		30
160	95	130		30
180	135	190		45
200	200	275		55
225	265	360		75
250	305	405		75
280	390	800	600	-
315	-	1700	1000	-
355	-	2700	2200	-
400	-	3500	3000	-
450	-	4500	-	-

# 3. Installation and commissioning

## WARNING

Disconnect and lock out before working on the motor or the driven equipment.

## 3.1 General

All rating plate values must be carefully checked to ensure that the motor protection and connection will be properly done.

## WARNING

In case of motors mounted with the shaft upwards and water or liquids are expected to go down along the shaft, the user must take in account to mount some means capable of preventing it.

Remove transport locking if employed. Turn shaft by hand to check free rotation if possible.

### Motors equipped with roller bearings:

Running the motor with no radial force applied to the shaft may damage the roller bearing.

### Motors equipped with angular contact bearing:

Running the motor with no axial force applied in the right direction in relation to the shaft may damage the angular contact bearing.

## WARNING

For machines with angular contact bearings the axial force must not by any means change direction.

The type of bearing is specified on the rating plate.

### Motors equipped with regreasing nipples:

When starting the motor for the first time, or after long storage, apply the specified quantity of grease.

For details, see section “6.2.2 Motors with regreasable bearings”.

## 3.2 Insulation resistance check

Measure insulation resistance before commissioning and when winding dampness is suspected.

## WARNING

Disconnect and lock out before working on the motor or the driven equipment.

Insulation resistance, corrected to 25°C, must exceed the reference value, i.e. 100 MΩ (measured with 500 or 1000 V DC). The insulation resistance value is halved for each 20°C rise in ambient temperature.

## WARNING

The motor frame must be grounded and the windings should be discharged against the frame immediately after each measurement to avoid risk of electrical shock.

If the reference resistance value is not attained, the winding is too damp and must be oven dried. The oven temperature should be 90°C for 12-16 hours followed by 105°C for 6-8 hours.

Drain hole plugs, if fitted, must be removed and closing valves, if fitted, must be opened during heating. After heating, make sure the plugs are refitted. Even if the drain plugs are fitted, it is recommended to disassemble the end shields and terminal box covers for the drying process.

Windings drenched in seawater normally need to be rewound.

## 3.3 Foundation

The end user has full responsibility for preparation of the foundation.

Metal foundations should be painted to avoid corrosion.

Foundations must be even, see figure below, and sufficiently rigid to withstand possible short circuit forces. They must be designed and dimensioned to avoid the transfer of vibration to the motor and vibration caused by resonance.

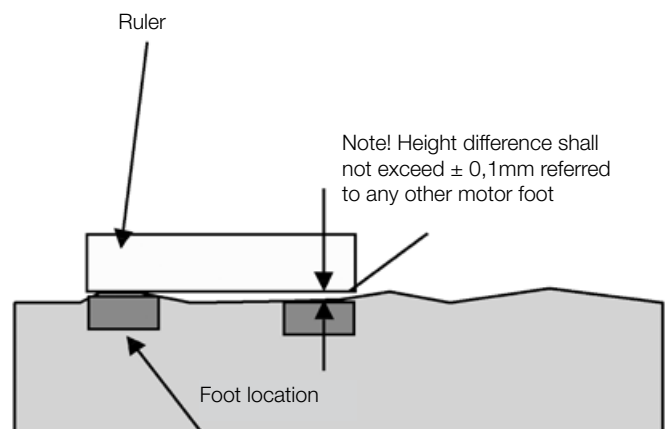

### 3.4 Balancing and fitting coupling halves and pulleys

As standard, balancing of the motor has been carried out using half key

When balancing with full key, the shaft is marked with YELLOW tape, with the text “Balanced with full key”.

In case of balancing without key, the shaft is marked with BLUE tape, with the text “Balanced without key”.

Coupling halves or pulleys must be balanced after machining the keyways. Balancing must be done in accordance with the balancing method specified for the motor.

Coupling halves and pulleys must be fitted on the shaft by using suitable equipment and tools which do not damage the bearings and seals.

Never fit a coupling half or pulley by hammering or by removing it using a lever pressed against the body of the motor.

### 3.5 Mounting and alignment of the motor

Ensure that there is enough space for free airflow around the motor. Minimum requirements for free space behind the motor fan cover can be found from the product catalog or from the dimension drawings available from the web: see [www.abb.com/motors&generators](http://www.abb.com/motors&generators).

Correct alignment is essential to avoid bearing, vibration and possible shaft failures.

Mount the motor on the foundation using the appropriate bolts or studs and place shim plates between the foundation and the feet.

Align the motor using appropriate methods.

If applicable, drill locating holes and fix the locating pins into position.

Mounting accuracy of coupling half: check that clearance  $b$  is less than 0.05 mm and that the difference  $a_1$  to  $a_2$  is also less than 0.05 mm. See Figure 3.

Re-check the alignment after final tightening of the bolts or studs.

Do not exceed permissible loading values for bearings as stated in the product catalogues.

### 3.6 Slide rails and belt drives

Fasten the motor to the slide rails as shown in Figure 2.

Place the slide rails horizontally on the same level.

Check that the motor shaft is parallel with the drive shaft.

Belts must be tensioned according to the instructions of the supplier of the driven equipment. However, do not exceed the maximum belt forces (i.e. radial bearing loading) stated in the relevant product catalogues.

#### WARNING

Excessive belt tension will damage bearings and can cause shaft damage.

### 3.7 Machines with drain plugs for condensation

Check that drain holes and plugs face downwards.

Machines with sealable plastic drain plugs are delivered in open position. In very dusty environments, all drain holes should be closed.

### 3.8 Cabling and electrical connections

The terminal box on standard single speed motors normally contains six winding terminals and at least one earth terminal.

In addition to the main winding and earthing terminals, the terminal box can also contain connections for thermistors, heating elements or other auxiliary devices.

Suitable cable lugs must be used for the connection of all main cables. Cables for auxiliaries can be connected into their terminal blocks as such.

Machines are intended for fixed installation only. If not otherwise specified, cable entry threads are metric. The IP-class of the cable gland must be at least the same as those of the terminal boxes.

Unused cable entries must be closed with blanking elements according to the IP class of the terminal box.

The degree of protection and diameter are specified in the documents relating to the cable gland.

**WARNING**

Use appropriate cable glands and seals in the cable entries according to the type and diameter of the cable.

Additional information on cables and glands suitable for variable speed applications can be found from chapter 5.5.

Earthing must be carried out according to local regulations before the machine is connected to the supply voltage.

Ensure that the motor protection corresponds to the environment and weather conditions; for example, make sure that water cannot enter the motor or the terminal boxes.

The seals of terminal boxes must be placed correctly in the slots provided, to ensure the correct IP class.

### **3.8.1 Connections for different starting methods**

The terminal box on standard single speed motors normally contains six winding terminals and at least one earth terminal. This enables the use of DOL- or Y/D –starting. See Figure 1.

For two-speed and special motors, the supply connection must follow the instructions inside the terminal box or in the motor manual.

The voltage and connection are stamped on the rating plate.

#### **Direct-on-line starting (DOL):**

Y or D winding connections may be used.

For example, 690 VY, 400 VD indicates Y-connection for 690 V and D-connection for 400 V.

#### **Star/Delta starting (Y/D):**

The supply voltage must be equal to the rated voltage of the motor when using a D-connection.

Remove all connection links from the terminal block.

#### **Other starting methods and severe starting conditions:**

In case other starting methods are used, such as a soft starter, or if starting conditions are particularly difficult, please consult ABB first.

### **3.8.2 Connections of auxiliaries**

If a motor is equipped with thermistors or other RTDs (Pt100, thermal relays, etc.) and auxiliary devices, it is recommended they be used and connected by appropriate means. Connection diagrams for auxiliary elements and connection parts can be found inside the terminal box.

Maximum measuring voltage for the thermistors is 2.5 V. Maximum measuring current for Pt100 is 5 mA. Using a higher measuring voltage or current may cause errors in readings or damage the system.

The insulations of the winding thermal sensors is of basic type. While connecting the sensors to control systems etc, ensure adequate insulation or isolation, see IEC 60664.

**NOTE!**

Ensure the insulation level or isolation of thermistor circuit, see IEC 60664.

## **3.9 Terminals and direction of rotation**

The shaft rotates clockwise when viewing the shaft face at the motor drive end, and the line phase sequence - L1, L2, L3 - is connected to the terminals as shown in Figure 1.

To alter the direction of rotation, interchange any two connections on the supply cables.

If the motor has a unidirectional fan, ensure that it rotates in the same direction as the arrow marked on the motor.

## 4. Operation

### 4.1 Use

The motors are designed for the following conditions unless otherwise stated on the rating plate.

- Normal ambient temperature limits are -20°C to +40°C.
- Maximum altitude 1000 m above sea level.
- Tolerance for supply voltage is  $\pm 5\%$  and for frequency  $\pm 2\%$  according to EN / IEC 60034-1 (2004).

The motor can only be used in applications it is intended for. The rated nominal values and operational conditions are shown on the motor rating plates. In addition, all requirements of this manual and other related instructions and standards must be followed.

If these limits are exceeded, motor data and construction data must be checked. Please contact ABB for further information.

#### **WARNING**

Ignoring any of given instructions or maintenance of the apparatus may jeopardize the safety and thus prevents the use of the machine.

### 4.2 Cooling

Check that the motor has sufficient airflow. Ensure that no nearby objects or direct sunshine radiate additional heat to the motor.

For flange mounted motors (e.g. B5, B35, V1), make sure that the construction allows sufficient air flow on the outer surface of the flange.

### 4.3 Safety considerations

The machine is intended for installation and use by qualified personnel, familiar with health and safety requirements and national legislation.

Safety equipment necessary for the prevention of accidents at the installation and operating site must be provided in accordance with local regulations.

#### **WARNING**

Do not carry out work on motor, connection cables or accessories such as frequency converters, starters, brakes, thermistor cables or heating elements when voltage is applied.

#### **Points to observe**

1. Do not step on the motor.
2. The temperature of the outer casing of the motor may be too hot to touch during normal operation and especially after shut-down.
3. Some special motor applications require special instructions (e.g. using frequency converter supplies).
4. Be aware of rotating parts of the motor.
5. Do not open terminal boxes while energized.



# 5. Low voltage motors in variable speed operation

## 5.1 Introduction

This part of the manual provides additional instructions for motors used in frequency converter supply. Instructions provided in this and respective manuals of selected frequency converter must be followed to ensure safety and availability of the motor.

Additional information may be required by ABB to decide on the suitability for some machine types used in special applications or with special design modifications.

## 5.2 Winding insulation

Variable speed drives cause higher voltage stresses than the sinusoidal supply on the winding of the motor and therefore the winding insulation of the motor as well as the filter at the converter output must be dimensioned according following instructions.

### 5.2.1 Phase to phase voltages

The maximum allowed phase to phase voltage peaks at the motor terminal as a function of the rise time of the pulse can be seen in Figure 1.

The highest curve “ABB Special Insulation” applies to motors with a special winding insulation for frequency converter supply, variant code 405.

The “ABB Standard Insulation” applies to all other motors covered by this manual.

### 5.2.2 Phase to ground voltages

The allowed phase to ground voltage peaks at motor terminals are:

Standard Insulation 1300 V peak

Special Insulation 1800 V peak

### 5.2.3 Selection of winding insulation for ACS800 and ACS550 converters

In the case of ABB ACS800-series and ACS550-series single drives with a diode supply unit (uncontrolled DC voltage), the selection of winding insulation and filters can be made according to table below:

Nominal supply voltage $U_N$ of the converter	Winding insulation and filters required
$U_N \leq 500$ V	ABB Standard insulation
$U_N \leq 600$ V	ABB Standard insulation + dU/dt filters OR ABB Special insulation (variant code 405)
$U_N \leq 690$ V	ABB Special insulation (variant code 405) AND dU/dt-filters at converter output
$U_N \leq 690$ V AND cable length > 150 m	ABB Special insulation (variant code 405)

For more information on resistor braking and converters with controlled supply units, please contact ABB.

### 5.2.4 Selection of winding insulation with all other converters

The voltage stresses must be limited below accepted limits. Please contact the system supplier to ensure the safety of the application. The influence of possible filters must be taken into account while dimensioning the motor.

## 5.3 Thermal protection

Most of the motors covered by this manual are equipped with PTC thermistors in the stator windings. It is recommended to connect those to the frequency converter by appropriate means. See also chapter 3.8.2.

## 5.4 Bearing currents

Insulated bearings or bearing constructions, common mode filters and suitable cabling and grounding methods must be used according to the following instructions:

### 5.4.1 Elimination of bearing currents with ABB ACS800 and ACS550 converters

In the case of the ABB ACS800 and ACS550-series frequency converter with a diode supply unit, the following methods must be used to avoid harmful bearing currents in the motors:

Nominal Power (Pn) and / or Frame size (IEC)	Preventive measures
Pn < 100 kW	No actions needed
Pn ≥ 100 kW OR IEC 315 ≤ Frame size ≤ IEC 355	Insulated non-drive end bearing
Pn ≥ 350 kW OR IEC 400 ≤ Frame size ≤ IEC 450	Insulated non-drive end bearing AND Common mode filter at the converter

Insulated bearings which have aluminum oxide coated inner and/or outer bores or ceramic rolling elements, are recommended. Aluminum oxide coatings shall also be treated with a sealant to prevent dirt and humidity penetrating into the porous coating. For the exact type of bearing insulation, see the motor's rating plate. Changing the bearing type or insulation method without ABB's permission is prohibited.

### 5.4.2 Elimination of bearing currents with all other converters

The user is responsible for protecting the motor and driven equipment from harmful bearing currents. Instructions described in Chapter 5.4.1 can be used as guideline, but their effectiveness cannot be guaranteed in all cases.

## 5.5 Cabling, grounding and EMC

To provide proper grounding and to ensure compliance with any applicable EMC requirements, motors above 30 kW shall be cabled by shielded symmetrical cables and EMC glands, i.e. cable glands providing 360° bonding. Also for smaller motors symmetrical and shielded cables are highly recommended. Make the 360° grounding arrangement at all the cable entries as described in the instructions for the glands. Twist the cable shields into bundles and connect to the nearest ground terminal/bus bar inside the terminal box, converter cabinet, etc.

#### NOTE!

Proper cable glands providing 360° bonding must be used at all termination points, e.g. at motor, converter, possible safety switch, etc.

For motors of frame size IEC 280 and upward, additional potential equalization between the motor frame and the driven equipment is needed, unless both are mounted on a common steel base. In this case, the high frequency conductivity of the connection provided by the steel base should be checked by, for example, measuring the potential difference between the components.

More information about grounding and cabling of variable speed drives can be found in the manual "Grounding and cabling of the drive system" (Code: 3AFY 61201998).

## 5.6 Operating speed

For speeds higher than the nominal speed stated on the motor's rating plate or in the respective product catalogue, ensure that either the highest permissible rotational speed of the motor or the critical speed of the whole application is not exceeded.

## 5.7 Dimensioning the motor for variable speed application

### 5.7.1 General

In case of ABB's frequency converters, the motors can be dimensioned by using ABB's DriveSize dimensioning program. The tool is downloadable from the ABB website ([www.abb.com/motors&generators](http://www.abb.com/motors&generators)).

For application supplied by other converters, the motors must be dimensioned manually. For more information, please contact ABB.

The loadability curves (or load capacity curves) are based on nominal supply voltage. Operation in under or over voltage conditions may influence on the performance of the application.

### 5.7.2 Dimensioning with ABB ACS800 converters with DTC control

The loadability curves presented in Figures 4a - 4d are valid for ABB ACS800 converters with uncontrolled DC-voltage and DTC-control. The figures show the approximate maximum continuous output torque of the motors as a function of supply frequency. The output torque is given as a percentage of the nominal torque of the motor. The values are indicative and exact values are available on request.

#### NOTE!

The maximum speed of the motor must not be exceeded!

### 5.7.3 Dimensioning with ABB ACS550 converters

The loadability curves presented in Figures 5a - 5d are valid for ABB ACS550 series converters. The figures show the approximate maximum continuous output torque of the motors as a function of supply frequency. The output torque is given as a percentage of the nominal torque of the motor. The values are indicative and exact values are available on request.

**NOTE!**

The maximum speed of the motor must not be exceeded!

### 5.7.4 Dimensioning with other voltage source PWM-type converters

For other converters, which have uncontrolled DC voltage and minimum switching frequency of 3 kHz, the dimensioning instructions of ACS550 can be used as guidelines, but it shall be noted, that the actual thermal loadability can also be lower. Please contact the manufacturer of the converter or the system supplier.

**NOTE!**

The actual thermal loadability of a motor may be lower than shown by guideline curves.

### 5.7.5 Short time overloads

ABB motors can usually be temporarily overloaded as well as used in intermittent duties. The most convenient method to dimension such applications is to use the DriveSize tool.

## 5.8 Rating plates

The usage of ABB's motors in variable speed applications do not usually require additional rating plates and the parameters required for commissioning the converter can be found from the main rating plate. However, in some special applications the motors can be equipped with additional rating plates for variable speed applications and those include following information:

- speed range
- power range
- voltage and current range
- type of torque (constant or quadratic)
- converter type and required minimum switching frequency

## 5.9 Commissioning the variable speed application

The commissioning of the variable speed application must be done according to the instructions of the frequency converter and local laws and regulations. The requirements and limitations set by the application must also be taken into account.

All parameters needed for setting the converter must be taken from the motor rating plates. The most often needed parameters are:

- Motor nominal voltage
- Motor nominal current
- Motor nominal frequency
- Motor nominal speed
- Motor nominal power

Note: In case of missing or inaccurate information, do not operate the motor before ensuring correct settings!

ABB recommends using all the suitable protective features provided by the converter to improve the safety of the application. Converters usually provide features such as (names and availability of features depend on manufacturer and model of the converter):

- Minimum speed
- Maximum speed
- Acceleration and deceleration times
- Maximum current
- Maximum Torque
- Stall protection

## 6. Maintenance

### WARNING

Voltage may be connected at standstill inside the terminal box for heating elements or direct winding heating.

### WARNING

The capacitor in single-phase motors can retain a charge that appears across the motor terminals, even when the motor has reached standstill.

### WARNING

A motor with frequency converter supply may energize even if the motor is at standstill.

### 6.1 General inspection

1. Inspect the motor at regular intervals, at least once a year. The frequency of checks depends on, for example, the humidity level of the ambient air and on the local weather conditions. This can initially be determined experimentally and must then be strictly adhered to.
2. Keep the motor clean and ensure free ventilation airflow. If the motor is used in a dusty environment, the ventilation system must be regularly checked and cleaned.
3. Check the condition of shaft seals (e.g. V-ring or radial seal) and replace if necessary.
4. Check the condition of connections and mounting and assembly bolts.
5. Check the bearing condition by listening for any unusual noise, vibration measurement, bearing temperature, inspection of spent grease or SPM bearing monitoring. Pay special attention to bearings when their calculated rated life time is coming to an end.

When signs of wear are noticed, dismantle the motor, check the parts and replace if necessary. When bearings are changed, replacement bearings must be of the same type as those originally fitted. The shaft seals have to be replaced with seals of the same quality and characteristics as the originals when changing bearings.

In the case of the IP 55 motor and when the motor has been delivered with a plug closed, it is advisable to periodically open the drain plugs in order to ensure that the way out for condensation is not blocked and allows condensation to escape from the motor. This operation must be done when the motor is at a standstill and has been made safe to work on.

#### 6.1.1 Standby motors

If the motor is in standby for a longer period of time on a ship or in other vibrating environment the following measures have to be taken:

1. The shaft must be rotated regularly every 2 weeks (to be reported) by means of start up of the system. In case a start up is not possible, due to any reason, at least the shaft has to be turned by hand in order to achieve a different position once a week. Vibrations caused by other vessel's equipment will cause bearing pitting which should be minimized by regular operation / hand turning.
2. The bearing must be greased while rotating the shaft every year (to be reported). If the motor has been provided with roller bearing at the driven end the transport lock to be removed before rotating the shaft. The transport locking must be remounted in case of transportation.
3. All vibrations must be avoided to prevent a bearing from failuring. All instructions in the motor instruction manual for commissioning and maintenance have to be followed additionally. The warranty will not cover the winding and bearing damages if these instructions have not been followed.

### 6.2 Lubrication

#### WARNING

Beware of all rotating parts!

#### WARNING

Grease can cause skin irritation and eye inflammation. Follow all safety precautions specified by the manufacturer.

Bearing types are specified in the respective product catalogs and on the rating plate of all motors except smaller frame sizes.

Reliability is a vital issue for bearing lubrication intervals. ABB uses mainly the  $L_1$ -principle (i.e. that 99% of the motors are certain to make the life time) for lubrication.

#### 6.2.1 Machines with permanently greased bearings

Bearings are usually permanently greased bearings of 1Z, 2Z, 2RS or equivalent types.

As a guide, adequate lubrication for sizes up to 250 can be achieved for the following duration, according to  $L_{10}$ .

Duty hours for permanently greased bearings at ambient temperatures of 25 and 40° C are:

### Lubrication intervals according to L<sub>10</sub> principle

Frame size	Poles	Duty hours at 25° C	Duty hours at 40° C
56-63	2-8	40 000	40 000
71	2	40 000	40 000
71	4-8	40 000	40 000
80-90	2	40 000	40 000
80-90	4-8	40 000	40 000
100-112	2	40 000	32 000
100-112	4-8	40 000	40 000
132	2	40 000	27 000
132	4-8	40 000	40 000
160	2	40 000	36 000
160	4-8	40 000	40 000
180	2	38 000	38 000
180	4-8	40 000	40 000
200	2	27 000	27 000
200	4-8	40 000	40 000
225	2	23 000	18 000
225	4-8	40 000	40 000
250	2	16 000	13 000
250	4-8	40 000	39 000

Data valid at 50 Hz, for 60 Hz reduce values for 20 %.

These values are valid for permitted load values given in the product catalog. Depending on application and load conditions, see the applicable product catalog or contact ABB.

Operation hours for vertical motors are half of the above values.

### 6.2.2 Motors with regreasable bearings

#### Lubrication information plate and general lubrication advice

If the machine is equipped with a lubrication information plate, follow the given values.

On the lubrication information plate, greasing intervals regarding mounting, ambient temperature and rotational speed are defined.

During the first start or after a bearing lubrication a temporary temperature rise may appear, approximately 10 to 20 hours.

Some motors may be equipped with a collector for old grease. Follow the special instructions given for the equipment.

#### A. Manual lubrication

##### Regreasing while the motor is running

- Remove grease outlet plug or open closing valve if fitted.
- Be sure that the lubrication channel is open
- Inject the specified amount of grease into the bearing.

- Let the motor run for 1-2 hours to ensure that all excess grease is forced out of the bearing. Close the grease outlet plug or closing valve if fitted.

##### Regreasing while the motor is at a standstill

If it is not possible to regrease the bearings while the motors are running, lubrication can be carried out while the machine is at a standstill.

- In this case use only half the quantity of grease and then run the motor for a few minutes at full speed.
- When the motor has stopped, apply the rest of the specified amount of grease to the bearing.
- After 1-2 running hours close the grease outlet plug or closing valve if fitted.

#### B. Automatic lubrication

The grease outlet plug must be removed permanently with automatic lubrication or open closing valve if fitted.

ABB recommends only the use of electromechanical systems.

The amount of grease per lubrication interval stated in the table should be multiplied by four if an automatic regreasing system is used.

When 2-pole motors are automatically regreased, the note concerning lubricant recommendations for 2-pole motors in the Lubricants chapter should be followed.

### 6.2.3 Lubrication intervals and amounts

As a guide, adequate lubrication for motors with regreasable bearings can be achieved for the following duration, according to L<sub>1</sub>. For duties with higher ambient temperatures please contact ABB. The formula to change the L<sub>1</sub> values roughly to L<sub>10</sub> values: L<sub>10</sub> = 2.7 x L<sub>1</sub>.

Lubrication intervals for vertical machines are half of the values shown in the table below.

The lubrication intervals are based on an ambient temperature +25°C. An increase in the ambient temperature raises the temperature of the bearings correspondingly. The values should be halved for a 15°C increase and may be doubled for a 15°C decrease.

In variable speed operation (i.e. frequency converter supply) it is necessary to measure the bearing temperature for the whole duty range and if exceeds 80°C, the lubrication intervals should be halved for a 15°C increase in bearing temperature. If the motor is operated at high speeds, it is also possible to utilize so called high speed greases, see chapter 6.2.4.

#### WARNING

The maximum operating temperature of the grease and bearings, +110°C, must not be exceeded. The designed maximum speed of the motor must not be exceeded.

## Lubrication intervals according to L<sub>1</sub> principle

Frame size	Amount of grease g/bearing	kW	3600 r/min	3000 r/min	kW	1800 r/min	1500 r/min	kW	1000 r/min	kW	500-900 r/min
<b>Ball bearings</b>											
<b>Lubrication intervals in duty hours</b>											
112	10	all	10000	13000	all	18000	21000	all	25000	all	28000
132	15	all	9000	11000	all	17000	19000	all	23000	all	26500
160	25	≤ 18,5	9000	12000	≤ 15	18000	21500	≤ 11	24000	all	24000
160	25	> 18,5	7500	10000	> 15	15000	18000	> 11	22500	all	24000
180	30	≤ 22	7000	9000	≤ 22	15500	18500	≤ 15	24000	all	24000
180	30	> 22	6000	8500	> 22	14000	17000	> 15	21000	all	24000
200	40	≤ 37	5500	8000	≤ 30	14500	17500	≤ 22	23000	all	24000
200	40	> 37	3000	5500	> 30	10000	12000	> 22	16000	all	20000
225	50	≤ 45	4000	6500	≤ 45	13000	16500	≤ 30	22000	all	24000
225	50	> 45	1500	2500	> 45	5000	6000	> 30	8000	all	10000
250	60	≤ 55	2500	4000	≤ 55	9000	11500	≤ 37	15000	all	18000
250	60	> 55	1000	1500	> 55	3500	4500	> 37	6000	all	7000
280 <sup>1)</sup>	60	all	2000	3500	-	-	-	-	-	-	-
280 <sup>1)</sup>	60	-	-	-	all	8000	10500	all	14000	all	17000
280	35	all	1900	3200	-	-	-	-	-	-	-
280	40	-	-	-	all	7800	9600	all	13900	all	15000
315	35	all	1900	3200	-	-	-	-	-	-	-
315	55	-	-	-	all	5900	7600	all	11800	all	12900
355	35	all	1900	3200	-	-	-	-	-	-	-
355	70	-	-	-	all	4000	5600	all	9600	all	10700
400	40	all	1500	2700	-	-	-	-	-	-	-
400	85	-	-	-	all	3200	4700	all	8600	all	9700
450	40	all	1500	2700	-	-	-	-	-	-	-
450	95	-	-	-	all	2500	3900	all	7700	all	8700

<b>Roller bearings</b>											
<b>Lubrication intervals in duty hours</b>											
160	25	≤ 18,5	4500	6000	≤ 15	9000	10500	≤ 11	12000	all	12000
160	25	> 18,5	3500	5000	> 15	7500	9000	> 11	11000	all	12000
180	30	≤ 22	3500	4500	≤ 22	7500	9000	≤ 15	12000	all	12000
180	30	> 22	3000	4000	> 22	7000	8500	> 15	10500	all	12000
200	40	≤ 37	2750	4000	≤ 30	7000	8500	≤ 22	11500	all	12000
200	40	> 37	1500	2500	> 30	5000	6000	> 22	8000	all	10000
225	50	≤ 45	2000	3000	≤ 45	6500	8000	≤ 30	11000	all	12000
225	50	> 45	750	1250	> 45	2500	3000	> 30	4000	all	5000
250	60	≤ 55	1000	2000	≤ 55	4500	5500	≤ 37	7500	all	9000
250	60	> 55	500	750	> 55	1500	2000	> 37	3000	all	3500
280 <sup>1)</sup>	60	all	1000	1750	-	-	-	-	-	-	-
280 <sup>1)</sup>	70	-	-	-	all	4000	5250	all	7000	all	8500
280	35	all	900	1600	-	-	-	-	-	-	-
280	40	-	-	-	all	4000	5300	all	7000	all	8500
315	35	all	900	1600	-	-	-	-	-	-	-
315	55	-	-	-	all	2900	3800	all	5900	all	6500
355	35	all	900	1600	-	-	-	-	-	-	-
355	70	-	-	-	all	2000	2800	all	4800	all	5400
400	40	all	-	1300	-	-	-	-	-	-	-
400	85	-	-	-	all	1600	2400	all	4300	all	4800
450	40	all	-	1300	-	-	-	-	-	-	-
450	95	-	-	-	all	1300	2000	all	3800	all	4400

1) M3AA

For motors M4BP 160 to 250 the interval may be increased by 30 %, up to a maximum of three calendar years. The values in table above are valid also for sizes M4BP 280 to 355.

## 6.2.4 Lubricants

### WARNING

#### Do not mix different types of grease.

Incompatible lubricants may cause bearing damage.

When regreasing, use only special ball bearing grease with the following properties:

- good quality grease with lithium complex soap and with mineral- or PAO-oil
- base oil viscosity 100-160 cST at 40°C
- consistency NLGI grade 1.5 - 3 \*)
- temperature range -30°C - +120°C, continuously.

\*) For vertical mounted motors or in hot conditions a stiffer end of scale is recommended.

The above mentioned grease specification is valid if the ambient temperature is above -30°C or below +55°C, and the bearing temperature is below 110°C; otherwise consult ABB regarding suitable grease.

Grease with the correct properties is available from all the major lubricant manufacturers.

Admixtures are recommended, but a written guarantee must be obtained from the lubricant manufacturer, especially concerning EP admixtures, that admixtures do not damage bearings or the properties of lubricants at the operating temperature range.

### WARNING

Lubricants containing EP admixtures are not recommended in high bearing temperatures in frame sizes 280 to 450.

The following high performance greases can be used:

- Esso Unirex N2 or N3 (lithium complex base)
- Mobil Mobilith SHC 100 (lithium complex base)
- Shell Gadus S5 V 100 2 (lithium complex base)
- Klüber Klüberplex BEM 41-132 (special lithium base)
- FAG Arcanol TEMP110 (lithium complex base)
- Lubcon Turmogrease L 802 EP PLUS (special lithium base)
- Total Multiplex S 2 A (lithium complex base)

### NOTE!

Always use high speed grease for high speed 2-pole machines where the speed factor is higher than 480,000 (calculated as  $D_m \times n$  where  $D_m$  = average bearing diameter, mm;  $n$  = rotational speed, r/min). The high speed grease is also used in motor types M2CA, M2FA, M2CG and M2FG, frame sizes 355 to 400 2-pole machines.

The following greases can be used for high speed cast iron motors but not mixed with lithium complex greases:

- Klüber Klüber Quiet BQH 72-102 (polyurea base)
- Lubcon Turmogrease PU703 (polyurea base)

If other lubricants are used;

Check with the manufacturer that the qualities correspond to those of the above mentioned lubricants. The lubrication interval are based on the listed high performance greases above. Using other greases can reduce the interval.

If the compatibility of the lubricant is uncertain, contact ABB.

## 7. After Sales Support

### 7.1 Spare parts

When ordering spare parts, the motor serial number, full type designation and product code, as stated on the rating plate, must be specified.

For more information, please visit our web site [www.abb.com/partsonline](http://www.abb.com/partsonline).

### 7.2 Rewinding

Rewinding should always be carried out by qualified repair shops.

Smoke venting and other special motors should not be rewound without first contacting ABB.

### 7.3 Bearings

Special care should be taken with the bearings. These must be removed using pullers and fitted by heating or using special tools for the purpose.

Bearing replacement is described in detail in a separate instruction leaflet available from the ABB Sales Office.

## 8. Environmental requirements

### 8.1 Noise levels

Most of ABB's motors have a sound pressure level not exceeding 82 dB(A) at 50 Hz .

Values for specific machines can be found in the relevant product catalogues. At 60 Hz sinusoidal supply the values are approximately 4 dB(A) higher compared to 50 Hz values in product catalogues.

For sound pressure levels at frequency converter supply, please contact ABB.

Sound pressure levels for all machines having separate cooling systems and for series M2F\*/M3F\*, M2L\*/M3L\*, M2R\*/M3R\*, M2BJ/M3BJ and M2LJ/M3LJ are indicated in separate additional manuals.



## 9. Troubleshooting

These instructions do not cover all details or variations in equipment nor provide for every possible condition to be met in connection with installation, operation or maintenance. Should additional information required, please contact the nearest ABB Sales Office.

### Motor troubleshooting chart

Your motor service and any troubleshooting must be handled by qualified persons who have proper tools and equipment.

TROUBLE	CAUSE	WHAT TO DO
Motor fails to start	Blown fuses	Replace fuses with proper type and rating.
	Overload trips	Check and reset overload in starter.
	Improper power supply	Check to see that power supplied agrees with motor rating plate and load factor.
	Improper line connections	Check connections against diagram supplied with motor.
	Open circuit in winding or control switch	Indicated by humming sound when switch is closed. Check for loose wiring connections. Also ensure that all control contacts are closing.
	Mechanical failure	Check to see if motor and drive turn freely. Check bearings and lubrication.
	Short circuited stator Poor stator coil connection	Indicated by blown fuses. Motor must be rewound. Remove end shields, locate fault.
	Rotor defective	Look for broken bars or end rings.
	Motor may be overloaded	Reduce load.
Motor stalls	One phase may be open	Check lines for open phase.
	Wrong application	Change type or size. Consult equipment supplier.
	Overload	Reduce load.
	Low voltage	Ensure the rating plate voltage is maintained. Check connection.
	Open circuit	Fuses blown, check overload relay, stator and push buttons.
Motor runs and then dies down	Power failure	Check for loose connections to line, to fuses and to control.
Motor does not come up to nominal speed	Not applied properly	Consult equipment supplier for proper type.
	Voltage too low at motor terminals because of line drop	Use higher voltage or transformer terminals or reduce load. Check connections. Check conductors for proper size.
	Starting load too high	Check the start load of the motor.
	Broken rotor bars or loose rotor	Look for cracks near the rings. A new rotor may be required, as repairs are usually temporary.
	Open primary circuit	Locate fault with testing device and repair.

<b>TROUBLE</b>	<b>CAUSE</b>	<b>WHAT TO DO</b>
Motor takes too long to accelerate and/or draws high current	Excessive load	Reduce load.
	Low voltage during start	Check for high resistance. Make sure that adequate cable size is used.
	Defective squirrel cage rotor	Replace with new rotor.
	Applied voltage too low	Correct power supply.
Wrong rotation direction	Wrong sequence of phases	Reverse connections at motor or at switchboard.
Motor overheats while running	Overload	Reduce load.
	Frame or ventilation openings may be full of dirt and prevent proper ventilation of motor	Open vent holes and check for a continuous stream of air from the motor.
	Motor may have one phase open	Check to make sure that all leads are well connected.
	Grounded coil	Motor must be rewound
	Unbalanced terminal voltage	Check for faulty leads, connections and transformers.
Motor vibrates	Motor misaligned	Realign.
	Weak support	Strengthen base.
	Coupling out of balance	Balance coupling.
	Driven equipment unbalanced	Rebalance driven equipment.
	Defective bearings	Replace bearings.
	Bearings not in line	Repair motor.
	Balancing weights shifted	Rebalance motor.
	Contradiction between balancing of rotor and coupling (half key - full key)	Rebalance coupling or motor.
	Polyphase motor running single phase	Check for open circuit.
Excessive end play	Adjust bearing or add shim.	
Scraping noise	Fan rubbing end shield or fan cover	Correct fan mounting.
	Loose on bedplate	Tighten holding bolts.
Noisy operation	Air gap not uniform	Check and correct end shield fits or bearing fits.
	Rotor unbalance	Rebalance rotor.
Hot bearings	Bent or sprung shaft	Straighten or replace shaft.
	Excessive belt pull	Decrease belt tension.
	Pulleys too far away from shaft shoulder	Move pulley closer to motor bearing.
	Pulley diameter too small	Use larger pulleys.
	Misalignment	Correct by realignment of the drive.
	Insufficient grease	Maintain proper quality and amount of grease in bearing.
	Deterioration of grease or lubricant contaminated	Remove old grease, wash bearings thoroughly in kerosene and replace with new grease.
	Excess lubricant	Reduce quantity of grease, bearing should not be more than half full.
	Overloaded bearing	Check alignment, side and end thrust.
Broken ball or rough races	Replace bearing, clean housing thoroughly first.	

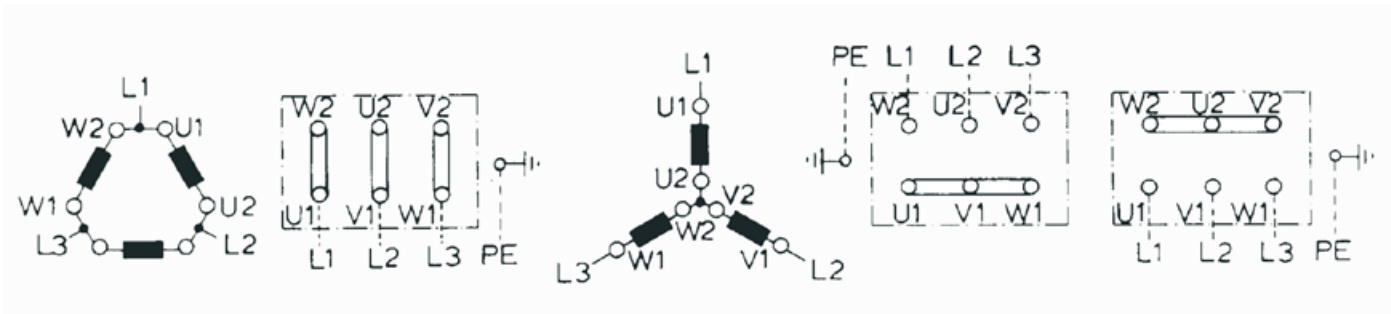

Figure 1. Connection diagram  
 Bild 1. Anschlußdiagramm  
 Figure 1. Connection  
 Figura 1. Conexión  
 Figura 1. Collegamento  
 Figura 1. Diagrama de ligações  
 Figur 1. Anslutningdiagramm  
 Kuva 1. KytKentäkaavio

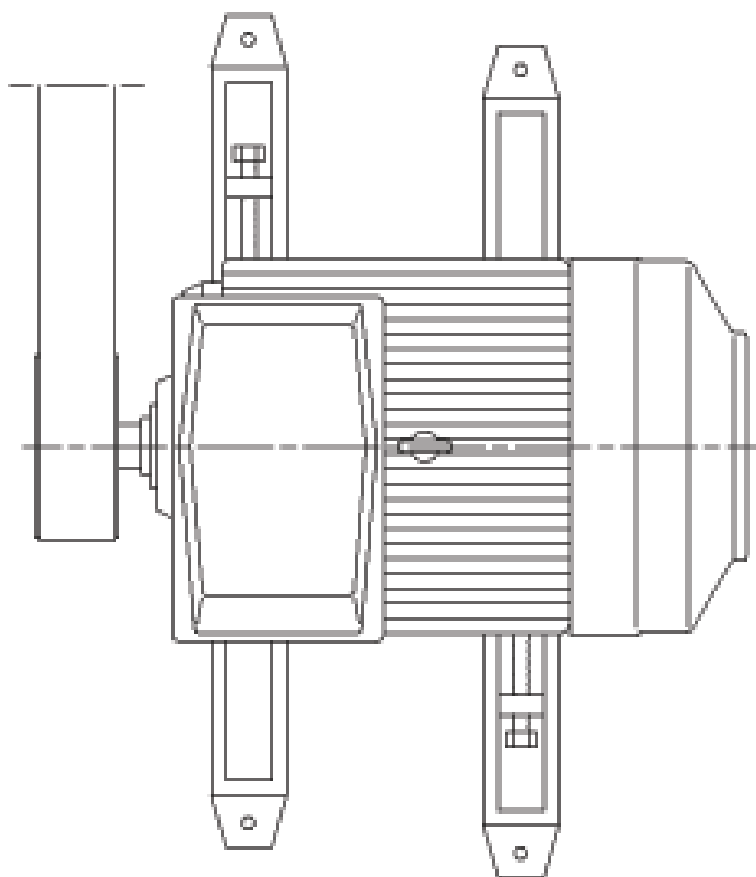

Figure 2. Belt drive  
 Bild 2. Riemetrieb  
 Figure 2. Glissières et entraînements à courroie  
 Figure 2. Carriles tensores y correas  
 Figura 2. Slitte tendicinghia e pulegge  
 Figura 2. Transmissão por correias  
 Figur 2. Remdrift  
 Kuva 2. Hihnakäyttö

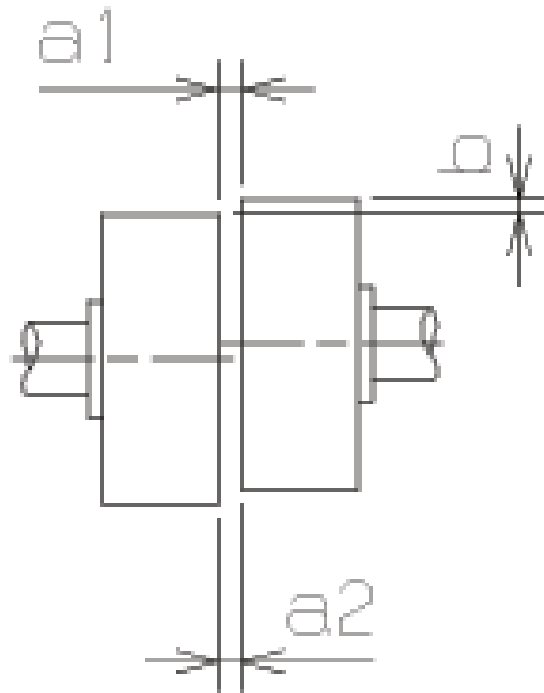

Figure 3. Mounting of half-coupling or pulley

Bild 3. Anbau von Kupplungshälften und Riemenscheiben

Figure 3. Montage des demi-accouplements et des poulies

Figura 3. Montaje de mitades de acoplamiento y poleas

Figura 3. Montaggio di semigiunti e pulegge

Figura 3. Montagem de meio acoplamento ou poleia

Figur 3. Montering av kopplinshalvor och drivskivor

Kuva 3. Kytkinpuolikkaan ja hihnapyörän asennus

**Loadability curves with ACS800 converters with DTC control**  
**Belastbarkeitskurven für ACS800-Frequenzumrichter mit DTC-Steuerung**  
**Courbes de capacité de charge avec convertisseurs ACS800 et commande DTC**  
**Curvas de capacidad de carga con convertidores ACS800 dotados de control DTC**  
**Curve di caricabilità con convertitori ACS800 e controllo DTC**  
**Curvas de capacidade de carga com conversores ACS800 com controle de transmissão digital (DTC)**  
**Lastbarhetskurvor för ACS800-omriktare med DTC-styrning**  
**Kuormitettavuuskäyrät DTC-säädöllä varustetuille ACS800-taajuusmuuttajille**

Figures/Abbildungen/Figures/Figure/Figure/Figuras/Figur/Kuvat 4a, 4b, 4c, 4d

Low voltage motors, nominal frequency of the motors 50/60 Hz, temperature rise B/F  
 Niederspannungsmotoren, Nennfrequenz der Motoren 50/60 Hz, Temperaturanstieg B/F  
 Moteurs à basse tension, fréquence nominale des moteurs de 50/60 Hz, augmentation de température B/F  
 Motores de baja tensión, frecuencia nominal de los motores 50/60 Hz, aumento de temperatura B/F  
 Motori a bassa tensione, frequenza nominale dei motori 50/60 Hz, incremento di temperatura B/F  
 Motores de baixa tensão, frequência nominal dos motores 50/60 Hz, aumento da temperatura B/F  
 Lågspänningsmotorer, märkfrekvens för motorerna 50/60 Hz, temperaturstegring B/F  
 Pienjännitemoottorit, moottorin nimellistaajuus 50/60 Hz, lämpötilan nousu B/F

**4a ACS800/50 Hz, Temperature rise B**

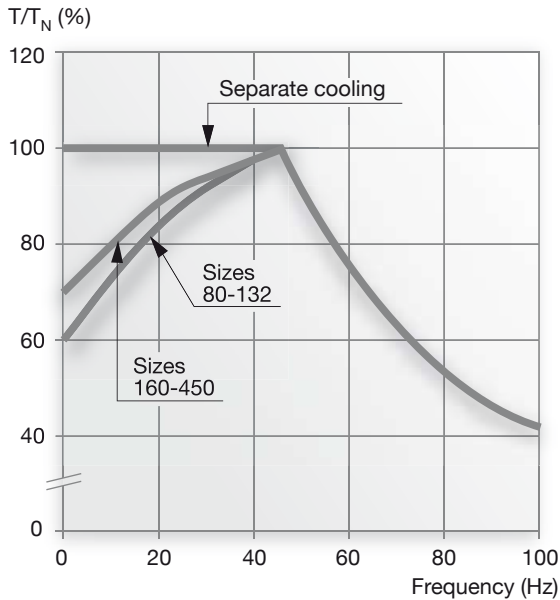

**4b ACS800/60 Hz, Temperature rise B**

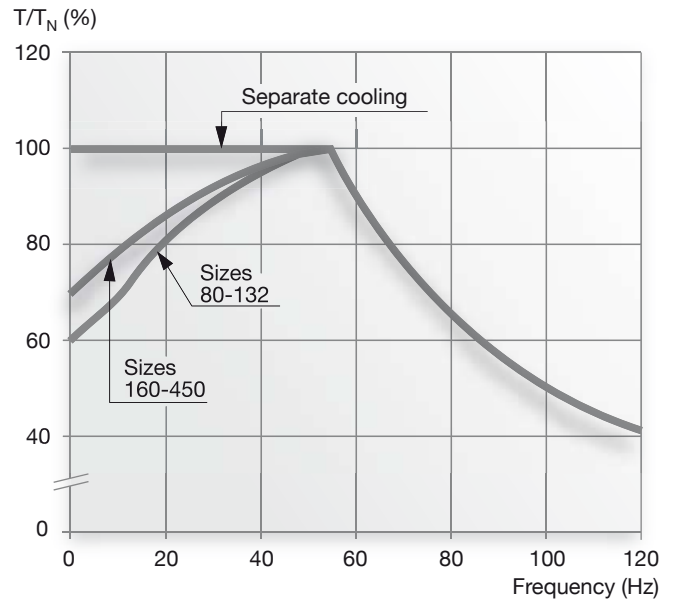

**4c ACS800/50 Hz, Temperature rise F**

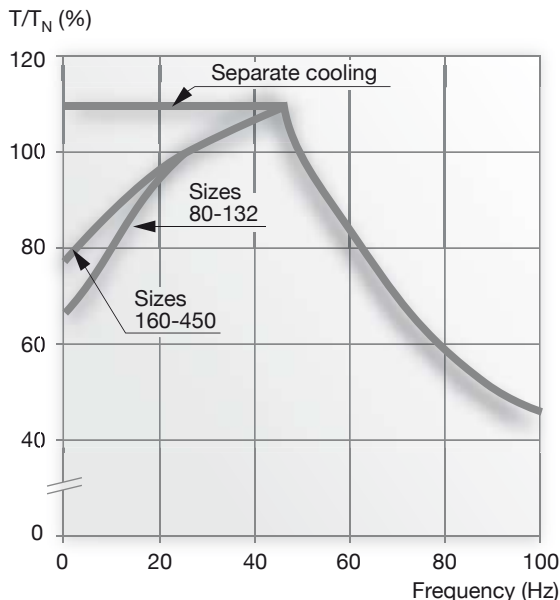

**4d ACS800/60 Hz, Temperature rise F**

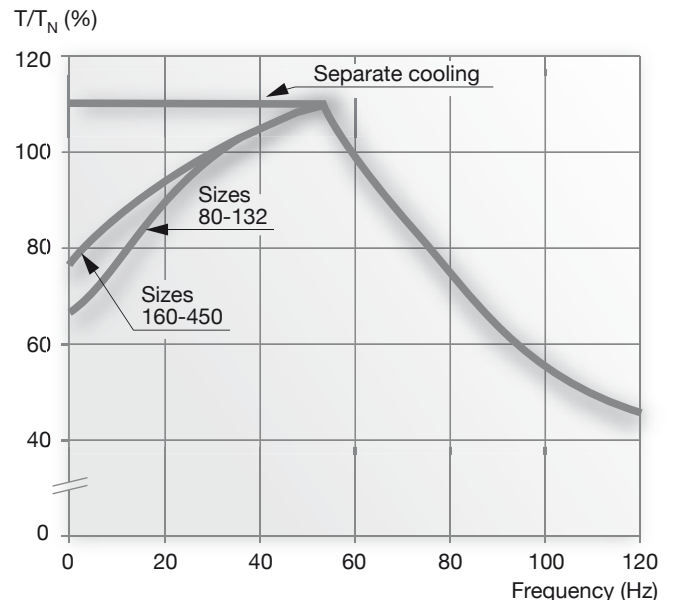

**Loadability curves with ACS550 converters**  
**Belastbarkeitskurven für ACS550-Frequenzumrichter**  
**Courbes de capacité de charge avec convertisseurs ACS550**  
**Curvas de capacidad de carga con convertidores ACS550**  
**Curve di caricabilità con convertitori ACS550**  
**Curvas de capacidade de carga com conversores ACS550**  
**Lastbarhetskurvor för ACS550-omriktare**  
**Kuormitettavuuskäyrät ACS550-taajuusmuuttajille**

Figures/Abbildungen/Figures/Figure/Figure/Figuras/Figur/Kuvat 5a, 5b, 5c, 5d

Low voltage motors, nominal frequency of the motors 50/60 Hz, temperature rise B/F  
 Niederspannungsmotoren, Nennfrequenz der Motoren 50/60 Hz, Temperaturanstieg B/F  
 Moteurs à basse tension, fréquence nominale des moteurs de 50/60 Hz, augmentation de température B/F  
 Motores de baja tensión, frecuencia nominal de los motores 50/60 Hz, aumento de temperatura B/F  
 Motori a bassa tensione, frequenza nominale dei motori 50/60 Hz, incremento di temperatura B/F  
 Motores de baixa tensão, frequência nominal dos motores 50/60 Hz, aumento da temperatura B/F  
 Lågspänningsmotorer, märkfrekvens för motorerna 50/60 Hz, temperaturstegring B/F  
 Pienjännitemoottorit, moottorin nimellistaajuus 50/60 Hz, lämpötilan nousu B/F

**5a ACS550/50 Hz, Temperature rise B**

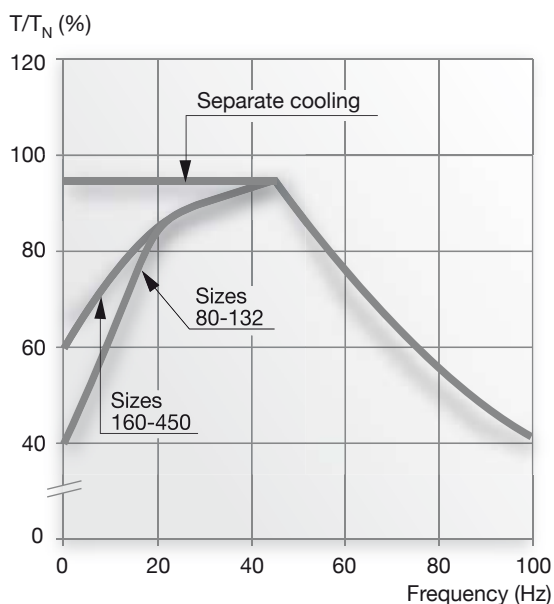

**5b ACS550/60 Hz, Temperature rise B**

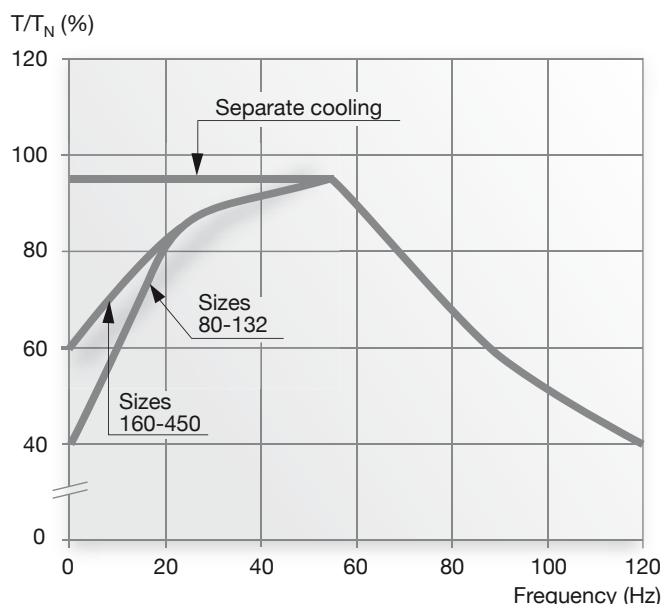

**5c ACS550/50 Hz, Temperature rise F**

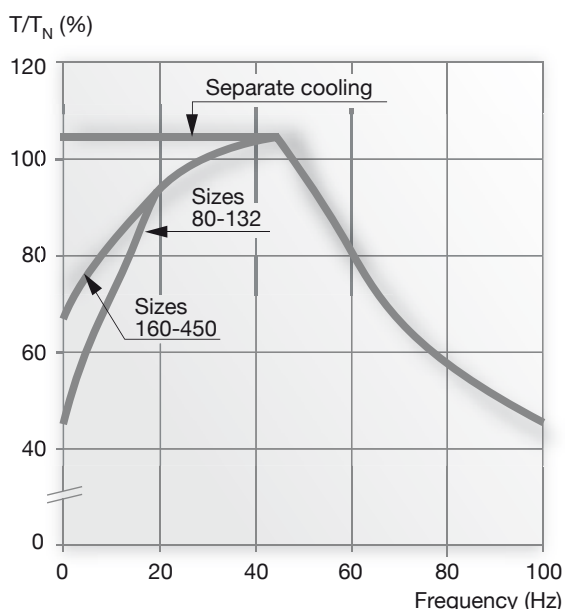

**5d ACS550/60 Hz, Temperature rise F**

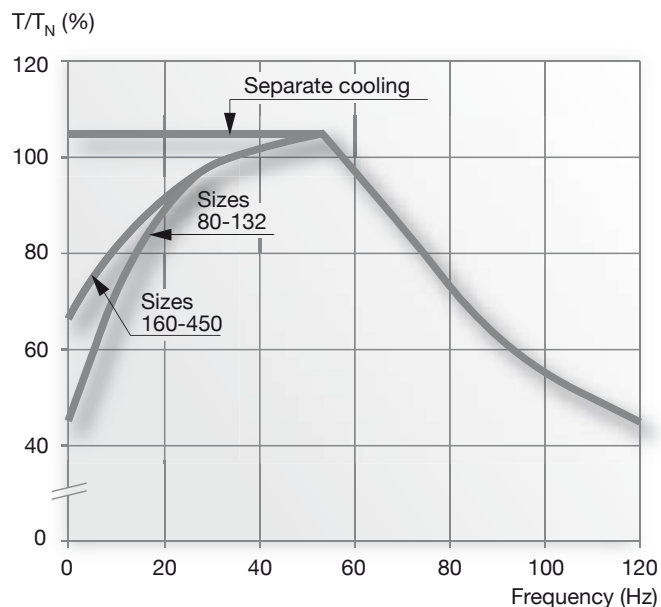

Figure/Bild/Figure/Figura/Figura/Figura/Figur/Kuva 6.

Allowed phase to phase voltage peaks at motor terminal as a function of rise time.

..... ABB Special Insulation; \_\_\_ ABB Standard Insulation

Zulässige Phase-zu-Phase-Spannungsspitzen an Motorklemmen als Funktion der Anstiegszeit.

..... ABB Spezialisolierung; \_\_\_ ABB Standardisolierung

Pics de tension phase-phase au niveau des bornes du moteur en tant que fonction de temps de hausse.

..... ABB Isolation spéciale ; \_\_\_ Isolation standard ABB

Picos de tensión permitidos entre fases en los bornes del motor en función del tiempo de aumento.

..... Aislamiento especial de ABB; \_\_\_ Aislamiento estándar de ABB

Picchi di tensione da fase a fase ammessi ai morsetti del motore in funzione del tempo di salita.

..... Isolamento speciale ABB; \_\_\_ Isolamento standard ABB

Fase permitida para picos de tensão de fase no terminal do motor como função do tempo de subida.

..... Isolamento especial da ABB; \_\_\_ Isolamento normal da ABB

Tillåtna fas till fas-spänningsstoppar vid motoranslutningarna som en funktion av stigtid.

..... ABB Specialisolering; \_\_\_ ABB Standardisolering

Pääjännitteiden suurimmat sallitut piikkiarvot nousunopeuden funktiona.

..... ABB:n erikoiseristys; \_\_\_ ABB:n vakioeristys

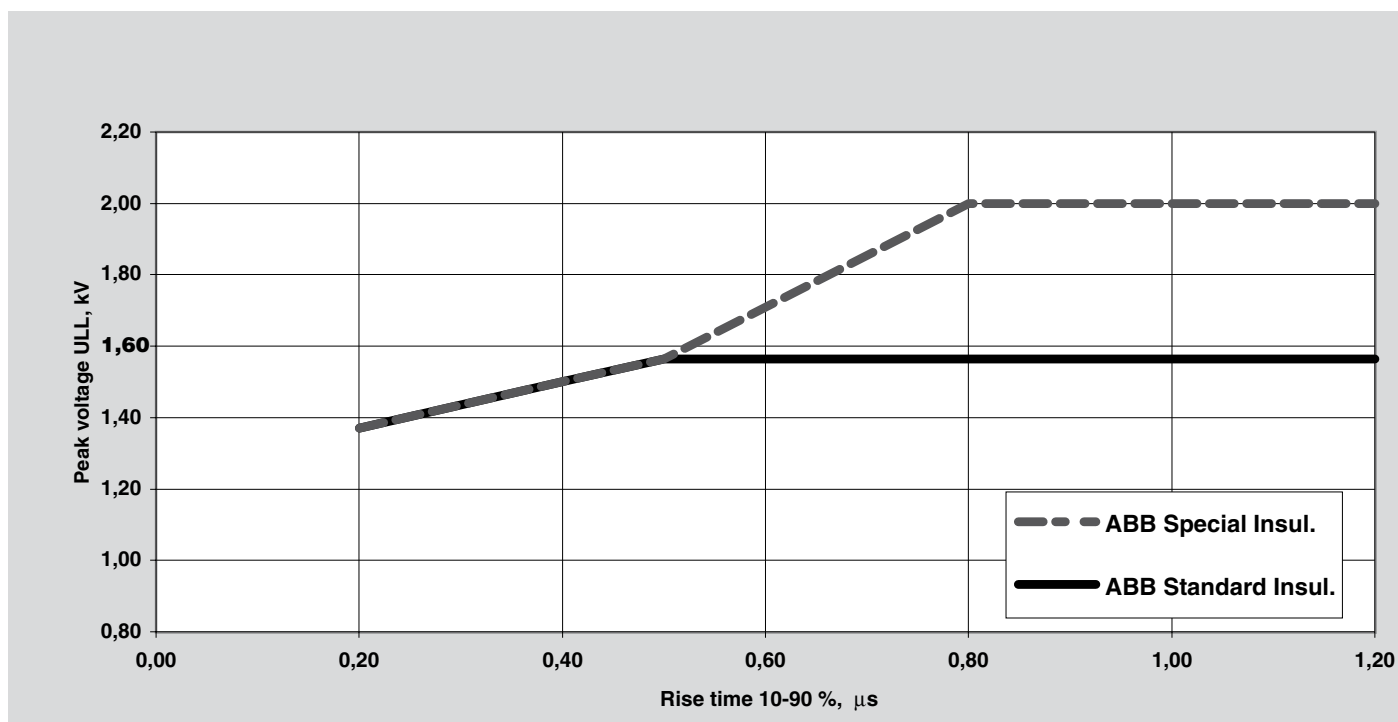





### Product feature

1. Succinct appearance and compact conformation.
2. The installation size is conforms to the ISO 5599/1 standard.
3. Because of the special seals, the feature are large flow rate and long lifetime.
4. You can adjust the installation direction of the pilot O-ring to change the acting type: internal pilot, external pilot, or air control.
5. You need install the valve together with the manifold. There are single type and parallel type for manifold.
6. Various connection and installation method for manifold. It is easy to use.
7. The manifold have the function of exhaust throttling, so no need to connect another throttle valve.

### Ordering code of valve

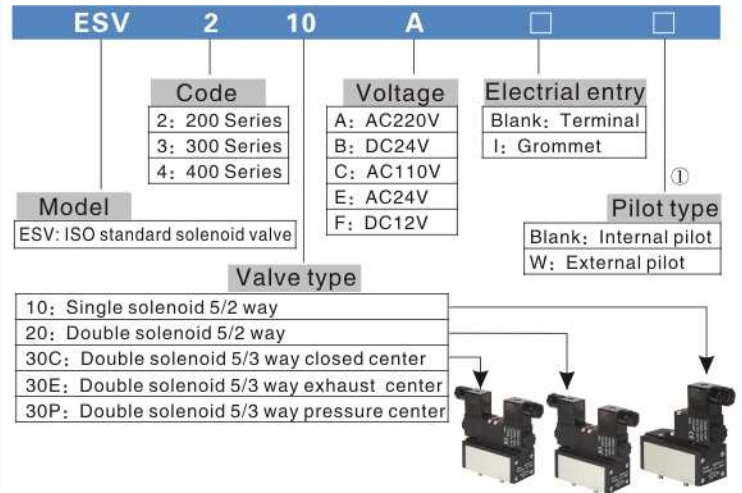

①Note: Internal guided mode can be interchanged with external guided mode, please adjust the installation method of the O-ring referring to article 1 or 2 in the installation manual.

### Symbol

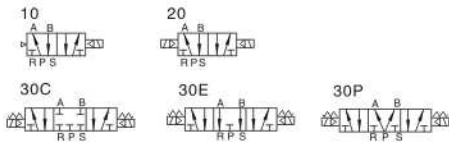

### Specification

Item	Specification
Fluid	Air (to be filtered by 40μm filter element)
Acting	Internal pilot or external pilot
Lubrication	Not required
Pressure	Internal pilot: 0.2~1.0MPa(2~10.0bar)(29~145psi)
	External pilot: 0~1.0MPa(0~10.0bar)(0~145psi)
Control pressure (external pilot)	0.2~1.0MPa(2~10.0bar)(29~145psi)
Proof pressure	1.5MPa(15.0bar)(215psi)
Temperature	-20~70°C
Port size (manifold)	200 Series:1/4" ;300 Series:3/8" ;400 Series:1/2"
Port size (subassembly of plate)	200 Series:3/8" ;300 Series:1/2" ;400 Series:3/4"
Voltage range	AC: ±15% DC: ±10%
Power consumption	AC: 3.5VA DC: 3.0W
Activating time (0.5Mpa)	ESV200 Series: 210, 220 Series:33/41ms; 230 Series:38/50ms
	ESV300 Series: 310, 320 Series:42/55ms; 330 Series:50/62ms
Open/close	ESV400 Series: 50/68ms
Insulation	Class B
Protection	IP65
Service life	30 million times above (normal use)
Installation size	ISO5599-1 standard

### Ordering code of manifold

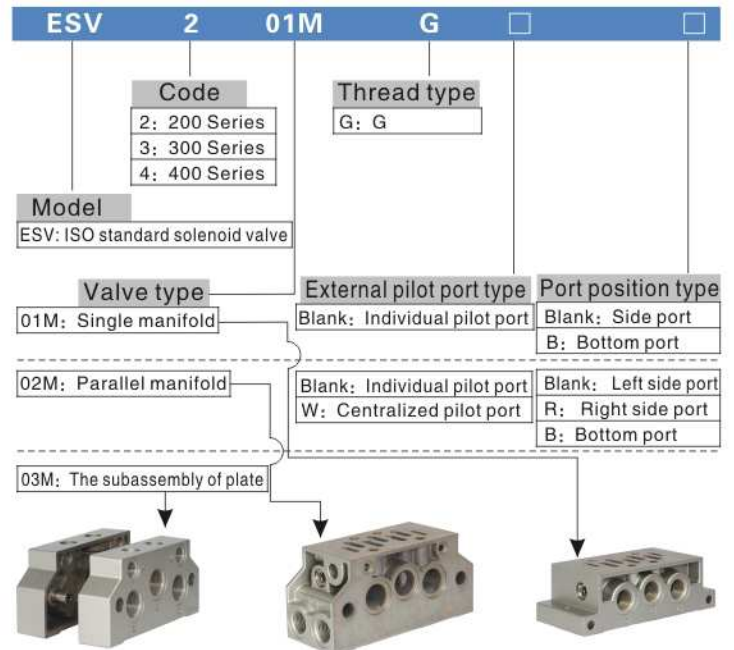

Note:1. For the same model, the port size of plate is bigger than the manifold's (For example ESV202M, the port size of manifold is 1/4", and the subassembly of plate is 3/8").  
2. The external pilot port for Single manifold is individual pilot port.  
3. The subassembly of plate is applied with Parallel manifold, both for individual pilot type and centralized pilot type.

### Ordering code of blanking plate

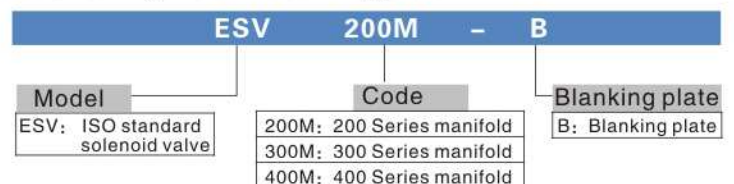



## ESV200~400 Series

### ■ Installation and operation

#### 1、Exhaust throttle function

- 1.1 The manifold have exhaust throttle function, as the below picture shows the position of the exhaust throttle orifices on each side.
- 1.2 Use inner hexagon spanner to adjust the screw.
- 1.3 Rotate the screw clockwise to reduce the exhaust orifice, rotate the screw counter-clockwise to enlarge the exhaust orifice.

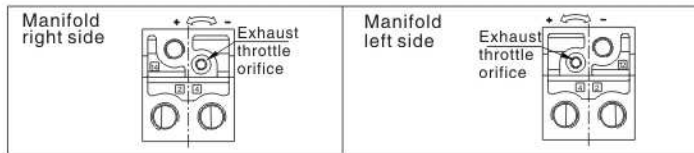

#### 2、The classification and selection for the parallel manifolds

- 2.1、According to the direction of air supply, we can divide the parallel manifold into two types: the individual pilot and centralized pilot.
- 2.2、If you select the individual pilot, the fitting must be connected to the individual pilot ports. If you select the centralized pilot type, the fitting must be connected to the centralized pilot ports.
- 2.3、If you use parallel manifold, all of the manifold must be used the same pilot type: such as, all of them are the individual pilot type, or all of them are the centralized pilot type.

\*Note: Only when you use the external pilot type, you can select the individual pilot or centralized pilot. When you use the internal pilot type, the pilot ports on the manifold are ineffective.

#### 3、The position and specification of the parallel manifolds ports

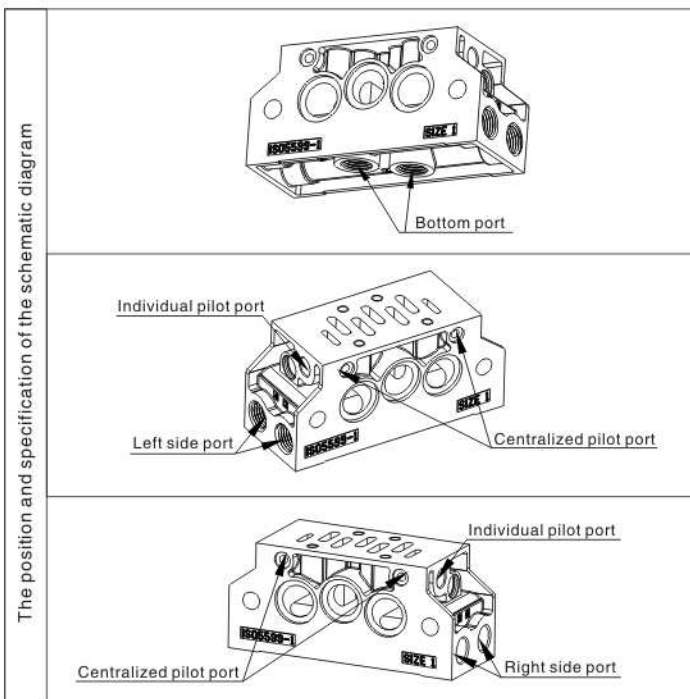

Corresponding tables the ordering code of the parallel manifolds

Port working condition	Port name				
	Left side port	Right side port	Bottom port	Centralized pilot port	Individual pilot port
Ordering code					
ESV202M	Use	Unused	Unused	Unused	Use
ESV202MR	Unused	Use	Unused	Unused	Use
ESV202MB	Unused	Unused	Use	Unused	Use
ESV202MW	Use	Unused	Unused	Use	Unused
ESV202MWR	Unused	Use	Unused	Use	Unused
ESV202MWB	Unused	Unused	Use	Use	Unused

Note: Please seal the bottom port by plug, when it is unused.  
The above list is an example of 200M series' ordering code, the other series is follow the same regulation, only need to change the series code.

#### 4、The classification and selection for the pilot type of valve

- 4.1 According to the source of pilot air, we can divide the valve into two types: the internal pilot and external pilot. The standard type is internal pilot.
- 4.2 You can convert from internal pilot to external pilot by the following methods.

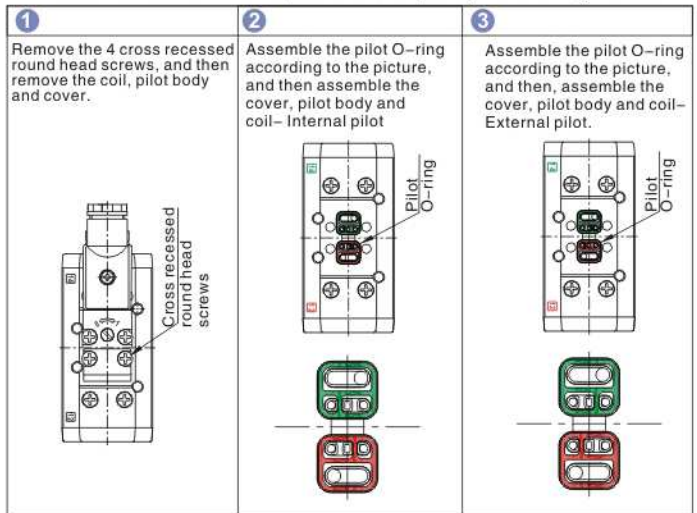

#### ■ Flow chart

Model: ESV210

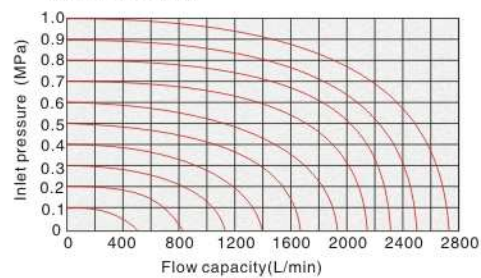

Model: ESV310

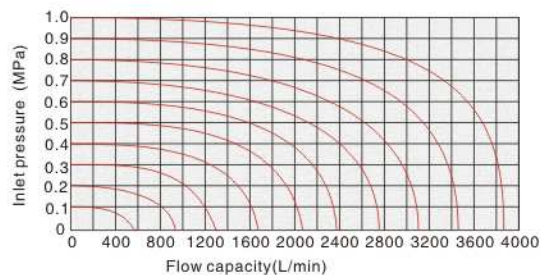

Model: ESV410

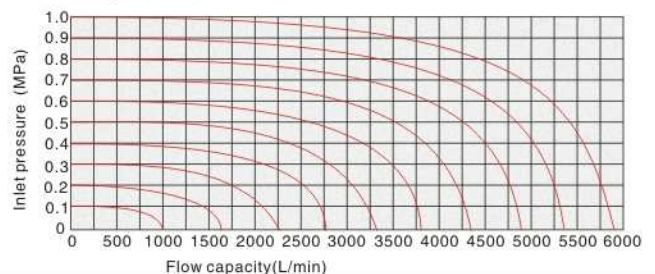

# ISO standard solenoid valve

## ESV200~400 Series

### Inner structure

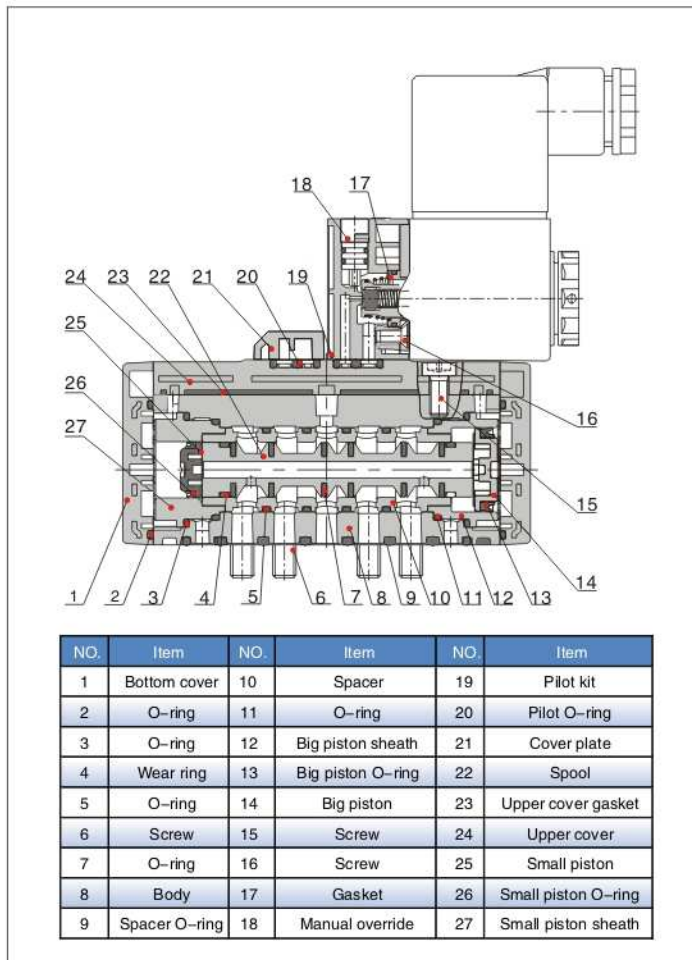

### Dimensions(ESV200 Series)

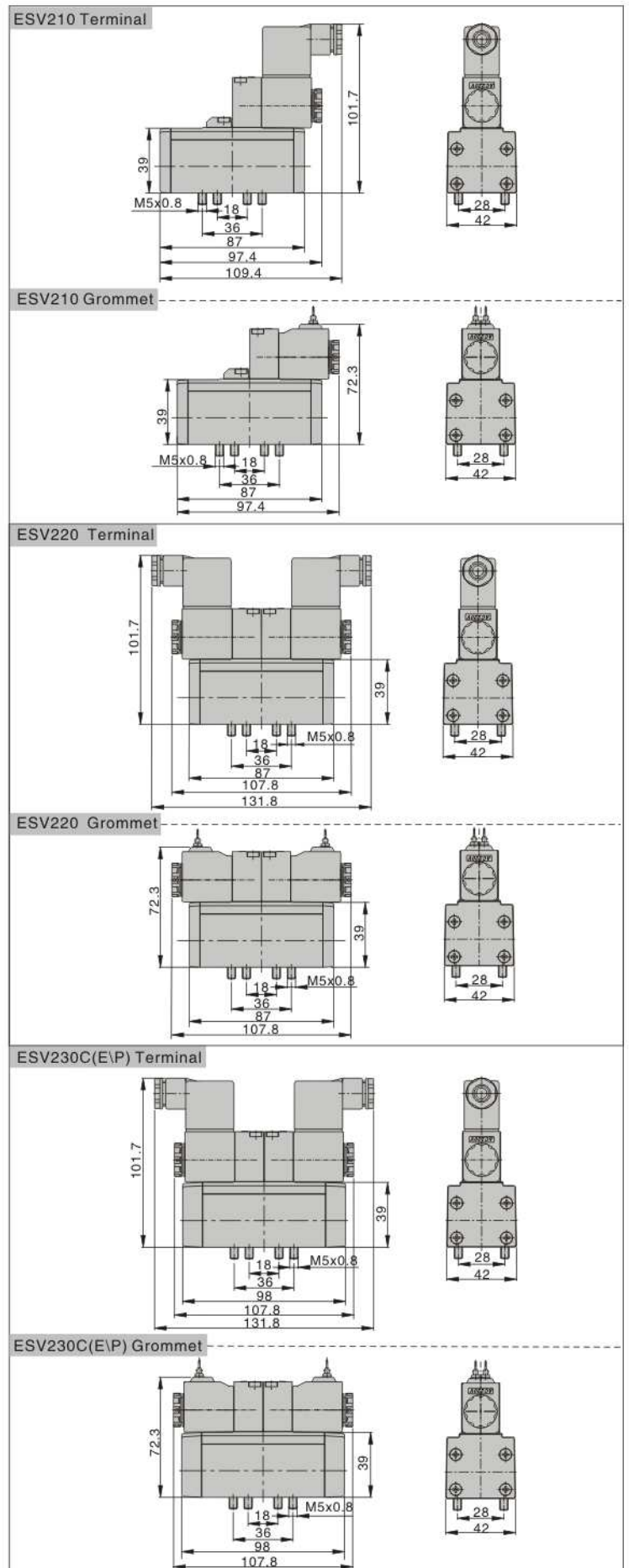



# ISO standard solenoid valve

## ESV200~400 Series

ESV201M

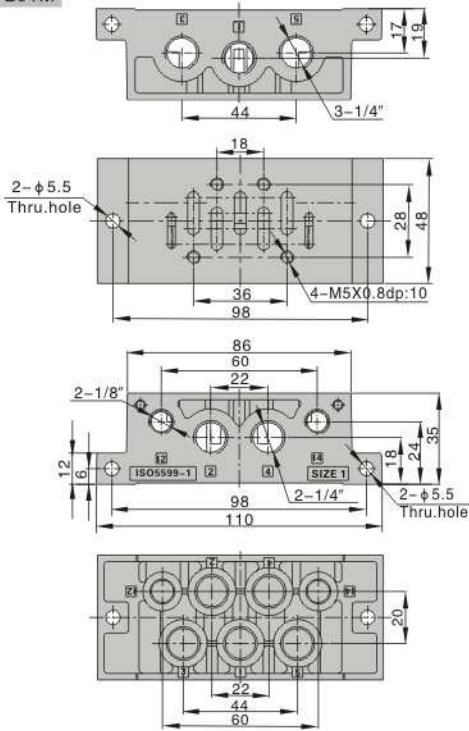

ESV210+ESV201M

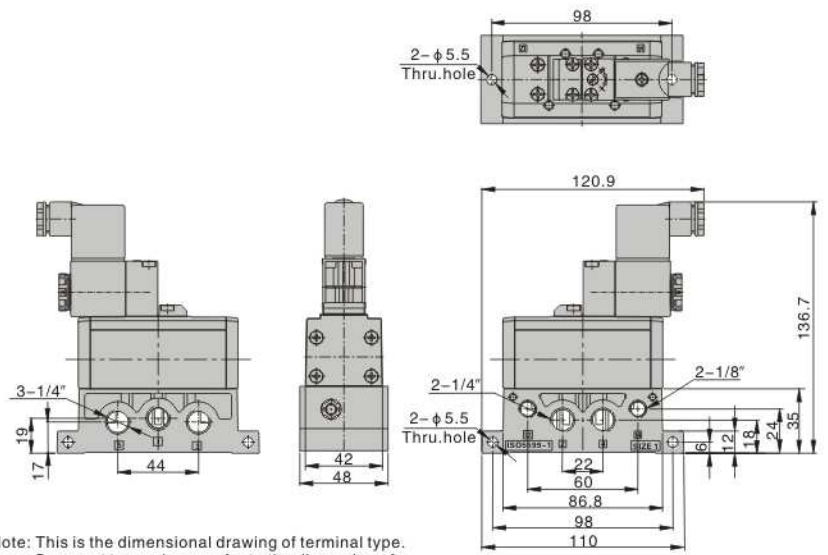

Note: This is the dimensional drawing of terminal type.  
Grommet type, please refer to the dimension of manifold and single grommet valve.

ESV220+ESV201M

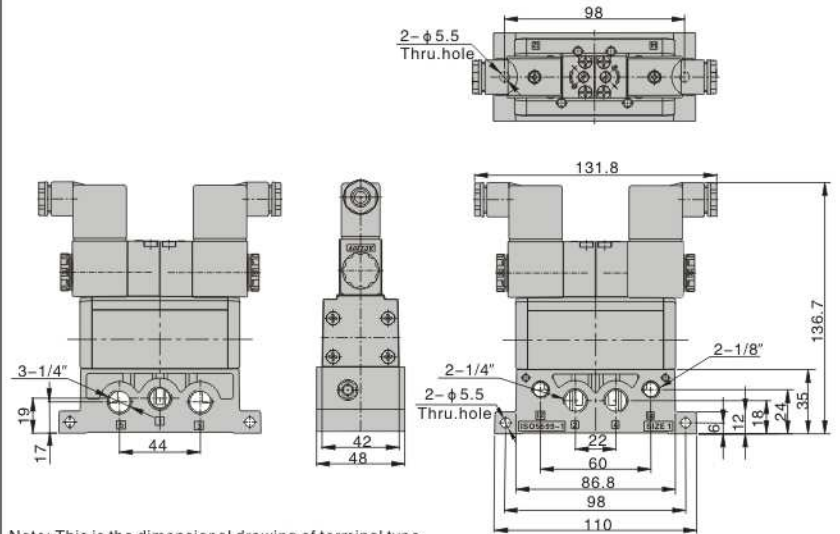

Note: This is the dimensional drawing of terminal type.  
Grommet type, please refer to the dimension of manifold and single grommet valve.

ESV202M

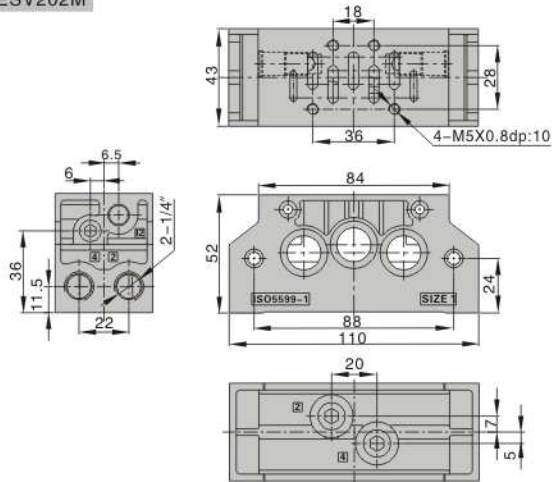

ESV230+ESV201M

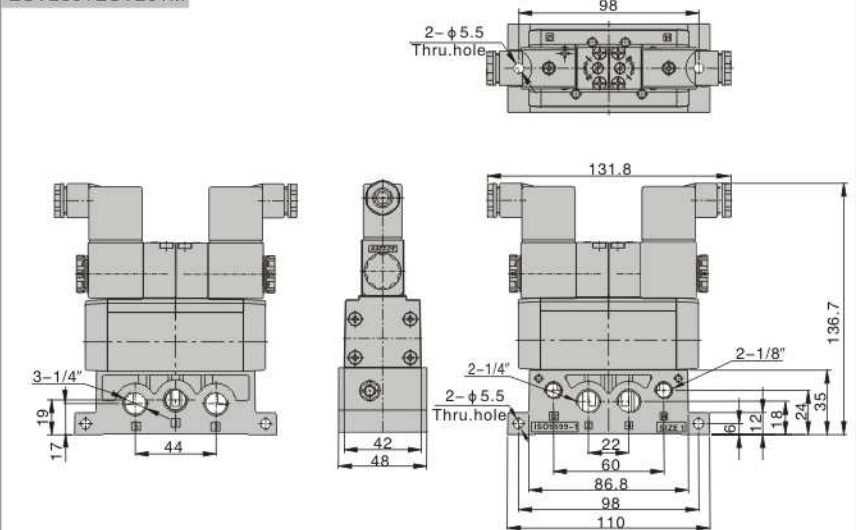

Note: This is the dimensional drawing of terminal type.  
Grommet type, please refer to the dimension of manifold and single grommet valve.

ESV203M

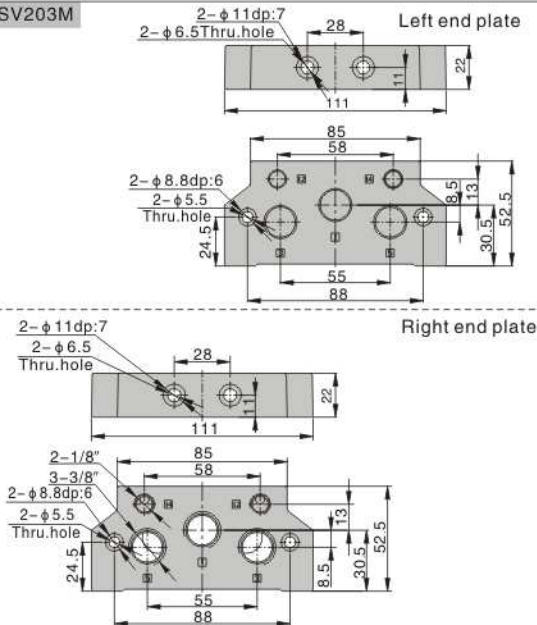

# ISO standard solenoid valve

## ESV200~400 Series

ESV210+ESV202M+ESV203M

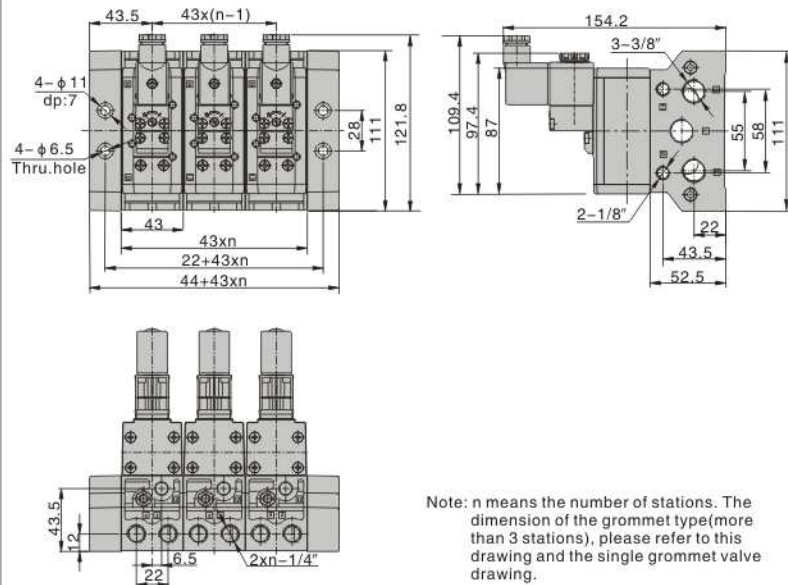

ESV220+ESV202M+ESV203M

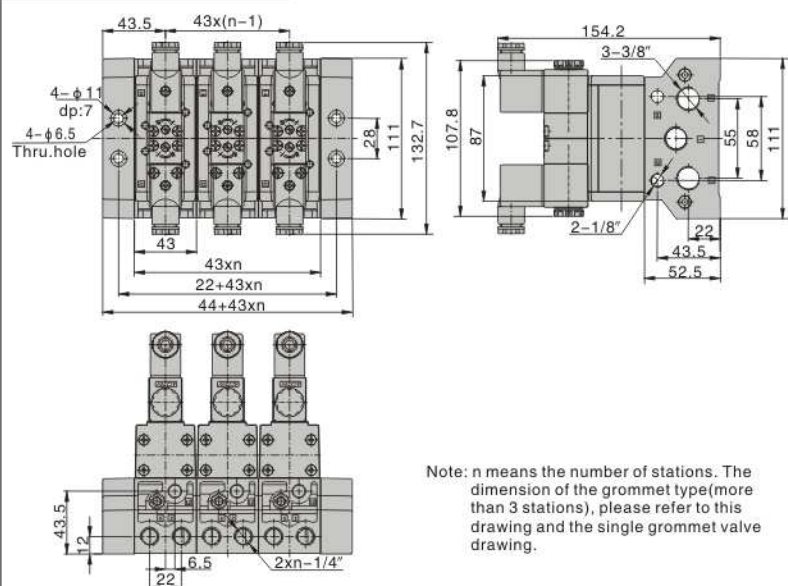

ESV230+ESV202M+ESV203M

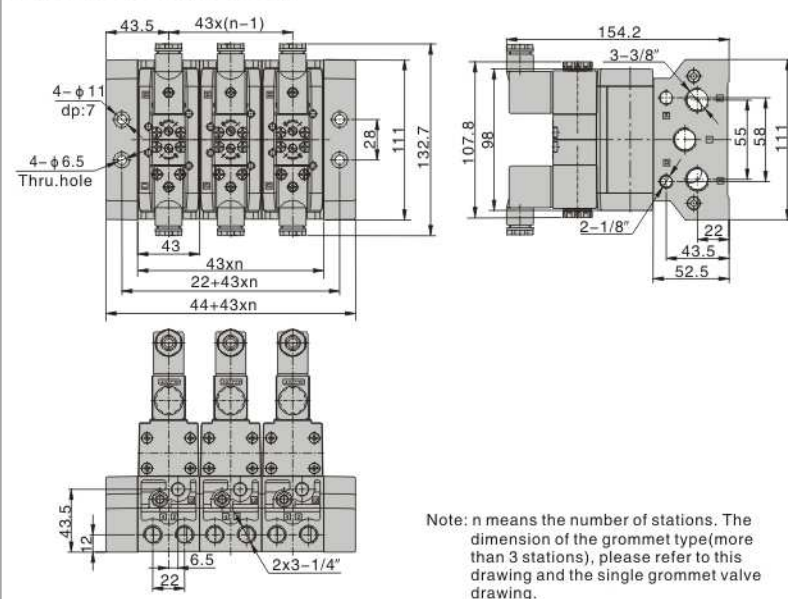

## ■ Dimensions (ESV300 Series)

ESV310 Terminal

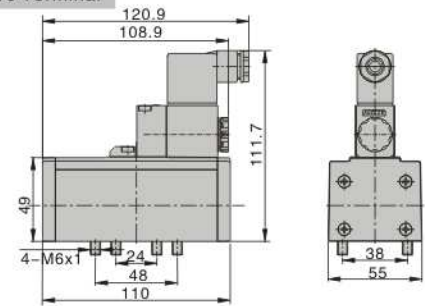

ESV310 Grommet

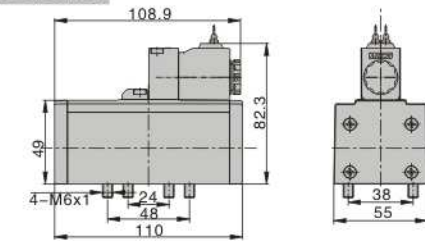

ESV320 Terminal

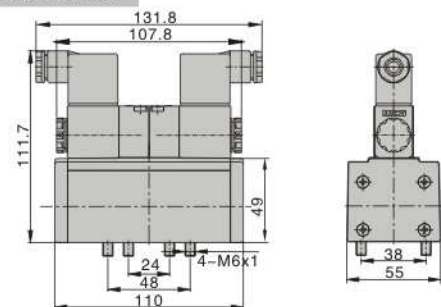

ESV320 Grommet

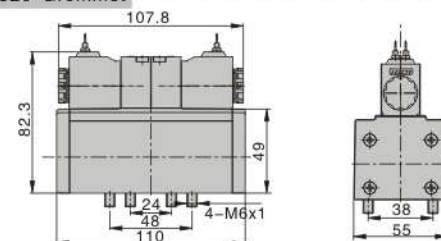

ESV330C(E/P) Terminal

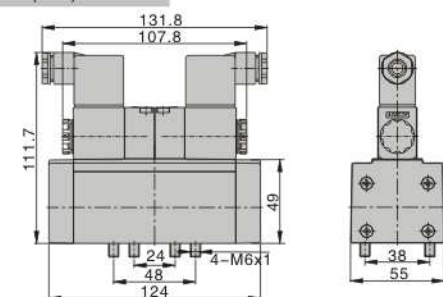

ESV330C(E/P) Grommet

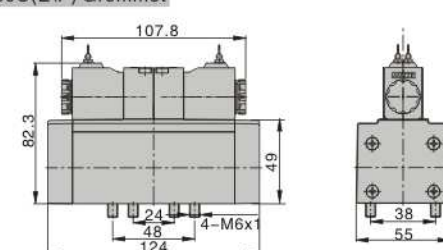



# ISO standard solenoid valve

## ESV200~400 Series

ESV301M

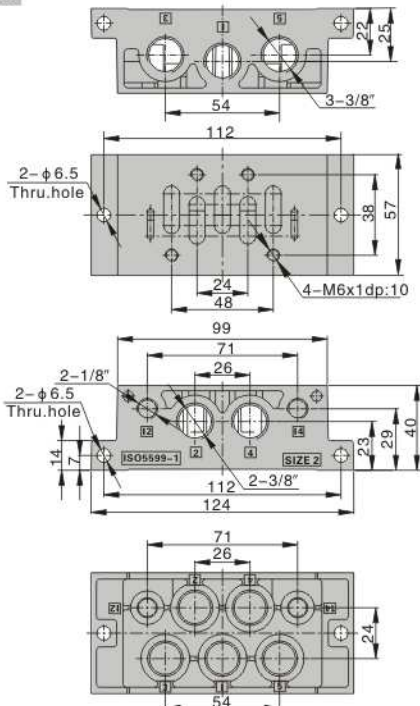

ESV310+ESV301M

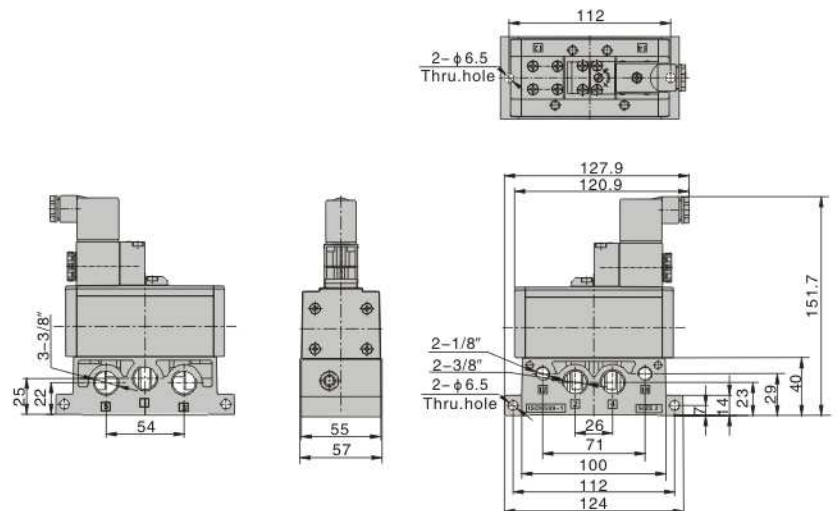

Note: This is the dimensional drawing of terminal type.  
Grommet type, please refer to the dimension of manifold and single grommet valve.

ESV320+ESV301M

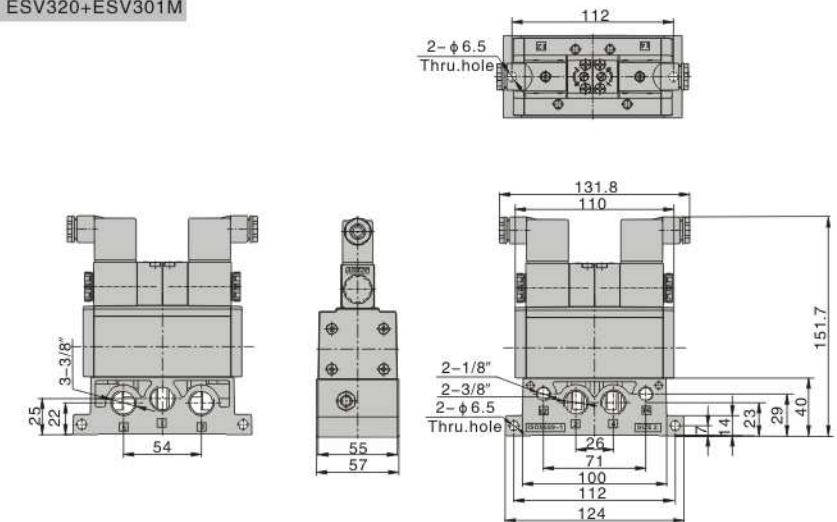

Note: This is the dimensional drawing of terminal type.  
Grommet type, please refer to the dimension of manifold and single grommet valve.

ESV302M

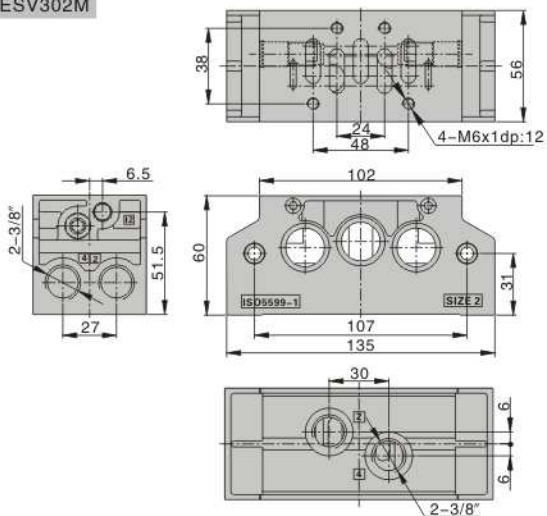

ESV330+ESV301M

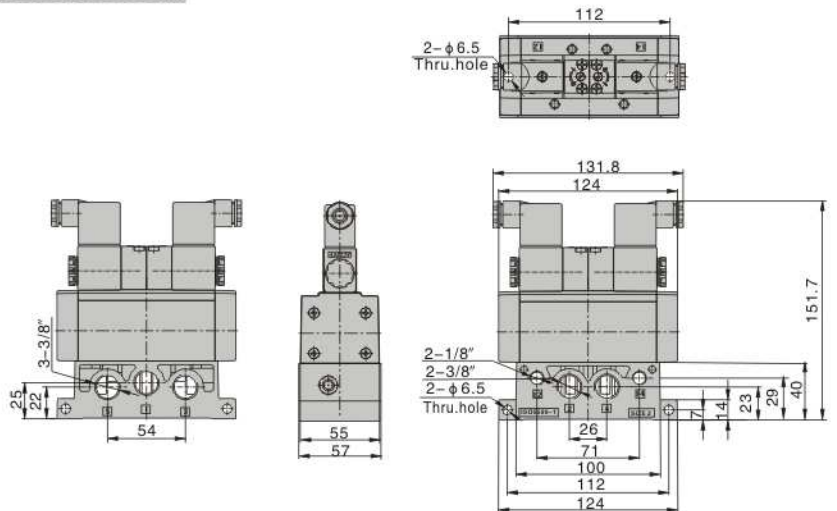

Note: This is the dimensional drawing of terminal type.  
Grommet type, please refer to the dimension of manifold and single grommet valve.

ESV303M

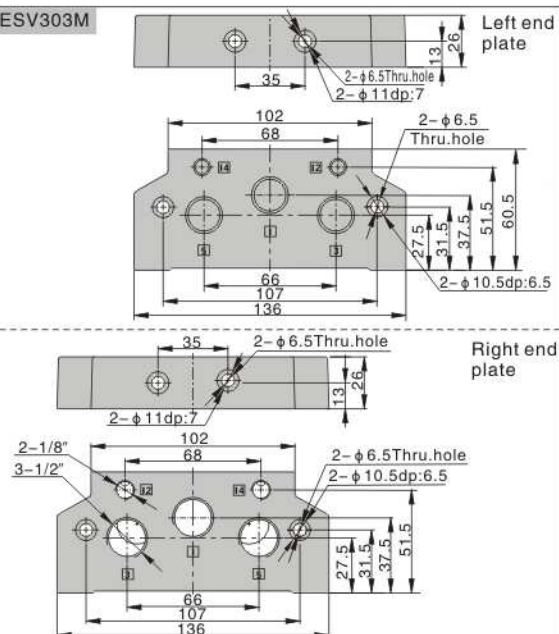

## ESV200~400 Series

### ESV310+ESV302M+ESV303M

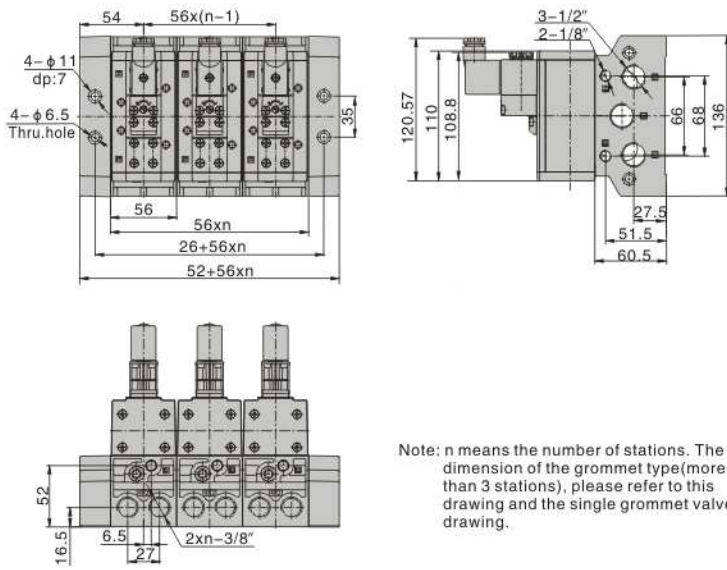

### ESV320+ESV302M+ESV303M

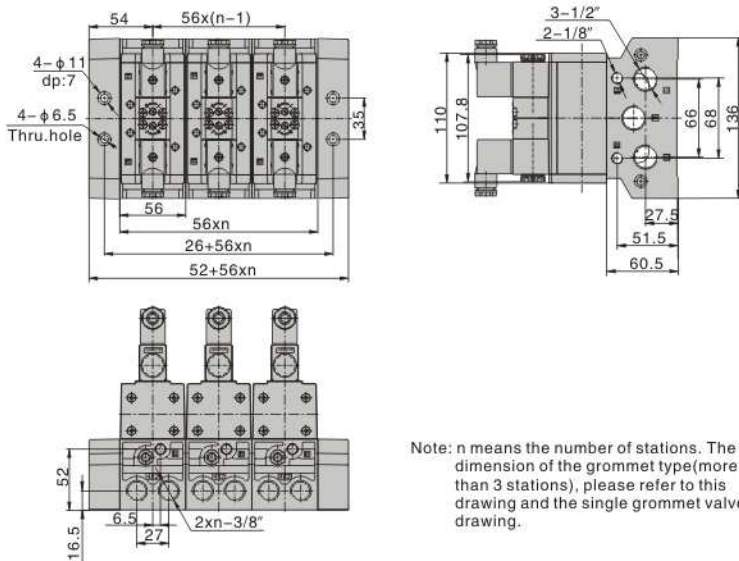

### ESV330+ESV302M+ESV303M

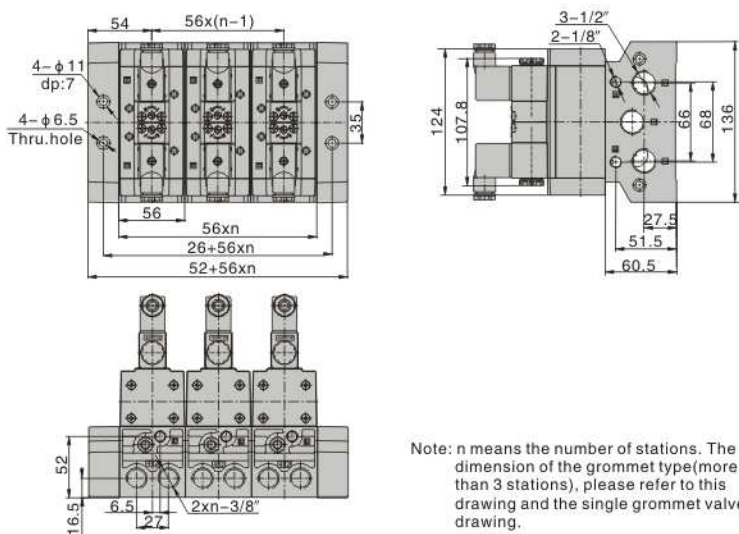

## ■ Dimensions(ESV400 Series)

### ESV410 Terminal

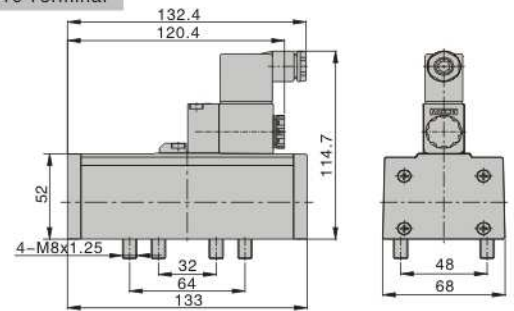

### ESV410 Grommet

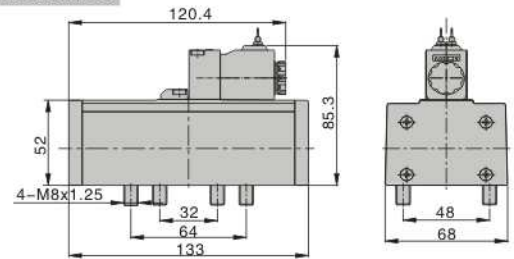

### ESV420 Terminal

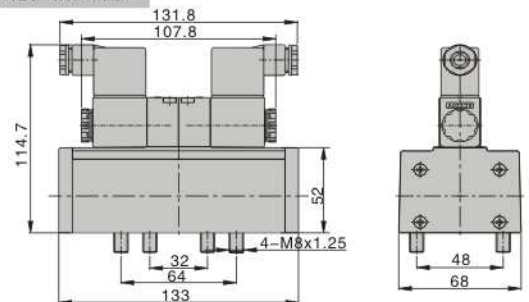

### ESV420 Grommet

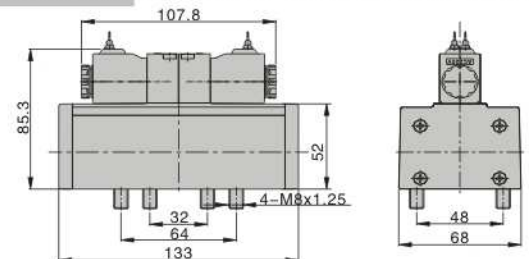

### ESV430C(EP) Terminal

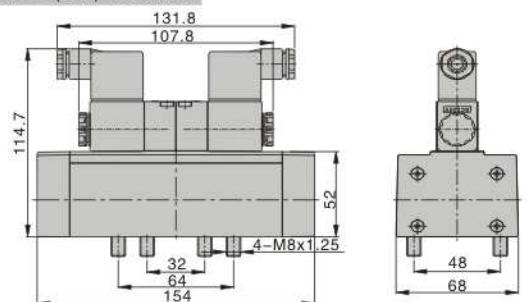

### ESV430C(EP) Grommet

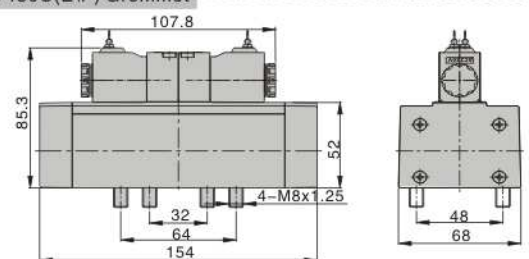



# ISO standard solenoid valve

## ESV200~400 Series

ESV401M

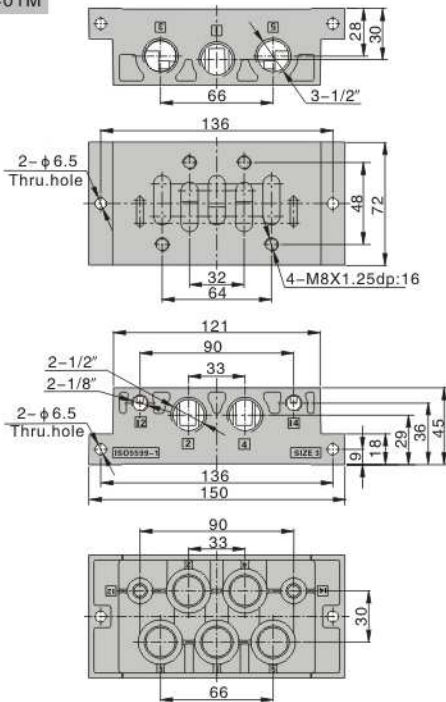

ESV410+ESV401M

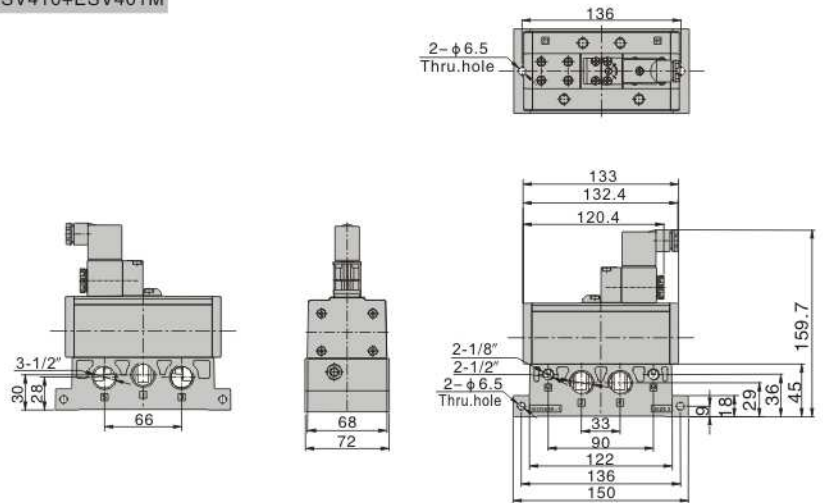

Note: This is the dimensional drawing of terminal type.  
Grommet type, please refer to the dimension of manifold and single grommet valve.

ESV420+ESV401M

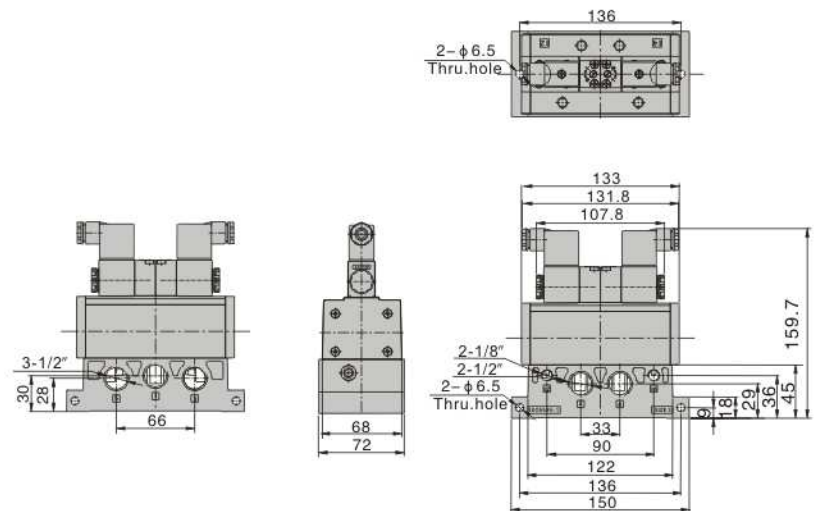

Note: This is the dimensional drawing of terminal type.  
Grommet type, please refer to the dimension of manifold and single grommet valve.

ESV402M

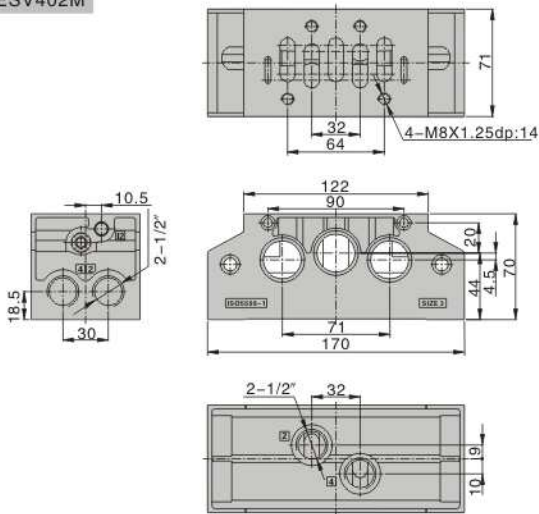

ESV403M

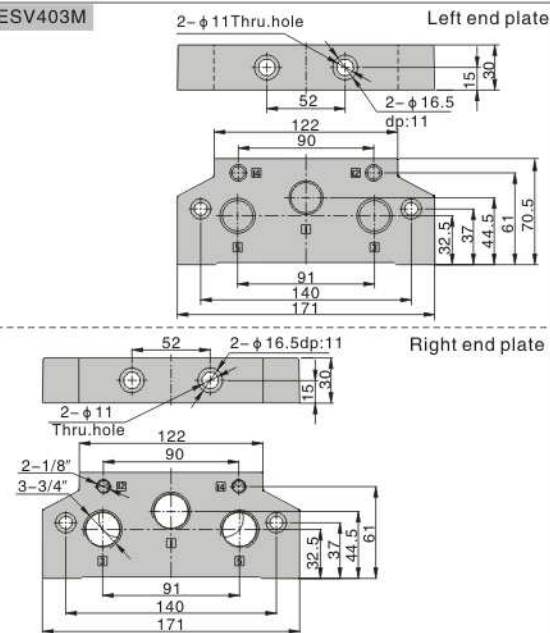

ESV430+ESV401M

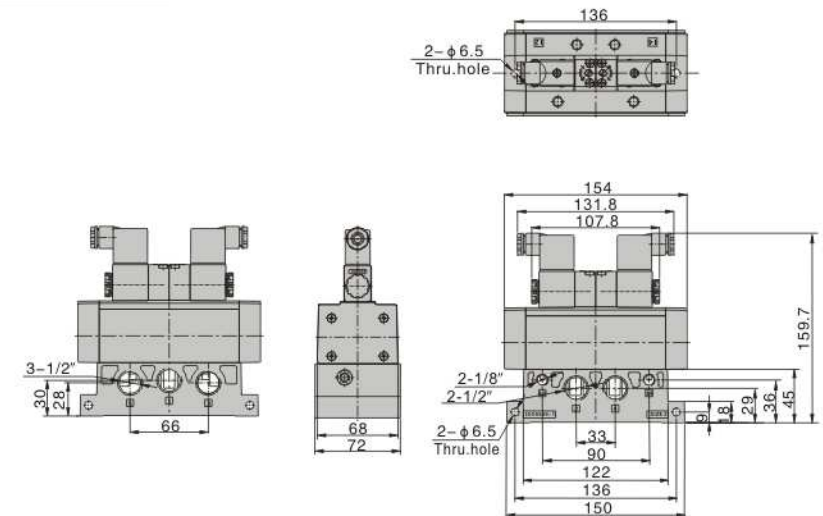

Note: This is the dimensional drawing of terminal type.  
Grommet type, please refer to the dimension of manifold and single grommet valve.

# ISO standard solenoid valve

## ESV200~400 Series

### ESV410+ESV402M+ESV403M

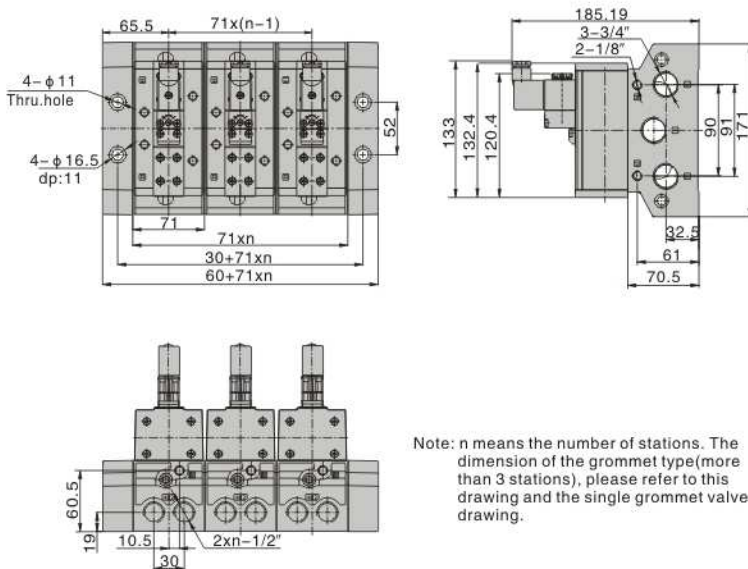

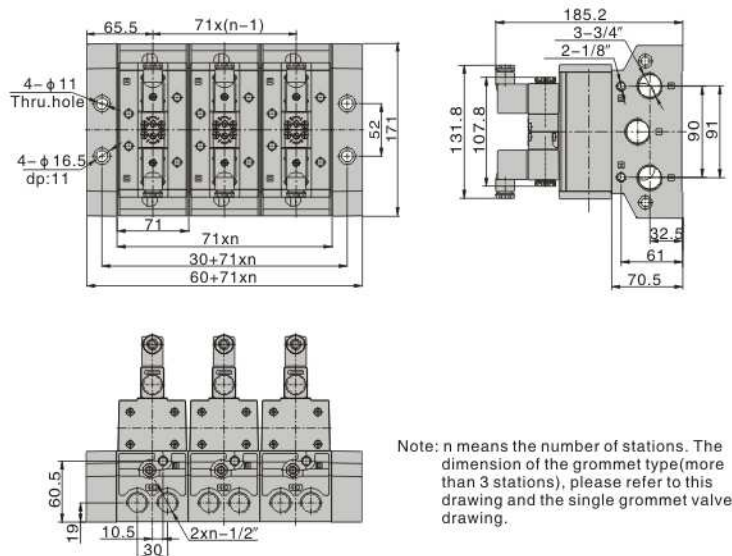

### ESV420+ESV402M+ESV403M

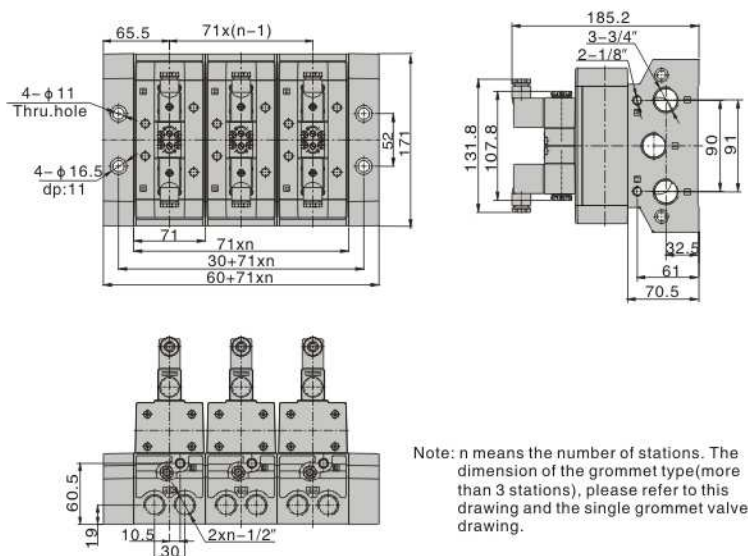

### ESV430+ESV402M+ESV403M





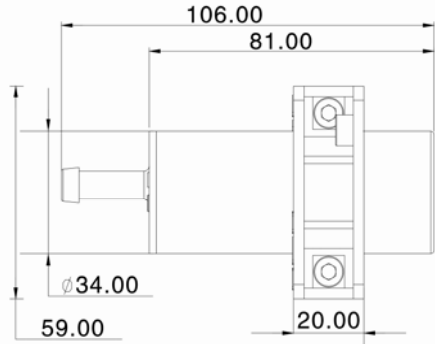
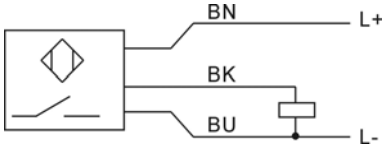

<p>IE0001 Inductive proximity sensor Plastic housing <math>\varnothing</math> 34 cable Size 80mm Sensing range 22mm[nf] Non-flush</p>	 <p>CE RoHS</p>
Electric design	DC PNP
Output	N.O. 
Operating voltage [V]	10...36 DC
Current loading [mA]	350
Short-circuit protection	Yes
Reverse polarity protection	Yes
Overload protection	Yes
Voltage drop [V]	<2.5
Consumed Current [mA]	<15(24V)
Real sensing range [mm]	22 $\pm$ 10%
Operating range [mm]	0...18
Switch-point drift [%/Sr]	-10...10
Hysteresis [%/Sr]	1...15
Switching frequency [Hz]	100
Adjustment factors	Low carbon steel=1 / Stainless steel approx. 0.7 / Brass approx. 0.5 / Alumium approx. 0.4/ Copper approx. 0.3
Operating temperature [°C]	-25°C...80°C
Protection classification	IP67
Dimension	
Housing material	PBT+GF
Switching state display LED	Red (90°)
Connection	PVC-cable /2m;3x0.34mm <sup>2</sup>
Wiring Core color  BN + BU - BK Signal Line	
Accessory(Included)	Mounting clamp

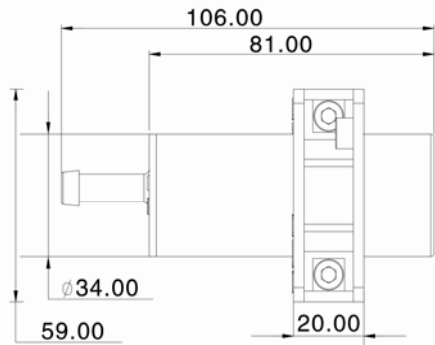
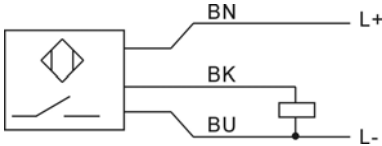

ema Electronic Corp.    Mail: [info@ema-electronic.com](mailto:info@ema-electronic.com)

<p>IE0001 Inductive proximity sensor Plastic housing <math>\varnothing</math> 34 cable Size 80mm Sensing range 22mm[nf] Non-flush</p>	 <p>CE RoHS</p>
Electric design	DC PNP
Output	N.O. 
Operating voltage [V]	10...36 DC
Current loading [mA]	350
Short-circuit protection	Yes
Reverse polarity protection	Yes
Overload protection	Yes
Voltage drop [V]	<2.5
Consumed Current [mA]	<15(24V)
Real sensing range [mm]	22 $\pm$ 10%
Operating range [mm]	0...18
Switch-point drift [%/Sr]	-10...10
Hysteresis [%/Sr]	1...15
Switching frequency [Hz]	100
Adjustment factors	Low carbon steel=1 / Stainless steel approx. 0.7 / Brass approx. 0.5 / Aluminium approx. 0.4/ Copper approx. 0.3
Operating temperature [°C]	-25°C...80°C
Protection classification	IP67
Dimension	
Housing material	PBT+GF
Switching state display LED	Red (90°)
Connection	PVC-cable /2m;3x0.34mm <sup>2</sup>
Wiring Core color  BN + BU - BK Signal Line	
Accessory(Included)	Mounting clamp



1.	Set-up.....	2
2.	General information .....	3
3.	Lubrication points .....	4
4.	Setting of parameters.....	4
5.	Standard settings .....	5
5.1	Special settings.....	5
6.	Cycle time diagram for automatic mode .....	"6
7.	Maintenance / Inspection.....	"6
8.	Installation.....	7
8.1	Installation of central lubrication system already fitted to the mixer.....	7
8.2	Filling of the pump grease reservoir.....	7
9.	Start-up.....	8
9.1	General instructions.....	8
9.2	Start-up of a central lubrication system already fitted to the mixer.....	8
9.3	Start-up of a separately supplied central lubrication system.....	8

		Bk	

## 1. Set-up

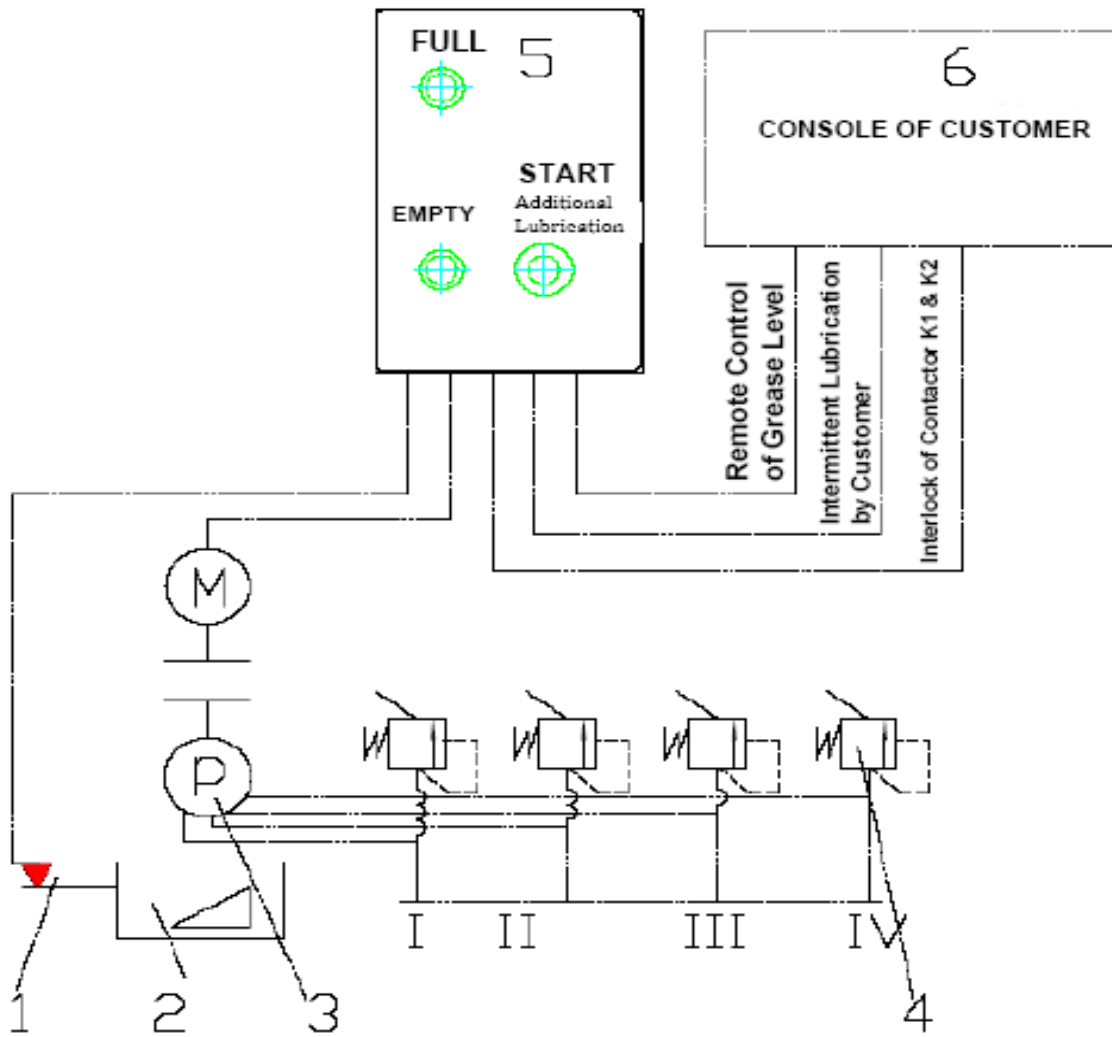

1. Grease reservoir – empty signal
2. Grease reservoir
3. Grease pump
4. Overflow valve
5. Switch cabinet (additional grease control box)
6. Client remote control console

**2. General information**

- Grease is automatically or manually delivered to 4 lubrication points by this central lubrication system.
- The plant comprises :
  - 1High-pressure central lubrication pump type 4DDB-M8
  - 4 outlets (use for 4 shaft-end sealings)
  - Control system used for additional grease
  - Various mountings, pipelines and screw connections
- The central lubrication system is controlled by the electric switch and control cabinet and must be incorporated into the overall control system (user-provided), so automatic lubrication program is active when starting the mxier.
- **The automatic lubrication control system must interlock with additional lubrication system.**

**Function at local mixer**

- Additional lubrication should be done after each shift, switchovering to additional grease option, then press the start button on the control cabinet in the mixer, the system shall re-grease to the shaft ends as per the setting time, and at the same time ensure that the main shafts of the mixer is in the state of rotation, so it may ensure the sealings to get well-proportioned and adequate lubricating, and then hand labor-saving for greasing is achieved.

**Function at remote side of customer**

- Procedure of automatic control by customer
  - When the mixer starts, meanwhile, the customer's automatic programme is activated accordingly. After expiry of the pause times set, the lubrication pump starts working and delivers the correct amount of grease predetermined by the cycle duration.
  - The grease level in the reservoir of the central lubrication pump is monitored both remotely and locally at any time . An "empty" signal on the local alarm unit is transmitted as soon as the minimum grease level has been reached, and the remote alarm system will also start.

		Bk	

### **3. *Lubrication points***

Inner sealing chambers and/or labyrinths in front of the axial face seal (4 pcs).

The function of these sealing chambers is to protect the axial face seals from the material (e.g. cement slag) penetrating the mixing chamber. It is necessary to supply grease to these compartments and/or refill the grease chambers with fresh grease via press button assembly "additional lubrication" immediately after cleaning the mixer.

### **4. *Setting of parameters***



**IMPORTANT !**

If mainly highly liquid products are mixed, we recommend to adjust the lubrication intervals at automatic operation, which means shorter pause times and/or more distributor running time.

In case the preset number of distributor valve cycles must be adjusted for the manually controlled "additional lubrication", the user may readjust the timer to set time on the control cabinet supplied with the mixer.

		<b>Bk</b>	

## 5. Standard Settings

	Mixer Size			
	Up to 0.75	1.00 – 3.00	3.50 – 4.50	4.50 – 7.00
- Lubrication interval (hours) - Lubrication duration (minutes)-	2 2	2 2.5	2 2.5	2 3
Amount of grease in cm <sup>3</sup> at operating time of 8h	256	320	320	384
Amount of grease in cm per additional lubrication	240	320	400	480
- minutes - Pump running time for additional lubrication	7.5	10	12.5	15
- Liters - Vessel volume of central lubrication pump	10*			30
- Working days - Refilling time based on 8h/day and 1 additional lubrication	ca.20	ca.15	ca.14	ca.34

\* If more grease is required, a pump with a 30L grease reservoir will be available at an additional price.



### Attention !

The pump's running time is reduced by approx. 20% for plants operated at 60 Hz, all the other parameters remain unchanged.

### 5.1 Special settings

Any special settings are indicated in the installation instructions/technical data under chapter "Setting points of the lubrication parameters".



## 6. Cycle time diagram for automatic mode

Example shown for mixer sizes from 1.00 to 4.00

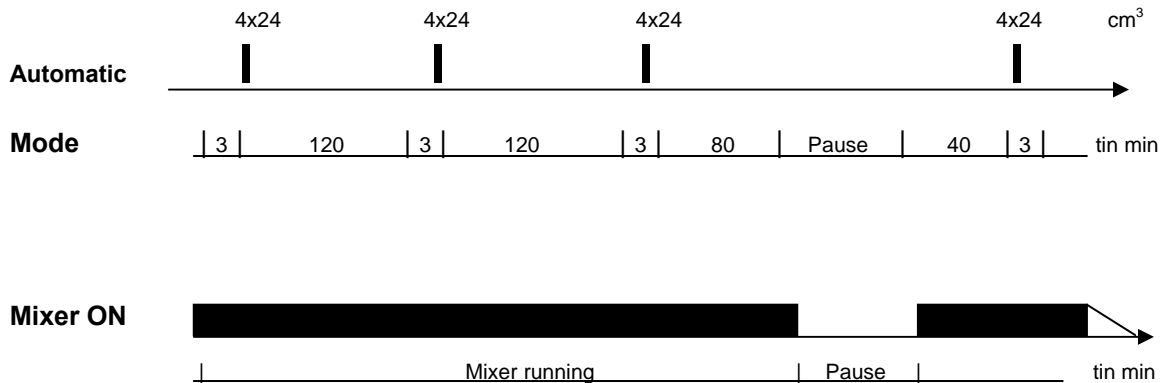

## 7. Maintenance / Inspection



### IMPORTANT !

Using a central lubrication system does not release you from making regular checks.

The interior of the mixing trough should be inspected visually once every week to verify whether grease has come out of the labyrinths arranged around the mixing shaft after completion of the additional lubrication process, which has to be started after each cleaning process.

In case of multiple shift operation or when mixing mainly liquid products, this must be repeated accordingly.

If no grease has escaped, the amount of grease for additional lubrication should be adjusted accordingly (see section 3.2).

An increased wear in the area of the labyrinths can cause – besides other reasons – an increased grease requirement.

**In case that grease overflowing is found, which means grease line is blocked, then it is necessary to dismantle the grease pipeline and clean the inside with high-pressure air and ensure to be free of the blocking.**

**If the problem is not solved yet as instruction mentioned hereinbefore, the inside of the shaft sealing retainer must be checked and cleaned, till the grease flowing is smooth.**

		Bk	

## **8. Installation**

### **8.1 Installation of central lubrication system already fitted to the mixer**

We recommend to have the installation carried out by a skilled fitter.

- Laying of the connecting cable with the specified operating voltage (see installation instructions and technical description of control unit).
- Connecting remote control (interrupted oil supply, oil level control, interlock) to the switch cabinet.
- If the cabinet of the central lubrication system is not directly fitted to the mixer, you must lay the connection cables for pump motor, empty signal – grease reservoir from the terminal box at the mixer to the control cabinet and to the proximity switch of the progressive distributor.
- We recommend to install the following signals and/or switches in the control room of the entire plant.
  - Signal lamp for „Fault“
  - Signal lamp for „Reservoir empty“
  - Signal lamp for „Pump ON“

### **8.2 Filling of the pump grease reservoir**

- Grease should be filled into the pump reservoir through nipples to avoid impurities.
- Since empty/full level is controlled by position sensor, make sure that there is no grease on the vessel lid in the area of the position sensor when you fill the pump reservoir in order to ensure the function of the indications.
- In order to be able to recognize the maximum grease level when the reservoir lid is closed, the full level signal is installed in a red indicator light at the terminal box close to the grease lubrication pump to be able to stop the grease replenishing system in a timely manner.
- In case of a permanently incorporated automatic grease replenishing system the filling action can be automated.

		Bk	

## **9. Start-up**

### **9.1 General Instructions**



We recommend to have the start-up carried out by a skilled fitter.

#### **ATTENTION!**

Prior to start-up carefully read and observe the General Safety Instructions for Machines and plants as well as the particular safety instructions for the grease lubrication pump and the progressive distributor.

### **9.2 Start-up of a central lubrication system already fitted to the mixer**



The plant will be ready for operation after electrical installation.

#### **ATTENTION!**

- Check sense of rotation of the pump motor  
See arrow at pump reservoir
- Compare the data set on the display of the switch and control cabinet with the data of the standard setting chart (see item 5.) and /or recommended setting parameters (see installation instructions).

### **9.3 Start-up of a separately supplied central lubrication system**

We recommend to have the start-up carried out by a skilled fitter.

#### **ATTENTION!**

- Check sense of rotation of the pump motor  
See arrow at pump reservoir
- Start manual lubrication by actuating the button "additional lubrication". According to the number of distributor valve cycles set, grease is supplied to the 4 lubrication points. This procedure has to be repeated until grease escapes in the interior mixer chamber around the mixing shafts.
- Refill grease reservoir (see item 5.)
- Compare data set on the display of the switch and control cabinet with the data of the standard setting chart (see item 5.) and/or recommended setting parameters (see Installation instructions)
- Release operation control key for automatic operation.

		<b>Bk</b>	

	<b>Technical Documents</b>		<b>600136205-001 A</b>	
	<b>DDB GREASE PUMP SYSTEM 4DDB-M8</b>		版本	<b>05/10</b>
			页码	<b>1 - 10</b>

## 4DDB-M8

### 1. Application and characteristics

4DDB-M8 is a grease plunger pump with high pressure and multiple lines. This pump has 8 removable output ports at most. Each output port inside the pump is assigned a delivery piston of its own that simultaneously meters the lubricant (adjustable). Each output port has independent pressure protection. Equipped with high grease level & low grease level indicator, 4DDB-M8 leads directly from the pump to the lubrication points or to a progressive feeder that further divides up the respective delivery rates of the connected outlet ports. It's easy to use and maintain. 4DDB-M8 is applicable for the centralized lubricating systems in all types of heavy machines.

### 2. Specification and technical parameter

Item Type	Nominal discharge mL /time	Nominal pressure MPa	Stroke frequency Cy/min	Number of pump units	Grease (NLGI)	Reservoir capacity	Outer diameter of output pipe	Motor power kw
4DDB-M8/10	0.27	28	30	1~8	000~ 2#	10L	Φ8	0.37

Note: 1. 1~8 pump units can be selected upon making order.

2. High grease level & low grease level indicator: normal open contact, AC 220V/1A  
DC24V/2A.

### 3. Dimension drawing (drawing 1)D1

--	--	--	--

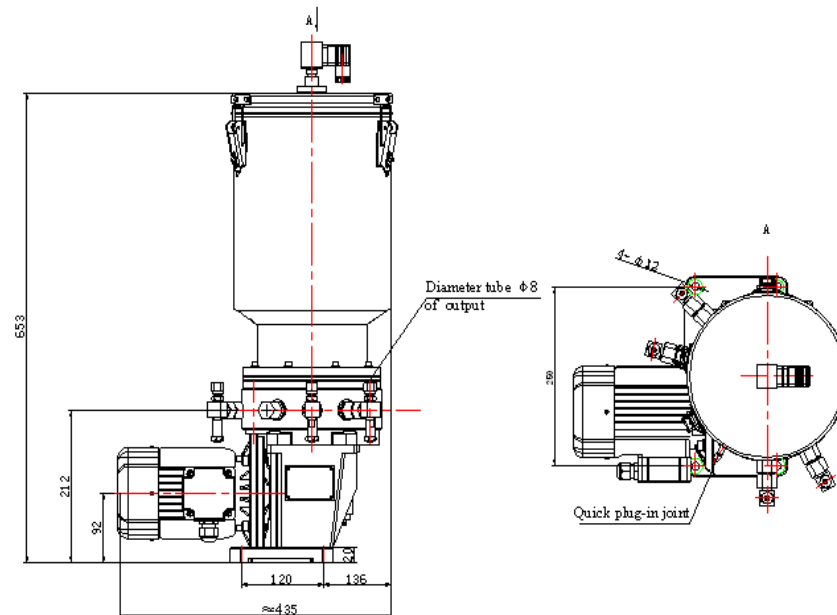

Drawing 1

#### 4. Structure and working principle

4DDB-M8 is a plunger pump (D2, drawing 2). The motor directly connects reducer (1) to make eccentric shaft (2) rotate. The driven plate (3) on eccentric shaft to force the plunger of each pump unit (4) to move back and forth alternately, in turn to complete the suction and discharge process. When the plunger discharges grease, the slide valve (5) is opened, then the grease is charged from the hole of slide valve.

Each pump unit is equipped with safety valve (8) and check valve (6) independently to avoid overload and pressure interference during the operation. Toroid (11) on squeezing plate (14) triggers magnetic switch (12) in center pole (10) to indicate the high level or low level of the grease.

--	--	--	--

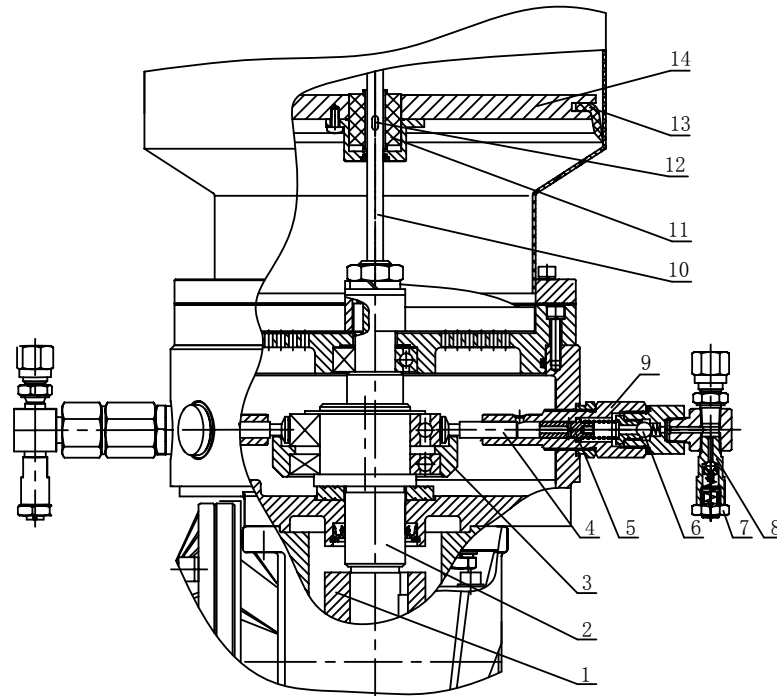

1 Reducer 2 Eccentric shaft 3 Driven plate 4 The plunger  
5 Slide valve 6 Check valve 7 Locknut 8 Safety valve  
9 Pump unit body 10 Center pole 11 Toroid 12 Magnetic switch  
13 L seal ring 14 Squeezing plate

Drawing 2

## 5. Cautions on installation

- 5.1 The pump should be installed in the location where there is little pollution, easy-wiring, convenient to connect with pipe and fill grease.
- 5.2 Grease (NLGI 000~2) should be used for the pump.
- 5.3 The applicable voltage is AC 380V $\pm$ 10%. Motor with voltage of 80V~480V is available according to customer's demand. Grease level indicator should be connected with the protection circuit. **While wiring, the correct rotation direction of the motor should be guaranteed.**

	<b>Technical Documents</b>		<b>600136205-001 A</b>	
	<b>DDB GREASE PUMP SYSTEM 4DDB-M8</b>		版本	<b>05/10</b>
			页码	<b>4 - 10</b>

5.4 When the pump runs for the first time or it starts to run after long-term closing down, the old grease in reservoir should be cleaned out and new grease should be filled.

5.5 Grease should be filled from the special input port. Grease should be clean, without any impurity or air bubble. Grease level indicators to be installed in the reservoir. Input port is equipped with quick plug-in joint if SJB-10ZA grease pump with manual feeding is used. Adapter has to be used to feed grease if the other pumps are selected. Rubber cap should be covered the quick plug-in joint after the grease filling is finished.

5.6 Inner holes of all pipes in lubricating system have to be cleaned. Pipe joints should be used as few as possible and lubricating pipe should be bent as little as possible. Lubricating pipes should be fixed by clamp.

## **6. Use and maintenance**

6.1 Before the pipes/tubes are connected with the lubrication pump, the pump should run in for 5 minutes to ensure the normal operation of the pump.

6.2 Each pump unit has safety valve. The protection pressure of 4DDB-M8 has been set to 28Mpa. When user adjusts the pressure of safety valve, pressure gauge has to be installed on the pipe. Generally, user is not allowed to adjust the pressure of safety valve.

6.3 Each pump unit has check valve to avoid the pressure interference during the operation and grease circumfluence.

6.4 Joint of output is complied with G8 GB3733.1 (Drawing 3). Cold rolling seamless

--	--	--	--

tubes or high-pressure pipes should be used. Before the tube is connected, burr in the inner and outer side of tube (3) should be broken and the edges should be sharpened. Loosen nut (2) and slowly insert the tube into sleeve. The tube should protrude 3~5mm from sleeve. Tighten the nut.

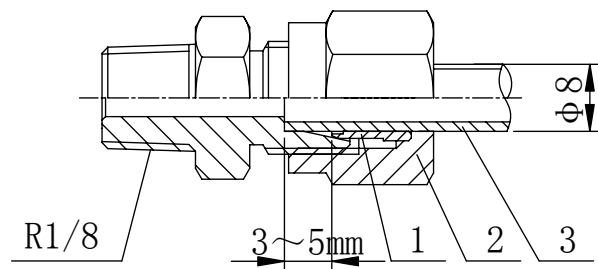

D3

6.5 Before the pipes/tubes are connected with the lubrication pump, the pump should run in for 5 minutes to ensure the normal operation of the pump.

**Grease should be filled into all lubricating points and distributors to ensure the smooth flow. If necessary, all of the pipes/tubes should be filled with grease before connection.**

6.6 Each output port can be used in parallel in order to meet the demand of lubrication point. In order to increase the number of lubrication points, all types of progressive distributors manufactured by our company can be selected and used.

When progressive distributor is used with the pump, pipes/tubes at the output port of the progressive distributor should have the similar length. **It's not allowed to arbitrarily jam output port of the progressive distributor.**

--	--	--	--



	<b>Technical Documents</b>		<b>600136205-001 A</b>	
	<b>DDB GREASE PUMP SYSTEM 4DDB-M8</b>		版本	<b>05/10</b>
			页码	<b>6 - 10</b>

## 7. Troubleshooting and maintenance

### 7.1 Troubleshooting

Trouble	Reason	Solution
Pump Pump cannot discharge grease	Empty reservoir	Fill grease and release air from pump
	Motor rotates in wrong direction	Connect wire again and confirm the correct direction
	Contaminant Inside of safety valve	Clean safety valve and set pressure again
	Block in check valve or damaged check valve	Clean or replace core of check valve
	Block in suction port or output port of pump unit	Disassemble pump unit and clean
	Wear of pump unit	Replace pump unit
No pressure	Pipe/tube leakage	Check whether leakage occurs at each pipe/tubejoint
	Contaminant Inside of safety valve	Clean safety valve and set pressure again
	Wear of pump unit	Replace pump unit
Block in main pump or system	Block in lubrication point, pipe/tube and distributor. Overflow of grease from safety valve Cycle indicator at distributor does not work	Check whether lubrication point is blocked. Clean out if necessary. Check whether pipe/tube or distributor is blocked. Clean out if necessary. Check whether the plunger of distributor is blocked. Clean if necessary. Check whether the output port of distributor is jammed. Clean out if necessary.

7.2 Pump unit at each output port is removable. The maintenance should be carried out by following these steps:

--	--	--	--

a) Loosen pump body (9), push motor to enable shaft to rotate to the lock point outside of plunger. (drawing 4).

b) Slowly turn the pump body (9) from  
The system. **Caution: don't use punner to disassemble.**

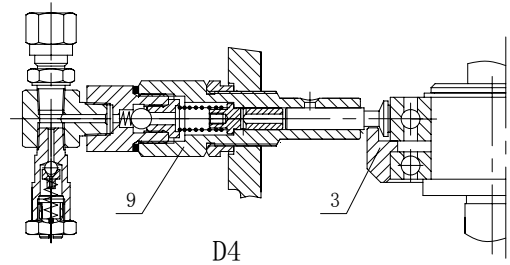

c) Slightly draw the pump body (9) and plunger (4) out from the installation hole (drawing 5) in the inclined downward direction by following the direction of disassembly.

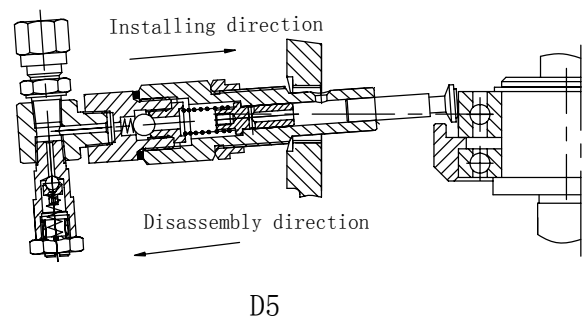

**Caution: Plunger is not allowed to fall off in the cavity of pump.**

d) Turn shaft about 30° in turn and remove the adjacent pump units by following the above steps.

**7.3 Caution: Each plunger, sliding valve and pump body have to be used together. They cannot be exchange.**

7.4 Assemble each pump unit by following these steps:

a) Cleaning up grease from the installation hole to the driven plate (D5.1).

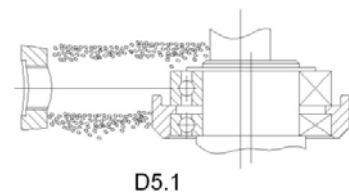

D5.1

Remove the mask of motor fan (Ensure that the power have been shut off),  
Push the fan of motor by hand (D5.2).

b) Push motor to enable shaft to rotate to the lock point  
outside of plunger.  $B=57.5\text{mm}$ (drawing 6).

c) Draw the plunger from the pump unit  
 $C=30\text{mm}$ (drawing 7).

d) Insert the pump body and plunger into the  
installation hole in the inclined upward  
direction by following the direction of  
assembly shown in drawing 5.

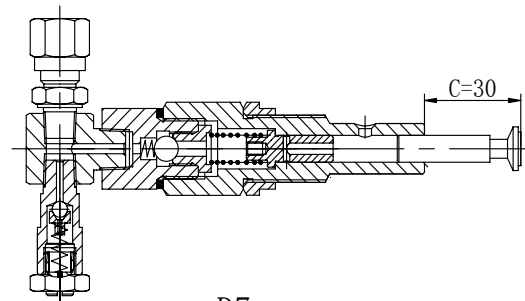

D7

Connect plunger and driven plate as shown in drawing 4.(D4)

**Caution: do not install the end of plunger outside of driven plate. (drawing 8)**

e) Turn shaft about 30° in turn and install each pump unit by following the above steps.

f) After the assembly is completed, push motor to enable shaft to rotate. The rotation should be smooth, without stagnation.

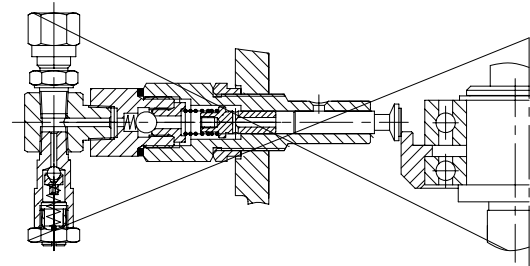

D8

g) After power is on, inch the motor for several times. 30 seconds per time. Confirm normal operation.

#### 8. Wearing part (drawing 9)

1. Motor
2. Reducer
3. Pump unit
4. Safety valve
5. Toroid
6. Center pole (2 magnetic switches are inside)

(Note: Grease level indicator is composed of toroid and center pole)

--	--	--	--

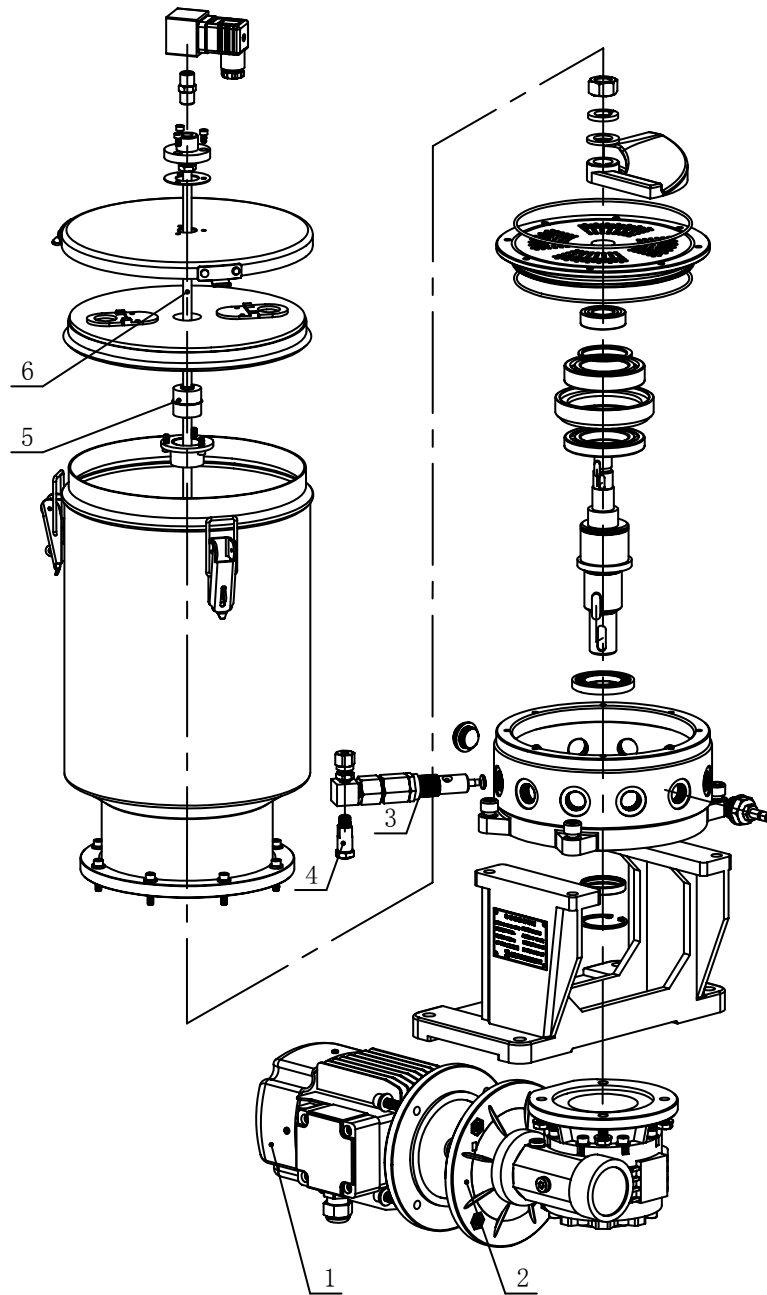

D9

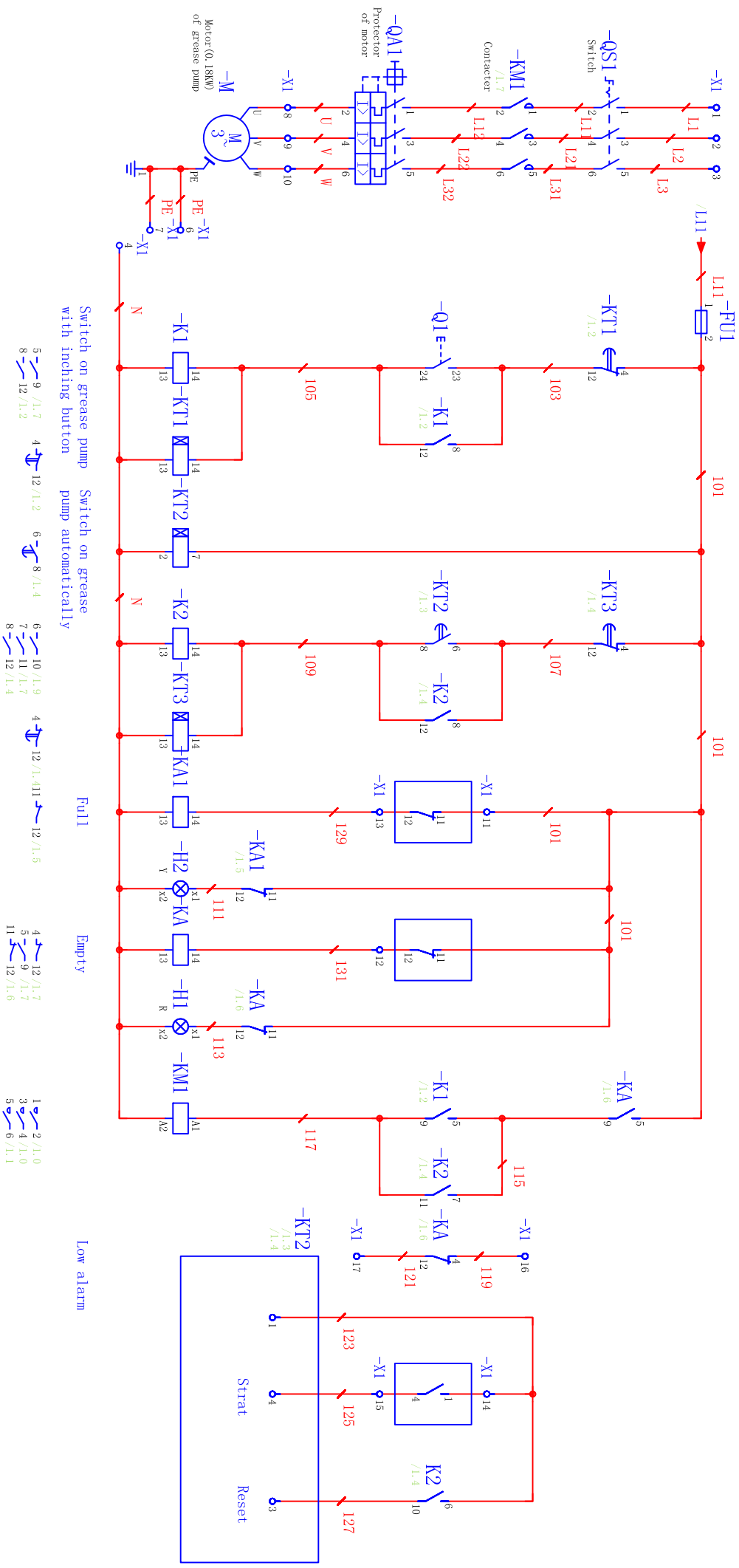

control



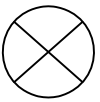

Empty  
red HI

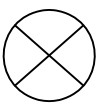

Full  
yellow H2

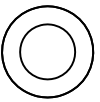

Strat



Open/Close



control



## 1 General Introduction

HHS6 series intelligent digital timer (hereinafter referred to as relay) is used as time delay component to make or break circuit according to preset time for control circuit with operating voltage of AC 50Hz, 380V and below or DC operating voltage of 24V.

This series relay executes Q/ZXL 0081 enterprise standard and complies with relevant requirement of GB 14048.5 and JB/T 10047.

## 2 Main Technical Data

Table

Model	HHS6A	HHS6G	HHS6A-1	HHS6G-1	HHS6A-2	HHS6G-2	HHS6A-3	HHS6G-3
Working Voltage	AC380V, AC220V, AC110V, AC36V, AC24V 50Hz; DC24V, allowable voltage fluctuation range (85%~110%)Ue							
Delay Range	0.01s~99.99s, 1s~99m99s, 1m~99h99m settable							
Repeated Error	if delay range is more than 1s, $Er \leq 1\%$ ; if delay range is less than 1s, $Dr \leq 50ms$							
Working Mode	on-delay	release delay	on-delay	release delay	on-delay	release delay	on-delay	release delay
Contact Quantity	2 groups delay contact switchover (with reset and start function)		1 group delay contact switchover (with reset and start function)		2 groups delay contact switchover		2 groups delay contact switchover (with reset and start function)	
Contact Quantity	3A AC250V(resistance)							
Electrical Life	1*10 <sup>5</sup>							

①

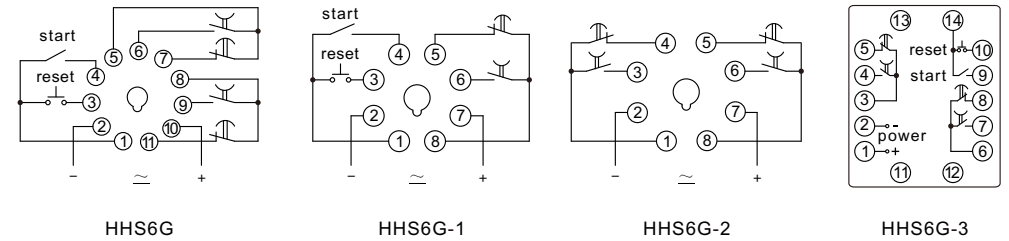

## 4 Outline and Mounting Dimension(mm)

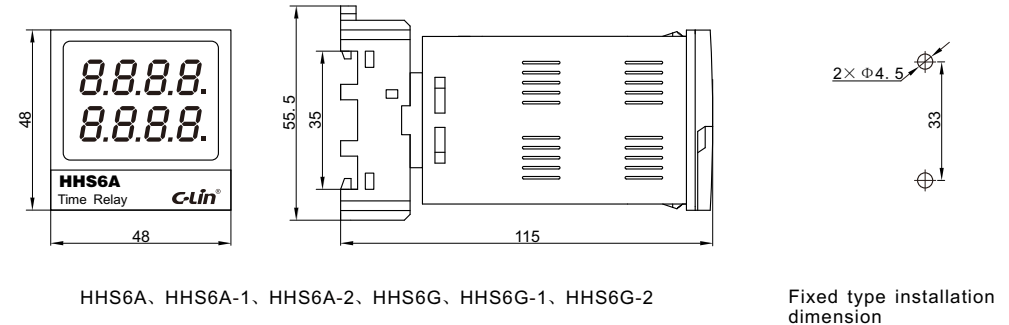

③

Table(extend)

Model	HHS6A	HHS6G	HHS6A-1	HHS6G-1	HHS6A-2	HHS6G-2	HHS6A-3	HHS6G-3
Ambient Temperature	minus 5°C~40°C							
Altitude	below 2000m							
Humidity	when the maximum temperature is 40°C, the maximum relative humidity should be less than 50%. Lower temperature allows higher relative humidity. For example, when it is 20°C, the relative humidity can be 90%. Special measures should be taken for condensation due to temperature change.							
Installation Mode	panel type, guide rail, fixed type							

## 3 Wiring Diagram

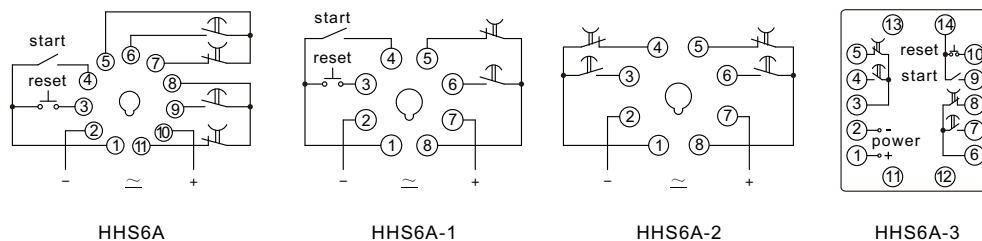

②

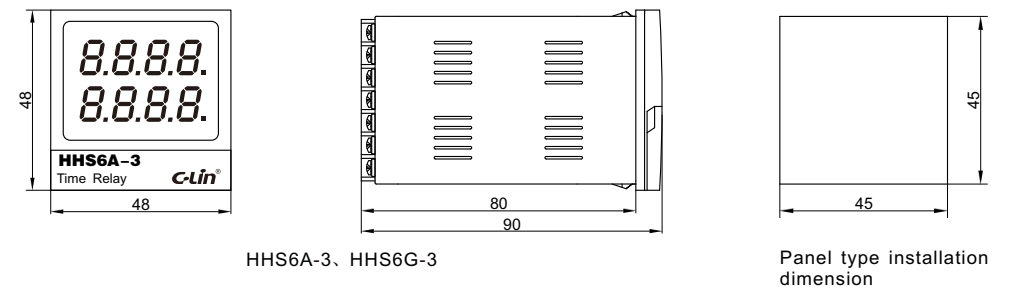

④

## 5 Panel Instruction

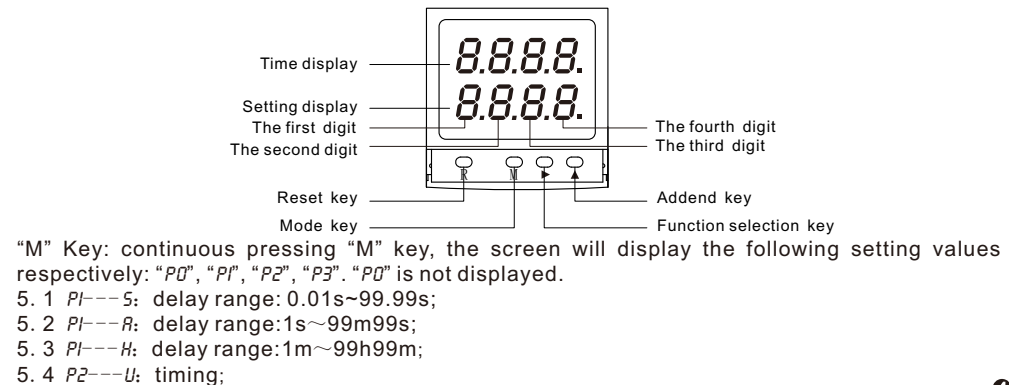

④

- 5. 5 P2---d: countdown;
- 5. 6 P3---E: display value starting up automatic reset;
- 5. 7 P3---F: display value power off memory keep.

“▶” Key:

5. 1 Selection function: during time parameter setting, press this key to choose the parameter which need adjusting.

5. 2 Pause function: when timing, press this key to pause. Press again, it will continue to cumulate time.

“▲” Key: press this key to add the number on the selected item to achieve incremental change.

“R” Key:

5. 1 Reset function: press this key to reset the displayed timing number and timing output state to the initial state.

5. 2 Confirmation function: after time parameter is set, press this key to confirm.

### 6 Use Instructions

In time parameter settings, users can set as required, because the product has a memory function. The displayed parameter after power on is the last set parameter. Take the setting time value 12m34s, countdown, power off memory and last set parameter 00.00 as an example.

6. 1 According to the wiring diagram label in the relay and refer to.Circuit Application to connect the product.

6. 2 Press “▶”key before setting parameter. Pause timing, and set the parameter by the following time parameter setting. After finishing setting, press “▶” to continue to time.

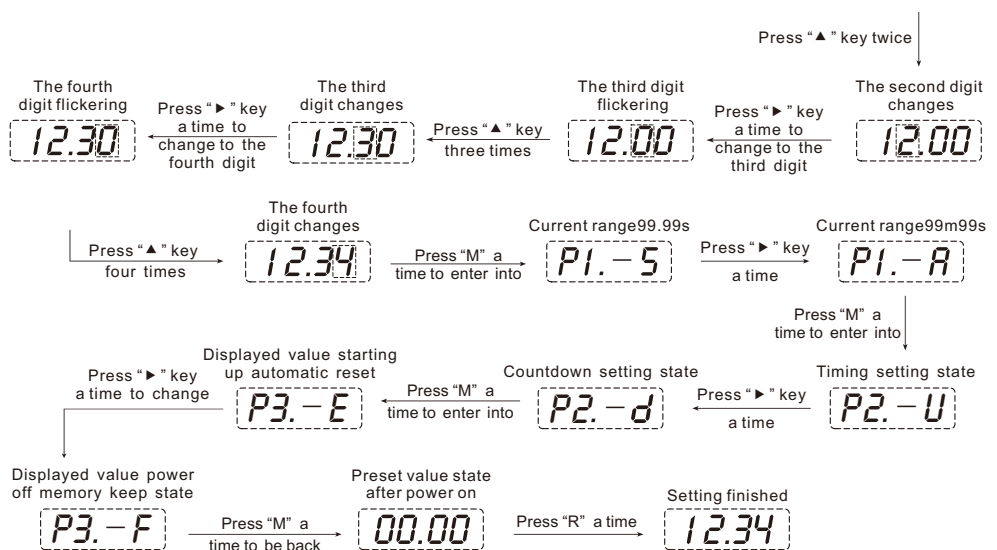
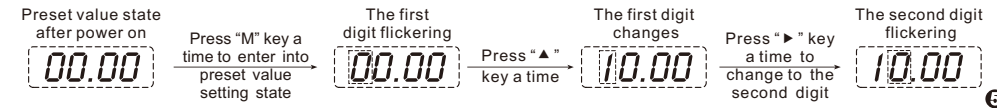

### 7 Precautions

7. 1 When changing the setting parameters in any state, users must press “R”key or short connect terminals 1, 3for HHS6A/G,HHS6A/G-1 or short connect terminals 14,10 for HHS6A/G-3 and reset to restart to set the parameters to time.

7. 2 Reset function: in any time press “R” key or short connect terminals 1,3 for HHS6A/G,

HHS6A/G-1 or terminals 14,10 for HHS6A/G-3 and reset; relay is back to the initial state. Re-timing after disconnecting.

7. 3 Start Function: connect HHS6A/G,HHG6A/G-1 terminals 1, 4 or HHS6A/G-3 terminals 14, 9 to start time. When disconnecting, it stops timing and keeps the numbers at the moment; after power on, it cumulate to time again.

7. 4 Interval time of relay power-on and power-off shall be equal to or more than 0.5s.

7. 5 Under the strong electric field environment, the “reset” and “start” connectors are too long, use the shielded wire and do not input voltage to “reset” and “start” terminals for fear of damaging the product.

### 8 Circuit Application(take HHS6A-2 as an example)

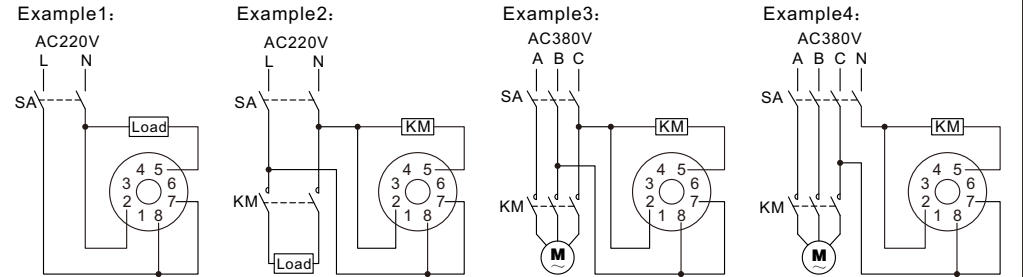

8. 1 As for single load, if load resistive current is  $\leq 3A$  or induced current is  $\leq 0.5A$ , the relay directly controls, refer to example 1 for wiring; if load resistive current is  $> 3A$  or induced current is  $> 0.5A$ , the relay expands through AC contactor, refer to example 2 for wiring; as for three phase load, when AC contactor and relay power supply is AC380V, refer to example 3 for wiring; when AC contactor and relay power supply is AC220V, refer to example 4 for wiring.

8. 2 Function of relay as shown in example: when switching on power, load or KM(AC contactor) is powered on. After preset delay time is up, the load or KM(AC contactor) is powered off.

**Note 1:** the load can be load lamp or lamp bulb, which can directly be connected to two wires at the terminal of load lamp or lamp bulb. (shown as example 1).

**Note 2:** KM denotes coil of AC contactor, terminals A1, A2 can be connected according to example 2, 3, 4.

**Note 3:** the operating power supply of both time relay and KM in example 3 is AC380V. Pay attention to voltage rating.

### 9 Notes for Placing Order

The customer shall specify model, voltage rating and quantity of product, and any special requirement shall be remarked.

E.g.: HHS6A-2 AC220V 100 pcs.

Zhejiang Famous Trademark National Hi-tech Enterprise

Operation Instruction

**HHS6 esies**  
Intelligent Digital Timer

Thank you for using CLIN protective device, please carefully read the operation instruction!

Xinling Electrical Co., Ltd.  
Add: Zhiguang Industrial Zone, Lishui, Yueqing City, Zhejiang Province P.R.China 325604  
Tel: 86-577-62735555 Fax: 86-577-62722963  
Technical support: 86-577-62731208 www.xinling.com

## Metal bodied limit switch Series D

Description **D-A2Z RW**

Article number **6041818741**

### Operating symbol

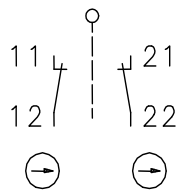

### Operating diagram

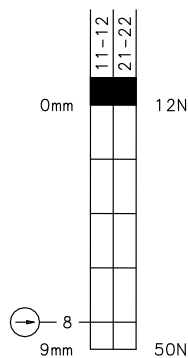

On
  Off

Tolerance:  
Operating Point  $\pm 0,25$  mm;  
Actuating force:  $\pm 10$  %

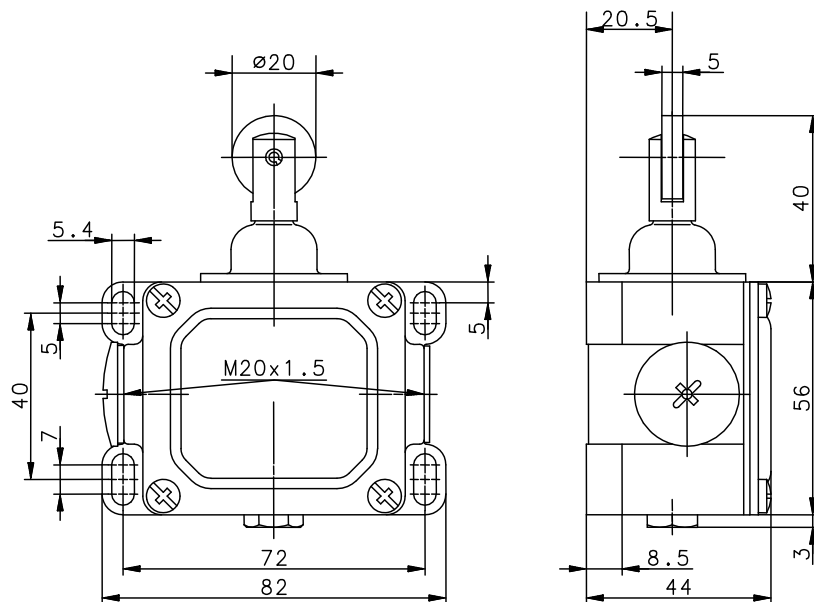

### Electrical Data

Rated insulation voltage	$U_i$	400 V AC
Conv. thermal current	$I_{the}$	16 A
Rated operational voltage	$U_e$	240 V
Utilization category		AC-15, $U_e/I_e$ 240 V / 10 A
Direct opening action	$\ominus$	acc. to IEC/EN 60947-5-1, Annex K
Short-circuit protective device		Fuse 16 A gG
Protection class		I

Mechanical data	
Enclosure	Die-cast aluminium
Cover	Sheet aluminium
Actuator	Push bolt with roller(steel)
Ambient air temperature	-30 °C ... +80 °C
Contact type	2 NC (Zb)
Mechanical life	10 x 10 <sup>6</sup> switching cycles
Switching frequency	≤ 100 / min.
Assembly	4 x M5
Connection	4 screw connections (M4)
Conductor cross-sections	Solid: 0,5 ... 1,5 mm <sup>2</sup> or Litz wire with ferrules: 0,5 ... 1,5 mm <sup>2</sup>
Cable entrance	2 x M20 x 1,5
Weight	≈ 0,29 kg
Installation position	operator definable
Protection type	IP65 acc. to IEC/EN 60529

ID for safety engineering	
B10d	20 x 10 <sup>6</sup> cycles

Actuation	
By loosening the 4 screws the actuation assembly can be rotated in 90 degree increments such that 4 actuation directions are possible. The actuation assembly is to be again fastened to the housing using the 4 screws.	

Standards	
	VDE 0660 T100, DIN EN 60947-1, IEC 60947-1
	VDE 0660 T200, DIN EN 60947-5-1, IEC 60947-5-1
	DIN EN ISO 13849-1

EU Conformity	
	acc. to directive 2006/95/EC

Approvals	
	c_CSA <sub>US</sub> A300 (same polarity)
	CCC

Notes	
The degree of protection (IP code) specified applies solely to a property closed cover and the use of an equivalent cable gland with adequate cable.	

Pos	QTY	Part #	ARTICLE SHORT DESCRIPTION 1	ARTICLE SHORT DESCRIPTION 2	DIM/TYPE	MATERIAL	STANDARD	WEIGHT
1	1	900382800	NOTICE		MASCHINEN/ANLA			0,00
2	1	902026359	TROUGH WEARING PARTS					
3	1	900553500	DISCHARGE ROTARY GATE					
4	1	902022614	DISCHARGE DOOR OPERATION PNEU.	SPARE PARTS DRAWING				
5	1	902015131	MIXING SHAFT WITH BEARING					
6	1	902007436	MIXING TOOLS					
7	1	902021452	DRIVE WITHOUT TURBO					
8	1	902023596	LUBRICATION PIPE AS	SPARE PARTS DRAWING				
9	1	902023597	LUBRICATION PIPE AGS	SPARE PARTS DRAWING				
10	1	902029087	CENTRAL LUBRICATION GREASE					
11	1	902025609	SPLASH GUARD	SPARE PARTS DRAWING				
12	1	902020848	TROUGH COVER	SPARE PARTS DRAWING				
			<b>END OF BOM!</b>					

<b>SPARE PARTS LIST</b>	DKXS1,25	SPARE PARTS LIST	
	902030247		

**Condition for continuous function and readiness for use of the machine/plant is that the most important spare and wearing parts are kept on stock.**

**Our guarantee covers only original spare parts, which have been supplied by us.**

With your spare parts order please indicate the following:

		see:
<b>Werk no.</b>		spare parts list, nameplate, client's documentation cover sheet
<b>Year of construction</b>		nameplate, client's documentation cover sheet

No. of spare parts (f. e. 9X XXXXX)	item	part no.	required quantity	denomination

By ordering hoses, seals and similar materials please specify the required length.  
Deviations from the above indication make the treatment of your order difficult and can lead to wrong deliveries.

**Dept.: Spare Parts / After-Sales Service**



**BHS-Sonthofen GmbH**



**Mixing, Crushing and Recycling Division**

Mr. Gerd Maurer +49 8321 6099 - 144  
Mr. Claudio Sileo +49 8321 6099 - 145  
Mr. Stefan Zink +49 8321 6099 - 146  
Fax +49 8321 6099 - 220

Postfach 1164  
87515 Sonthofen

An der Eisenschmelze 47  
87527 Sonthofen

**Filtration Division**

Mr. Jürgen Maurer +49 8321 6099 - 342  
Mr. Manuel Stöhr +49 8321 6099 - 347  
Mrs. Ursula Schaidnager +49 8321 6099 - 344  
Fax +49 8321 6099 - 220

					<b>Notices for List of Spare Parts</b>	
Stand	Datum	Name	Bemerkung	900382800-00E J		

Pos	QTY	Part #	ARTICLE SHORT DESCRIPTION 1	ARTICLE SHORT DESCRIPTION 2	DIM/TYPE	MATERIAL	STANDARD	WEIGHT
1	2	200005602	FIXING ANGLE			S235JRG2		19,30
2	8	100202700	FRONT WALL HARD CAST LINER			W4 D		15,50
3	4	100202800	FRONT WALL HARD CAST LINER			W4 D		15,50
4	4	100223300	FRONT WALL HARD CAST LINER			W4 D		15,50
5	4	100203000	FRONT WALL HARD CAST LINER			W4D		6,00
6	2	100202900	FRONT WALL HARD CAST LINER			W4 D		8,00
7	12	100455500	TROUGH TILE EXTERNAL			W3		8,00
8	18	100455400	TROUGH TILE INTERNAL			W3		9,00
9	6	100608700	TROUGH SHEET UPPER PART			UST		15,40
10	4	200006451	TROUGH SHEET UPPER PART					15,20
11	4	200005507	DISCHARGE DOOR LEDGE			W4D		9,90
12	2	200005517	DISCHARGE DOOR COVER			W4D		14,60
14	104	100240700	COUNTERSUNK SCREW			8.8 galv.vz.		0,10
15	12	101148800	COUNTERSUNK SCREW			8.8/W4D		0,15
17	116	503041600	HEXAGON NUT		M16	8, VERZ.	DIN 934	0,04
18	116	503351600	DISK		17	ST VZ.-140	DIN 125	0,01
19	12	503361600	SPRING RING		A 16-VSK	FST/DACROM	DIN 128*	0,01
			<b>END OF BOM!</b>					

## SPARE PARTS LIST

DKX 1,25

TROUGH WEARING PARTS

902026359

SPARE PARTS DRAWING



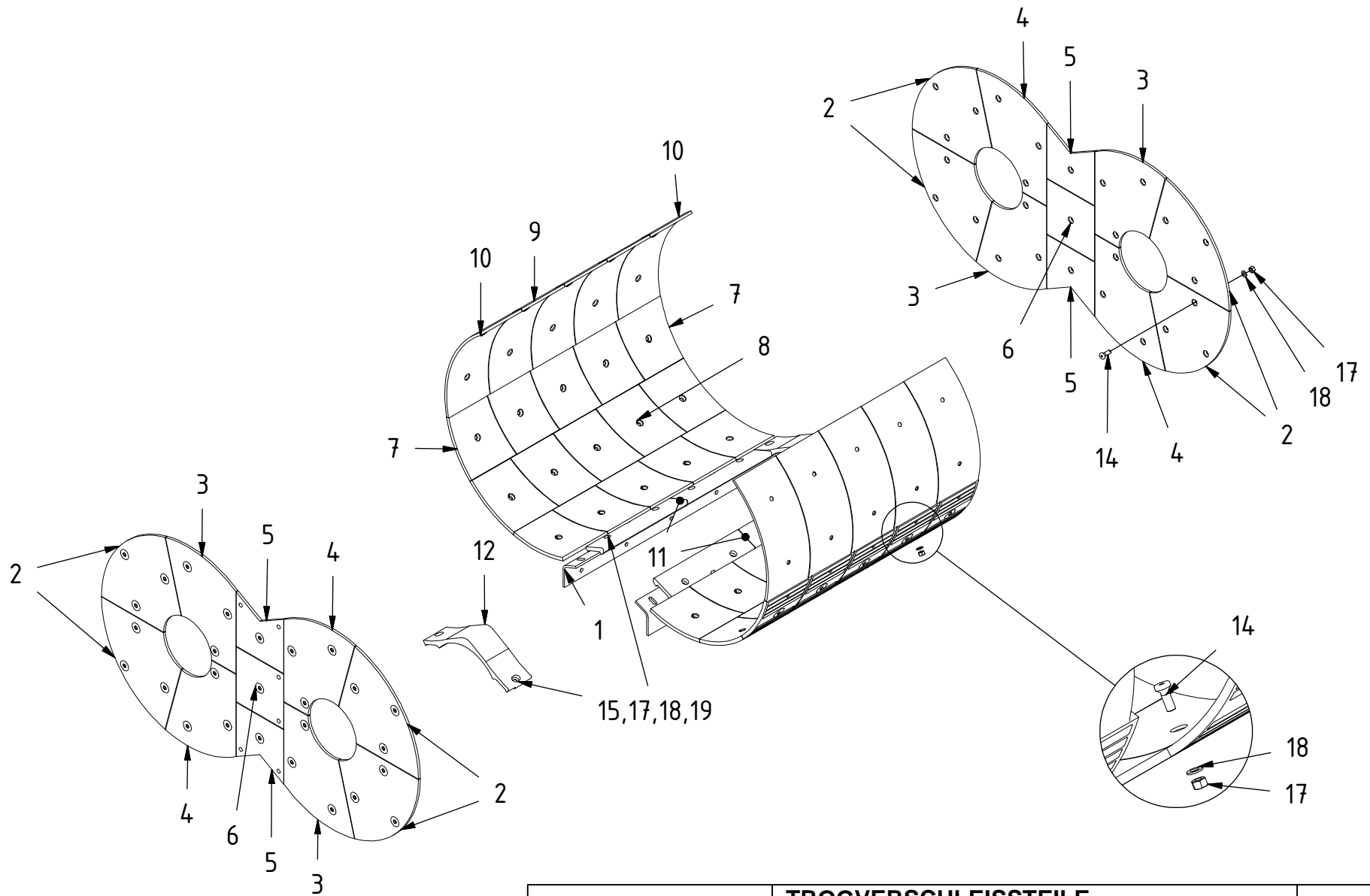

DKX 1,25	<b>TROGVerschleISSTEILE</b> TROUGH WEARING PARTS	<b>BHS</b> SONTHOFEN
<b>902026359 001 A</b>	ERSATZTEILZEICHNUNG SPARE PARTS DRAWING	



Pos	QTY	Part #	ARTICLE SHORT DESCRIPTION	DIM/TYPE	MATERIAL	STANDARD	WEIGHT
1	1	100571700	DISCHARGE DOOR CYLINDER		GG25		278,00
2	1	100579500	DISCHARGE DOOR BOLT		S355J0		8,90
3	1	100579400	DISCHARGE DOOR BOLT		S355J0		10,80
4	6	100572500	ROLLER PROTECTION		W4 D		8,00
6	2	200023390	PLUMMER BLOCK UNIT COMPLETE	RASE 70 S			7,80
8	12	100578200	COUNTERSUNK SCREW		8.8		0,14
9	12	503041600	HEXAGON NUT	M16	8, VERZ.	DIN 934	0,04
10	12	503361600	SPRING RING	A 16-VSK	FST/DACROM	DIN 128*	0,01
11	4	500031900	HEXAGON BOLT	M20X 80	8,8, VERZ.	DIN 931	0,26
12	4	503042000	HEXAGON NUT	M20	8, VERZ.	DIN 934	0,06
13	4	503362000	SPRING RING	A 20-VSK	FST/DACROM	DIN 128*	0,01
14	4	503352000	DISK	21	ST VZ.-140	DIN 125	0,02
15	4	503441900	DISK	21	ST-VZ	DIN 7349	0,07
16	2	506117000	GIB KEY	25X14X110	C45K	DIN 6887	0,40
			<b>END OF BOM!</b>				

<b>SPARE PARTS LIST</b>	DKX 2,00	DISCHARGE ROTARY GATE	
	900553500		

Antriebsseite  
drive side  
côté commande

Antriebsgegenseite  
non drive side  
côté opposé de la commande

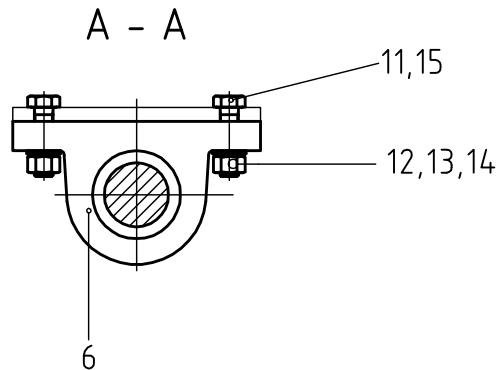
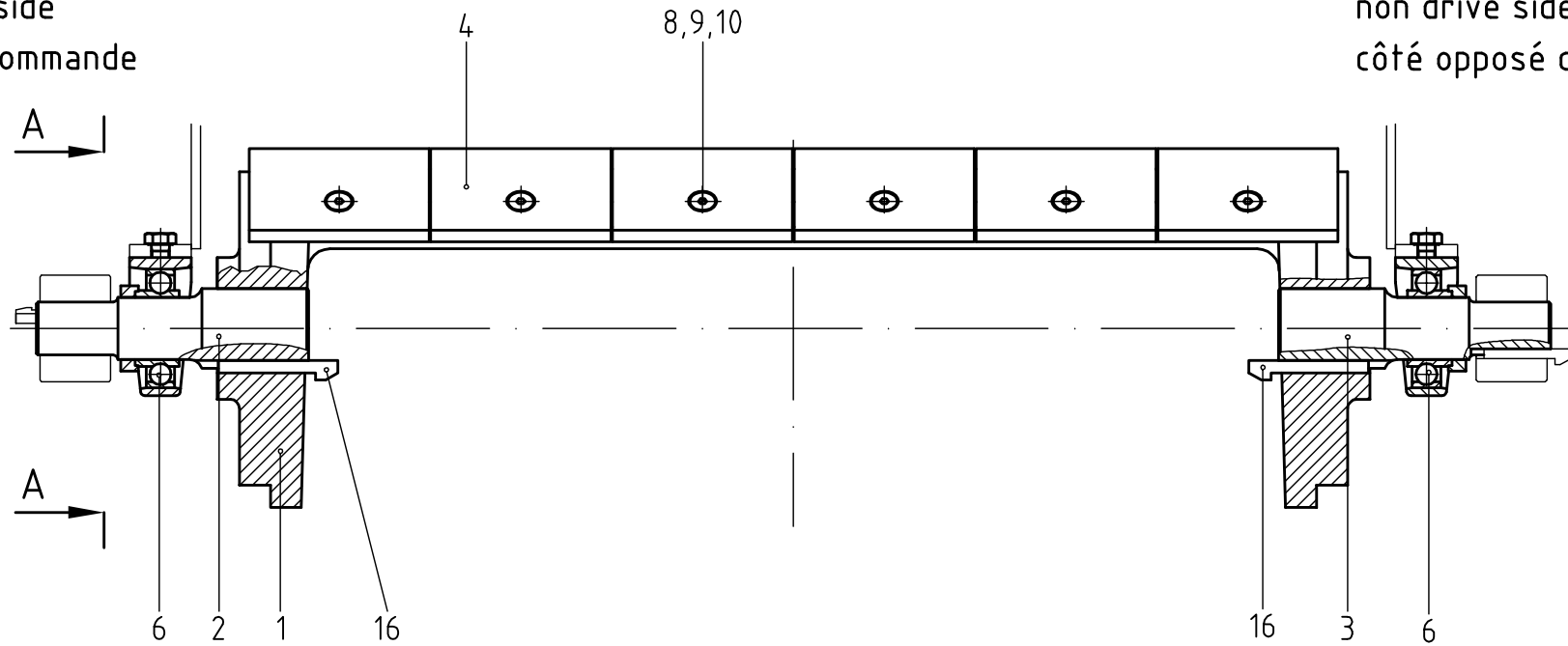

DKX 2,00	ENTLEERSCHIEBER	
900553500001B	ERSATZTEILZEICHNUNG	

Pos	QTY	Part #	ARTICLE SHORT DESCRIPTION	DIM/TYPE	MATERIAL	STANDARD	WEIGHT
1	1	100372500	LEVER		GGG40		6,40
2	1	506114900	GIB KEY	18X11X 80	C45K	DIN 6887	0,17
3	2	504312700	COUNTERBEARING		GG-25	-	0,81
4	1	100629400	CONTACT LEVER		S235JR		0,10
5	1	100629500	CONTACT LEVER		S235JR		0,10
6	2	504311801	FORK JOINT	AIRTAC			1,32
7	2	504310201	PNEUMATIC CYLINDER	AIRTAC			7,30
8	2	504313801	SUSPENSION FIXTURE	AIRTAC			3,30
10	2	504326100	SCREW FITTING			101671028	0,03
11	2	504326600	SCREW FITTING			-	0,03
12	2	504325300	SCREW FITTING			-	0,03
13	1	541501400	HOSE	1500.000	POLYURETHAN	-	0.0
16	2	504315600	SILENCER		SI.-BRONZE	-	0,02
17	1	504315010	SOLENOID VALVE	ESV 230 C B			1,00
19	3	920005293	PROXIMITY SWITCH		10-36 VDC		0,20
			<b>END OF BOM!</b>				

## SPARE PARTS LIST

DKX 1,25

DISCHARGE DOOR OPERATION  
PNEU.

902022614

SPARE PARTS DRAWING



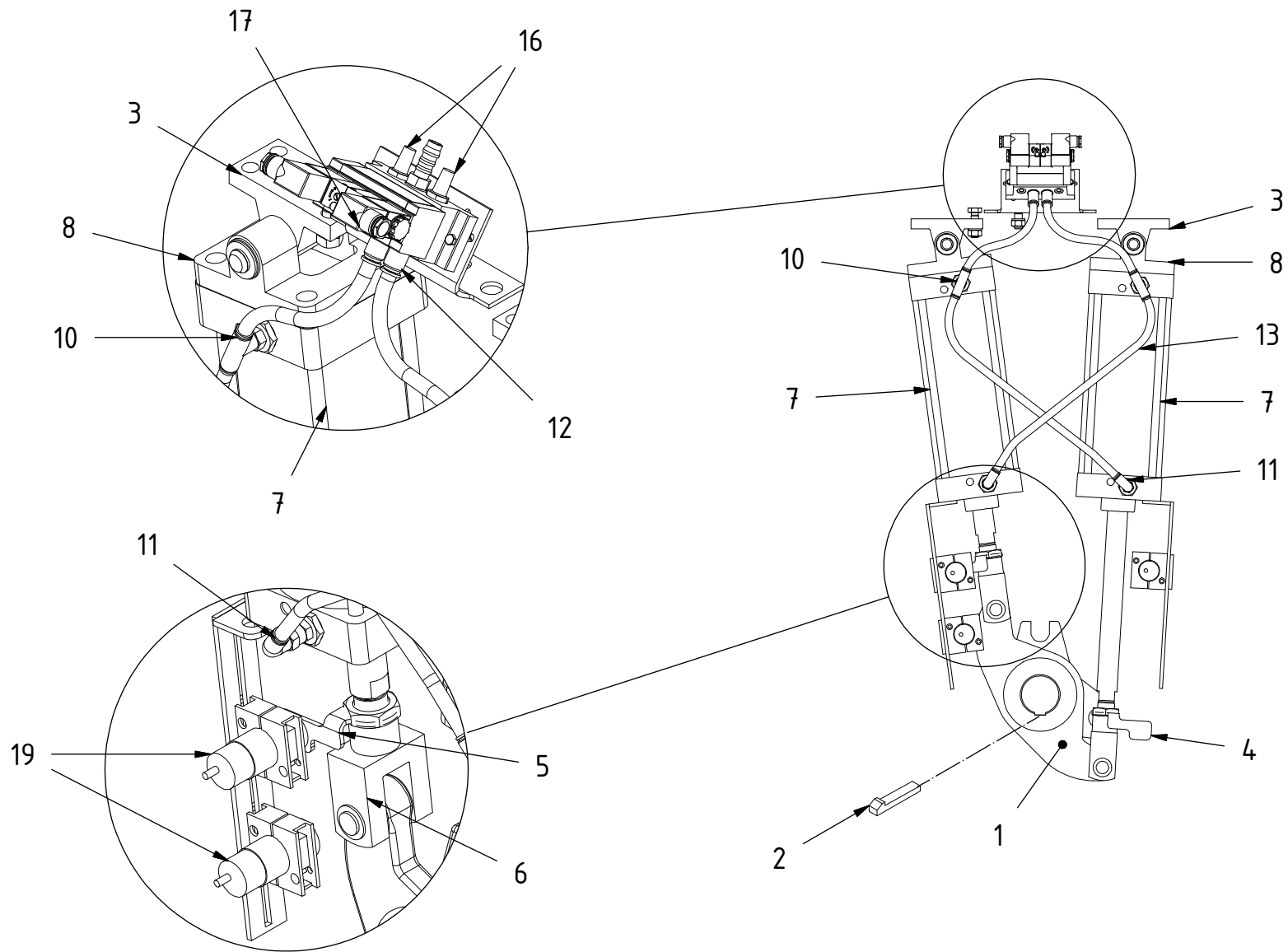

DKX 1,25	<b>ENTLEERSCHIEBERBETAETIG. PNEU.</b> DISCHARGE DOOR OPERATION PNEU.	<b>BHS</b> SONTHOFEN
<b>902022614 001 A</b>	ERSATZTEILZEICHNUNG SPARE PARTS DRAWING	

Pos	QTY	Part #	ARTICLE SHORT DESCRIPTION	DIM/TYPE	MATERIAL	STANDARD	WEIGHT
1	2	100359400	MIXING SHAFT		42CRMO4V		202,00
2	2	902015128	BEARING				
3	2	902015130	BEARING				
4	4	506104500	WEDGE	A12X 8X 25	C45K	DIN 6886	0,02
			<b>END OF BOM!</b>				

<b>SPARE PARTS LIST</b>	DKX 1,25	MIXING SHAFT WITH BEARING	
	902015131		

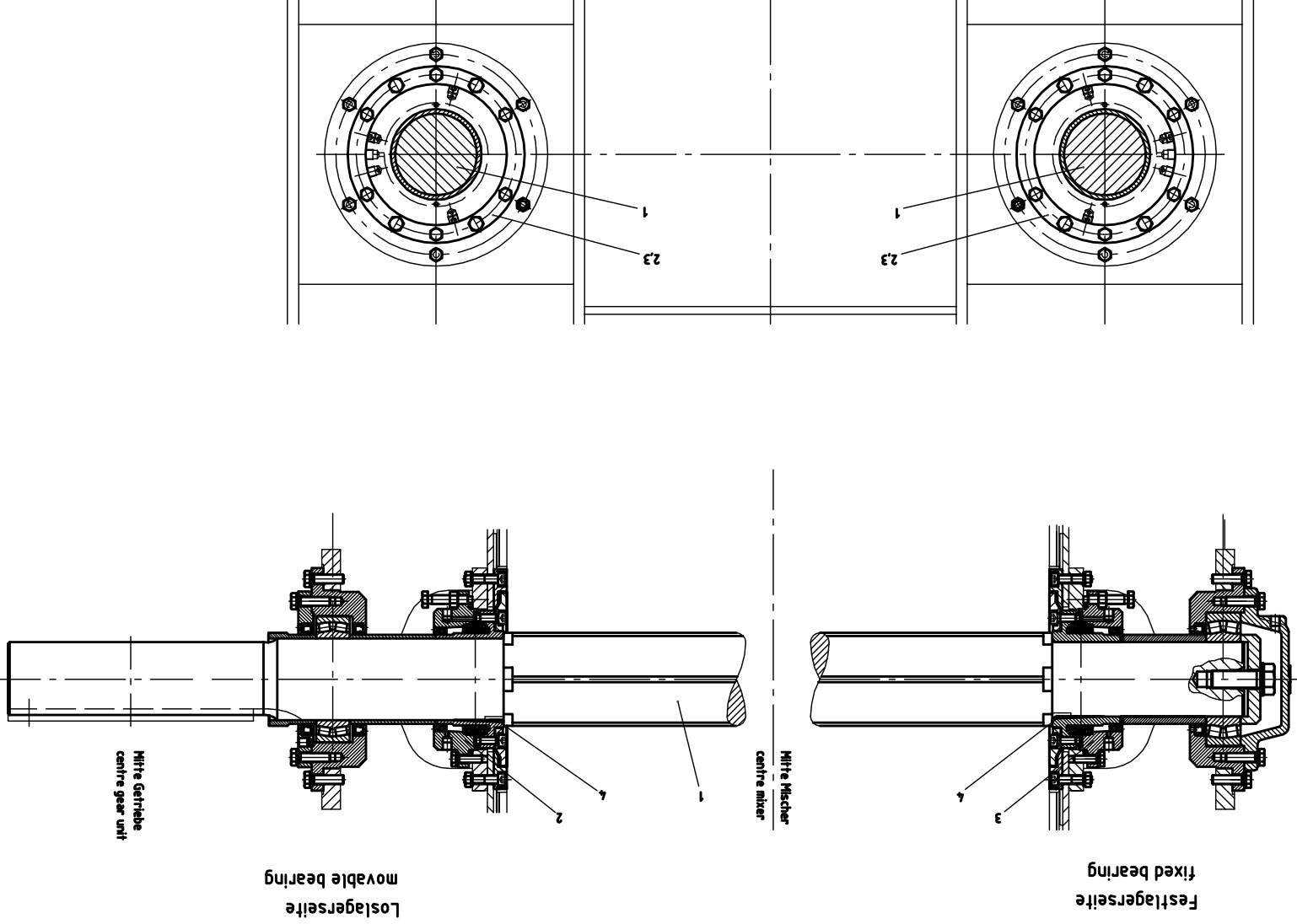

Pos	QTY	Part #	ARTICLE SHORT DESCRIPTION	DIM/TYPE	MATERIAL	STANDARD	WEIGHT
1	1	100358800	SHAFT BUSH		GGG40		5,00
2	1	101115100	RETAINING RING		GGG40		6,60
3	1	101050900	SEALING RING				0,05
4	1	100358700	BEARING BOX		GG25		13,40
5	1	100016100	BEARING COVER		GG-25		3,00
7	1	100358500	DISTANCE SLEEVE		ST 52.0		1,65
8	2	100262200	DUST COVER		W4D		1,10
9	2	100262100	WEARING RING		W4		1,70
10	1	504301000	AXIAL FACE SEAL		HARTGUSS	-	0,50
12	2	507078100	SHAFT SEALING RING	C120X150X13	NBR		0,00
13	1	910249200	SELF-ALIGNING ROLLER BRG.	23022		DIN 635	3,00
14	4	500505700	CYLINDER HEAD SCREW	M10X 25	8.8 VERZ.	DIN 912	0,03
15	6	500506100	CYLINDER HEAD SCREW	M10X 45	8.8 VERZ.	DIN 912	0,04
16	12	500133600	HEXAGON BOLT	M12X 45	8.8, VERZ.	DIN 933	0,05
17	6	500130600	HEXAGON BOLT	M10X 35	8.8, VERZ.	DIN 933	0,03
18	6	503041000	HEXAGON NUT	M10	8, VERZ.	DIN 934	0,01
19	12	503361200	SPRING RING	A 12-VSK	FST/DACROM	DIN 128*	0,00
20	12	503361000	SPRING RING	A 10-VSK	FST/DACROM	DIN 128*	0,00
22	4	500223000	HEX.BOLT FULL DOG POINT	BM12X 60	8.8 VZ	DIN 561	0,06
23	4	503041200	HEXAGON NUT	M12	8, VERZ.	DIN 934	0,02
25	1	910682400	SHAFT SEALING RING	C 120/140X13	NBR	DIN 3760	0,80
26	1	501265100	SCREW PLUG	R1/4	ST	DIN 906	0,01
			<b>END OF BOM!</b>				

## SPARE PARTS LIST

DKX 1,25

BEARING

902015128



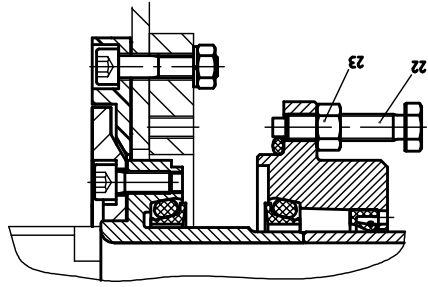
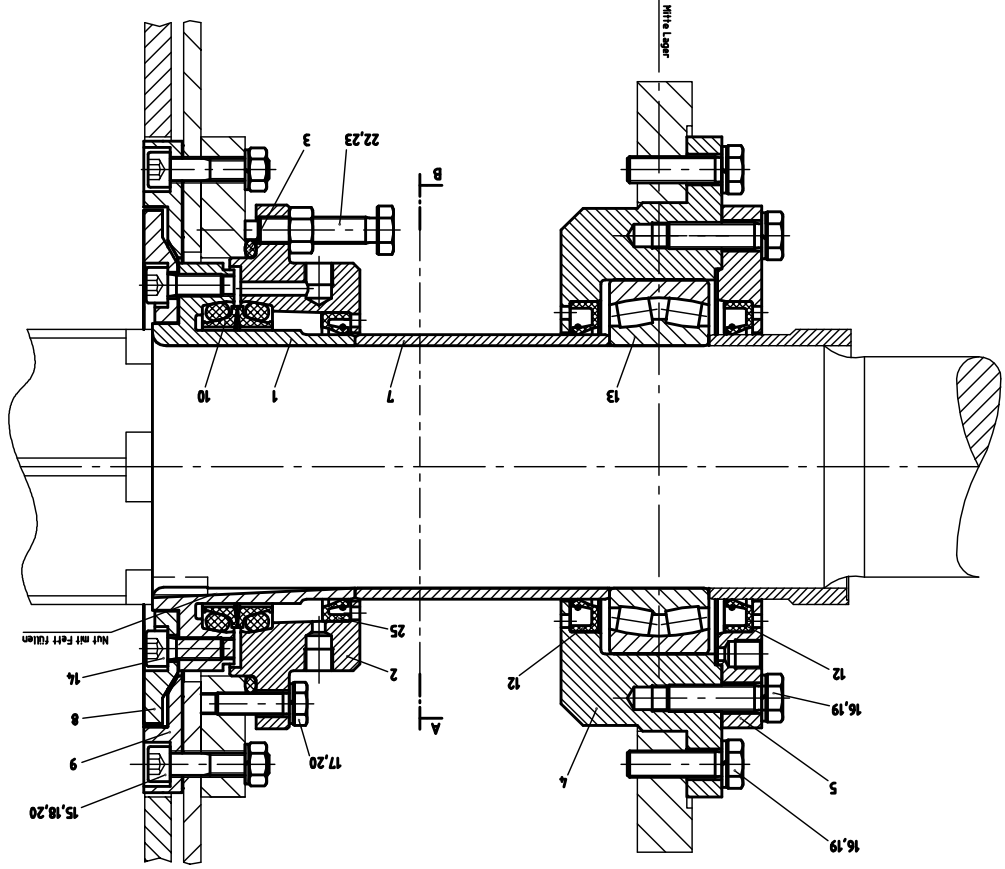
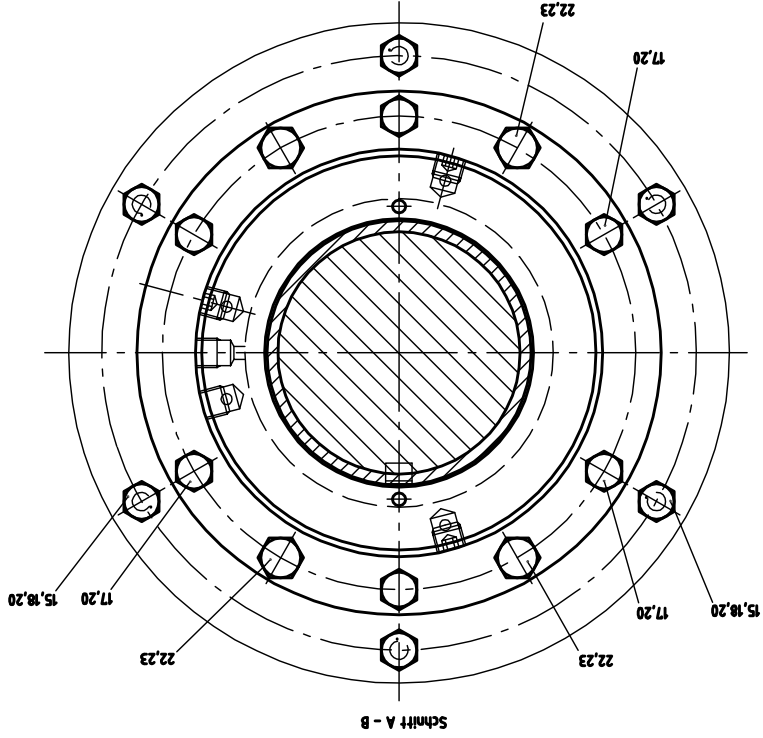

Loslagerseite



Pos	QTY	Part #	ARTICLE SHORT DESCRIPTION	DIM/TYPER	MATERIAL	STANDARD	WEIGHT
1	1	504301000	AXIAL FACE SEAL		HARTGUSS	-	0,50
2	1	910682400	SHAFT SEALING RING	C 120/140X13	NBR	DIN 3760	0,80
3	1	507078100	SHAFT SEALING RING	C120X150X13	NBR		0,00
4	1	506771400	SELF-ALIGNING ROLLER BRG.	22220 CC/W33		DIN 635	5,16
6	4	500505700	CYLINDER HEAD SCREW	M10X 25	8.8 VERZ.	DIN 912	0,03
7	6	500130600	HEXAGON BOLT	M10X 35	8.8, VERZ.	DIN 933	0,03
8	12	500133600	HEXAGON BOLT	M12X 45	8.8, VERZ.	DIN 933	0,05
10	12	503361000	SPRING RING	A 10-VSK	FST/DACROM	DIN 128*	0,00
11	12	503361200	SPRING RING	A 12-VSK	FST/DACROM	DIN 128*	0,00
13	1	100016300	SHAFT BUSH		GGG40		5,00
14	1	101115100	RETAINING RING		GGG40		6,60
15	2	100262200	DUST COVER		W4D		1,10
16	1	500142700	HEXAGON BOLT	M24X 70	8.8, VERZ.	DIN 933	0,33
17	1	503346400	LOCK WASHER	M 24 /DA 39,0	ST VZ	DIN 25201	0,02
18	1	100016700	END DISK		S355J2G3		1,00
19	1	100016800	BEARING COVER		GG-25		7,00
20	1	100016500	BEARING BOX		GG-25		13,00
21	1	101132300	DISTANCE SLEEVE		ST 52.0		3,00
22	1	504305700	LAMINUM ADJUSTING RING		G1/STAHL	-	0,11
23	1	501265100	SCREW PLUG	R1/4	ST	DIN 906	0,01
24	6	500506100	CYLINDER HEAD SCREW	M10X 45	8.8 VERZ.	DIN 912	0,04
25	6	503041000	HEXAGON NUT	M10	8, VERZ.	DIN 934	0,01
26	2	100262100	WEARING RING		W4		1,70
28	1	101050900	SEALING RING				0,05

## SPARE PARTS LIST

DKX 1,25

BEARING

902015130



30	4	500223000	HEX.BOLT FULL DOG POINT		BM12X 60	8.8 VZ	DIN 561	0,06
31	4	503041200	HEXAGON NUT		M12	8, VERZ.	DIN 934	0,02
			<b>END OF BOM!</b>					

<b>SPARE PARTS LIST</b>	DKX 1,25	BEARING	
	902015130		

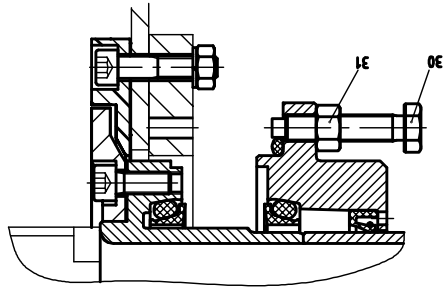
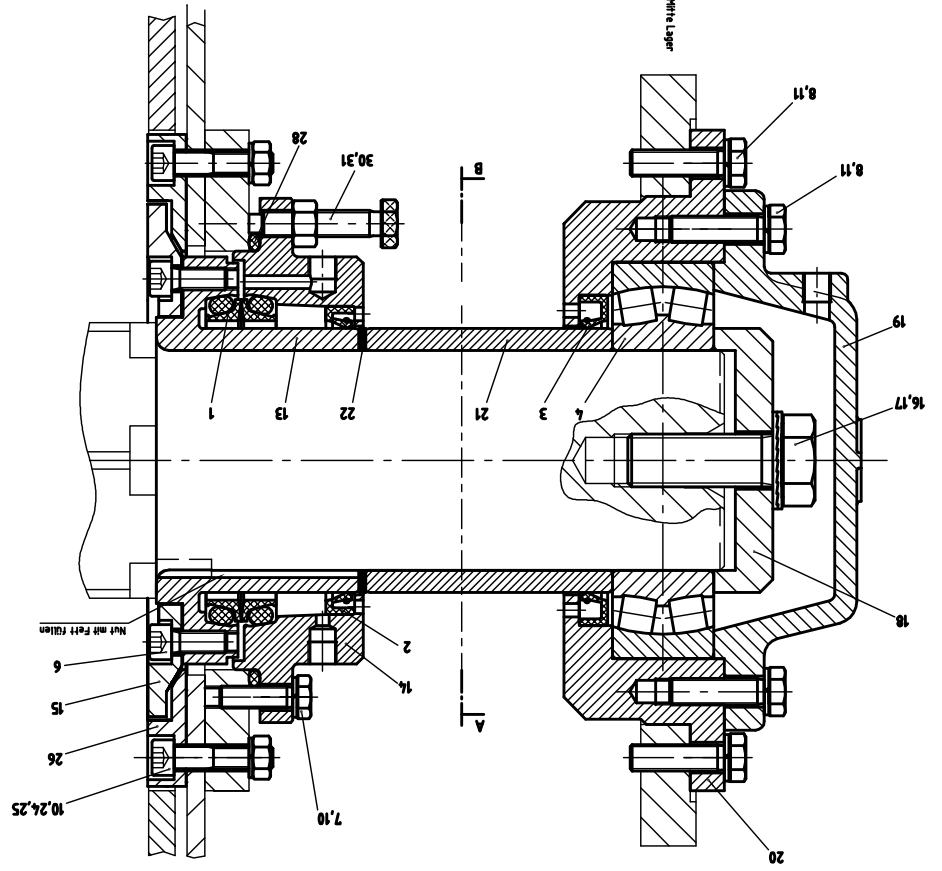
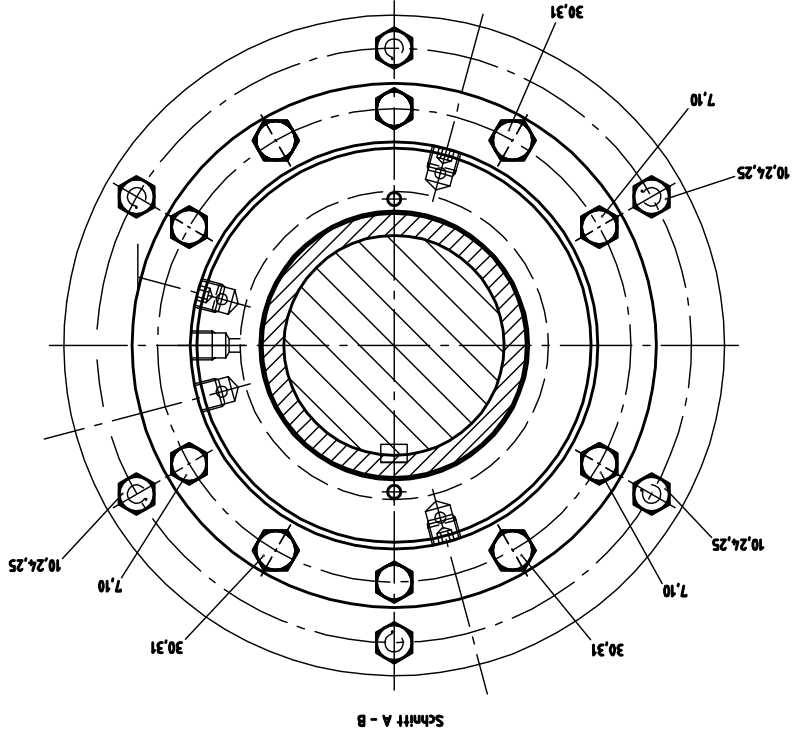

Festlagerseite

Pos	QTY	Part #	ARTICLE SHORT DESCRIPTION	DIM/TYPE	MATERIAL	STANDARD	WEIGHT
1	2	200005614	LATERAL ARM				38,90
2	1	902005583	COMPONENTS				
3	2	200005615	LATERAL ARM				36,00
4	1	902005584	COMPONENTS				
5	2	200005616	LATERAL ARM				35,00
6	1	902005585	COMPONENTS				
7	8	200005663	CENTRAL ARM				28,20
8	1	902005586	COMPONENTS				
9	6	100355300	COUNTERPART		GS60.3		9,90
10	8	200005777	COUNTERPART		GS 60		8,90
11	56	500032200	HEXAGON BOLT	M20X110	8.8 VERZ	DIN 931	0,33
12	56	503042000	HEXAGON NUT	M20	8, VERZ.	DIN 934	0,06
13	56	503435600	SPHERICAL DISK	C 21	ST	DIN 6319	0,02
14	8	200006953	FILLING-UP PIECE		GS-60		2,70
16	4	500532200	CYLINDER HEAD SCREW	M 8X 30	A 4	DIN 912	0,02
17	4	500532411	CYLINDER HEAD SCREW	M 8X 40	A4-70	DIN 912	0,02
			<b>END OF BOM!</b>				

## SPARE PARTS LIST

DKX 1,25

MIXING TOOLS

902007436



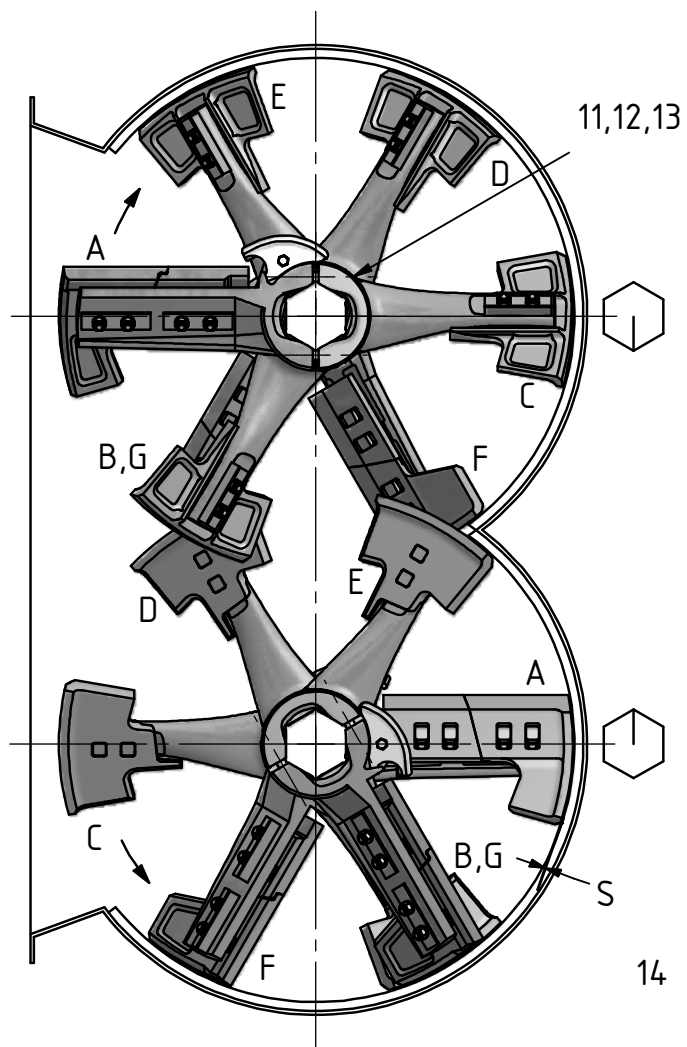

Markierung auf der antriebsseitigen Mischwellen Stirnseite zur Einstellung des Mischwerks (Kerbe zeigt zur Mitte)  
 Marks on drive end mixing shaft face to adjust the mixing tools (notch points to the centre)

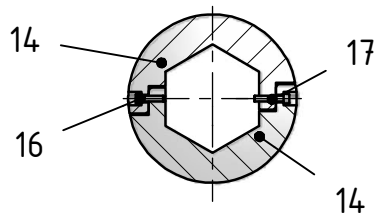

Maß s = 3mm an der engsten Stelle  
 dimension s = 3mm at narrowest point

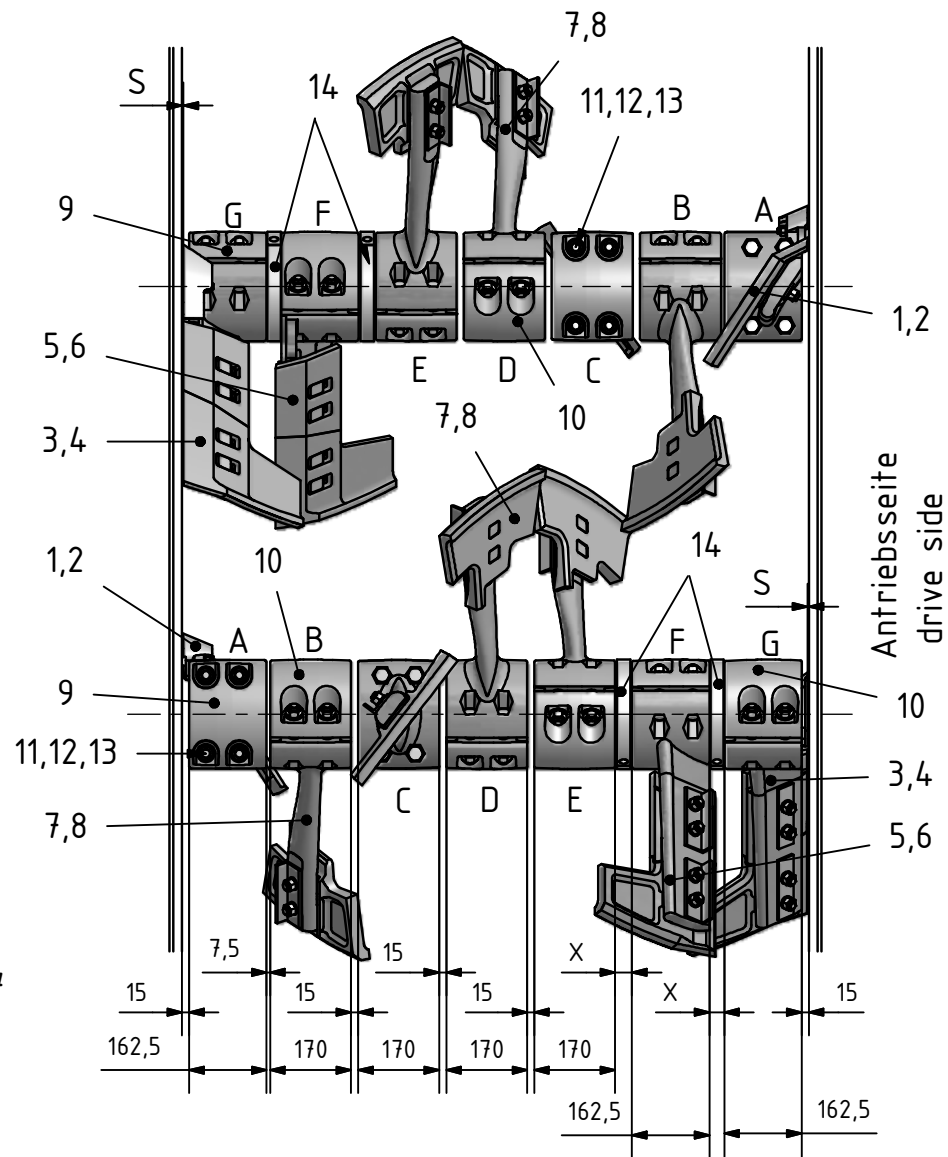

Stirnwandauskleidung lining of front walls:	Blech metal plate	Gußkacheln cast tiles
Maß X dimension X	34,5 mm	31,5 mm

DKX 1,25
<b>902007436 000 B</b>

<b>MISCHWERK</b>
ERSATZTEILZEICHNUNG



Pos	QTY	Part #	ARTICLE SHORT DESCRIPTION	DIM/TYPE	MATERIAL	STANDARD	WEIGHT
1	1	200005683	LATERAL ARM		GS 60		22,40
2	1	200005684	LATERAL BLADE		W 4		8,40
3	1	200005685	LATERAL PLATE		W 4		5,30
4	4	200005682	MIXING BLADE SCREW		8.8		0,21
5	2	200005718	SHIM		S235JRG2		0,21
6	1	100352900	ARM PROTECTION RIGHT		W4		1,34
7	4	503041600	HEXAGON NUT	M16	8, VERZ.	DIN 934	0,04
8	4	503361600	SPRING RING	A 16-VSK	FST/DACROM	DIN 128*	0,01
9	1	500133700	HEXAGON BOLT	M12X 50	8,8, VERZ.	DIN 933	0,05
10	1	503441700	DISK	13	ST-VZ	DIN 7349	0,03
11	1	503041200	HEXAGON NUT	M12	8, VERZ.	DIN 934	0,02
			<b>END OF BOM!</b>				

## SPARE PARTS LIST

DKXS1,00

COMPONENTS

902005583



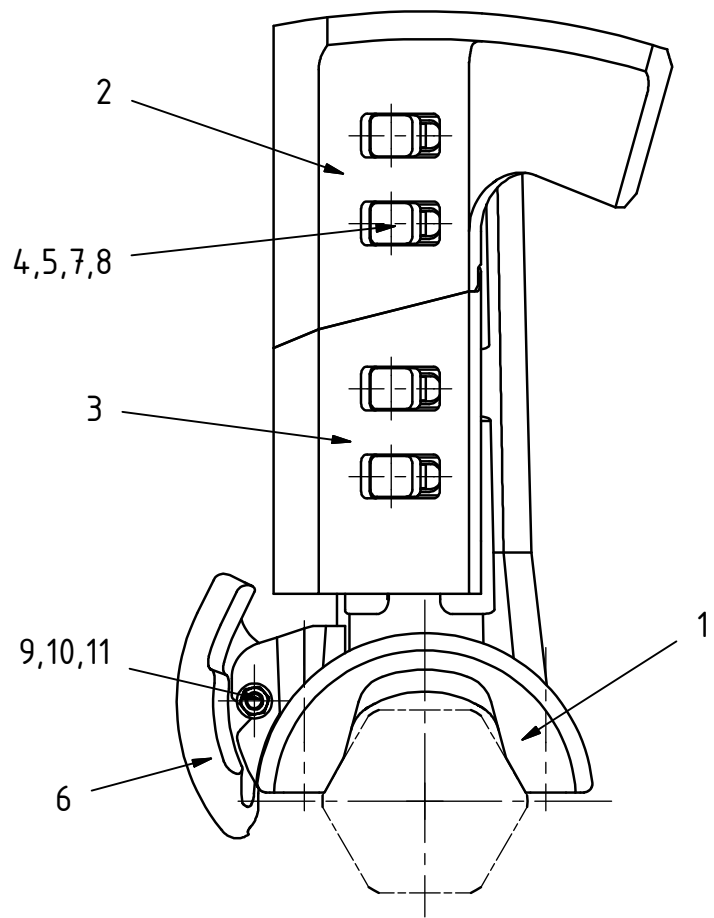

DKXS1,00	<b>EINZELTEILE SEITENARM RECHTS</b>	<b>BHS</b> <b>SONTHOFEN</b>
<b>902005583 000 A</b>	ERSATZTEILZEICHNUNG	

Pos	QTY	Part #	ARTICLE SHORT DESCRIPTION	DIM/TYPE	MATERIAL	STANDARD	WEIGHT
1	1	200005731	LATERAL ARM		GS 60		20,90
2	1	200005732	LATERAL BLADE		W 4		7,80
3	1	200005733	LATERAL PLATE		W 4		4,50
4	4	200005682	MIXING BLADE SCREW		8.8		0,21
5	2	200005718	SHIM		S235JRG2		0,21
6	1	100260800	ARM PROTECTION LEFT		W4		1,36
7	4	503041600	HEXAGON NUT	M16	8, VERZ.	DIN 934	0,04
8	4	503361600	SPRING RING	A 16-VSK	FST/DACROM	DIN 128*	0,01
9	1	500133700	HEXAGON BOLT	M12X 50	8.8, VERZ.	DIN 933	0,05
10	1	503351200	DISK	13	ST VZ.-140	DIN 125	0,01
11	1	503041200	HEXAGON NUT	M12	8, VERZ.	DIN 934	0,02
			<b>END OF BOM!</b>				

## SPARE PARTS LIST

DKXS1,00

COMPONENTS

902005584





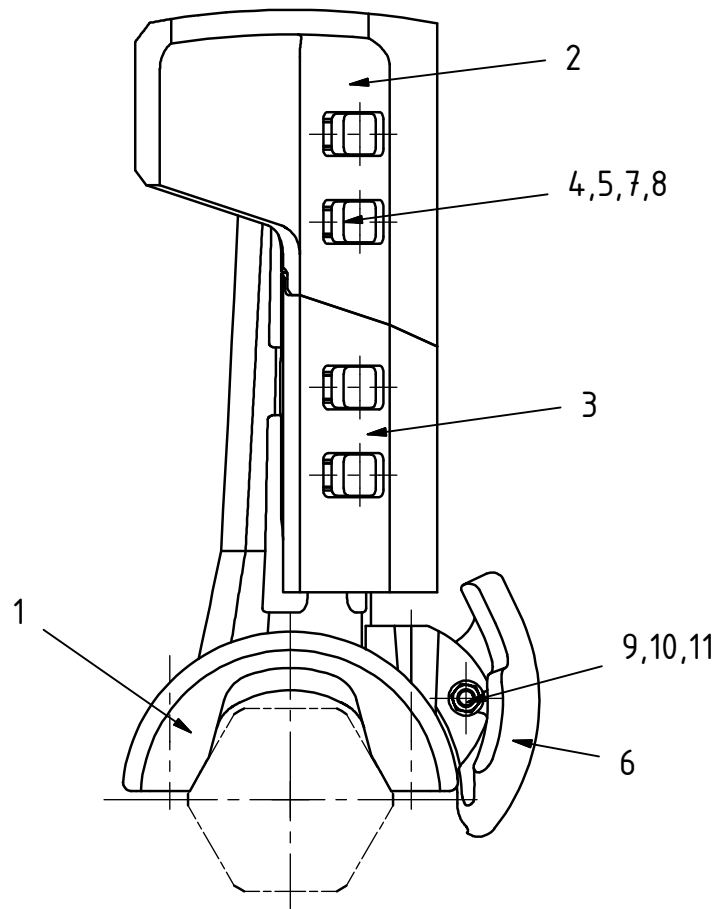

DKXS1,00	EINZELTEILE SEITENARM LINKS	<b>BHS</b> <b>SONTHOFEN</b>
902005584 000 A	ERSATZTEILZEICHNUNG	

Pos	QTY	Part #	ARTICLE SHORT DESCRIPTION	DIM/TYPE	MATERIAL	STANDARD	WEIGHT
1	1	200005731	LATERAL ARM		GS 60		20,90
2	1	200005732	LATERAL BLADE		W 4		7,80
3	1	200005733	LATERAL PLATE		W 4		4,50
4	4	200005682	MIXING BLADE SCREW		8.8		0,21
5	2	200005747	WEAR PROTECTION		S235JRG2		0,40
6	4	503041600	HEXAGON NUT	M16	8, VERZ.	DIN 934	0,04
7	4	503361600	SPRING RING	A 16-VSK	FST/DACROM	DIN 128*	0,01
			<b>END OF BOM!</b>				

<b>SPARE PARTS LIST</b>	DKXS1,00	COMPONENTS	
	902005585		

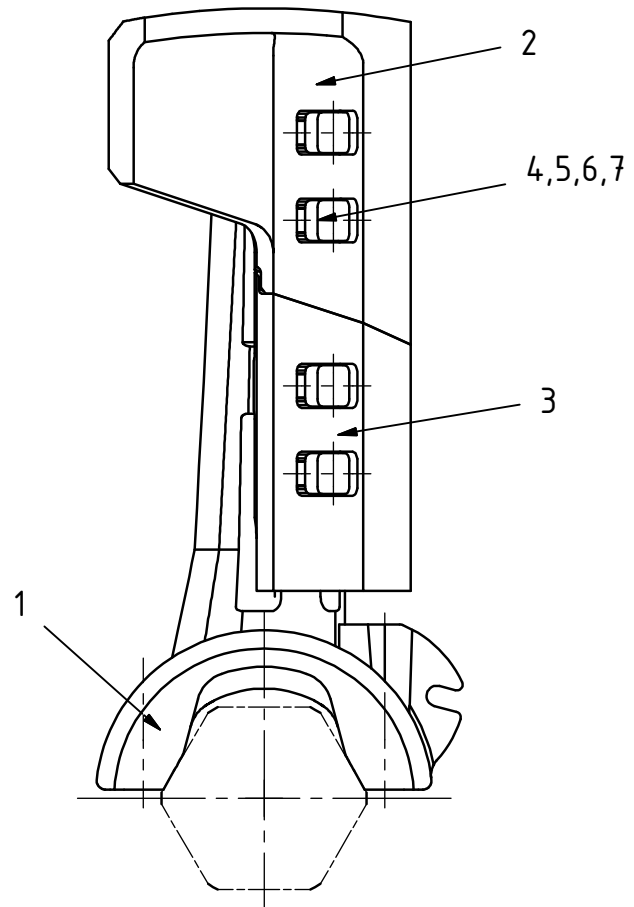

DKXS1,00	EINZELTEILE SEITENARM LINKS	<b>BHS</b> <b>SONTHOFEN</b>
902005585 000 A	ERSATZTEILZEICHNUNG	

Pos	QTY	Part #	ARTICLE SHORT DESCRIPTION	DIM/TYPE	MATERIAL	STANDARD	WEIGHT
1	1	200005664	CENTRAL ARM		GS 60		18,60
2	1	200005666	CENTRAL BLADE		W 4		8,70
3	2	200005682	MIXING BLADE SCREW		8.8		0,21
4	1	100179000	WEAR PROTECTION		UST37-2		0,40
5	2	503041600	HEXAGON NUT	M16	8, VERZ.	DIN 934	0,04
6	2	503361600	SPRING RING	A 16-VSK	FST/DACROM	DIN 128*	0,01
			<b>END OF BOM!</b>				

<b>SPARE PARTS LIST</b>	DKXS1,00	COMPONENTS	
	902005586		

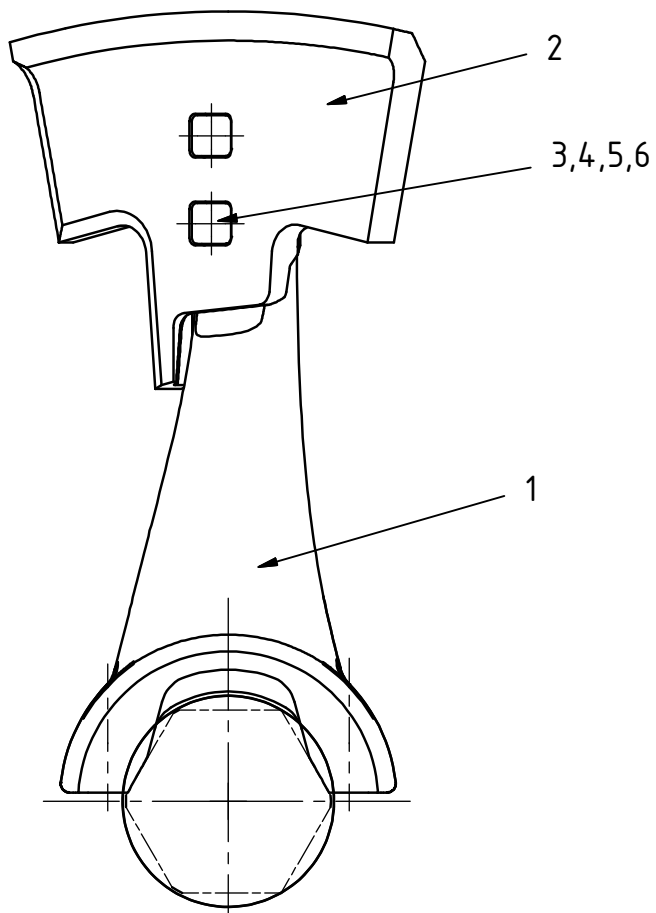

DKXS1,00	EINZELTEILE MITTELARM	<b>BHS</b> <b>SONTHOFEN</b>
<b>902005586 000 B</b>	ERSATZTEILZEICHNUNG	

Pos	QTY	Part #	ARTICLE SHORT DESCRIPTION 1	ARTICLE SHORT DESCRIPTION 2	DIM/TYPE	MATERIAL	STANDARD	WEIGHT
1	1	920011245	THREE-PHASE MOTOR	ABB				290,00
3	1	920006474	WORM GEAR		SOG 225 LI	I = 35		305,00
4	1	920006475	WORM GEAR		SOG 225 RE	I = 35		305,00
5	1	200022384	TORQUE SUPPORT LEFT COMPL	WITH MOTOR ROCKER				132,00
6	1	200022366	TORQUE SUPPORT RIGHT			S235JR (St37-2)		27,90
7	1	100609700	COUPLING					26,00
8	2	200004421	COUPLING HUB			S355JO+H		11,50
9	8	910304800	RUBBER ELEMENT		MCF 5 GG			0,30
10	32	500175200	HEXAGON BOLT		M 6X 30	8,8, VERZ.	DIN 933	0,01
11	2	501645900	THREADED PIN		M10X25	45H	DIN 914	0,01
12	1	902007046	COMPONENTS					
13	1	505760000	V-BELT PULLEY TL		SPB 236X6	GG-25	*	21,00
14	1	505794300	TENSIONING BUSH TL		NR. 3535	GG	-	5,39
15	1	505763200	V-BELT PULLEY TL		SPB 400X6	GG-25	*	33,00
16	1	505794400	TENSIONING BUSH TL		NR. 3535	GG		5,07
17	5	505734100	V-BELT		SPBX2800		DIN 7753	0,58
18	4	500032000	HEXAGON BOLT		M20X 90	8,8, VERZ.	DIN 931	0,28
19	4	503042000	HEXAGON NUT		M20	8, VERZ.	DIN 934	0,06
20	4	503352000	DISK		21	ST VZ.-140	DIN 125	0,02
21	8	503362000	SPRING RING		A 20-VSK	FST/DACROM	DIN 128*	0,01
22	12	500136200	HEXAGON BOLT		M16X 40	8,8, VERZ.	DIN 933	0,09
23	12	503361600	SPRING RING		A 16-VSK	FST/DACROM	DIN 128*	0,01
24	12	500337100	DOWEL SCREW		M16X 40	8,8	DIN 609	0,10

## SPARE PARTS LIST

DKXS1,25

DRIVE WITHOUT TURBO

902021452

SPARE PARTS DRAWING

**BHS**  
SONTHOFEN

25	12	503361800	SPRING RING		A18-VSK	FST VERZINKT	DIN 128*	0,01
27	2	100617400	END DISK			ST52-3U		1,00
28	2	500142600	HEXAGON BOLT		M24X 65	8.8, VERZ.	ISO 4017	0,32
29	2	503346400	LOCK WASHER		M24 /DA 39,0	ST VZ	DIN 25201	0,02
30	1	504305700	LAMINUM ADJUSTING RING			G1/STAHL	-	0,11
31	1	100444800	DISTANCE SLEEVE			ST 52.0		1,15
32	1	100358400	DISTANCE SLEEVE			ST 52.0		1,15
33	2	100214300	FEATHER KEY			ST50K		0,80
34	2	500553500	CYLINDER HEAD SCREW		M10X 16	8.8 VERZ.	DIN 6912	0,02
35	22,0	509507300	LUBRICATING OIL SYNTHETIC VG460		ISO-VG460			1,00
36	1	920001545	MEASURING INSTRUMENT		MESSB.500-1400N		OPTIBELT	0,30
37	1	910669400	MEASURING INSTRUMENT					0,10
<b>END OF BOM!</b>								

## SPARE PARTS LIST

DKXS1,25

DRIVE WITHOUT TURBO

902021452

SPARE PARTS DRAWING

**BHS**  
SONTHOFEN

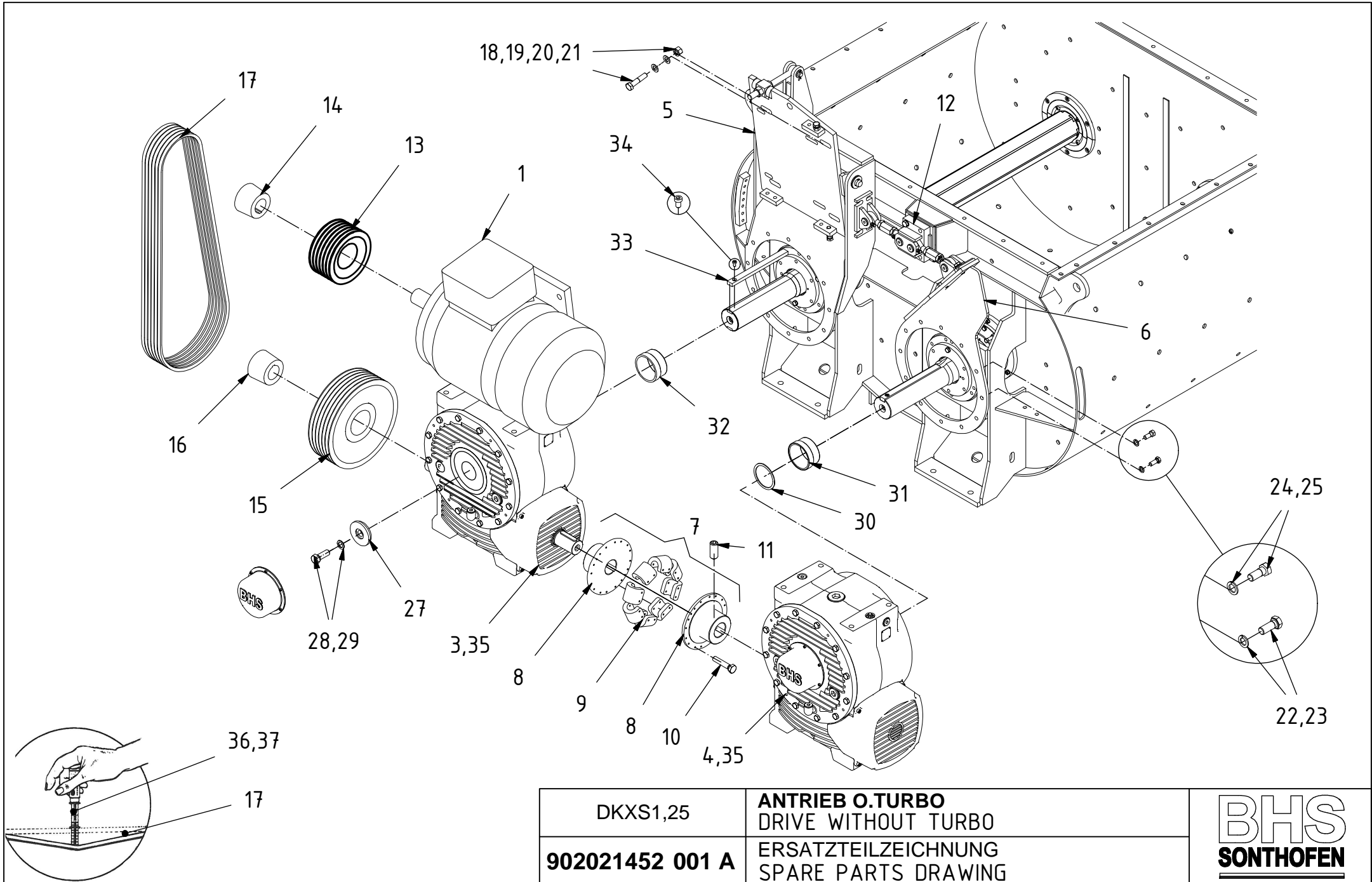

DKXS1,25  
**902021452 001 A**

**ANTRIEB O.TURBO**  
 DRIVE WITHOUT TURBO  
 ERSATZTEILZEICHNUNG  
 SPARE PARTS DRAWING





Pos	QTY	Part #	ARTICLE SHORT DESCRIPTION	DIM/TYPE	MATERIAL	STANDARD	WEIGHT
1	2	100615000	BEARING BLOCK		ST		2,80
2	8	500136200	HEXAGON BOLT	M16X 40	8.8, VERZ.	DIN 933	0,09
3	8	503351600	DISK	17	ST VZ.-140	DIN 125	0,01
4	8	503361600	SPRING RING	A 16-VSK	FST/DACROM	DIN 128*	0,01
5	1	100614900	TRESTLE		ST		7,20
6	4	500136600	HEXAGON BOLT	M16X 60	8.8, VERZ.	DIN 933	0,12
7	4	503361600	SPRING RING	A 16-VSK	FST/DACROM	DIN 128*	0,01
8	2	910211000	JOINT HEAD	SMC 25 GE/C2	RECHTS		0,65
9	2	910210900	JOINT HEAD	SMLC 25 GE/C2	LINKS		0,65
10	2	100360300	TURNBUCKLE		ST50K verzinkt		0,35
11	2	910210800	HEXAGON NUT	BM24X2	04AU Verzinkt	DIN 439	0,10
12	2	910210700	HEXAGON NUT	BM24X2	04AU Verzinkt	DIN 439	0,10
13	4	100616000	BOLT		ST52K		0,30
14	4	500177600	HEXAGON BOLT	M 8X 30	8.8, VERZ.	DIN 933	0,02
15	4	503020800	HEXAGON NUT	M 8	04, VERZ.	ISO 4035	0,00
			<b>END OF BOM!</b>				

<b>SPARE PARTS LIST</b>	DKX	COMPONENTS	
	902007046		

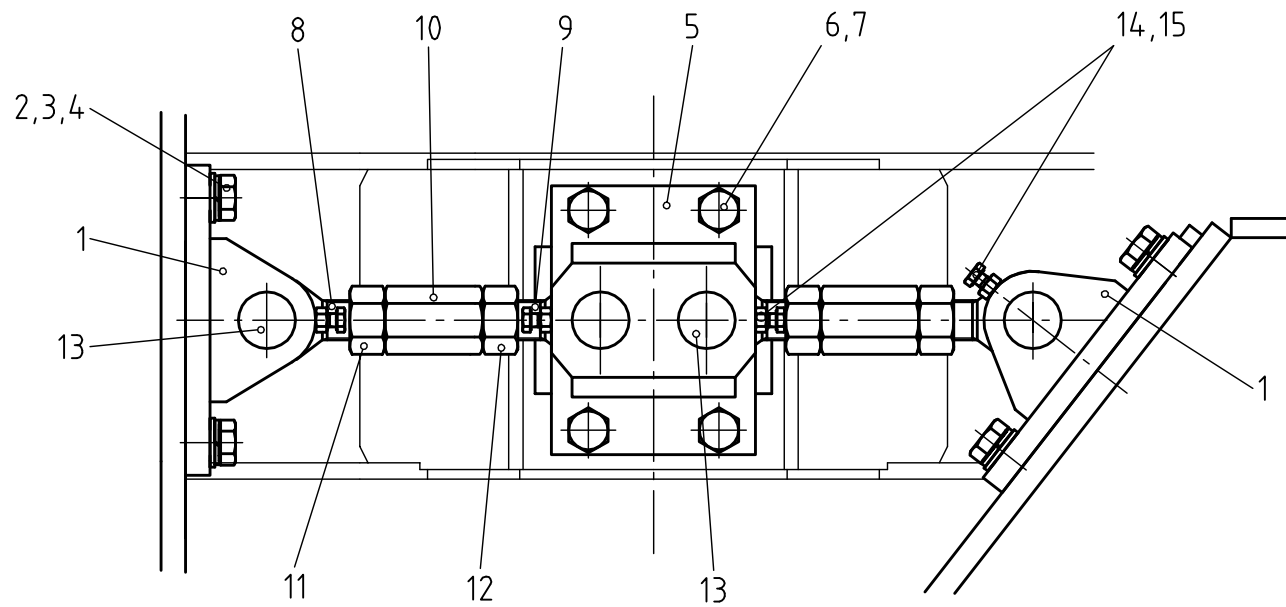

DKX	EINZELTEILE ABSTÜTZUNG	<b>BHS</b> <b>SONTHOFEN</b>
902007046 B	ERSATZTEILZEICHNUNG	

Pos	QTY	Part #	ARTICLE SHORT DESCRIPTION 1	ARTICLE SHORT DESCRIPTION 2	DIM/TYPE	MATERIAL	STANDARD	WEIGHT
1	2	507610300	SWIVELLING SCREW FITTING		WH 8-PLR	ST/A3C	-	0,12
2	5	507636500	CONICAL LUBR. HEAD		AR1/4	5.8	DIN 71412	0,01
3	1	910450300	HOSE PIPE		A0A3-1350			0,50
4	1	910692100	HOSE PIPE		A0A0-2070			0,80
5	1	910761900	HOSE PIPE		A05A05-570			0,30
6	1	920000906	HOSE PIPE		A0A0-450			0,30
7	1	920000907	HOSE PIPE		A0A3-1850			0,70
			<b>END OF BOM!</b>					

<b>SPARE PARTS LIST</b>	DKX 1,67	LUBRICATION PIPE AS	
	902023596	SPARE PARTS DRAWING	

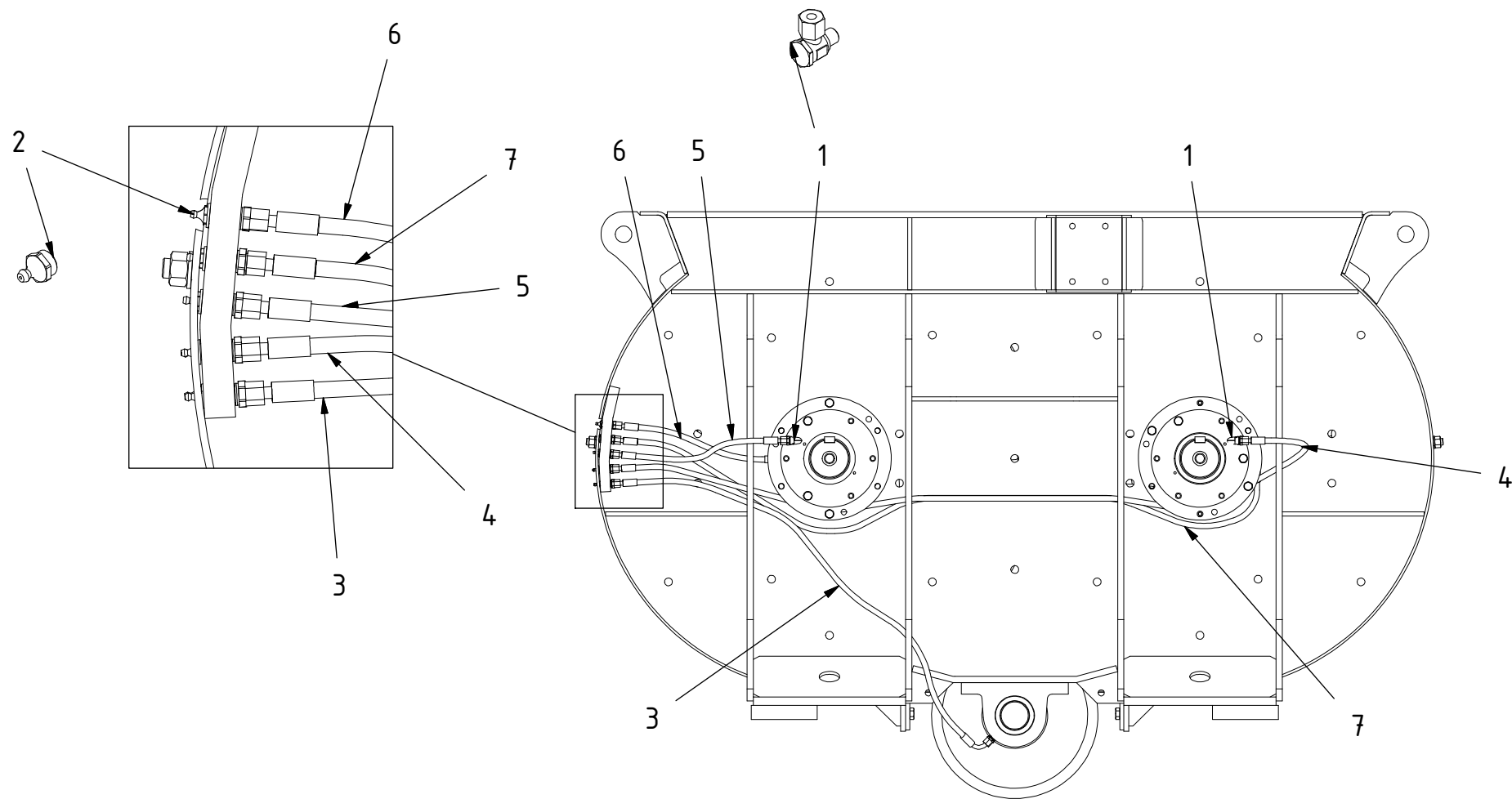

DKX 1,67	<b>SCHMIERLEITUNG AS</b> LUBRICATION PIPE AS	<b>BHS</b> SONTHOFEN
<b>902023596 001 A</b>	ERSATZTEILZEICHNUNG SPARE PARTS DRAWING	

Pos	QTY	Part #	ARTICLE SHORT DESCRIPTION 1	ARTICLE SHORT DESCRIPTION 2	DIM/TYPE	MATERIAL	STANDARD	WEIGHT
1	5	507636500	CONICAL LUBR. HEAD		AR1/4	5.8	DIN 71412	0,01
2	1	920001983	HOSE PIPE		A0A2-1450			1,10
3	1	920001116	HOSE PIPE		A0A0-1800			0,70
4	1	910815200	HOSE PIPE		A0A0-850			0,30
5	1	920000906	HOSE PIPE		A0A0-450			0,30
6	1	920000907	HOSE PIPE		A0A3-1850			0,70
			<b>END OF BOM!</b>					

<b>SPARE PARTS LIST</b>	DKX 1,67	LUBRICATION PIPE AGS	
	902023597	SPARE PARTS DRAWING	

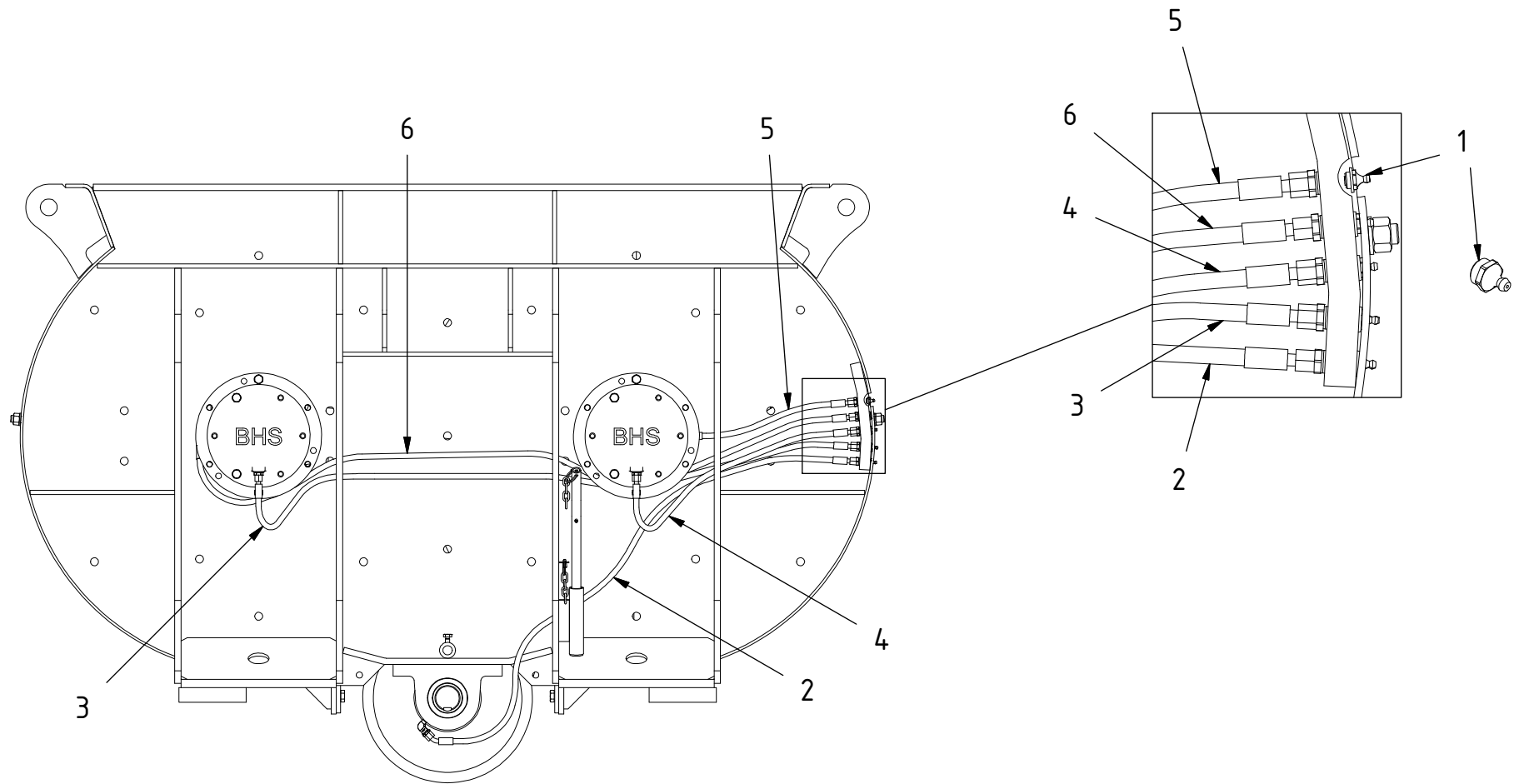

DKX 1,67	<b>SCHMIERLEITUNG AGS</b> LUBRICATION PIPE AGS	<b>BHS</b> SONTHOFEN
<b>902023597 001 A</b>	ERSATZTEILZEICHNUNG SPARE PARTS DRAWING	

Pos	QTY	Part #	ARTICLE SHORT DESCRIPTION 1	ARTICLE SHORT DESCRIPTION 2	DIM/TYPE	MATERIAL	STANDARD	WEIGHT
1	1	920005420	GREASE PUMP		10 LTR.			9,00
2	6,0	509531000	ANTIFRICT. BEARING GREASE					1,00
3	4	920006254	PUMP ELEMENT		DDB-M8/10			
4	4	910795000	CONICAL LUBR. HEAD		AR 1/4	ST/VERZ		0,01
5	2	920005043	HOSE PIPE 6		A05A05-410			0,30
6	2	920009030	HOSE PIPE 6		A0A0-1850			0,60
7	1	910222500	HOSE PIPE		A0A0-2500			1,00
8	1	920011897	HOSE PIPE		A05A05-3800			1,30
9	1	910781500	HOSE PIPE		A0A2-1950			0,70
10	1	920003318	HOSE PIPE		A0A3- 400			0,20
			<b>END OF BOM!</b>					

**SPARE PARTS LIST**

D 1,25

CENTRAL LUBRICATION  
GREASE

902029087

SPARE PARTS DRAWING



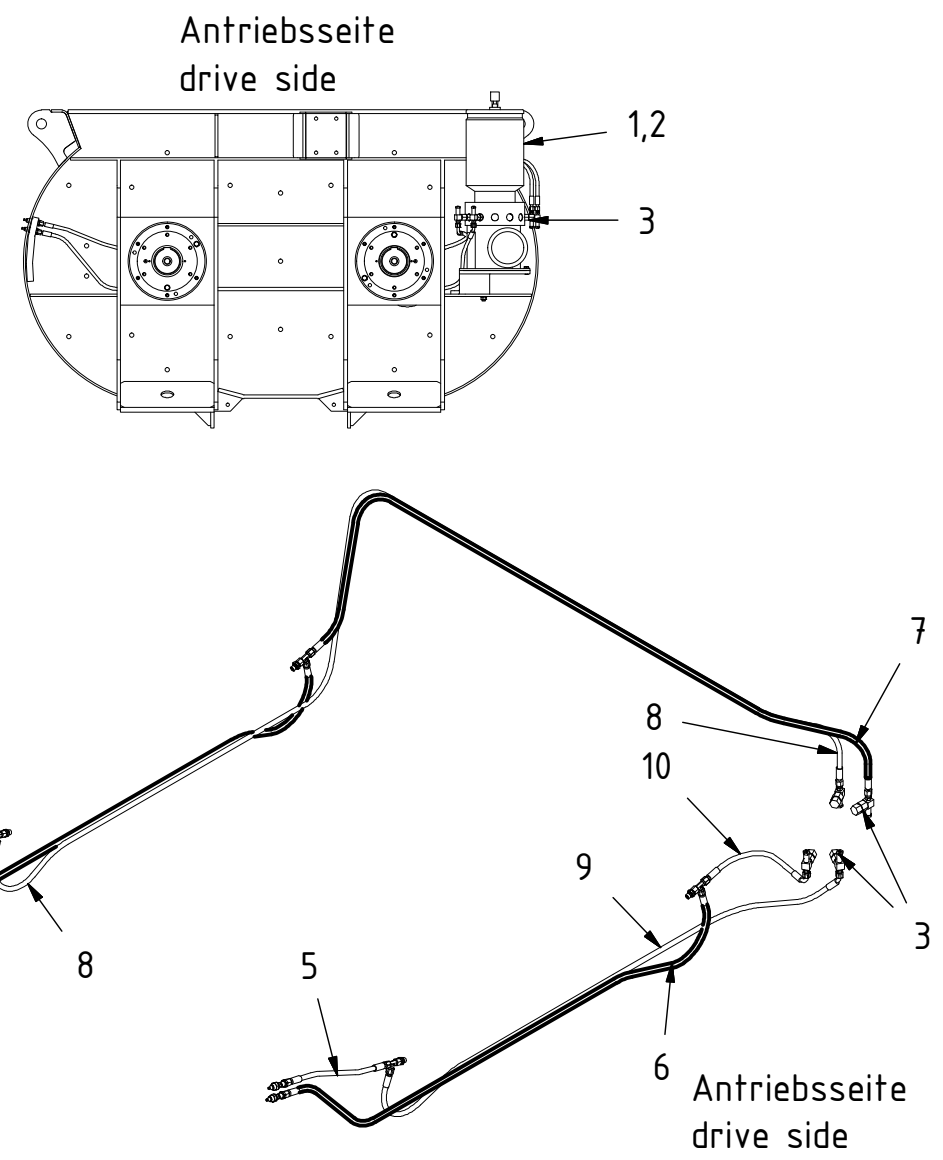
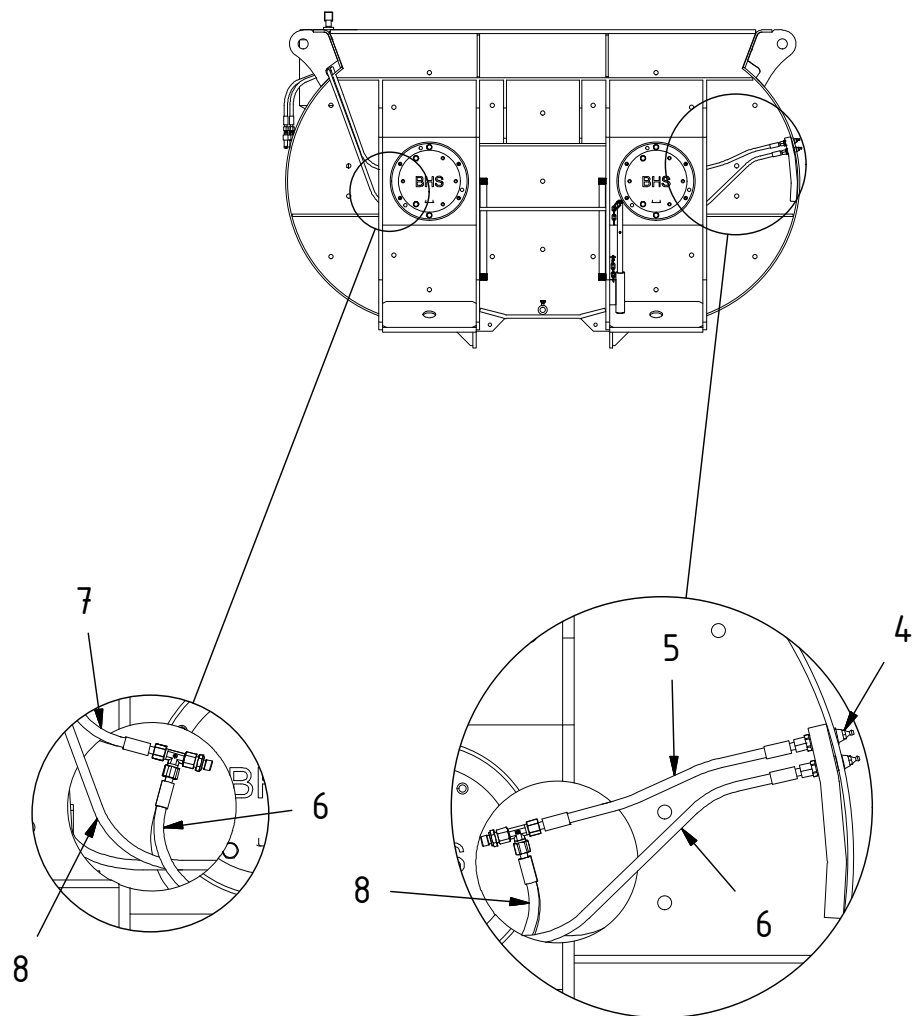

D 1,25	<b>ZENTRALSCHMIERUNG FETT</b> CENTRAL LUBRICATION GREASE	<b>BHS</b> SONTHOFEN
<b>902029087 001 A</b>	ERSATZTEILZEICHNUNG SPARE PARTS DRAWING	



## Plastic tubes and high-pressure plastic hoses

### Plastic tube (Ø 6 x 1,5 mm)

- Use the plastic tubes only in the low pressure area, i. e. between the secondary metering devices and the lubrication point.
- Adhere to the pressures and bending radii mentioned in the chapter „Technical Data“ when installing the parts.

### High-pressure plastic hoses Ø 8,6 x 2,3 mm

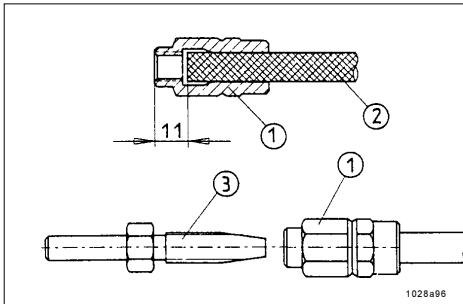

Fig. 22 - Preassembly of the threaded sleeves and hose studs on the high-pressure plastic hose

- 1 - Threaded sleeve
- 2 - High-pressure plastic hose
- 3 - Hose stud

- Use the high-pressure plastic hose only in the high pressure area, i. e. between the pump, main metering device and secondary metering devices.
- Adhere to the pressures and bending radii mentioned in the chapter „Technical Data“ when installing the parts.

#### Fitting the threaded sleeves and hose studs on the high-pressure plastic hose

- Screw the threaded sleeve, item 1 Fig. 22, counterclockwise onto the high-pressure plastic hose 2 until the illustrated dimension of 11 mm is reached. Then screw the hose stud 3 into the threaded sleeve 1.

**Important:** Before screwing the parts 1 and 3, rub them with oil.

*Note :* The outside diameter of the high-pressure plastic hose may show variations in dimension. In such a case, press the threaded sleeve 1 at the end where it will be screwed onto the high-pressure plastic hose so that it becomes oval in shape (1 to 2 mm). This will prevent the high-pressure plastic hose from being pushed out of the sleeve when the hose stud is screwed.

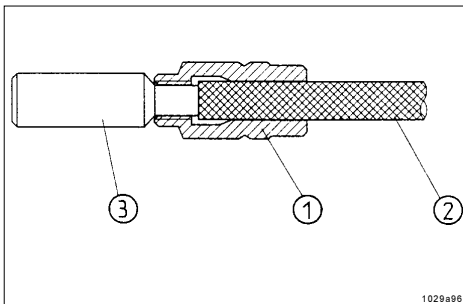



Fig. 23 - Preassembly of the threaded sleeves by means of an adjusting gauge

- 1 - Threaded sleeve
- 2 - High-pressure plastic hose
- 3 - Adjusting gauge 432-23077-1

*Note:* When using the special adjusting gauge 432-23077-1 (see Pats Catalog) screw the threaded sleeve counterclockwise onto the high-pressure plastic hose until the gauge inserted in the sleeve begins to rise.

Pos	QTY	Part #	ARTICLE SHORT DESCRIPTION 1	ARTICLE SHORT DESCRIPTION 2	DIM/TYPE	MATERIAL	STANDARD	WEIGHT
1	1	920008714	FILTER		G1/2Z			0,68
2	1	504350400	HOSE NOZZLE			MS		0,06
3	1	504325401	SCREW FITTING				-	0,05
4	1	504325201	SCREW FITTING				-	0,05
5	1	541501500	HOSE		1800.000	POLYURETH AN		0.0
			<b>END OF BOM!</b>					

<b>SPARE PARTS LIST</b>	DKX	MAINTENANCE UNIT	
	902024410	SPARE PARTS DRAWING	

Antriebsgegenseite  
Non drive side

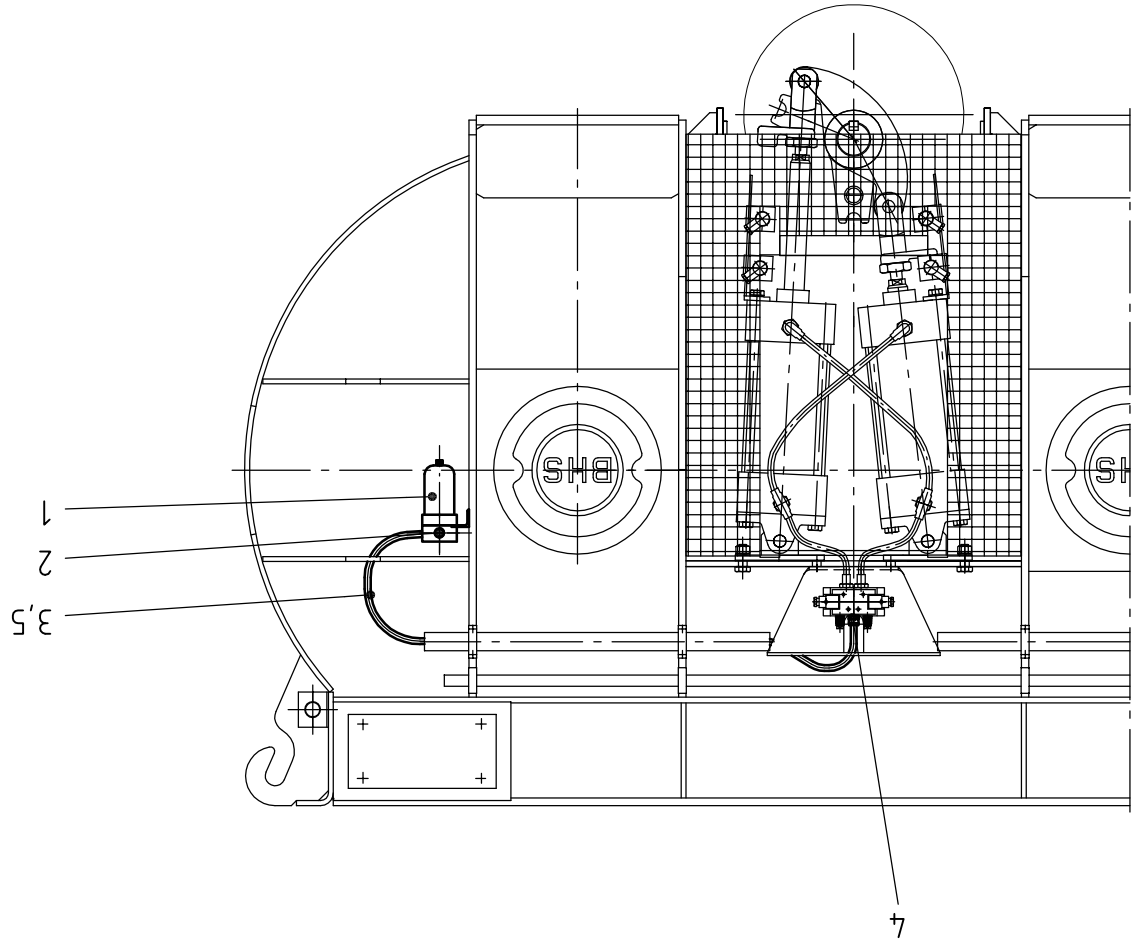

Pos	QTY	Part #	ARTICLE SHORT DESCRIPTION 1	ARTICLE SHORT DESCRIPTION 2	DIM/TYPE	MATERIAL	STANDARD	WEIGHT
1	1	200034197	RUBBER CLOTH	F. SPLASH GUARD, 40° SHORE		Gummi		1,60
2	2	500133400	HEXAGON BOLT		M12X 35	8.8, VERZ.	DIN 933	0,04
3	2	503101200	HEXAGON NUT W.CLAMP.PART		M12 (SW 19)	8, VERZ.	DINENISO70 42	0,02
4	2	503423200	DISK		13	ST, VERZ.	DIN 9021	0,03
5	2	503351200	DISK		13	ST VZ.-140	DIN 125	0,01
			<b>END OF BOM!</b>					

## SPARE PARTS LIST

DKX

SPLASH GUARD

902025609

SPARE PARTS DRAWING



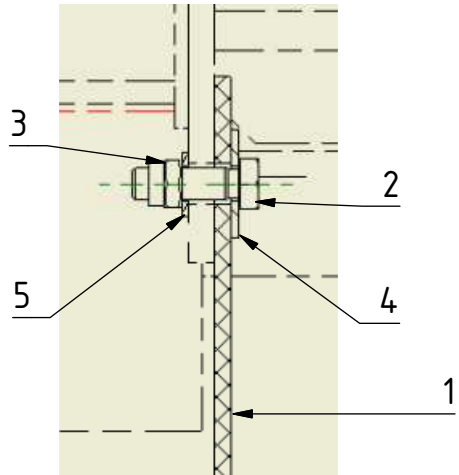
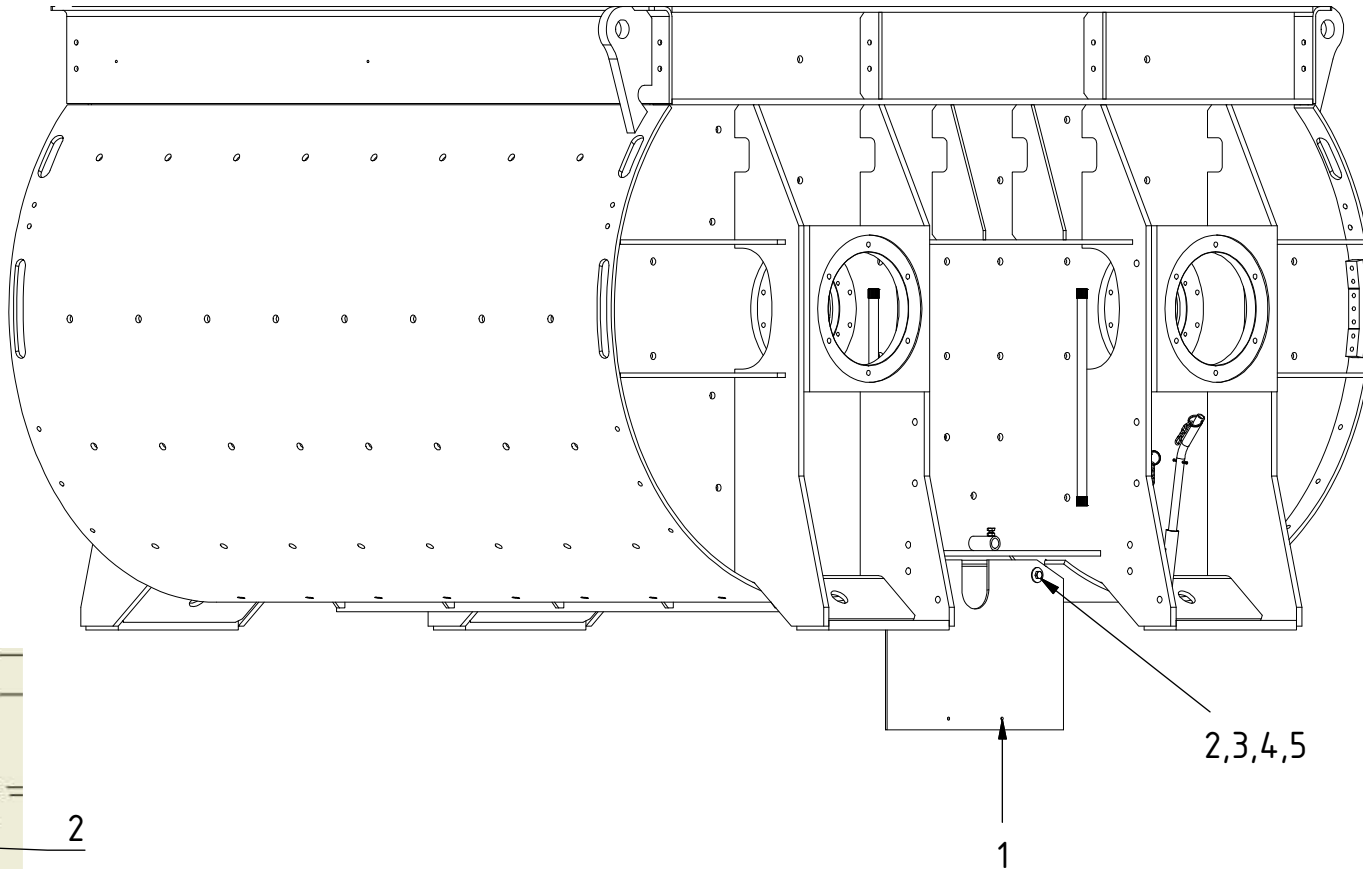

DKX	<b>SPRITZSCHUTZ</b> SPLASH GUARD	<b>BHS</b> SONTHOFEN
<b>902025609 001 A</b>	ERSATZTEILZEICHNUNG SPARE PARTS DRAWING	

Pos	QTY	Part #	ARTICLE SHORT DESCRIPTION 1	ARTICLE SHORT DESCRIPTION 2	DIM/TYPE	MATERIAL	STANDARD	WEIGHT
1	2	910002300	LIMIT SWITCH					0,28
2	2	540015600	FLAT		3600.000	FG 720	-	0.0
3	4	920008177	PNEUMATIC SPRING		250N			0,46
			<b>END OF BOM!</b>					

<b>SPARE PARTS LIST</b>	DKX	TROUGH COVER	
	902020848	SPARE PARTS DRAWING	

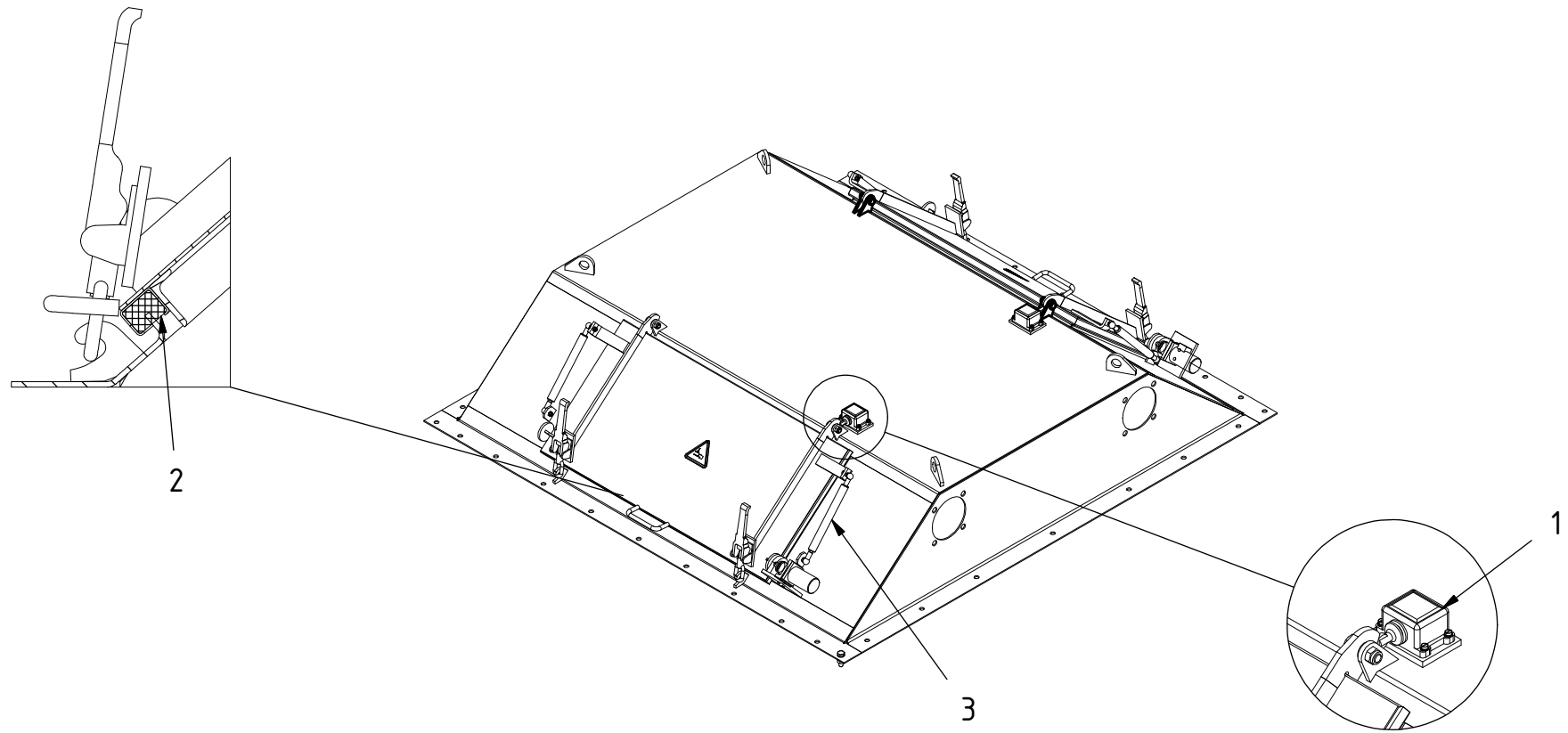

DKX	<b>TROGABDECKUNG</b> TROUGH COVER	<b>BHS</b> SONTHOFEN
<b>902020848 001 A</b>	ERSATZTEILZEICHNUNG SPARE PARTS DRAWING	