

# WIND MAXX

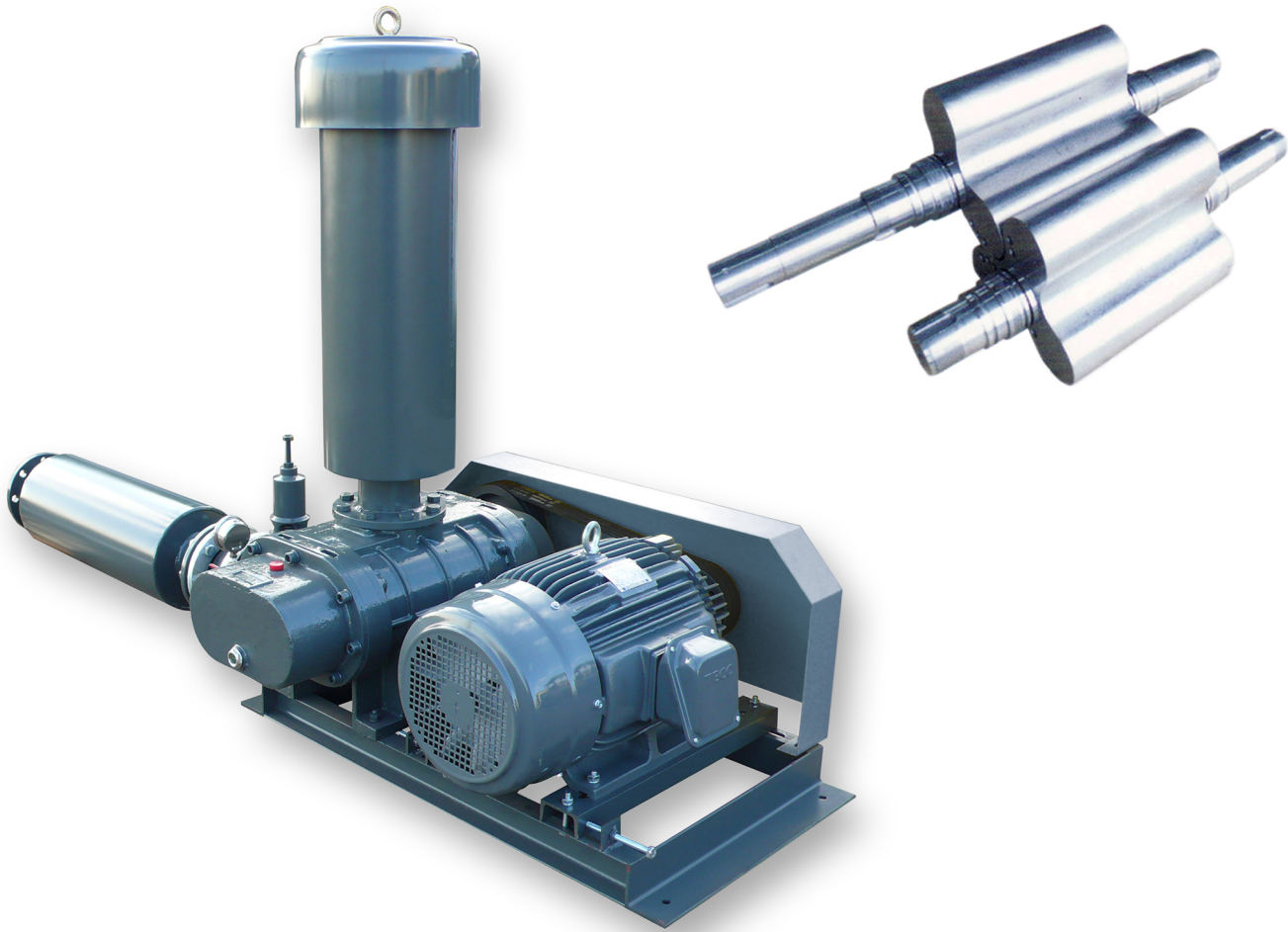

## WM-WML SERIES

### THREE LOBE ROTARY BLOWER



# THREE-LOBE ROOTS BLOWER

**WIND MAXX** is professional manufacturer for three-lobe roots blower in Taiwan, with our diligence, faith and honor for developing roots blower. blowers, And high efficiency blowers

## FEATURES :

1. Wide range of capacity, pressure, vacuum  
Bore size : 50 mm ~ 300 mm (2" to 12")  
Capacity : 1.02 ~ 264.94 m<sup>3</sup>/min  
Pressure : WM-SERIES up to 8000 mmAq (0.8 Kg/cm<sup>2</sup>)
2. Air blower delivers completely oil-free air
3. Computerized balance to lower noise level and vibration
4. Steady blow, steady capacity
5. Rotor of special design, high efficiency, low consumption
6. Solid construction, no defect
7. First degree gear, high precision, low consumption
8. Standardized processing system
9. One step process for rotor
10. Piston ring installed

## The difference between roots blowers of TWO lobes and THREE lobes

Traditional TWO lobes roots blower has high vibration and noise level, this causes short life of parts.

## THE ADVANTAGE OF THREE-LOBE ROOTS BLOWER :

1. Low reverses pressure, steady capacity, low vibration, low noise level
2. Low fluctuation of outlet pressure, make long life of bearing, gear
3. In the same RPM, THREE-lobe roots blower has low noise level, low vibration, longer life

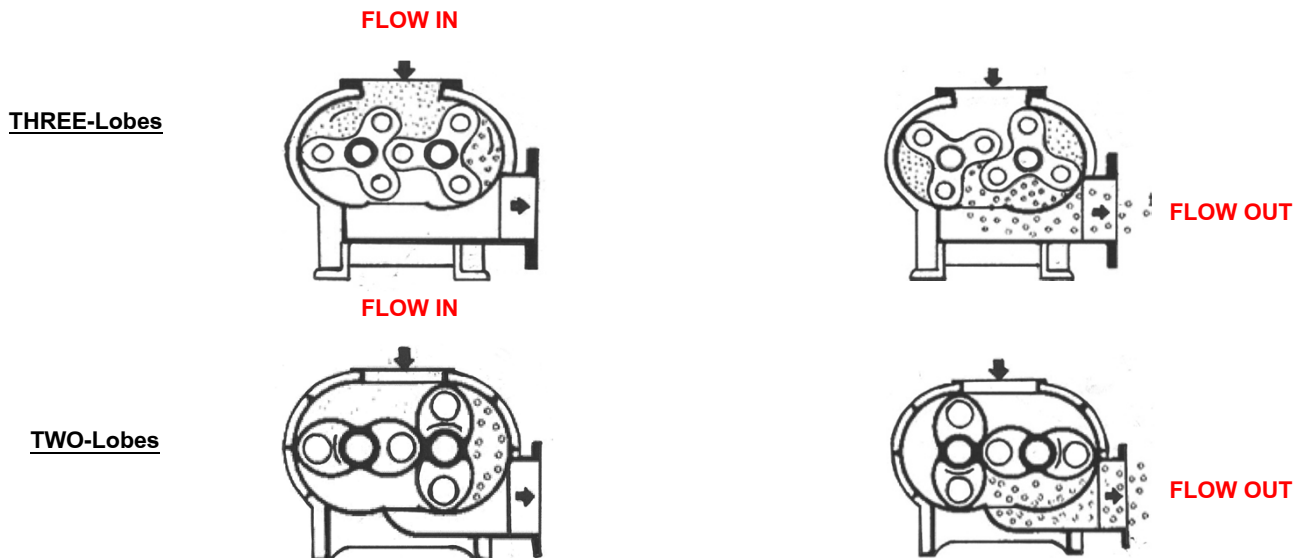

## APPLICATIONS :

1. Waste water treatment plant
2. Dust collecting after burning
3. Equipment of dust collection
4. Vacuum dehydration for dying, paper industry
5. Ventilation, desolates
6. Environment caring
7. Air exhaust, air dry
8. Air transportation
9. Gas, bulk conveyance
10. Aquarium
11. Conveyance by air
12. Liquid agitation

## UNIT CONVERSION :

### PRESSURE

PRESSURE	mbar	Pa	atm	1bt/in <sup>2</sup>	Kaf/cm <sup>2</sup>	in Hg	mmAq
1 mbar	1	10 <sup>2</sup>	9.869x10 <sup>-4</sup>	1.45x10 <sup>-2</sup>	1.02x10 <sup>-3</sup>	2.953x10 <sup>-2</sup>	10.197
1 Pa	0.01	1	9.87x10 <sup>-6</sup>	1.45x10 <sup>-4</sup>	1.02x10 <sup>-5</sup>	2.953x10 <sup>-4</sup>	0.102
1 atm	1.013x10 <sup>3</sup>	1.013x10 <sup>5</sup>	1	14.7	1.033	29.92	1.033x10 <sup>4</sup>
1 lbf/in <sup>2</sup>	68.95	6.895x10 <sup>-2</sup>	6.805x10 <sup>-2</sup>	1	7.03x10 <sup>-2</sup>	2.036	7.03x10 <sup>2</sup>
1 kgf/cm <sup>2</sup>	9.807x10 <sup>2</sup>	9.807x10 <sup>4</sup>	0.968	14.22	1	28.96	10 <sup>4</sup>
1 in Hg	33.86	3.386x10 <sup>3</sup>	3.342x10 <sup>-2</sup>	0.491	3.45x10 <sup>-2</sup>	1	3.45x10 <sup>2</sup>
1 mmAq	9.807x10 <sup>-2</sup>	9.807	9.667x10 <sup>-5</sup>	1.42x10 <sup>-3</sup>	10 <sup>-4</sup>	2.896x10 <sup>-3</sup>	1

### Pressure Conversion Formula

- 1 Pa = 0.102 mmAq
- 1 mbar = 10.197 mmAq
- 1 mmHg = 13.6 mmAq
- 1 psi = 703 mmAq
- 1 Torr = 133.3 Pa
- 1 Torr = 1.333 mbar

### CAPACITY

CAPACITY	m <sup>3</sup> /min	m <sup>3</sup> /h	l/min	ft <sup>3</sup> /min(cfm)
1 m <sup>3</sup> /min	1	60	1000	35.31
1 m <sup>3</sup> /h	0.017	1	16.67	0.589
1 l/min	0.001	0.06	1	0.035
1 ft <sup>3</sup> /min(cfm)	0.028	1.699	28.32	1

### POWER

POWER	kg-m/sec	kw	HP	PS
1 kg-m/sec	1	0.01	0.013	0.013
1 kW	101.97	1	1.341	1.360
1 HP	76.038	0.746	1	1.014
1 PS	75	0.736	0.986	1

## HOW TO SELECT THE BLOWER :

### 1. Application and conditions :

Describe the purpose of use, continuous or intermittent operation.

### 2. Capacity :

Describe whether the flow rate is at standard condition or normal condition (unless specified, the flow rate will be calculated as a flow rate under suction condition, and it is not handled as discharge flow rate i.e. at 760 mmHg, 20°C 65% RH or standard contion.)

### 3. Pressure :

Describe whether pressure is constant or variable, if variable, specify the range and the relationship between air flow rate and pressure. Describe whether pressure shows static pressure of the discharge or difference between suction and discharge pressure. State whether suction pressure is atmospheric pressure. Otherwise, specify suction and discharge pressure respectively.

### 4. Type of Gas and Specific Gravity :

Specify the following points: Type of gas and its components, content of impurities and their sizes, specific gravity, chemical properties, suggestions for materials, explosive and/or toxious nature (regarded as normal-temperature, normal-pressure air unless specified).

### 5. Gas Temperature

Roots Blowers are normally used for normal temperature at suction. If suction temperature is higher than normal temperature, please inform HEY-WEL CO.

### 6. Type of Prime Mover

When a motor is used as the prime mover, Specify the voltage, frequency and power supply condition ect.

# CONSTRUCTION

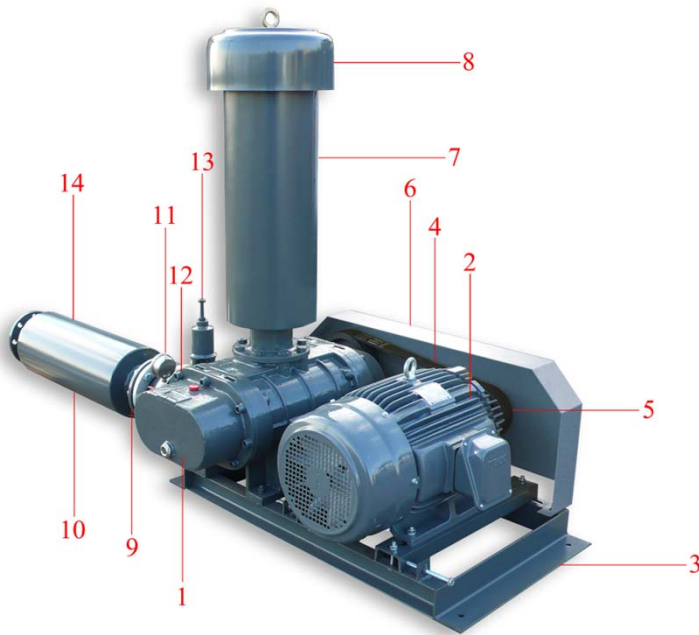

NO.	ACCESSORIES
1	Blower body
2	Motor
3	Foundation
4	Pulley
5	Driving belt
6	Belt cover
7	Inlet silencer
8	Rain cover
9	Check valve
10	Gauge pipe
11	Outlet pressure gauge
12	T-joint
13	Relief valve
14	Outlet silencer

NO.	ACCESSORIES	MATERIAL
1	Casing	FC250
2	Bearing housing	FC250
3	Oil box	FC250
4	Oil splash	SS400
5	Bearing washer	SS400
6	Framework oil seal	NBR
7	Pulley	FC250
8	Shaft	S45C
9	Drive rotor	FC250
10	V-ring	NBR
11	Bearing	SUJ2
12	Gear	FCD45
13	Lock washer	SS400
14	Lock nut	S45C
15	Gear box	FC250
16	Lubrication plug	S45C
17	Oil gauge	Assembly
18	Purge plug	S45C

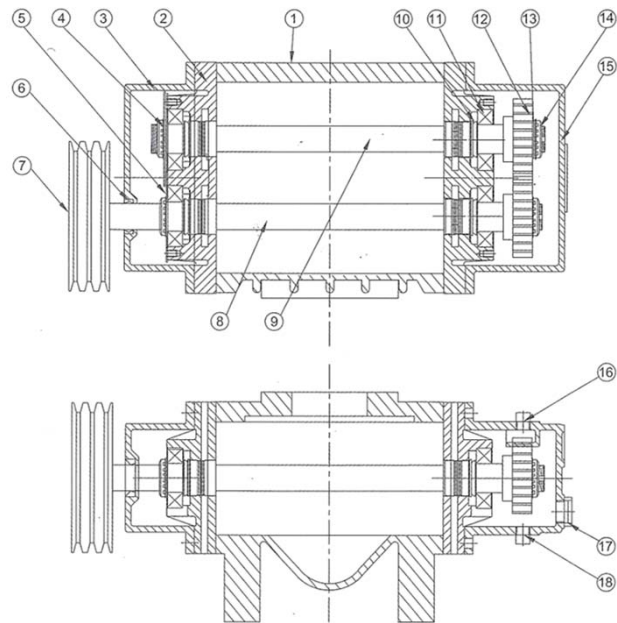

# SELECTION CHART **WML-SERIES**

NOTE : inlet flow rate  $Q_s = m^3/min$  and  $La, Kw$

Model	RPM	PERFORMANCE											
		1000mmAq		2000mmAq		3000mmAq		4000mmAq		5000mmAq		6000mmAq	
		Qs	La	Qs	La	Qs	La	Qs	La	Qs	La	Qs	La
WML-50	850	1.02	0.42	0.89	0.64	0.79	0.85	0.71	1.07	0.63	1.29	-	-
	950	1.18	0.47	1.05	0.71	0.95	0.95	0.86	1.20	0.79	1.44	-	-
	1050	1.33	0.52	1.20	0.79	1.10	1.06	1.02	1.32	0.94	1.59	-	-
	1150	1.49	0.57	1.36	0.86	1.26	1.16	1.18	1.45	1.10	1.74	-	-
	1250	1.65	0.62	1.52	0.94	1.42	1.26	1.33	1.58	1.26	1.90	1.19	2.22
	1350	1.80	0.67	1.67	1.01	1.57	1.36	1.49	1.70	1.42	2.05	1.35	2.39
	1450	1.96	0.71	1.83	1.09	1.73	1.46	1.65	1.83	1.57	2.20	1.50	2.57
	1550	2.12	0.76	1.99	1.16	1.89	1.56	1.80	1.95	1.73	2.35	1.66	2.75
	1650	2.27	0.81	2.14	1.24	2.04	1.66	1.96	2.08	1.89	2.50	1.82	2.93
WML-65	850	1.81	0.61	1.64	0.97	1.52	1.34	1.41	1.70	1.31	2.06	1.22	2.42
	950	2.07	0.68	1.91	1.09	1.78	1.49	1.67	1.90	1.57	2.30	1.48	2.71
	1050	2.34	0.75	2.17	1.20	2.04	1.65	1.93	2.10	1.83	2.55	1.75	2.99
	1150	2.60	0.82	2.43	1.32	2.30	1.81	2.19	2.30	2.09	2.79	2.01	3.28
	1250	2.86	0.90	2.69	1.43	2.56	1.96	2.45	2.50	2.35	3.03	2.27	3.56
	1350	3.12	0.97	2.95	1.54	2.82	2.12	2.71	2.70	2.62	3.27	2.53	3.85
	1450	3.38	1.04	3.21	1.66	3.08	2.28	2.97	2.90	2.88	3.51	2.79	4.13
	1550	3.64	1.11	3.47	1.77	3.34	2.43	3.23	3.10	3.14	3.76	3.05	4.42
	1650	3.90	1.18	3.73	1.89	3.61	2.59	3.50	3.30	3.40	4.00	3.31	4.70
WML-80	850	2.38	0.79	2.16	1.18	2.00	1.66	1.86	2.13	1.74	2.60	1.63	3.07
	950	2.71	0.88	2.50	1.32	2.34	1.85	2.20	2.38	2.08	2.91	1.97	3.43
	1050	3.05	0.97	2.84	1.46	2.68	2.05	2.54	2.63	2.42	3.21	2.31	3.79
	1150	3.39	1.06	3.18	1.60	3.02	2.24	2.88	2.88	2.76	3.52	2.65	4.15
	1250	3.73	1.16	3.52	1.74	3.36	2.44	3.22	3.13	3.10	3.82	2.99	4.52
	1350	4.07	1.25	3.86	1.88	3.70	2.63	3.56	3.38	3.44	4.13	3.33	4.88
	1450	4.41	1.34	4.20	2.02	4.04	2.83	3.90	3.63	3.78	4.43	3.67	5.24
	1550	4.75	1.43	4.54	2.16	4.38	3.02	4.24	3.88	4.12	4.74	4.01	5.60
	1650	5.09	1.53	4.88	2.30	4.72	3.22	4.58	4.13	4.46	5.05	4.35	5.96
WML-100	800	4.11	1.30	3.83	2.09	3.62	2.87	3.44	3.65	3.28	4.44	3.13	5.22
	900	4.71	1.47	4.43	2.35	4.22	3.23	4.03	4.11	3.87	4.99	3.73	5.87
	1000	5.31	1.63	5.03	2.61	4.82	3.59	4.63	4.57	4.47	5.55	4.33	6.52
	1100	5.91	1.79	5.63	2.87	5.42	3.95	5.23	5.02	5.07	6.10	4.93	7.18
	1200	6.51	1.96	6.23	3.13	6.01	4.31	5.83	5.48	5.67	6.65	5.53	7.83
	1300	7.11	2.12	6.83	3.39	6.61	4.66	6.43	5.94	6.27	7.21	6.13	8.48
	1400	7.71	2.28	7.43	3.65	7.21	5.02	7.03	6.39	6.87	7.76	6.73	9.13
	1500	8.31	2.45	8.03	3.91	7.81	5.38	7.63	6.85	7.47	8.32	7.32	9.79
	1600	8.91	2.61	8.63	4.18	8.41	5.74	8.23	7.31	8.07	8.87	7.92	10.44
	1650	9.21	2.69	8.93	4.31	8.71	5.92	8.53	7.54	8.37	9.15	8.22	10.76
WML-125	800	5.78	1.98	5.39	3.07	5.09	4.17	4.84	5.26	4.62	6.36	4.42	7.46
	900	6.61	2.22	6.23	3.46	5.93	4.69	5.68	5.92	5.46	7.15	5.26	8.39
	1000	7.45	2.47	7.07	3.84	6.77	5.21	6.52	6.58	6.30	7.95	6.10	9.32
	1100	8.29	2.72	7.90	4.22	7.61	5.73	7.36	7.24	7.14	8.74	6.94	10.25
	1200	9.13	2.96	8.74	4.61	8.45	6.25	8.20	7.90	7.98	9.54	7.78	11.18
	1300	9.97	3.21	9.58	4.99	9.29	6.77	9.03	8.55	8.81	10.33	8.61	12.12
	1400	10.81	3.46	10.42	5.37	10.12	7.29	9.87	9.21	9.65	11.13	9.45	13.05
	1500	11.65	0.70	11.26	5.76	10.96	7.81	10.71	9.87	10.49	11.92	10.29	13.98
	1600	12.49	3.95	12.10	6.14	11.80	8.33	11.55	10.53	11.33	12.72	11.13	14.91
	1650	12.91	4.07	12.52	6.33	12.22	8.60	11.97	10.86	11.75	13.12	11.55	15.38

# SELECTION CHART **WML-SERIES**

NOTE : inlet flow rate  $Q_s = m^3/min$  and  $La, Kw$

Model	RPM	PERFORMANCE											
		1000mmAq		2000mmAq		3000mmAq		4000mmAq		5000mmAq		6000mmAq	
		Qs	La	Qs	La	Qs	La	Qs	La	Qs	La	Qs	La
WML-150	780	12.64	3.82	12.08	6.11	11.64	8.39	11.27	10.68	10.95	12.97	10.66	15.26
	830	13.54	4.06	12.97	6.50	12.54	8.93	12.17	11.37	11.85	13.81	11.55	16.24
	880	14.44	4.30	13.87	6.89	13.44	9.47	13.07	12.05	12.75	14.64	12.45	17.22
	930	15.34	4.55	14.77	7.28	14.34	10.01	13.97	12.74	13.64	15.47	13.35	18.20
	990	16.42	4.84	15.85	7.75	15.41	10.65	15.05	13.56	14.72	16.47	14.43	19.37
	1050	17.50	5.14	16.93	8.22	16.49	11.30	16.12	14.38	15.80	17.46	15.51	20.55
	1110	18.57	5.43	18.01	8.69	17.57	11.95	17.20	15.20	16.88	18.46	16.59	21.72
	1180	19.83	5.77	19.26	9.24	18.83	12.70	18.46	16.16	18.14	19.63	17.84	23.09
	1250	21.09	6.11	20.52	9.78	20.09	13.45	19.72	17.12	19.39	20.79	19.10	24.46
	1320	22.35	6.46	21.78	10.33	21.34	14.21	20.98	18.08	20.65	21.96	20.36	25.83
	1390	23.61	6.80	23.04	10.88	22.60	14.96	22.23	19.04	21.91	23.12	21.62	27.20
	1470	25.04	7.19	24.48	11.51	24.04	15.82	23.67	20.14	23.35	24.45	23.06	28.76
	1560	26.66	7.63	26.09	12.21	25.66	16.79	25.29	21.37	24.97	25.95	24.67	30.53
	1650	28.28	8.07	27.71	12.91	27.27	17.76	26.91	22.60	26.58	27.44	26.29	32.29
WML-200	780	23.65	7.06	22.70	9.52	21.97	13.76	21.36	17.99	20.81	22.23	20.32	26.47
	830	25.31	7.52	24.36	10.13	23.63	14.64	23.02	19.15	22.48	23.66	21.99	28.17
	880	26.98	7.97	26.03	10.74	25.30	15.52	24.68	20.30	24.14	25.08	23.65	29.86
	930	28.64	8.42	27.69	11.35	26.96	16.40	26.34	21.45	25.80	26.51	25.31	31.56
	990	30.63	8.96	29.68	12.08	28.95	17.46	28.34	22.84	27.80	28.22	27.31	33.60
	1050	32.63	9.51	31.68	12.81	30.95	18.52	30.34	24.22	29.79	29.93	29.30	35.63
	1110	34.63	10.05	33.68	13.55	32.95	19.58	32.33	25.61	31.79	31.64	31.30	37.67
	1180	36.95	10.68	36.00	14.40	35.27	20.81	34.66	27.22	34.12	33.63	33.63	40.04
	1250	39.28	11.32	38.33	15.26	37.60	22.05	36.99	28.84	36.45	35.63	35.96	42.42
	1320	41.61	11.95	40.66	16.11	39.93	23.28	39.32	30.45	38.77	37.62	38.28	44.79
	1390	43.94	12.59	42.99	16.96	42.26	24.52	41.64	32.07	41.10	39.62	40.61	47.17
	1470	46.60	13.31	45.65	17.94	44.92	25.93	44.31	33.91	43.76	41.90	43.27	49.88
	1560	49.59	14.12	48.64	19.04	47.91	27.51	47.30	35.99	46.76	44.46	46.27	52.94
	1650	52.59	14.94	51.64	20.14	50.91	29.10	50.29	38.05	49.75	47.03	49.26	55.99
WML-250	830	37.22	10.80	36.20	17.28	35.42	23.75	34.77	30.23	34.19	36.71	33.67	43.19
	880	39.61	11.45	38.59	18.32	37.81	25.19	37.16	32.05	36.58	38.92	36.06	45.79
	930	42.00	12.10	40.98	19.36	40.20	26.62	39.55	33.88	38.97	41.13	38.45	48.39
	990	44.86	12.88	43.85	20.61	43.07	28.33	42.41	36.06	41.84	43.79	41.31	51.52
	1050	47.73	13.66	46.72	21.86	45.94	30.05	45.28	38.25	44.70	46.44	44.18	54.64
	1110	50.60	14.44	49.58	23.10	48.81	31.77	48.15	40.43	47.57	49.10	47.50	57.76
	1180	53.94	15.35	52.93	24.56	52.15	33.77	51.49	42.98	50.92	52.19	50.39	61.40
	1250	57.29	16.26	56.27	26.02	55.50	35.77	54.84	45.53	54.26	55.29	53.74	65.05
	1320	60.63	17.17	59.62	27.48	58.84	37.78	58.18	48.08	57.61	58.38	57.08	68.69
	1390	63.98	18.08	62.96	28.93	62.19	39.78	61.53	50.63	60.95	61.48	60.43	72.33
1470	67.80	19.12	66.79	30.60	66.01	42.07	65.35	53.55	64.78	65.02	64.25	76.49	
WML-300	620	48.68	14.34	47.02	22.94	45.75	31.55	44.68	40.15	43.73	48.75	42.88	57.36
	660	52.07	15.26	50.42	24.42	49.15	33.58	48.08	42.74	47.13	51.90	46.28	61.06
	700	55.47	16.19	53.82	25.90	52.55	35.62	51.47	45.33	50.53	55.04	49.68	64.76
	740	58.87	17.11	57.21	27.38	55.94	37.65	54.87	47.92	53.93	58.19	53.08	68.46
	780	62.27	18.04	60.61	28.86	59.34	39.69	58.27	50.51	57.33	61.33	56.47	72.16
	830	66.52	19.20	64.86	30.71	63.59	42.23	62.52	53.75	61.57	65.26	60.72	76.78
	880	70.76	20.35	69.11	32.56	67.84	44.77	66.77	56.99	65.82	69.20	64.97	81.41
	930	75.01	21.51	73.36	34.41	72.09	47.32	71.01	60.22	70.07	73.13	69.22	86.03
	990	80.11	22.90	78.45	36.63	77.18	50.37	76.11	64.11	75.17	77.85	74.31	91.58
	1050	85.21	24.28	83.55	38.85	82.28	53.42	81.21	67.99	80.27	82.56	79.41	97.13
	1110	90.30	25.67	88.65	41.07	87.38	56.48	86.31	71.88	85.36	87.28	84.51	102.68
	1180	96.25	27.29	94.60	43.66	93.32	60.04	92.25	76.41	91.31	92.79	90.46	109.16
	1250	102.20	28.91	100.54	46.25	99.27	63.60	98.20	80.95	97.26	98.29	96.40	115.64
	1320	108.15	30.53	106.49	48.84	105.22	67.16	104.15	85.48	103.20	103.79	102.35	122.11
	1390	114.09	32.15	112.44	51.43	111.17	70.72	110.09	90.01	109.15	109.30	108.30	128.59
1470	120.89	34.00	119.23	54.40	117.96	74.79	116.89	95.19	115.95	115.59	115.09	135.99	

# SELECTION CHART **WM-SERIES**

NOTE : inlet flow rate  $Q_s = m^3/min$  and  $La, Kw$

Model	RPM	PERFORMANCE															
		1000mmAq		2000mmAq		3000mmAq		4000mmAq		5000mmAq		6000mmAq		7000mmAq		8000mmAq	
		Qs	La	Qs	La	Qs	La	Qs	La	Qs	La	Qs	La	Qs	La	Qs	La
WM-50	850	1.81	0.61	1.64	0.97	1.52	1.34	1.41	1.70	1.31	2.06	1.22	2.42	1.14	2.79	1.07	3.15
	950	2.07	0.68	1.91	1.09	1.78	1.49	1.67	1.90	1.57	2.30	1.48	2.71	1.40	3.11	1.33	3.52
	1050	2.34	0.75	2.17	1.20	2.04	1.65	1.93	2.10	1.83	2.55	1.75	2.99	1.67	3.44	1.59	3.89
	1150	2.60	0.82	2.43	1.32	2.30	1.81	2.19	2.30	2.09	2.79	2.01	3.28	1.93	3.77	1.85	4.26
	1250	2.86	0.90	2.69	1.43	2.56	1.96	2.45	2.50	2.35	3.03	2.27	3.56	2.19	4.10	2.11	4.63
	1350	3.12	0.97	2.95	1.54	2.82	2.12	2.71	2.70	2.62	3.27	2.53	3.85	2.45	4.42	2.37	5.00
	1450	3.38	1.04	3.21	1.66	3.08	2.28	2.97	2.90	2.88	3.51	2.79	4.13	2.71	4.75	2.64	5.37
	1550	3.64	1.11	3.47	1.77	3.34	2.43	3.23	3.10	3.14	3.76	3.05	4.42	2.97	5.08	2.90	5.74
	1650	3.90	1.18	3.73	1.89	3.61	2.59	3.50	3.30	3.40	4.00	3.31	4.70	3.23	5.41	3.16	6.11
WM-65	850	2.38	0.79	2.16	1.18	2.00	1.66	1.86	2.13	1.74	2.60	1.63	3.07	1.53	3.54	1.44	4.01
	950	2.71	0.88	2.50	1.32	2.34	1.85	2.20	2.38	2.08	2.91	1.97	3.43	1.87	3.96	1.78	4.49
	1050	3.05	0.97	2.84	1.46	2.68	2.05	2.54	2.63	2.42	3.21	2.31	3.79	2.21	4.38	2.12	4.96
	1150	3.39	1.06	3.18	1.60	3.02	2.24	2.88	2.88	2.76	3.52	2.65	4.15	2.55	4.79	2.46	5.43
	1250	3.73	1.16	3.52	1.74	3.36	2.44	3.22	3.13	3.10	3.82	2.99	4.52	2.89	5.21	2.80	5.90
	1350	4.07	1.25	3.86	1.88	3.70	2.63	3.56	3.38	3.44	4.13	3.33	4.88	3.23	5.63	3.14	6.38
	1450	4.41	1.34	4.20	2.02	4.04	2.83	3.90	3.63	3.78	4.43	3.67	5.24	3.57	6.04	3.48	6.85
	1550	4.75	1.43	4.54	2.16	4.38	3.02	4.24	3.88	4.12	4.74	4.01	5.60	3.91	6.46	3.82	7.32
	1650	5.09	1.53	4.88	2.30	4.72	3.22	4.58	4.13	4.46	5.05	4.35	5.96	4.25	6.88	4.16	7.79
WM-80	800	4.11	1.30	3.83	2.09	3.62	2.87	3.44	3.65	3.28	4.44	3.13	5.22	3.00	6.00	2.87	6.78
	900	4.71	1.47	4.43	2.35	4.22	3.23	4.03	4.11	3.87	4.99	3.73	5.87	3.60	6.75	3.47	7.63
	1000	5.31	1.63	5.03	2.61	4.82	3.59	4.63	4.57	4.47	5.55	4.33	6.52	4.20	7.50	4.07	8.48
	1100	5.91	1.79	5.63	2.87	5.42	3.95	5.23	5.02	5.07	6.10	4.93	7.18	4.79	8.25	4.67	9.33
	1200	6.51	1.96	6.23	3.13	6.01	4.31	5.83	5.48	5.67	6.65	5.53	7.83	5.39	9.00	5.27	10.18
	1300	7.11	2.12	6.83	3.39	6.61	4.66	6.43	5.94	6.27	7.21	6.13	8.48	5.99	9.75	5.87	11.03
	1400	7.71	2.28	7.43	3.65	7.21	5.02	7.03	6.39	6.87	7.76	6.73	9.13	6.59	10.50	6.47	11.87
	1500	8.31	2.45	8.03	3.91	7.81	5.38	7.63	6.85	7.47	8.32	7.32	9.79	7.19	11.25	7.07	12.72
	1600	8.91	2.61	8.63	4.18	8.41	5.74	8.23	7.31	8.07	8.87	7.92	10.44	7.79	12.00	7.67	13.57
1650	9.21	2.69	8.93	4.31	8.71	5.92	8.53	7.54	8.37	9.15	8.22	10.76	8.09	12.38	7.97	13.99	
WM-100	800	5.78	1.98	5.39	3.07	5.09	4.17	4.84	5.26	4.62	6.36	4.42	7.46	4.24	8.55	4.07	9.65
	900	6.61	2.22	6.23	3.46	5.93	4.69	5.68	5.92	5.46	7.15	5.26	8.39	5.08	9.62	4.91	10.85
	1000	7.45	2.47	7.07	3.84	6.77	5.21	6.52	6.58	6.30	7.95	6.10	9.32	5.91	10.69	5.74	12.06
	1100	8.29	2.72	7.90	4.22	7.61	5.73	7.36	7.24	7.14	8.74	6.94	10.25	6.75	11.76	6.58	13.27
	1200	9.13	2.96	8.74	4.61	8.45	6.25	8.20	7.90	7.98	9.54	7.78	11.18	7.59	12.83	7.42	14.47
	1300	9.97	3.21	9.58	4.99	9.29	6.77	9.03	8.55	8.81	10.33	8.61	12.12	8.43	13.90	8.26	15.68
	1400	10.81	3.46	10.42	5.37	10.12	7.29	9.87	9.21	9.65	11.13	9.45	13.05	9.27	14.97	9.10	16.88
	1500	11.65	3.70	11.26	5.76	10.96	7.81	10.71	9.87	10.49	11.92	10.29	13.98	10.11	16.03	9.94	18.09
	1600	12.49	3.95	12.10	6.14	11.80	8.33	11.55	10.53	11.33	12.72	11.13	14.91	10.95	17.10	10.78	19.30
1650	12.91	4.07	12.52	6.33	12.22	8.60	11.97	10.86	11.75	13.12	11.55	15.38	11.37	17.64	11.20	19.90	
WM-125	780	12.64	3.82	12.08	6.11	11.64	8.39	11.27	10.68	10.95	12.97	10.66	15.26	10.39	17.55	10.14	19.84
	830	13.54	4.06	12.97	6.50	12.54	8.93	12.17	11.37	11.85	13.81	11.55	16.24	11.28	18.68	11.03	21.11
	880	14.44	4.30	13.87	6.89	13.44	9.47	13.07	12.05	12.75	14.64	12.45	17.22	12.18	19.80	11.93	22.39
	930	15.34	4.55	14.77	7.28	14.34	10.01	13.97	12.74	13.64	15.47	13.35	18.20	13.08	20.93	12.83	23.66
	990	16.42	4.84	15.85	7.75	15.41	10.65	15.05	13.56	14.72	16.47	14.43	19.37	14.16	22.28	13.91	25.18
	1050	17.50	5.14	16.93	8.22	16.49	11.30	16.12	14.38	15.80	17.46	15.51	20.55	15.24	23.63	14.99	26.71
	1110	18.57	5.43	18.01	8.69	17.57	11.95	17.20	15.20	16.88	18.46	16.59	21.72	16.32	24.98	16.07	28.24
	1180	19.83	5.77	19.26	9.24	18.83	12.70	18.46	16.16	18.14	19.63	17.84	23.09	17.57	26.55	17.32	30.02
	1250	21.09	6.11	20.52	9.78	20.09	13.45	19.72	17.12	19.39	20.79	19.10	24.46	18.83	28.13	18.58	31.80
	1320	22.35	6.46	21.78	10.33	21.34	14.21	20.98	18.08	20.65	21.96	20.36	25.83	20.09	29.70	19.84	33.58
	1390	23.61	6.80	23.04	10.88	22.60	14.96	22.23	19.04	21.91	23.12	21.62	27.20	21.35	31.28	21.10	35.36
	1470	25.04	7.19	24.48	11.51	24.04	15.82	23.67	20.14	23.35	24.45	23.06	28.76	22.79	33.08	22.53	37.39
	1560	26.66	7.63	26.09	12.21	25.66	16.79	25.29	21.37	24.97	25.95	24.67	30.53	24.40	35.10	24.17	39.68
1650	28.28	8.07	27.71	12.91	27.27	17.76	26.91	22.60	26.58	27.44	26.29	32.29	26.02	37.13	25.77	41.97	

# SELECTION CHART WM-SERIES

NOTE : inlet flow rate  $Q_s = m^3/min$  and  $La, Kw$

Model	RPM	PERFORMANCE															
		1000mmAq		2000mmAq		3000mmAq		4000mmAq		5000mmAq		6000mmAq		7000mmAq		8000mmAq	
		Qs	La	Qs	La	Qs	La	Qs	La	Qs	La	Qs	La	Qs	La	Qs	La
WM-150	780	16.35	4.92	15.64	7.87	15.09	10.82	14.62	13.78	14.22	16.73	13.85	19.68	13.51	22.63	13.20	25.59
	830	17.51	5.24	16.79	8.38	16.25	11.52	15.78	14.66	15.38	17.80	15.01	20.94	14.67	24.08	14.35	27.23
	880	18.67	5.55	17.95	8.88	17.40	12.21	16.94	15.54	16.53	18.87	16.17	22.20	15.83	25.53	15.51	28.87
	930	19.83	5.87	19.11	9.39	18.56	12.91	18.10	16.43	17.69	19.95	17.33	23.47	16.99	26.99	16.67	30.51
	990	21.22	6.24	20.50	9.99	19.95	13.74	19.49	17.49	19.08	21.23	18.72	24.98	18.38	28.73	18.06	32.47
	1050	22.61	6.62	21.89	10.60	21.34	14.57	20.88	18.55	20.47	22.52	20.11	26.49	19.77	30.47	19.45	34.44
	1110	24.00	7.00	23.28	11.20	22.73	15.40	22.27	19.61	21.86	23.81	21.50	28.01	21.16	32.21	20.84	36.41
	1180	25.62	7.44	24.90	11.91	24.36	16.38	23.89	20.84	23.49	25.31	23.12	29.77	22.78	34.24	22.46	38.71
	1250	27.24	7.89	26.53	12.62	25.98	17.35	25.52	22.08	25.11	26.81	24.74	31.54	24.40	36.27	24.09	41.00
	1320	28.86	8.33	28.15	13.32	27.60	18.32	27.14	23.31	26.73	28.31	26.36	33.31	26.02	38.30	25.71	43.30
	1390	30.48	8.77	29.77	14.03	29.22	19.29	28.76	24.55	28.35	29.81	27.98	35.07	27.65	40.33	27.33	45.59
	1470	32.34	9.27	31.62	14.84	31.08	20.40	30.61	25.96	30.21	31.53	29.84	37.09	29.50	42.65	29.18	48.22
	1560	34.42	9.84	33.71	15.74	33.16	21.65	32.70	27.55	32.29	33.46	31.92	39.36	31.59	45.27	31.27	51.17
	1650	36.51	10.41	35.80	16.65	35.25	22.90	34.78	29.14	34.38	35.39	34.01	41.63	33.67	47.88	33.36	54.12
WM-200	880	39.61	11.45	38.59	18.32	37.81	25.19	37.16	32.05	36.58	38.92	36.06	45.79	35.58	52.66	35.13	59.53
	930	42.00	12.10	40.98	19.36	40.20	26.62	39.55	33.88	38.97	41.13	38.45	48.39	37.97	55.65	37.52	62.91
	990	44.86	12.88	43.85	20.61	43.07	28.33	42.41	36.06	41.84	43.79	41.31	51.52	40.83	59.24	40.39	66.97
	1050	47.73	13.66	46.72	21.86	45.94	30.05	45.28	38.25	44.70	46.44	44.18	54.64	43.70	62.83	43.25	71.03
	1110	50.60	14.44	49.58	23.10	48.81	31.77	48.15	40.43	47.57	49.10	47.05	57.76	46.57	66.42	46.12	75.09
	1180	53.94	15.35	52.93	24.56	52.15	33.77	51.49	42.98	50.92	52.19	50.39	61.40	49.91	70.61	49.47	79.82
	1250	57.29	16.26	56.27	26.02	55.50	35.77	54.84	45.53	54.26	55.29	53.74	65.05	53.26	74.80	52.81	84.56
	1320	60.63	17.17	59.62	27.48	58.84	37.78	58.18	48.08	57.61	58.38	57.08	68.69	56.60	78.99	56.16	89.29
	1390	63.98	18.08	62.96	28.93	62.19	39.78	61.53	50.63	60.95	61.48	60.43	72.33	59.95	83.18	59.50	94.03
1470	67.80	19.12	66.79	30.60	66.01	42.07	65.35	53.55	64.78	65.02	64.25	76.49	63.77	87.97	63.33	99.44	
WM-250	830	50.02	14.40	48.83	23.03	47.92	31.67	47.15	40.31	46.48	48.95	45.87	57.59	45.30	66.22	44.78	74.86
	880	53.21	15.26	52.02	24.42	51.11	33.58	50.34	42.74	49.66	51.90	49.05	61.06	48.49	70.21	47.97	79.37
	930	56.39	16.13	55.20	25.81	54.29	35.49	53.53	45.17	52.85	54.85	52.24	64.52	51.68	74.20	51.15	83.88
	990	60.21	17.17	59.03	27.48	58.12	37.78	57.35	48.08	56.67	58.38	56.06	68.69	55.50	78.99	54.97	89.29
	1050	64.04	18.21	62.85	29.14	61.94	40.07	61.17	51.00	60.50	61.92	59.88	72.85	59.32	83.78	58.80	94.71
	1110	67.86	19.25	66.67	30.81	65.76	42.36	64.99	53.91	64.32	65.46	63.71	77.01	63.14	88.57	62.62	100.12
	1180	72.32	20.47	71.13	32.75	70.22	45.03	69.46	57.31	68.78	69.59	68.17	81.87	67.60	94.15	67.08	106.43
	1250	76.78	21.68	75.59	34.69	74.68	47.70	73.92	60.71	73.24	73.72	72.63	86.73	72.06	99.74	71.54	112.75
	1320	81.24	22.90	80.05	36.63	79.14	50.37	78.38	64.11	77.70	77.85	77.09	91.58	76.53	105.32	76.00	119.06
	1390	85.70	24.11	84.51	38.58	83.60	53.04	82.84	67.51	82.16	81.97	81.55	96.44	80.99	110.91	80.46	125.37
1470	90.80	25.50	89.61	40.80	88.70	56.10	87.93	71.39	87.26	86.69	86.65	101.99	86.08	117.29	85.56	132.59	
WM-300	800	101.28	29.11	98.93	46.58	97.12	64.05	95.60	81.52	94.26	98.99	93.05	116.46	91.94	133.92	90.90	151.39
	900	114.64	32.75	112.30	52.40	110.49	72.06	108.97	91.71	107.63	111.36	106.42	131.01	105.31	150.66	104.27	170.32
	1000	128.01	36.39	125.66	58.23	123.86	80.06	122.34	101.90	121.00	123.73	119.79	145.57	118.68	167.40	117.64	189.24
	1100	141.38	40.03	139.03	64.05	137.23	88.07	135.71	112.09	134.37	136.11	133.16	160.13	132.05	184.14	131.01	208.16
	1200	154.75	43.67	152.40	69.87	150.60	96.08	149.08	122.28	147.74	148.48	146.53	174.68	145.41	200.89	144.38	227.09
	1300	168.12	47.31	165.77	75.70	163.97	104.08	162.45	132.47	161.11	160.85	159.90	189.24	158.78	217.63	157.75	246.01
	1400	181.49	50.95	179.14	81.52	177.34	112.09	175.82	142.66	174.48	173.23	173.27	203.80	172.15	234.37	171.12	264.94



## WM SERIES OVERALL DIMENSION

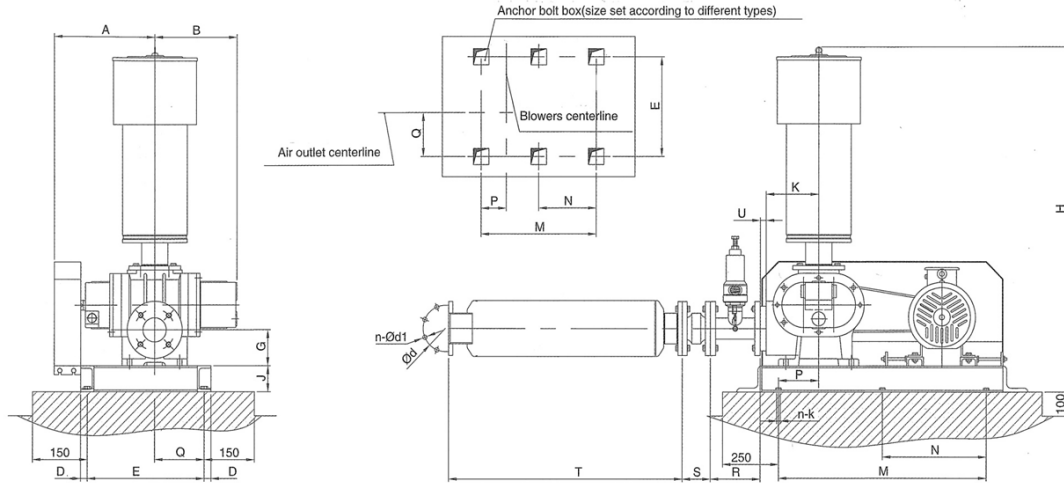

UNIT(MM.)

Model	A	B	D	E	G	H	J	K	M	N	P	Q	R	S	T	U	d	n-Ød1	n-k
WM-50	300	278	20	412	103.5	921	80	140	520	-	93	211	150	105	595	18	125	4-Ø18	4-M12x160
WM-65	323	308	20	412	104	924	80	152	520	-	93	188.5	150	115	595	18	145	4-Ø18	4-M12x160
WM-80	383	340	20	482	106.5	1241	80	180	700	-	80	238	180	135	795	22	160	8-Ø18	4-M12x160
WM-100	426	390	20	482	110	1245	80	180	700	-	98	195	180	150	795	22	180	8-Ø18	4-M16x220
WM-125	505	430.5	24	602	157.5	1835	100	262	950	-	182	271	250	165	1260	22	210	8-Ø18	4-M16x220
WM-150	564	485.5	24	602	163.5	1860	100	250	950	-	182	212	250	180	1260	22	240	8-Ø23	4-M16x220
WM-200	565	515	30	940	194	2285	160	345	1300	650	310	580	250	210	1645	25	295	8-Ø23	6-M20x300
WM-250	695	590	30	940	216	2520	160	356	1400	700	270	490	250	230	1750	38	350	12-Ø23	6-M20x300
WM-300	840	627.5	35	1030	300	2955	250	510	2000	1000	321	487	300	250	1850	38	400	12-Ø23	6-M20x300

\*\*Weight of blower and standard accessories not including motor.\*\*

## WML SERIES OVERALL DIMENSION

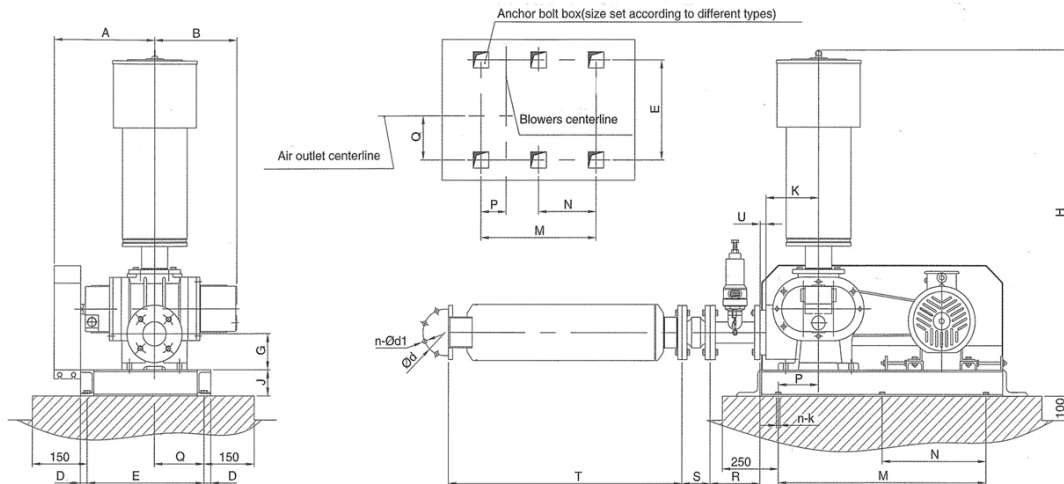

UNIT(MM.)

Model	A	B	D	E	G	H	J	K	M	N	P	Q	R	S	T	U	d	n-Ød1	n-k
WML-50	235	202	20	412	104	791	56	140	520	-	98	95	150	105	595	18	125	4-Ø18	4-M12x160
WML-65	300	245	20	412	107	971	80	140	520	-	93	211	150	115	595	18	145	4-Ø18	4-M12x160
WML-80	323	273	20	412	110	980	80	160	520	-	93	188.5	180	135	795	18	160	8-Ø18	4-M12x160
WML-100	383	300	20	482	115	1300	80	180	700	-	80	238	180	150	795	18	180	8-Ø18	4-M16x220
WML-125	426	350	20	482	145	1330	80	180	700	-	98	195	250	165	1260	18	210	8-Ø18	4-M16x220
WML-150	505	430	24	602	163.5	1910	100	250	950	-	182	271	250	180	1260	18	240	8-Ø23	4-M16x220
WML-200	605	508	24	602	185	2020	100	290	950	-	182	212	250	190	1645	23	295	8-Ø23	6-M20x300
WML-250	565	551	30	940	214	2395	160	345	1300	650	310	580	250	230	1750	38	350	12-Ø23	6-M20x300
WML-300	805	726	30	940	255	2710	160	360	1500	750	248	470	300	250	1850	38	400	12-Ø23	6-M20x300

\*\*Weight of blower and standard accessories not including motor.\*\*

# WM - WML SERIES

## DIMENSION OF ACCESSORIES (UNIT/MM.)

### Suction Silencer

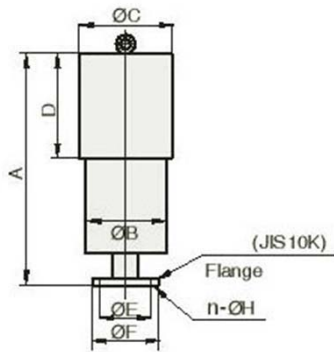

TYPE	A	B	C	D	E	F	n-ØH	Fitting Model
SS50	550	133	150	220	120	155	4-Ø19	WM-50/WML-50
SS65	550	159	190	280	140	175	4-Ø19	WM-65/WML-65
SS80	820	219	245	280	150	185	8-Ø19	WM-80/WML-80
SS100	820	245	273	330	175	210	8-Ø19	WM-100/WML-100
SS125	1310	273	310	350	210	250	8-Ø23	WM-125/WML-125
SS150	1310	299	340	370	240	280	8-Ø23	WM-150/WML-150
SS200	1500	330	380	370	290	330	12-Ø23	WM-200/WML-200
SS250	1700	400	480	550	355	400	12-Ø25	WM-250/WML-250
SS300	1825	500	600	650	400	445	16-Ø25	WM-300/WML-300

### Discharge Silencer

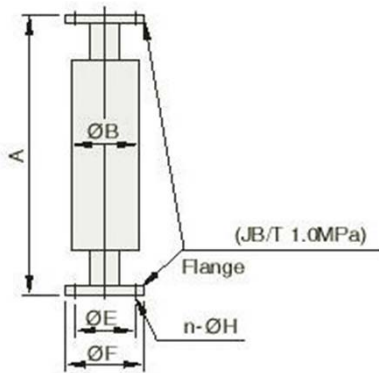

TYPE	A	B	E	F	n-ØH	Fitting Model
DS50	595	159	125	160	4-Ø18	WM-50/WML-50
DS65	595	159	145	180	4-Ø18	WM-65/WML-65
DS80	795	219	160	195	8-Ø18	WM-80/WML-80
DS100	795	219	180	215	8-Ø18	WM-100/WML-100
DS125	1260	290	210	245	8-Ø18	WM-125/WML-125
DS150	1260	290	240	280	8-Ø23	WM-150/WML-150
DS200	1645	356	295	335	8-Ø23	WM-200/WML-200
DS250	1750	405	350	390	12-Ø23	WM-250/WML-250
DS300	1850	484	400	440	12-Ø23	WM-300/WML-300

### " T "-Joint

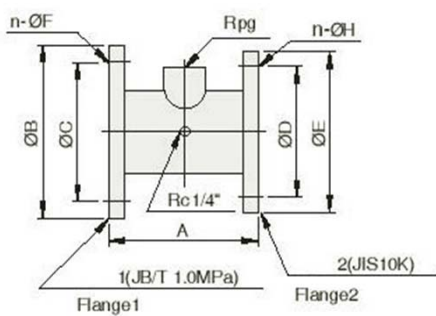

TYPE	A	B	C	n-ØF	E	D	n-ØH	g	Fitting Model
HJ50	150	160	125	4-Ø18	155	120	4-Ø19	1 1/4"	WM-50/WML-50
HJ65	150	180	145	4-Ø18	175	140	4-Ø19	1 1/4"	WM-65/WML-65
HJ80	180	195	160	8-Ø18	185	150	8-Ø19	1 1/4"	WM-80/WML-80
HJ100	180	215	180	8-Ø18	210	175	8-Ø19	2"	WM-100/WML-100
HJ125	250	245	210	8-Ø18	250	210	8-Ø23	2"	WM-125/WML-125
HJ150	250	280	240	8-Ø23	280	240	8-Ø23	2"	WM-150/WML-150
HJ200	250	335	295	8-Ø23	330	290	12-Ø23	3"	WM-200/WML-200
HJ250	250	390	350	12-Ø23	400	355	12-Ø25	3"	WM-250/WML-250
HJ300	300	440	400	12-Ø23	445	400	16-Ø25	DN125	WM-300/WML-300

# WM - WML SERIES

## Relief Valve

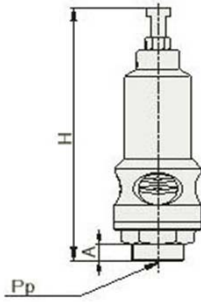

TYPE	A	H	Fitting Model
SV 1/4"	19	145	WM-50,65,80/WML-50,65,80
SV 2"	24	185	WM-100,125,150/WML-100,125,150
SV 3"	30	230	WM-200,250/WML-200,250
SV 125	90	490	WM-300/WML-300

## Check Valve

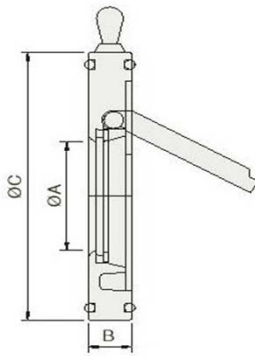

TYPE	A	B	C	Fitting Model
DCV-50	37	18	102.5	WM-50/WML-50
DCV-65	45	18	122.5	WM-65/WML-65
DCV-80	52	22	132	WM-80/WML-80
DCV-100	65	22	158	WM-100/WML-100
DCV-125	90	22	190	WM-125/WML-125
DCV-150	115	22	215	WM-150/WML-150
DCV-200	160	25	268	WM-200/WML-200
DCV-250	180	38	325	WM-250/WML-250
DCV-300	213	38	375	WM-300/WML-300

## Flexible connector

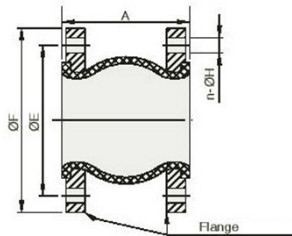

TYPE	A	E	F	n-ØH	Fitting Model
KXT50	105	125	165	4-Ø18	WM-50/WML-50
KXT65	115	145	185	4-Ø18	WM-65/WML-65
KXT80	135	160	200	8-Ø18	WM-80/WML-80
KXT100	150	180	220	8-Ø18	WM-100/WML-100
KXT125	165	210	250	8-Ø18	WM-125/WML-125
KXT150	180	240	285	8-Ø22	WM-150/WML-150
KXT200	190	295	340	8-Ø22	WM-200/WML-200
KXT250	230	350	395	12-Ø22	WM-250/WML-250
KXT300	250	400	445	12-Ø22	WM-300/WML-300

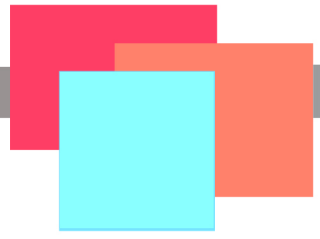

DISTRIBUTOR

