

TripSaver[®] II

Cutout-Mounted Recloser



Save money and increase reliability.

Reduce momentary outages and truck rolls with
S&C's self-powered, electronically controlled
single-phase recloser.

S&C's TripSaver II Cutout-Mounted Recloser

A better solution for overhead lateral circuit protection at 15 kV and 25 kV

Utilities need a better option for their fault-protection strategy.

More than 80% of overhead distribution faults are temporary. A utility's lateral-protection strategy could either be causing more momentary outages or more truck rolls.

With all the laterals on a utility's system, truck-roll costs can add up to millions of dollars every year.

A TRUCK ROLL CAN EXCEED \$1,000

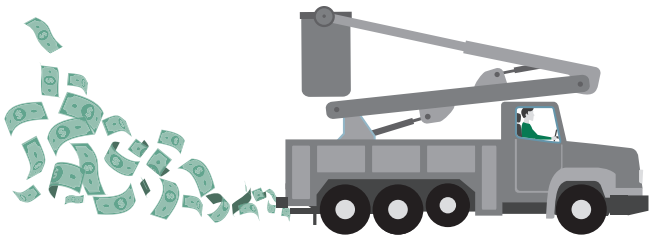

Over the years, utilities have dealt with lateral protection a couple of ways.

Some utilities use a "fuse-blowing" philosophy: The substation feeder breaker is properly coordinated with the lateral fuse so the fuse, not the breaker, will clear any downstream fault within its rating, but not the breaker. Customers on the lateral experience sustained service interruption—even for a transient fault, as shown in Figure 1. And the utility must deal with the high cost of service calls to replace lateral fuses.

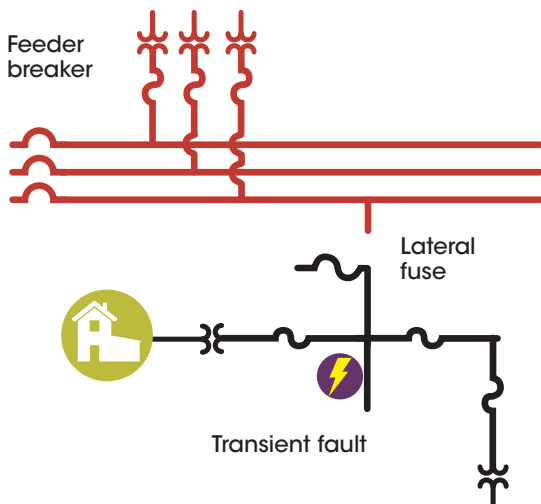

Figure 1. "Fuse-blowing" philosophy.

Other utilities use a "fuse-saving" philosophy: The first trip of the substation feeder breaker is intentionally coordinated so the breaker operates faster than the lateral fuse to clear a fault downstream of the lateral fuse. The second trip of the breaker is slower so if the fault is still present, the lateral fuse will operate to clear it. All customers on the feeder experience a momentary interruption for all faults, as shown in Figure 2.

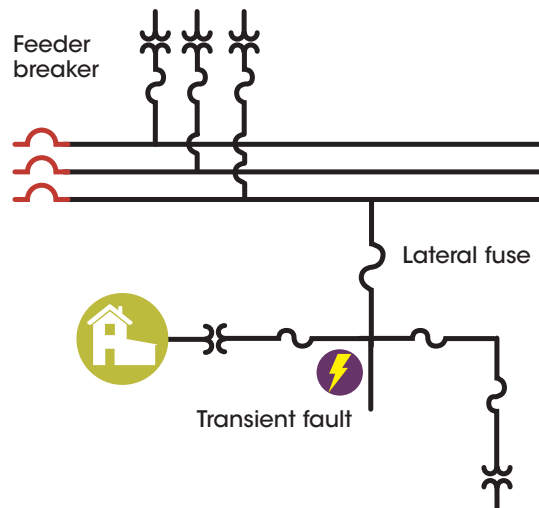

Figure 2. "Fuse-saving" philosophy.

TripSaver II reclosers combine the best of fuse-saving and fuse-blowing and improve reliability.

S&C's TripSaver II Cutout-Mounted Recloser keeps the power on and avoids truck rolls. A lateral-reclosing strategy ensures transient faults do not result in a sustained interruption and other laterals on the feeder are not "blinked."

Power can be restored automatically for transient faults, avoiding a sustained outage or the need for a truck roll. Utilities will see immediate improvement in the frequency of sustained outages on their system.

Another benefit of a lateral-reclosing strategy is it moves the reclosing closer to the problem, allowing only the faulted lateral to experience a blink. See Figure 3 on page 3.



The TripSaver II recloser's operating sequence

The TripSaver II Cutout-Mounted Recloser supports up to three reclosing operations (four tripping operations in total) before it drops open. Multiple varieties of time-current characteristic (TCC) curves are available. The duration of the open interval between tripping operations is user-configurable. It has a range from 0.5 seconds to 5 seconds.

An option with an extended open interval of up to 30 seconds is also available.

The vacuum interrupter resets 2 seconds after the TripSaver II recloser drops open. The operator can then manually close the TripSaver II recloser back in to the mounting after the repair has been made.

In instances when a transient fault clears before the TripSaver II recloser reaches the end of its operating sequence, the recloser will revert to its first TCC curve after its sequence reset timer expires. The sequence reset time is also user-configurable, and it has a range from 0.5 seconds to 1,000 seconds.

How the TripSaver II recloser works for a transient fault

Consider a transient fault downstream of the TripSaver II Cutout-Mounted Recloser. Using its fast TCC curve, the TripSaver II recloser opens, as shown in Figure 3. Only customers served from the lateral downstream of the TripSaver II recloser experience a momentary interruption.

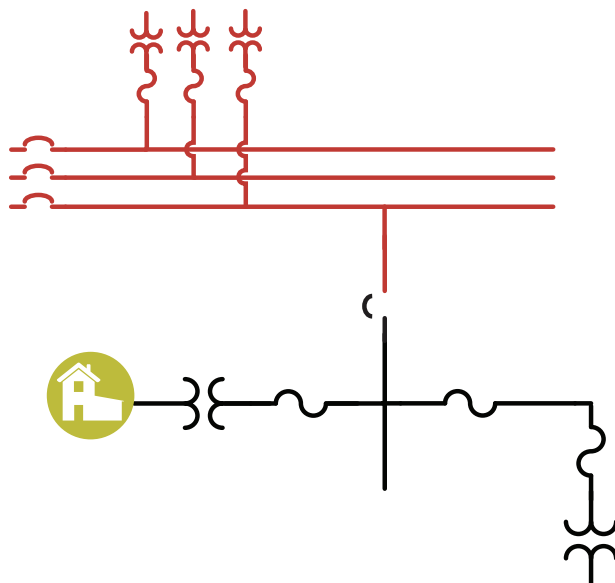

Figure 3. The TripSaver II recloser opens.

After the open interval, the TripSaver II recloser recloses, restoring power to customers served from the lateral downstream. Because the fault was transient and cleared, further tripping operations aren't needed. The TripSaver II recloser reverts to its first TCC curve after the sequence reset time.

How the TripSaver II recloser works for a persistent fault

Consider a persistent fault downstream of the TripSaver II recloser. Because the fault is persistent, the TripSaver II Cutout-Mounted Recloser performs further tripping operations per the specified TCC curves. For utilities using a "fuse-saving" philosophy, the TripSaver II recloser drops open at the end of its operating sequence in the same manner as a standard fuse cutout—providing visual indication the faulted lateral has been isolated, as shown in Figure 4. The vacuum interrupter resets 2 seconds after the TripSaver II recloser drops open. The recloser may then be manually closed back in to the mounting by the operator when the fault has been repaired.

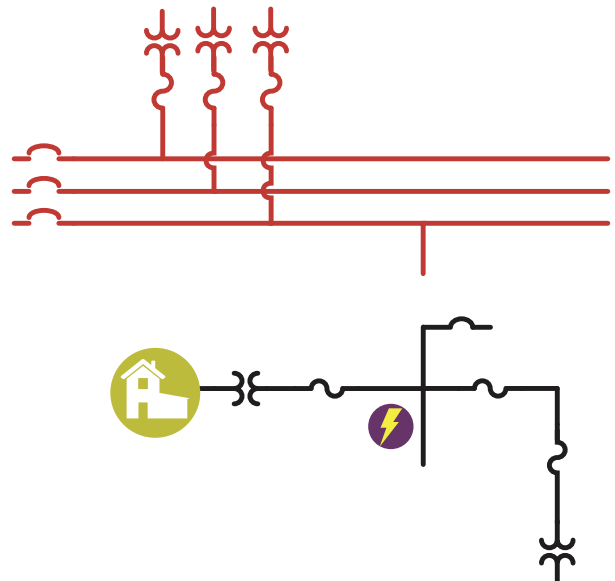
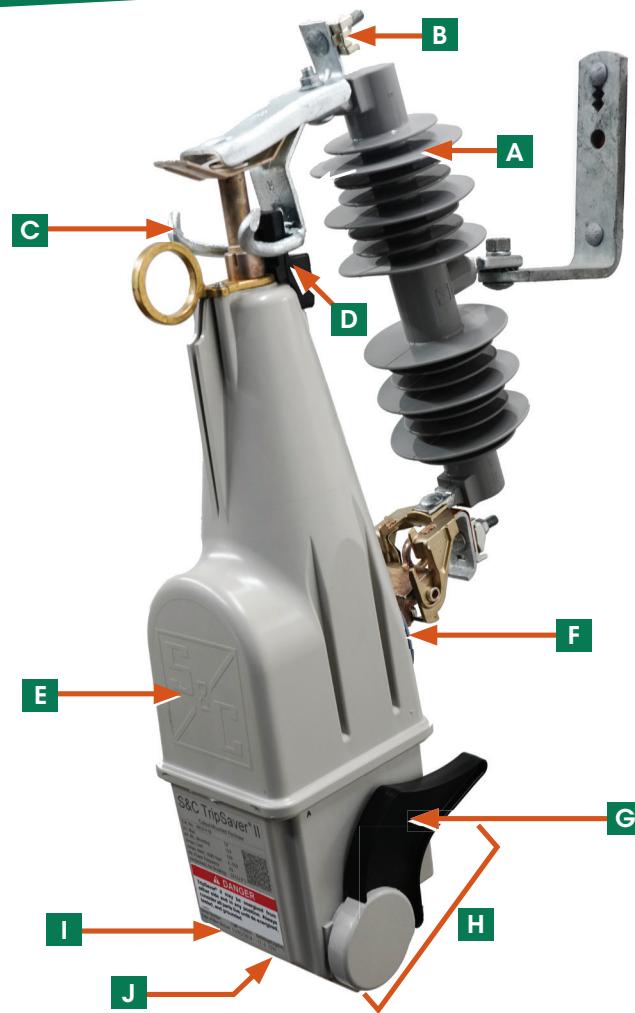

Figure 4. The TripSaver II recloser drops open.



- A Type XS Fuse Cutout Mounting**—With its birdproof design and composite polymer silicone or porcelain insulators, Type XS Fuse Cutout Mountings provide a higher level of characteristics than ANSI distribution cutout standards. TripSaver II reclosers can be installed in new or existing production (“-R10” or “-R11”) mountings.
- B Parallel-groove connector**—Fabricated of tin-plated cast red brass (For ease of connection, the recloser accommodates two conductors, even of unlike size.)
- C Attachment hooks**—These allow the TripSaver II recloser to be manually opened using Loadbuster®—The S&C Loadbreak Tool.
- D Bumper and retainer**—Unique to TripSaver II reclosers, this spring-loaded retainer and bumper dampen impact on closing, reducing the possibility of bounce-back.
- E Vacuum fault interrupter**—Located in the upper housing, it quietly contains and interrupts the fault without exhaust or sparking.
- F Trunnion**—High-strength cast bronze, silver-plated (Surfaces around the trunnion bear on broad hinge surfaces to keep the TripSaver II recloser in alignment during closing. Its special shape facilitates easy removal and reduces vibration.)
- G Tag-clip option**—This allows crews to tag the TripSaver II recloser in a highly visible location, required to communicate nonstandard conditions.
- H Mode-selector lever**—This allows crews working downstream of the TripSaver II recloser to select an automatic reclosing or nonreclosing operation.
- I LCD screen**—This displays user-configurable TripSaver II recloser status automatically, giving visibility for any crew member (no laptop needed).
- J Internal communications**—This allows the user to interact with the TripSaver II recloser wirelessly to handle programming and interrogation sessions without the need for a crew to be present.

Remote Drop Open

When configured with a TripSaver® II Communications Gateway, the new **Remote Drop Open** feature will allow a “drop open” SCADA command to be sent via DNP 3.0 through the communications gateway to the TripSaver II recloser.

Sequence Coordination

The **Sequence Coordination** feature maintains proper coordination between the TripSaver II Cutout-Mounted Recloser and downstream reclosers. If a fault is cleared by a downstream recloser, the TripSaver II recloser will shift to a user-configured (usually slower) time-current characteristic curve before fault testing. The TripSaver II recloser will maintain its sequence coordination setting until the **Coordination Reset** timer expires.

Sectionalizing Feature

The TripSaver II recloser features a **Sectionalizing** mode in both 4-kA- and 6.3-kA-rated models. When enabled, the recloser will operate as a sectionalizer over a user-specified range of fault currents when the source-side circuit breaker or recloser trips faster than the TripSaver II recloser does. It counts the number of operations of the source-side circuit breaker or recloser and drops open after a user-specified number of counts.

Inrush-Restraint Feature

The TripSaver II Cutout-Mounted Recloser has a novel **Magnetizing Inrush-Restraint** feature that is always on, measuring second-harmonic current to distinguish fault current from inrush current. If inrush current is detected, the TripSaver II recloser will not trip. The **Inrush-Restraint** feature facilitates lower minimum pickup currents down to 5 amperes.

Local Manual Open Feature

The **Local Manual Open** feature removes the requirement to use the S&C Loadbuster tool for loadbreaking by providing a manual operation sequence that commands the TripSaver II recloser to open the vacuum-interrupter contacts and drop open.

Non-Reclose TCC Curves

In earlier firmware versions, when the TripSaver II recloser NON-RECLOSE lever was in the **Down** (activated) position, the instantaneous TCC curve was automatically activated. The new **Non-Reclose** feature allows the user to configure three TCC curves from the library for use during **Non-Reclose** mode. These new TCC curves are named the Standard Non-Reclose TCC curve, the Post Fault Non-Reclose TCC curve, and the Cold Wake-up Non-Reclose TCC curve. The curve that will be active is dependent on the load or fault condition prior to **Non-Reclose** mode activation or when a dropout previously occurred. The TCC curve selection will occur automatically without requiring the operator to manually select the appropriate settings. **Non-Reclose** (NR) mode can also be set remotely (**Remote Non-Reclose** (R-NR) mode) by a DNP 3.0 command when the TripSaver II recloser is properly configured with the gateway and transceiver.

Gang Operation Feature

When multiple TripSaver II reclosers are properly configured together with the TripSaver II Communications Gateway, the **Gang Operation** feature allows any TripSaver II recloser that responds to a protection drop-open event or to a Local Manual Open drop-open event to signal the gateway to send **Drop-open** commands to the other configured TripSaver II reclosers. See Figure 5.

When a permanent fault occurs...

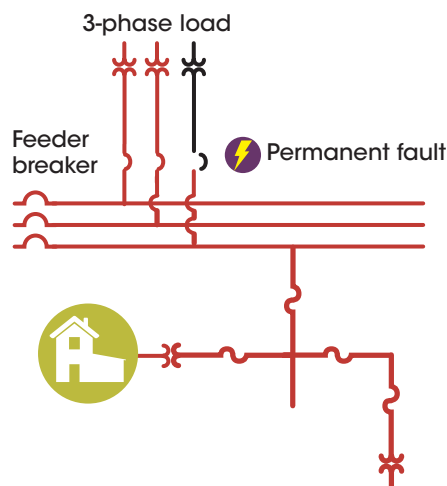

The TripSaver II recloser isolates the fault and sends a drop-open notification to the gateway.

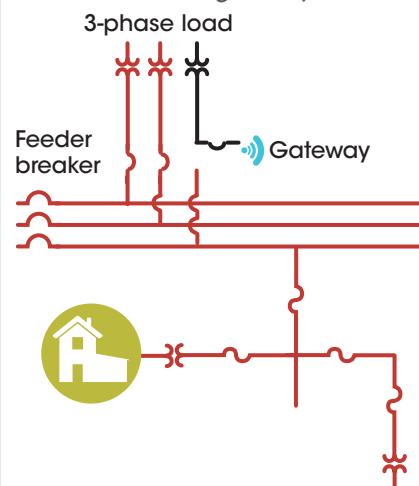

The gateway sends a Drop-open command to the remaining TripSaver II reclosers.

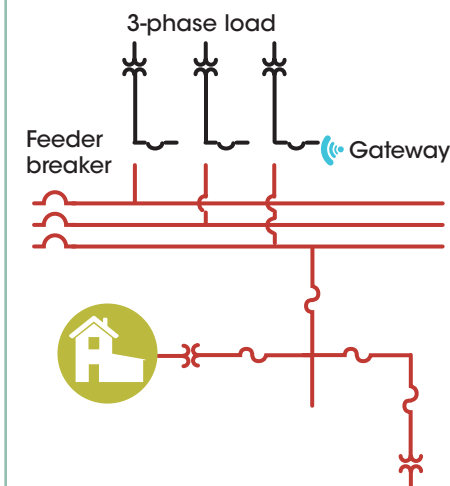

Figure 5. TripSaver II Communications Gateway Gang Operation feature.

TripSaver® II Communications via Gateway

The TripSaver II Cutout-Mounted Recloser offers a **Remote Communication** option using field-area networks already built for SCADA, advanced metering infrastructure, or distribution automation. See Figure 6. The remote communication provides the following data as DNP 3 functionality:

- Unsolicited alerts
- GPS time and coordinates
- Device heartbeat
- Remote mode-change capability

TripSaver II reclosers with the **Extended Open-Interval** feature and a communications gateway are required.

The communications gateway is a padlockable, weather-proof enclosure mounted directly on a utility pole. It includes a configurable gateway controller and provision for a radio of the customer's choice connected via an Ethernet or a serial port. The gateway uses control power from an overhead transformer and includes an optional backup battery for riding through a loss of control power to the communications gateway.

All gateway configurations include a door alarm system and an integrated multi-band antenna capable of supporting GPS, cellular radios, and 900-MHz ISM and 900-MHz MAS radios.



Figure 6. TripSaver II Communications Gateway.

TripSaver® II Service Center Configuration Software

The TripSaver II provides customers with flexibility to reconfigure their reclosers and read event logs using S&C TripSaver II Service Center Configuration Software. See Figure 7. The most-recent release includes TripSaver II Service Center Configuration Software version 1.8 and the USB transceiver version 1.6, which is required for use with the new configuration software. The combination of the new transceiver and software is fully backward-compatible with all previous versions of TripSaver II reclosers and snapshot files and should be used in place of any previous versions.

Service Center Configuration Kit

This portable configuration kit also includes a universal power supply for the TripSaver II recloser and a USB transceiver for a computer to communicate with the recloser.

The intuitive graphical user interface makes the configuration process quick and easy. The software also allows users to view status-related information, read event logs, and perform functional tests.

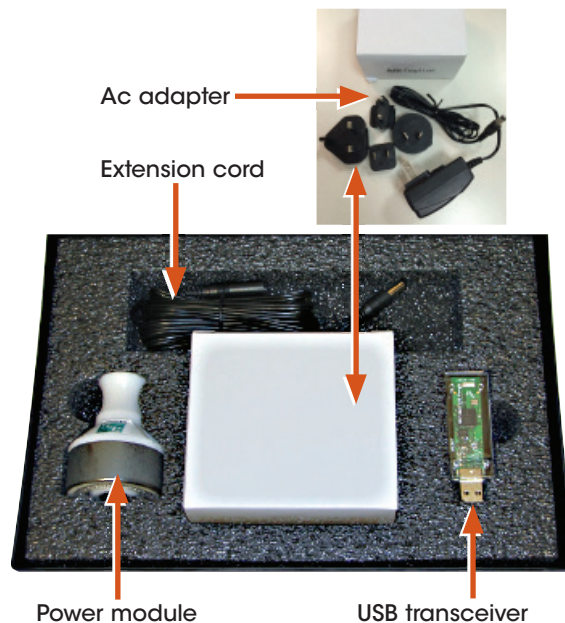

Figure 7. The service center configuration kit.

Table 1. Complete Overhead—Pole-Top Style TripSaver II Cutout-Mounted Recloser—

For a new installation. Includes TripSaver II recloser, cutout mounting (less mounting bracket), and connectors

50/60-Hz Ratings ^①					With Porcelain Insulator			With Polymer Insulator		
kV				Amperes, RMS ^②		Leakage Distance to Ground Minimum, Inches (mm)	Base Catalog Number	Leakage Distance to Ground Minimum, Inches (mm)	Base Catalog Number	
System Class	Nom.	Max	BIL	Cont.	Interr., Sym.					
15	15	15.5	110	40	4 000	8½ (216)	990511	14⅞ (378)	990511-P	
					6 300	8½ (216)	990611	14⅞ (378)	990611-P	
				100	4 000	8½ (216)	990111	14⅞ (378)	990111-P	
					6 300	8½ (216)	990211	14⅞ (378)	990211-P	
				200	4 000	8½ (216)	990311	14⅞ (378)	990311-P	
					6 300	8½ (216)	990411	14⅞ (378)	990411-P	
25	25	29	125	40	4 000	11 (279)	990522	-	-	
					6 300	11 (279)	990622	-	-	
			150	40	4 000	11 (279)	990532	19 (483)	990532-P	
					6 300	11 (279)	990632	19 (483)	990632-P	
			125	100	4 000	11 (279)	990122	—	—	
					6 300	11 (279)	990222	—	—	
			150	100	4 000	17 (432)	990132●	19 (483)	990132-P●	
					6 300	17 (432)	990232●	19 (483)	990232-P●	
			125	200	4 000	11 (279)	990322	—	—	
					6 300	11 (279)	990422	—	—	
			150	200	4 000	17 (432)	990332●	19 (483)	990332-P●	
					6 300	17 (432)	990432●	19 (483)	990432-P●	

① For 50-Hz applications, specify “microprocessor control” for application on 50-Hz systems, catalog number suffix “-F.”

② Minimum trip is 5 A for 40-A and 100-A TripSaver II reclosers; the minimum trip is 10 A for 200-A TripSaver II reclosers.

● Applicable for protection of single-phase-to-neutral circuits only in solidly grounded-neutral (multi-grounded-neutral) 34.5-kV systems where the leakage distance to ground meets user’s requirement. Uses 25-kV, 150-kV BIL, mounting.

Table 2. TripSaver II recloser only—For retrofitting in an existing present-production (“-R10” or “-R11”)

S&C-provided Type XS Fuse Cutout Mounting

Basic Catalog Number	50/60-Hz Ratings ^①						
	kV				Amperes, RMS ^②		
	System Class	Nom.	Max	BIL	Cont.	Interr., Sym.	Base Catalog Number
89811, 89021, 89031, 89071, 89221, 99021	15	15	15.5	110	40	4 000	997511
						6 300	997611
					100	4 000	997111
						6 300	997211
					200	4 000	997311
						6 300	997411
89812, 89022, 89032, 89072, 89802, 89042, 89052, 89092, 89222, 89223, 99022, 99042	25	25	29	125 or 150	40	4 000	997532
						6 300	997632
				125 or 150	100	4 000	997132
						6 300	997232
				125 or 150	200	4 000	997322
						6 300	997422

① For 50-Hz applications, specify the microprocessor control for application on 50-Hz systems, catalog number suffix “-F.”

② Minimum trip is 5 A for 40-A and 100 A TripSaver II reclosers. Minimum trip is 10 A for a 200-A TripSaver II reclosers.



S&C ELECTRIC COMPANY
Excellence Through Innovation

461-32

June 22, 2020

© S&C Electric Company 2012-2020, all rights reserved • sandc.com

