

## Specifications

### Conditions of Sale

**STANDARD:** The seller's standard conditions of sale set forth in Price Sheet 150 apply, except as modified under the "Warranty Qualifications" section on page 3.

### SPECIAL TO THIS PRODUCT:

**INCLUSIONS:** A TripSaver II Cutout-Mounted Recloser is ideally suited for protection of overhead laterals that experience frequent transient faults. This self-powered, microprocessor-controlled, single-phase vacuum interrupter is available for new installations or may be retrofitted in an existing present-production ("-R10" or "-R11") cutout mounting provided only by S&C.

The TripSaver II recloser eliminates the sustained interruption that results when a lateral fuse cutout operates in response to a transient fault. Utilities using a "fuse-blowing" philosophy will experience improved SAIFI without sacrificing MAIFI performance. The recloser also eliminates the momentary feeder interruption that results when the substation feeder circuit breaker or recloser is intentionally tripped, to prevent a lateral fuse cutout from operating in response to a transient fault. Utilities using a "fuse-saving" philosophy will experience improved MAIFI without sacrificing SAIFI performance.

The TripSaver II Cutout-Mounted Recloser can provide up to four trip operations. A wide variety of user-configurable time-current characteristic (TCC) curves is available. The duration of the open interval between trip operations and the reset time after the last reclose operation are user configurable. Sequence coordination with downstream reclosers is also supported. When this feature is enabled, if a fault is cleared by a downstream recloser, the TripSaver II recloser will shift to a user-configured (usually slower) TCC curve before fault testing. The TripSaver II recloser will maintain its sequence coordination setting until the sequence reset timer elapses.

The TripSaver II recloser drops open at the end of its operating sequence if the fault is persistent. The vacuum interrupter resets two seconds after the recloser drops open; the operator can then reclose the device into the mounting after the fault has been located and repairs have been made. The TripSaver II recloser is capable of dropping open under ¾-inch (19-mm) ice formation. The TripSaver II recloser can also break load current and drop open without the use of a loadbreaking tool.

The TripSaver II recloser has a novel **Inrush Restraint** feature that measures second-harmonic current to distinguish fault current from inrush current. If inrush current is detected, the TripSaver II recloser will not trip. The **Inrush Restraint** feature facilitates lower minimum pickup currents.

When downstream line work is to be performed, the recloser can be placed in the **Non-Reclose** mode by moving the mode-selector lever from the **Auto** (Up) position to the **NR** (Down) position. The TripSaver II recloser will open instantaneously in response to the NR TCC curve set. (It will not go through a reclosing sequence.) It also has new Cold Wakeup and Post-Fault Wakeup NR TCC curves that can be used when closing the TripSaver II recloser into its mounting with the MODE SELECTOR lever down. The MODE SELECTOR lever can be operated from the ground using a Talon™ Handling Tool or a distribution prong attached to an extendostick.

The TripSaver II recloser features a user-configurable **Sectionalizing** mode. When enabled, the recloser will operate as a sectionalizer over a user-specified range of fault currents when the source-side circuit breaker or recloser trips faster than the TripSaver II recloser. It counts the number of operations of the source-side circuit breaker or recloser and drops open after a user-specified number of counts. The counter resets if no sectionalizing event is registered during a user-specified period.



### Conditions of Sale—Continued

TripSaver II reclosers use a nonvolatile liquid-crystal display screen to show its operational information. The screen has two operating modes: **Normal**, which is the default mode, and the **Display** mode. The **Normal** mode shows the position of the vacuum interrupter contacts (**Open** or **Closed**), and the position of the mode-selector lever (**Auto** or **NR**). A user-selectable *Secondary Normal* screen shows the position of the vacuum interrupter contacts, the number of vacuum interrupter **Open** operations, and remaining contact wear in the form of a bar graph. The **Display** mode provides additional functional information and is activated by cycling the MODE SELECTOR lever. The TripSaver II recloser will scroll through the user-configurable items and the specified number of times before the display returns to the *Normal* screen.

When the vacuum interrupter reaches 10% of its remaining contact wear, a circular indicator will appear on the primary *Normal* screen. When the vacuum interrupter is no longer capable of interrupting a fault, the TripSaver II recloser will drop open and will not reset, locking the vacuum interrupter in the **Open** position and the operating mechanism in the **Dropped-Open** position. The recloser must be returned to S&C for service. An X-shaped indicator will appear on the primary *Normal* screen if the TripSaver II recloser has dropped open because of an overload. The nonvolatile screen maintains a TripSaver II *Normal* screen status if control power is lost.

Complete TripSaver II recloser models for a new installation include two parallel-groove connectors accommodating No. 6 solid (13.3 mm<sup>2</sup>) through No. 2 stranded (44.4 mm<sup>2</sup>) copper or aluminum in one groove, and No. 2 solid (33.6 mm<sup>2</sup>) through 250 kc mil (168 mm<sup>2</sup>) stranded copper or aluminum or 4/0 ACSR (161 mm<sup>2</sup>) in the other groove.

The TripSaver II recloser has been tested to, and is in compliance with, IEEE Standards C37.60-2012 and C37.41-2008 and IEC Standard 62271-111. The TripSaver II recloser is manufactured in accordance with a quality system certified to ISO 9001:2000.

### Service Center Configuration Kit

A configuration kit is required to configure the operating parameters of the TripSaver II recloser in the user's service center or other suitable indoor location. The configuration software additionally permits the user to check the basic status of the recloser, view historical data, and perform functional tests. The configuration kit includes a power supply, a USB transceiver for the user's computer, an instruction sheet, white adhesive labels for recording user-configured parameters, and a storage case. The configuration kit is compatible with all TripSaver II recloser models. The configuration software version 2.1, which is compatible with all TripSaver II firmware versions, can be downloaded from the S&C Automation Customer Support Portal. The USB Transceiver version 1.6 or 2.0 is required for use with the software version 2.1.

## Conditions of Sale—Continued

### **TripSaver® II Communications via Gateway**

This remote-communication option uses legacy field-area networks already built for long-range SCADA, advanced metering infrastructure, or distribution automation. The remote communication provides unsolicited alerts, GPS time and coordinates, device heartbeat, and remote mode-change capability via the DNP3 protocol. The communication gateway supports a **Gang-Operation** feature which allows the gateway to send local short-range drop-open signals to up to three gateway-configured TripSaver II reclosers. Optionally, the TripSaver II recloser supports a **Remote Drop Open** function that can be factory enabled prior to shipment. This feature allows the user to configure the TripSaver II recloser with a communications gateway, to receive and perform **Remote Drop Open** commands via DNP3. The communication gateway is housed in a padlockable weatherproof enclosure. An optional back-up battery is available for operating through a loss of control power to the communication gateway. TripSaver II reclosers with the extended open-interval capability (“-O” option suffix) are required to communicate with the gateway. An option to use the IEC 60870-5-104 protocol instead of DNP3 is also available.

#### **Notes:**

- All communication gateways include a door alarm system and an integrated S&C antenna that supports the following:
  - GPS
  - 890- to 960-MHz /1700- to 2700-MHz bands
- This default integrated S&C antenna will be used for cellular radios, 900-MHz ISM, and 900-MHz MAS radios. No separate antenna is required.
- For 403- to 470-MHz band radios, a separate antenna is required. Refer to Tables 9 and 11 on pages 15 and 16.
- More radios will be added to the list in the future. For other radios not yet in the table, contact S&C.

**EXCLUSIONS:** S&C may be able to furnish and install in the TripSaver II Communication Gateway, or make provision for, a customer-specified communication device not listed in Table 8 on pages 13 and 14. S&C will need to evaluate the physical and electrical requirements of the communication device and its performance characteristics and conduct qualification testing to verify its suitability for the desired application. S&C cannot furnish or install any communication device for which the supplier requires S&C to offer Tier I (i.e., “help desk”) support.

**APPLICATION NOTE:** The TripSaver II recloser selected for a specific application should have a maximum voltage rating equal to or greater than system line-to-line voltage when used in phase-to-phase applications. TripSaver II recloser models rated 25 kV, 150 kV BIL can be applied to protect single-phase-to-neutral circuits only in solidly grounded-neutral (multi-grounded-neutral) 34.5-kV systems where leakage distance to ground meets the user’s requirement. These models use a 25-kV, 150-kV BIL mounting.

**WARRANTY QUALIFICATIONS:** The standard warranty contained in the seller’s standard conditions of sale (as set forth in Price Sheet 150) does not apply to TripSaver II Cutout-Mounted Reclosers installed in other than a present-production (“-R10” or “-R11”) S&C-only cutout mounting.

Warranty of the TripSaver® II Communications Gateway is contingent on the installation, configuration, and use of the software in accordance with S&C’s applicable instruction sheets. This warranty does not apply to major components not of S&C manufacture, such as communication devices and antennas. However, S&C will assign to the immediate purchaser or end user all manufacturers’ warranties that apply to such major components.

**END USER LICENSE AGREEMENT:** End user is granted a nontransferable, non-sublicensable, non-exclusive license to use TripSaver® II Service Center Configuration Software and/or other software furnished with TripSaver II Cutout-Mounted Reclosers only on acceptance of all the terms and conditions of the seller’s end user license agreement set forth in Price Sheet 155.

## Anatomy of a TripSaver II Recloser Catalog Number

**Example Base Catalog Number:** 990511-P is a 15-kV, 110-BIL, 40-A continuous 4-kA interrupting TripSaver II recloser complete with a polymer cutout mounting

### Optional Features

**Example:** If a NEMA Type B mounting bracket and harsh-environment design are to be added to the polymer cutout mounting, and an extended open interval is required to be added to the TripSaver II recloser, the full catalog number with options would be:

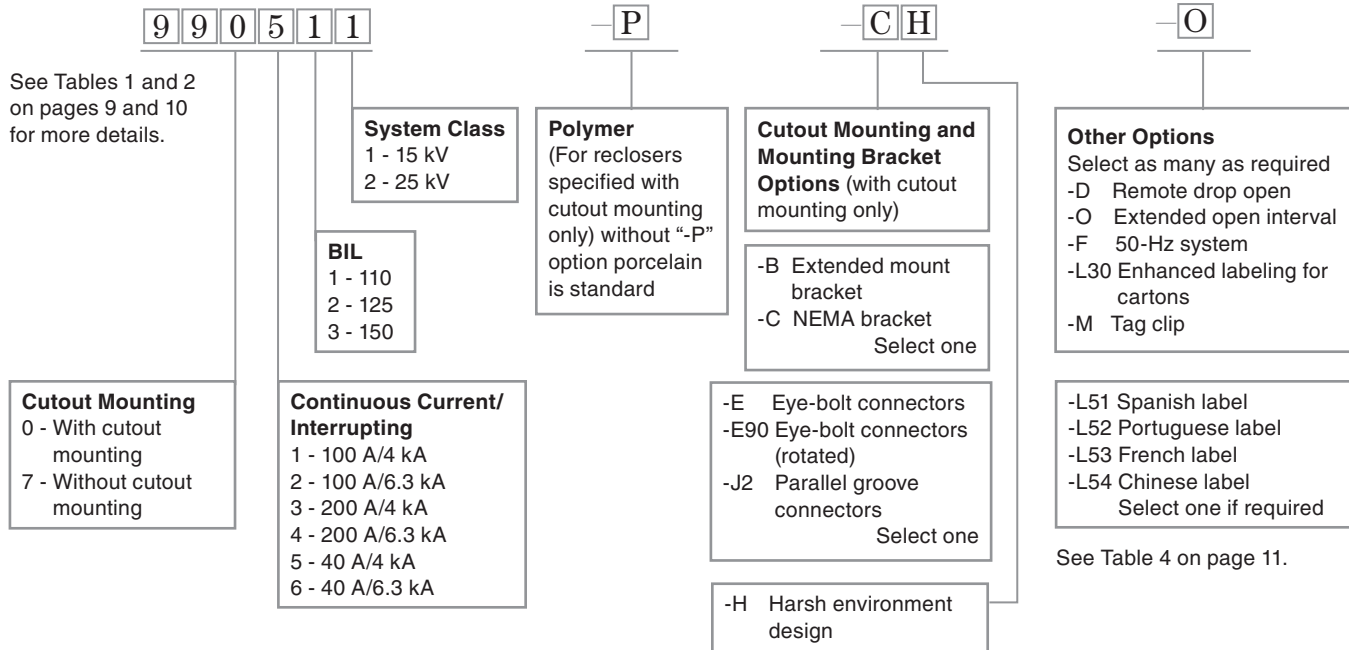

### Anatomy of a Communications Gateway Catalog Number

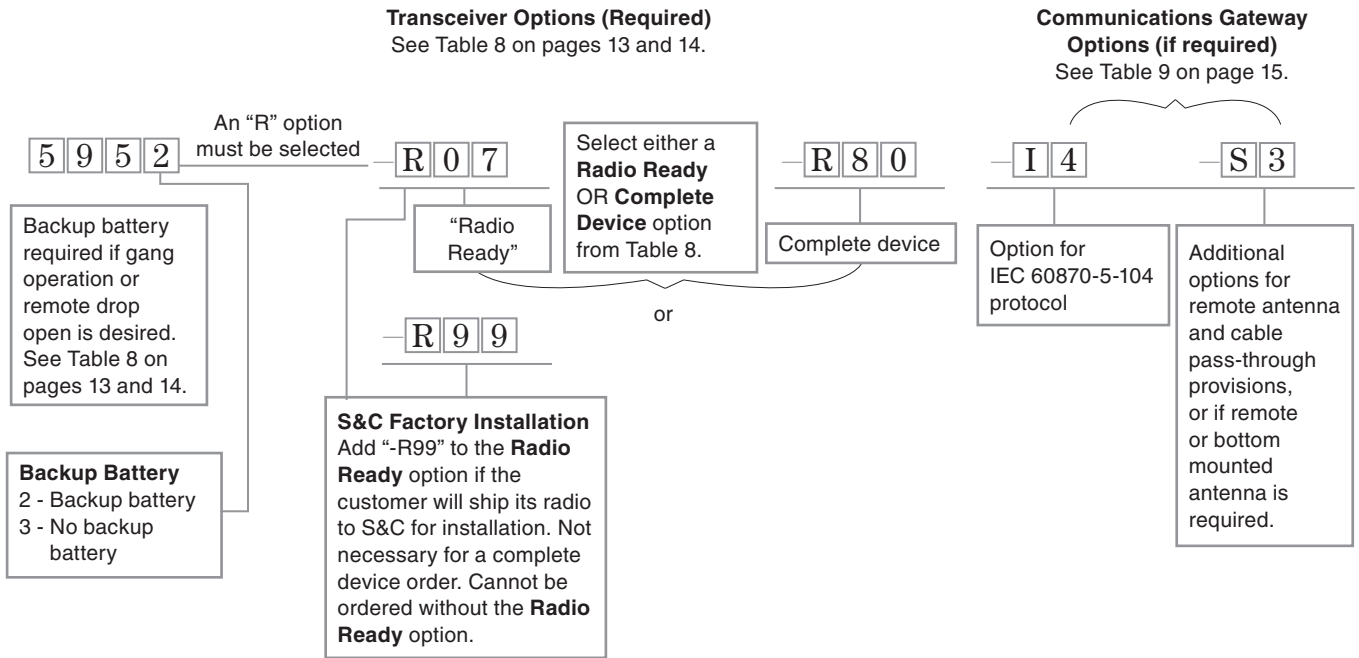

**Example 1:** If the customer will supply and install the transceiver, select an option from the "Radio-ready" section of Table 8. To specify provisions for a MDS TransNET 900 Transceiver:  
**5 9 5 2 -R 0 7**

**Example 2:** If a customer-supplied transceiver will be shipped to S&C for installation, specify both a **Radio Ready** option and the **Factory Installation** option "-R99". To specify a MDS TransNET 900 Transceiver installed by S&C:  
**5 9 5 2 -R 0 7 -R 9 9**

**Example 3:** To specify a "cellular-ready" gateway with two surge arresters for the main and diversity antennas:  
**5 9 5 2 -R 2 6 3 -S 1 8**

**Example 4:** To specify a "fiber-optic modem-ready" gateway with a hole for pass through fiber-optic cable:  
**5 9 5 2 -R 3 4 1 -S 1 9**

## How to Order a TripSaver II Recloser for a New Installation

**STEP 1.** Obtain the base catalog number of the desired TripSaver II recloser from Table 1 on page 9, taking care to match the system voltage class rating to the voltage of the system.

*Catalog Number:* 9 9 0 5 1 1 - P

**STEP 2.** If desired, select the cutout and mounting bracket options from Table 3 on page 10, and add the indicated catalog number suffix(es) to the catalog number selected in Step 1.

*Suffix(es):* - B, - H, - E 9 0

**STEP 3.** Select any additional desired options from Table 4 on page 11, and add the indicated catalog number suffix(es) to the catalog number selected in Step 1.

*Suffix(es):* - D, - F, - L 3 0, - M, - O

## How to Order a TripSaver II Recloser for Retrofitting in Existing S&C-Only Cutout Mountings

**Note:** TripSaver II reclosers may be retrofitted only in an existing present-production (“-R10” or “-R11”) S&C-only cutout mounting.

Follow these steps to order a TripSaver II recloser for retrofitting in existing S&C-only cutout mountings:

**STEP 1.** Obtain the base catalog number of the desired TripSaver II recloser from Table 2 on page 10, taking care to match the system voltage class rating to the voltage of the system.

*Catalog Number:* 9 9 7 5 1 1

**STEP 2.** Select any additional desired options from Table 4 on page 11, and add the indicated catalog number suffix(es) to the catalog number selected in Step 1.

*Suffix(es):* - D, - F, - L 3 0, - M, - O

## How to Order Configuration Kit and/or Replacement Parts

**STEP 1.** Obtain the catalog number of the TripSaver II configuration kit and any optional replacement parts from Table 5 on page 11.

*Catalog Number:* 5 9 5 0 R 2  
F D A - 1 8 6 8 R 2  
5 9 5 1  
5 9 5 4

## How to Order Handling Tools

**STEP 1.** Obtain the catalog number of the recommended handling tool(s) from Table 6 on page 12.

*Catalog Number:* 4 4 1 6  
4 4 4 0

### How to Order a Communication Gateway and/or Accessory

**STEP 1.** Obtain the catalog number of the desired communication gateway from the “Communication Gateway” section of Table 8 on page 13.

*Catalog Number:* 5952

**STEP 2.** Select the desired transceiver and provision type (radio ready or complete device) from the “Mandatory Suffix for Transceiver” section of Table 8 on pages 13 and 14, and add the suffix to the catalog number selected in Step 1. For radio ready, add “-R99” option suffix for a S&C factory-installation of a transceiver furnished by the customer (customer ships the transceiver to S&C).

*Mandatory Suffix:* 5952-R07

**Example:** To order a TripSaver II Communication Gateway with a backup battery and to have S&C install a customer-supplied MDS SD9 Remote Radio before shipping the completed communication gateway, specify:

*Suffix:* 5952-R188-R99

**Note:** All gateway provisions include a door alarm system and an integrated S&C antenna that supports the following:

- GPS
- 890- to 960-MHz/1700- to 2700-MHz bands

This default integrated S&C antenna will be used for cellular radios and 900-MHz ISM and 900-MHz MAS radios. No separate antenna is required. For 403- to 470-MHz band radios, an antenna is required.

**STEP 3.** Add a desired antenna connector suffix from Table 9 on page 15 to the communication gateway catalog number. This must be specified at time of order.

*Suffix:* S18

**STEP 4.** If IEC 60870-5-104 Protocol capability is required, add the “-I4” suffix from Table 9 on page 15.

*Suffix:* I4

**STEP 5.** Select the desired power cable from Table 10 on page 15. The power cable previously acquired for a SpeedNet repeater can be used with the communication gateway for TripSaver II reclosers.

**Example:** To order a 20-foot (610-cm) ac power cable, specify:

*Catalog Number:* 007-002100-02

**STEP 6.** Select a desired three-prong ac power cable for gateway indoor programming use from the Table 12 on page 16. This cable can be shared with other gateways, and S&C recommends keeping a minimum of one cable for each service center.

**Example:** To order a 6-foot (183-cm) ac power cable for gateway indoor programming use, specify catalog number:

*Catalog Number:* 007-002101-01

Proceed to Step 7 if using a 403- to 470-MHz band radio with a local or remote antenna, or if using a 902- to 928-MHz band radio with remote antenna.



**STEP 7.** If desired, obtain the catalog number of an S&C-provided antenna from Table 11 on page 16.

*Catalog Number:*

9	0	3	-	0	0	2	7	0	2	-	0	2
---	---	---	---	---	---	---	---	---	---	---	---	---

The optional backup battery is used for operating during a loss of control power to the communication gateway. If desired, a backup battery can be ordered and added to a batteryless communication gateway later by obtaining the catalog number of the backup battery system kit in Table 12 on page 16.

**Note:** A TripSaver II recloser with the **Extended Open-Interval** option (“-O” option suffix) is required for working with the communication gateway. A firmware update may be required. A TripSaver II recloser with the **Extended Open-Interval** option **MUST** be user-configured to the **Gateway Mode** setting using the TripSaver II Service Center Configuration Software version 1.6 or later before it can communicate with the communication gateway. All TripSaver II reclosers with the **Extended Open-Interval** option will be set to the **Non-Gateway Mode** setting before they leave S&C’s factory **UNLESS** a factory configuration is requested.



**Table 1. Complete Overhead—Pole-Top Style TripSaver II Cutout-Mounted Recloser—For a new installation; Includes TripSaver II recloser mounting (less mounting bracket) and connectors**

50/60-Hz Ratings <sup>①</sup>						With Porcelain Insulator		With Polymer Insulator	
kV				Amperes, RMS <sup>②</sup>		Leakage Distance to Ground Minimum, Inches (mm)	Base Catalog Number	Leakage Distance to Ground Minimum, Inches (mm)	Base Catalog Number
System Class	Nom.	Max	BIL	Cont.	Interr., Sym.				
15	15	15.5	110	40	4 000	8½ (216)	990511	14¾ (375)	990511-P
					6 300	8½ (216)	990611	14¾ (375)	990611-P
				100	4 000	8½ (216)	990111	14¾ (375)	990111-P
					6 300	8½ (216)	990211	14¾ (375)	990211-P
				200	4 000	8½ (216)	990311	14¾ (375)	990311-P
					6 300	8½ (216)	990411	14¾ (375)	990411-P
25	25	29	125	40	4 000	11 (279)	990522	—	—
					6 300	11 (279)	990622	—	—
			150	40	4 000	17 (432)	990532●	26½ (673)	990532-P●
					6 300	17 (432)	990632●	26½ (673)	990632-P●
			125	100	4 000	11 (279)	990122	—	—
					6 300	11 (279)	990222	—	—
			150	100	4 000	17 (432)	990132●	26½ (673)	990132-P●
					6 300	17 (432)	990232●	26½ (673)	990232-P●
			125	200	4 000	11 (279)	990322	—	—
					6 300	11 (279)	990422	—	—
			150	200	4 000	17 (432)	990332●	26½ (673)	990332-P●
					6 300	17 (432)	990432●	26½ (673)	990432-P●

① For 50-Hz applications, specify Microprocessor Control for Application on 50-Hz Systems, catalog number suffix “-F.” See Table 4 on page 11.

② Minimum trip current is 5 amperes for 40 A continuous, 5 amperes for 100 A continuous and 10 amperes for 200 A continuous TripSaver II reclosers.

● Applicable for protection of single-phase-to-neutral circuits only in solidly-grounded-neutral (multi-grounded-neutral) 34.5-kV systems where leakage distance to ground meets user’s requirement. Uses 25-kV, 150-kV BIL mounting.

# TripSaver® II Cutout-Mounted Recloser

**Table 2. TripSaver II Cutout-Mounted Recloser Only—For retrofitting in an existing present-production (“-R10” or “-R11”) S&C-only cutout mounting**

For Use with S&C-Only Cutout Mounting Basic Catalog Number	50/60-Hz Ratings <sup>①</sup>						Base Catalog Number
	kV				Amperes, RMS <sup>②</sup>		
	System Class	Nom.	Max	BIL	Cont.	Interr., Sym.	
89811, 89021, 89031, 89071, 89221, 99021	15	15	15.5	110	40	4 000	997511
						6 300	997611
					100	4 000	997111
						6 300	997211
					200	4 000	997311
						6 300	997411
89812, 89022, 89032, 89072, 89802, 89042, 89052, 89092, 89222, 99022, 99042	25	25	29	125 or 150	40	4 000	997532
						6 300	997632
				125 or 150	100	4 000	997132
						6 300	997232
				125 or 150	200	4 000	997322
						6 300	997422

① For 50-Hz applications, specify “Microprocessor Control for Application on 50-Hz Systems,” catalog number suffix “-F.” See Table 4 on page 11.

② Minimum trip current is 5 amperes for 40 A continuous, 5 amperes for 100 A continuous and 10 amperes for 200 A continuous TripSaver II reclosers.

**Table 3. Cutout Mounting and Mounting Bracket Options—For Overhead Pole-Top Style TripSaver II Recloser Models**

Item				Add Catalog Number Suffix
S&C extended mounting bracket, for crossarm, pole, or wall mounting				-B
NEMA Type B mounting bracket, for crossarm mounting				-C
Harsh environment design. All galvanized steel components and hardware replaced with stainless steel to provide enhanced corrosion resistance in coastal or high contamination environments				-H
Item	Accommodating Conductors		Position	Add Catalog Number Suffix
	Quantity	Size and Material		
Eye-bolt connectors <sup>①</sup>	One	No. 8 solid (8.4 mm <sup>2</sup> ) through 250 kc mil (168 mm <sup>2</sup> ) stranded copper or aluminum, or 4/0 ASCR (161 mm <sup>2</sup> )	Standard orientation	-E
			Lower connector rotated 90°	-E90
Parallel-groove connectors	Two	No. 6 solid (1.33 mm <sup>2</sup> ) through No. 2 stranded (44.4 mm <sup>2</sup> ) copper or aluminum in on groove; No. 2 solid (33.6 mm <sup>2</sup> ) through 250 kc mil (168 mm <sup>2</sup> ) stranded copper or aluminum or 4/0 ASCR (161 mm <sup>2</sup> ) in the other groove (two-piece design)	Standard orientation	-J2

① The same as the “-M” and “-M90” options for fuse cutouts described in Specification Bulletin 351-31.

**Table 4. Other Options**

Item		Add Catalog Number Suffix
Remote drop open. This feature allows the TripSaver II recloser, when paired with a communications gateway, to drop open when the communications gateway is signaled via DNP3 <sup>①</sup>		-D
Microprocessor control for application on 50-Hz systems		-F
Enhanced labeling for shipping cartons <sup>②</sup>		-L30
Danger label in other languages	Spanish	-L51
	Portuguese	-L52
	French	-L53
	Chinese	-L54
Tag clip—Allows tag to be affixed to MODE-SELECTOR lever (does not lock out device)		-M
Extended open interval		-O

<sup>①</sup> Extended open interval option “-O” required.

<sup>②</sup> When the TripSaver II Cutout-Mounted Recloser is ordered complete with a cutout mounting, the cutout mounting is shipped in a separate carton from the recloser. This option adds “Carton 1 of 2” and “Carton 2 of 2” identifier labels to the outside of the cutout mounting and TripSaver II recloser cartons. Not available for catalog numbers 997111, 997211, 997132, 997232, 997322, and 997422.

**Table 5. Configuration Kit and Replacement Parts—For All TripSaver II Recloser Models**

Item	Catalog Number	
TripSaver II recloser configuration kit, less power supply ac adapter. Includes: <ul style="list-style-type: none"> <li>• Power supply, less ac adapter</li> <li>• USB transceiver with enhanced antenna for user's computer</li> <li>• 20 adhesive labels on which configuration parameters can be written (The labels attach to the left side of the lower TripSaver II recloser housing.)</li> <li>• Quick Start Guide</li> <li>• Storage case</li> </ul>	5949R2	
TripSaver II recloser configuration kit. Includes: <ul style="list-style-type: none"> <li>• Power supply</li> <li>• USB transceiver with enhanced antenna for user's computer</li> <li>• 20 adhesive labels on which configuration parameters can be written (The labels attach to the left side of the lower TripSaver II recloser housing.)</li> <li>• Quick Start Guide</li> <li>• Storage case</li> </ul>	5950R2	
Replacement power supply	TA-3280	
Replacement USB transceiver with external antenna	FDA-1868R2	
Twenty adhesive labels for user-configured parameters	FDA-1867	
Magnet tool	5951	
Cordless power module	with lithium battery	5954
	without lithium battery	5955

# TripSaver® II Cutout-Mounted Recloser

---

**Table 6. Recommended Handling Tools—For All TripSaver II Recloser Models**

Item	Catalog Number
Station prong	4402R2
Distribution prong	4416
Talon™ Handling Tool	4440
Universal pole	●

● Select to match height of installation. Refer to Specification Bulletin 851-31.

**Table 7. Services—For All TripSaver II Recloser Models**

Item
Inspection and maintenance service. Includes inspection, cleaning, functional testing, and replacement of the vacuum interrupter. Does not include repairs and/or replacement of additional parts required caused by mishandling or other causes.
To ensure proper order processing, refer to the nearest S&C Sales Office to obtain a special serially numbered label to place on the shipping box in which the TripSaver II recloser is returned. The TripSaver II recloser should be carefully packed, with a packing slip enclosed showing purchase-order or requisition number covering the inspection and maintenance service. The TripSaver II recloser should be shipped, transportation charges prepaid, to S&C Electric Company. For product returns, contact the local S&C Sales Office for proper return material authorization documentation.

**Table 8. Communications Gateway and Transceiver①**

Communications Gateway		Catalog Number	
Communications gateway	With backup battery included	5952	
	Without backup battery	5953	
Mandatory Suffix for Transceiver			
Gateway Configuration Type	Transceiver Description	Transceiver Type	Add Mandatory Catalog Number Suffix to Gateway Catalog Number
Radio-ready ("provisions-only;" transceiver installed later by customer)	MDS TransNET 900 Transceiver	Radio	-R07
	FreeWave FGR-115RC	Radio	-R30
	Internal MDS iNET 900 Dual Gateway: Ethernet and serial remote	Radio	-R34
	Landis+Gyr Series 4 IWR	Radio	-R66
	SpeedNet™ Radio	Radio	-R88
	FreeWave FGR2-PE-U/ FGR2-PE / HT-PE	Radio	-R179
	MDS SD9 Remote Radio	Radio	-R188
	SpeedNet™ ME Mesh End-Point Radio	Radio	-R241
	GE MDS SD4 MDCEsnnsnn licensed managed radio, ES C Band 450-512 MHz, with two serial ports + one Ethernet port	Radio	-R260
	Tantalus TUNet® DA-1710 Bridge Radio	Radio	-R273
	GE MDS™ MCR High Port Density Radio, licensed 896-960 MHz, 1X TNC connector	Radio	-R307
	Silver Spring Networks Bridge 4.0 Radio (catalog number 205-000043)	Radio	-R326
	Harris SG5300-800, 1X, TNC antenna connector	Radio	-R339
	Phoenix Contact RAD-ISM-900-EN-BD, 900-MHz ISM Band	Radio	-R346
	MDS SD2 remote radio	Radio	-R357
	FreeWave ZumLink Z9-PE2	Radio	-R360
	XetaWave-unlicensed Xeta9-EIOL	Radio	-R365
	Wisebox M4F Cellular Modem Radio	Radio	-R370
	GE MDS Orbit ECR Radio, Unlicensed 902-928 MHz with 1X TNC antenna connector	Radio	-R382
	GE MDS Orbit MCR Radio, Licensed 406.1-470 MHz with 1X TNC antenna	Radio	-R387
	Sierra Wireless GX450 Cellular Radio (model number 1102326)	Cellular	-R263
	Sensus RTMII Cellular Radio	Cellular	-R301
	DiGi Transport® WR31 Radio (model number WR31-L52A-DE1-TB)	Cellular	-R308
	Sierra Wireless RV50 radio	Cellular	-R316
	Sixnet SN-6801-GE Cellular Radio	Cellular	-R325
	GE MDS Orbit ECR Wireless Router with a single WAN radio	Cellular	-R328
	Cisco IR807 router	Cellular	-R330
	GE MDS Orbit MCR, High Port Density, 4G LTE cellular with 2X SMA antenna connectors	Cellular	-R332
	4RF Aprisa SR+, 2X TNC antenna connection	Cellular	-R338
	Cisco 809 Router, 2X TNC antenna connection	Cellular	-R340
Cradlepoint COR IBR900 radio	Cellular	-R355	
Vanguard VG5530-LVZ-F VZAT, (with 2 SMA antenna connectors)	Cellular	-R358	
SpeedNet™ Cell Edge Gateway 4G LTE cellular modem with removable SIM for USA and Canada	Cellular	-R369	
Moxa EDS-4008-2GT-2GS-LV Ethernet switch with SFP fiber-optic port	Ethernet switch	-R397	

TABLE CONTINUED ►

FOOTNOTES AND NOTES ON PAGES 14 AND 15 ►

**Table 8. Communication Gateway and Transceiver<sup>①</sup>—Continued**

Mandatory Suffix for Transceiver			
Gateway Configuration Type	Transceiver Description	Transceiver Type	Add Mandatory Catalog Number Suffix to Gateway Catalog Number
Radio-ready ("provisions-only;" transceiver installed later by customer)	RLH Industries ETH-52G-1 SFP switch with SFP fiber-optic port	Ethernet switch	-R398
	Landis+Gyr Series 5 network-integrated WanGate radio (IWR)	Radio	-R399
	Antaira LNX-0501G-SFP-T unmanaged Ethernet switch with SFP ports	Ethernet switch	-R400
	Antaira LMX-0702G-SFP-T-V2 managed fiber-optic Ethernet switch with SFP ports	Ethernet switch	-R404
	ARG600A1260NA cellular, single SIM variant wireless gateway	Cellular	-R384
	Nokia SAR-7705-HMC (Private LTE, 3.6 GHz), requires 2X antenna connections	Cellular	-R378
	Peplink Pepwave Max BR1 Mini Core Radio	Cellular	-R395
	RuggedCom RP100 PoE Injector and RUM 99-55-0023-001 Ethernet surge arrester (to support external WiN5218-5 High Gain Outdoor Subscriber unit.) <sup>②</sup>	PoE Ethernet	-R351
	TropOS 6420 external Ethernet device	Ethernet	-R323
	GarrettCom Magnum CSG14UP Universal Premium	Fiber-optic	-R341
	Nokia 7368 ISAM ONT G-241G-A, SC/APC connector for single mode fiber (with mux and demux functions to the PON)	Fiber-optic	-R371
DZS SNID-GPON-2424A1, SC/APC connector for fiber-optic cable	Fiber-optic	-R391	
Complete device (factory installation of transceiver furnished by S&C)	MDS TransNET 900 Transceiver with diagnostics	Radio	-R19
	FreeWave FGR2-PE-U radio	Radio	-R185
	CALAMP Viper SC+, IP router	Radio	-R194
	GE MDS SD4 MDCEsnnsnn licensed managed radio, ES C band, 450-512 MHz, with two serial ports + one Ethernet port	Radio	-R259
	SpeedNet™ Cell Edge Gateway 4G LTE cellular modem with removable SIM for USA and Canada	Cellular	-R352
	Vanguard VG5530-LVZ-F VZAT, (with 2 SMA antenna connectors)	Cellular	-R359
	Moxa EDS-4008-2GT-2GS-LV fiber-optic Ethernet switch with SFP ports	Ethernet switch	-R405
S&C factory installation of customer supplied transceiver	S&C factory installation of radio furnished by the customer (customer ships the radio to S&C) <sup>③</sup>	—	-R99

① Three types of transceiver options are in Table 8:

Option Type	Description
Radio Ready, Ready For, or Provisions Only	S&C makes the gateway modifications to connect the transceiver, but the transceiver is customer supplied and installed
S&C supplied and installed	S&C supplies the transceiver and installs it prior to shipment
-R99	Customer supplies an approved transceiver (listed in Table 8) to S&C, and S&C installs it prior to shipment

② Specify communications gateway catalog number option "-S19" at time of order along with the appropriate cable pass-through diameter. See Table 9 on page 15.

③ The **Radio Ready** option must be ordered with factory installation (-R99).

**Table 9. Communications Gateway Options**

Item	Description	Add Catalog Number Suffix
IEC 60870-5-104 protocol	Gateway configured for IEC 60870-5-104 (IEC 104) protocol and supplied with IEC 104 instruction sheets	-I4
Antenna connector and cable pass-through options <sup>①</sup>	N-type female connector, bottom-mounted, for local antenna	-S2
	PolyPhaser surge suppressor (125 MHz to 2.3 GHz) N-type connector, bottom-mounted, for remote antenna	-S3
	1.47-inch (37-mm) hole for customer 0.59- to 0.99-inch (15- to 25-mm)-diameter cable	-S15
	Ready for permanent-mount antenna, Double D hole only with cover	-S16
	Two (2), N-type female connectors, bottom-mounted, for local antenna	-S17
	Two (2), PolyPhaser surge suppressor (125 MHz to 2.3 GHz) N-type connectors, bottom-mounted, for remote antenna	-S18
	Pass-through hole for cable. Diameter, between .0625 (1.6 mm) and 2 inches (51 mm), to be determined by customer <sup>②</sup>	-S19

<sup>①</sup> Order the antenna-connector option if using either:

- A 403- to 470-MHz band radio with local or remote antenna
- A 902- to 928-MHz band radio with remote antenna

This must be specified at time of order.

<sup>②</sup> Specify cable diameter at time of order. Contact the local S&C Sales Office for details.

**Table 10. Ac Power Cables**

Ac Power Cable	Catalog Number
10-foot (304.8-cm) unterminated wire	007-002100-01
15-foot (457.2-cm) unterminated wire	007-002100-06
20-foot (609.6-cm) unterminated wire	007-002100-02
25-foot (762.0-cm) unterminated wire	007-002100-03
30-foot (914.4-cm) unterminated wire	007-002100-04
55-foot (1676.4-cm) unterminated wire	007-002100-05



**Table 11. Communication Gateway—Other S&C-Provided Antennas**

S&C-Provided Antennas			Catalog Number
Remote antenna kit	902- to 928-MHz 3-dBi antenna includes an omnidirectional fiberglass antenna, pole-mounted single antenna arm	With 30-foot (914-cm) coaxial cable with N-type male connectors on both ends	903-002700-02
		With 50-foot (1524-cm) coaxial cable with N-type male connectors on both ends	903-002700-03
	890- to 960-MHz 10-dBi antenna includes omnidirectional Yagi antenna, pole-mounted single antenna arm	With 30-foot (914-cm) coaxial cable with N-type male connectors on both ends (customer to provide 1.375-inch OD pipe for Antenna)	903-002701-01
		With 50-foot (1524-cm) coaxial cable with N-type male connectors on both ends (customer to provide 1.375-inch OD pipe for Antenna)	903-002701-02
	403- to 470-MHz 2-dBi antenna includes omnidirectional antenna, pole mounting and bracket BM-1009, 2-shrink tubing, grounding kits for LMR-400, a weather-resistant cable tie	With 40-foot (1219-cm) coaxial cable with N-type male connector on both ends	903-002702-02
		With 60-foot (1829-cm) coaxial cable with N-type male connector on both ends	903-002702-01
Local antenna	403- to 470-MHz 2-dBi antenna includes omnidirectional antenna with N-male connector	904-002450-02	

**Table 12. Communication Gateway—Accessories**

Item		Catalog Number
Backup battery system kit <sup>①</sup>		903-002460-01
3-prong (U.S.) ac power cable for gateway indoor programming use	6 feet (183 cm)	007-002101-01
	15 feet (457 cm)	007-002101-02

<sup>①</sup> Can be ordered later by customers who initially choose not to have a backup battery. It can be installed by customer in the field.

**Overhead—Pole-Top Style**  
 15-kV (110-kV BIL) Models

Dimensions in inches to nearest 1/8-inch (3.2 mm)

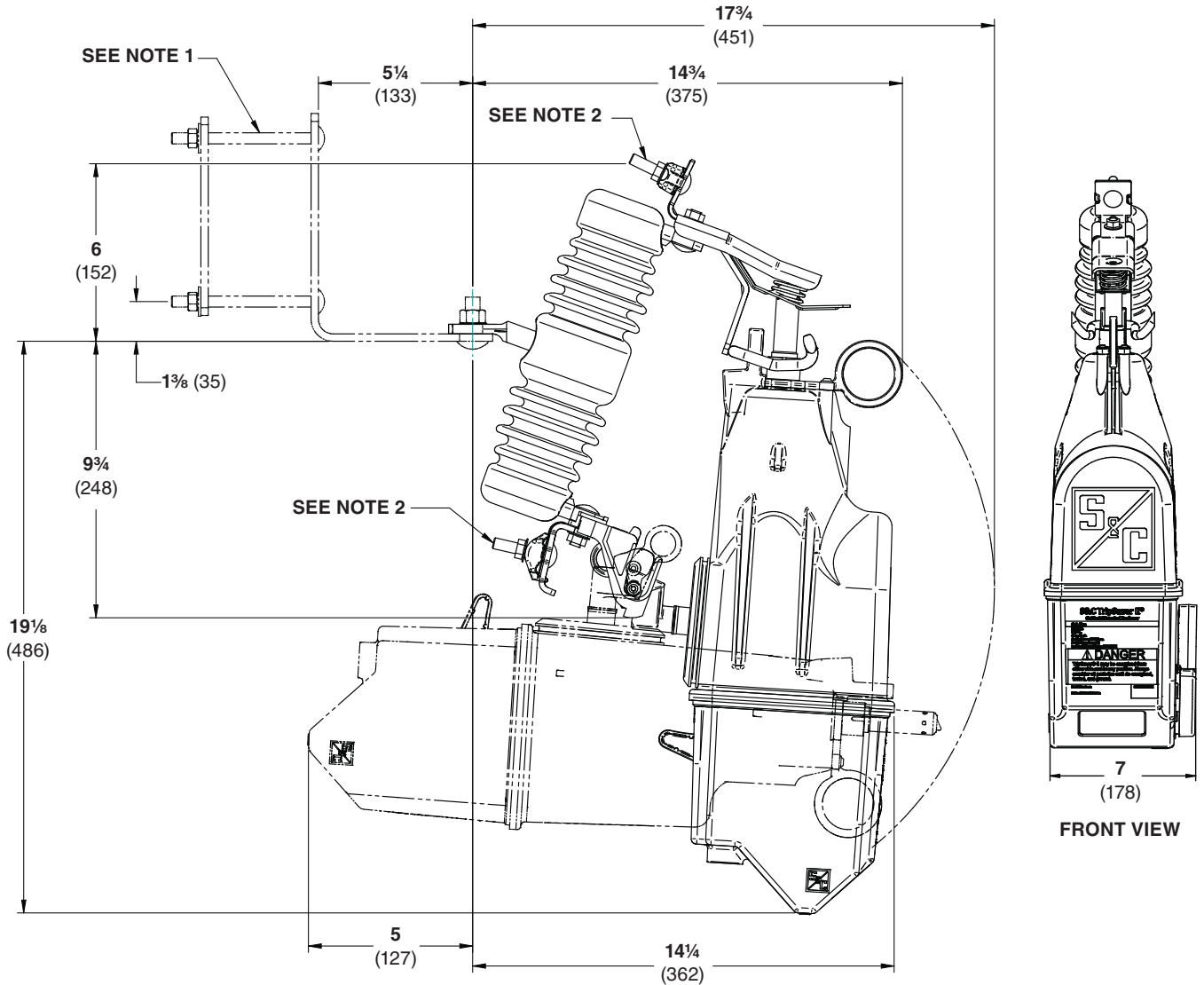

**NOTES:**

1. Mounting bracket, adjustable for 3-inch×4-inch (76-mm×102-mm) to 4-inch×5-inch (102-mm×127-mm) crossarm, furnished only when catalog number suffix “-B” or “-C” is specified.
2. Includes two parallel-groove connectors accommodating No. 6 solid (13.3 mm<sup>2</sup>) through No. 2 stranded (44.4 mm<sup>2</sup>) copper or aluminum in one groove, and No. 2 solid (33.6 mm<sup>2</sup>) through 250 kc mil (168 mm<sup>2</sup>) stranded copper or aluminum or 4/0 ACSR (161 mm<sup>2</sup>) in the other groove.
3. Dimension shown is for catalog number suffix “-B” (S&C extended bracket). Dimension is 2 5/8 inches (66.7 mm) for catalog number suffix “-C” (NEMA “B” bracket).
4. Weight 23 lbs. (10.4 kg).

# TripSaver® II Cutout-Mounted Recloser

## Overhead—Pole-Top Style

25-kV (125-kV and 150-kV BIL) Models

Dimensions in inches to nearest 1/8-inch (3.2 mm)

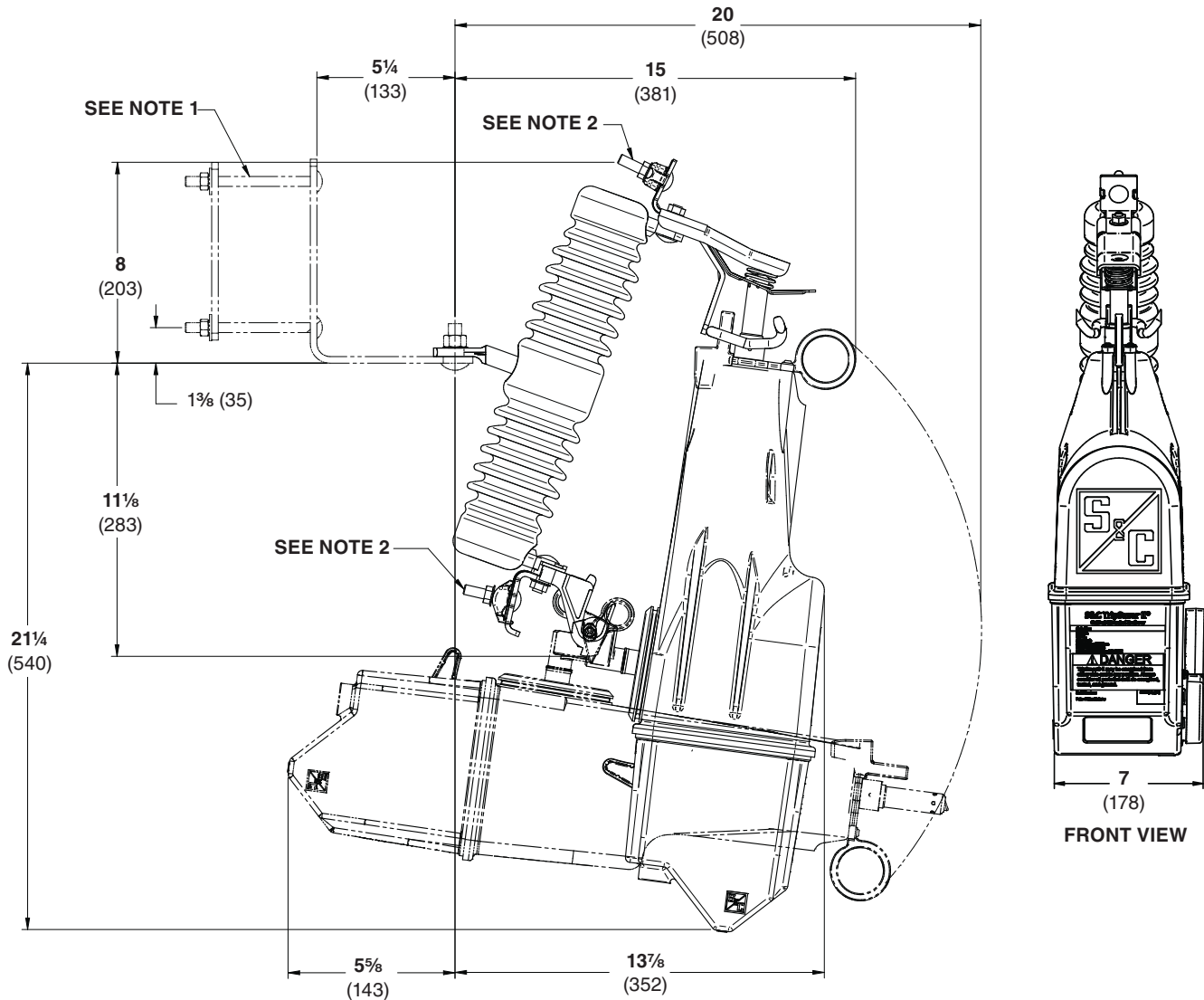

### NOTES:

1. Mounting bracket, adjustable for 3-inch×4-inch (76-mm×102-mm) to 4-inch×5-inch (102-mm×127-mm) crossarm, furnished only when catalog number suffix "-B" or "-C" is specified.
2. Includes two parallel-groove connectors accommodating No. 6 solid (13.3 mm<sup>2</sup>) through No. 2 stranded (44.4 mm<sup>2</sup>) copper or aluminum in one groove, and No. 2 solid (33.6 mm<sup>2</sup>) through 250 kc mil (168 mm<sup>2</sup>) stranded copper or aluminum or 4/0 ACSR (161 mm<sup>2</sup>) in the other groove.
3. Dimension shown is for catalog number suffix "-B" (S&C extended bracket). Dimension is 2 5/8 inches (66.7 mm) for catalog number suffix "-C" (NEMA "B" bracket).
4. Weight 25 lbs. (11.3 kg).

TripSaver II Communication Gateway

Dimensions in inches to nearest 1/8-inch (3.2 mm)

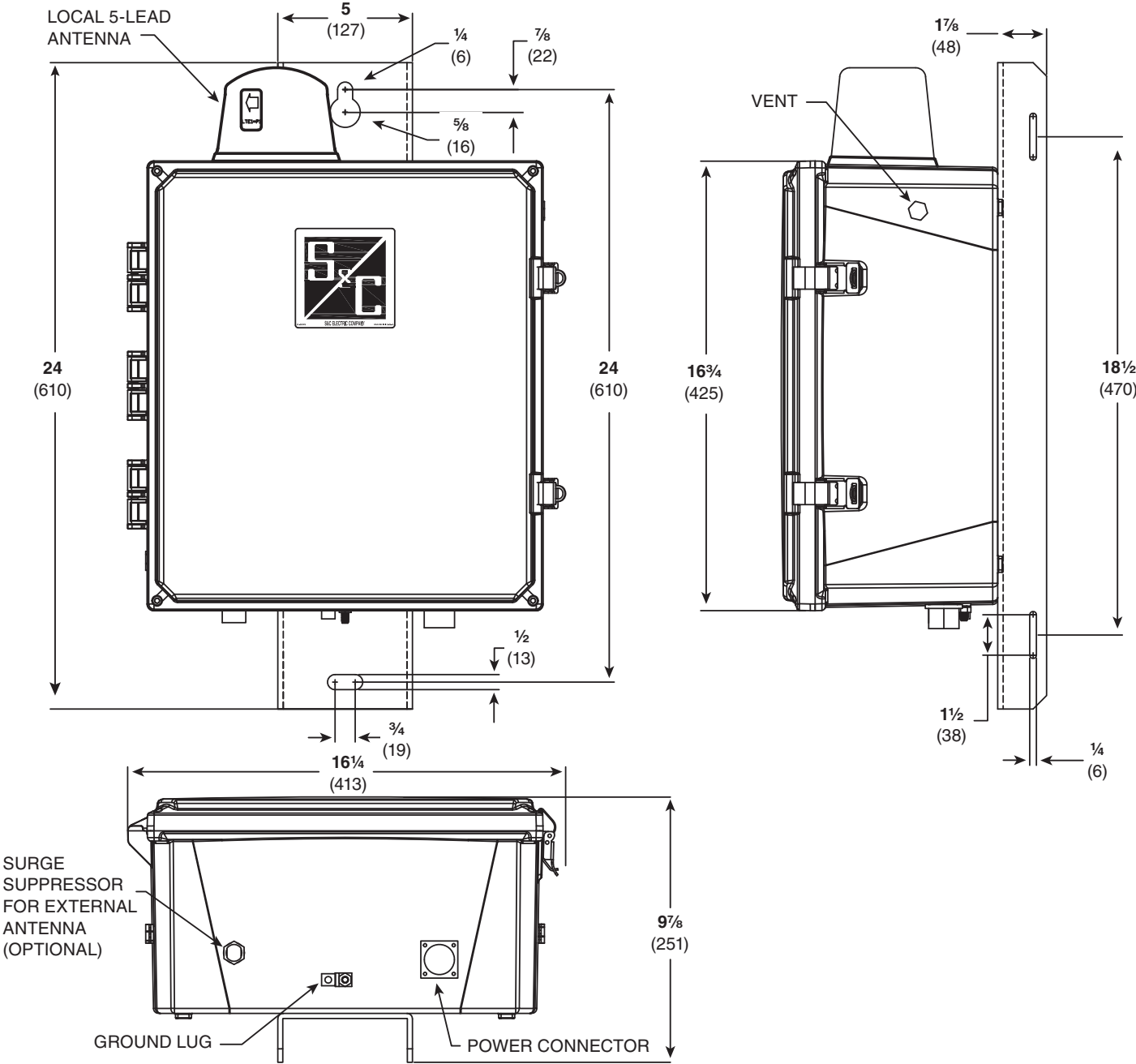

**NOTES:**  
Weight: 25 lbs. (11.3 kg).