



Vista 'Spinner' Type Flow Indicator

This sight flow indicator is ideal for you to visually check the flow, presence, colour and condition of a liquid, gas or condensate.

- ◆ High quality robust design
- ◆ Pressures up to 10 bar
- ◆ Temperatures up to 100°C
- ◆ Short lead times
- ◆ Designed and manufactured in the UK.



Application

The Vista 'Spinner' is a single sided gunmetal indicator that can be used on pipe sizes from 8mm to 25mm (1/4" to 1"). The spinner starts to rotate when flow starts and is clearly visible from distances. The design offers low pressure losses and is suitable for installation in both horizontal and vertical pipework.

Applications include:

- Pump, compressor and diesel engine protection
- Ensuring that flow of cooling water is maintained to specialised equipment
- Detecting changes in colour and condition of liquids during processing
- Indication of air entrainment
- Early warning of overheating, bearing or seal failure

Construction

The bodies are cast in high quality gunmetal

The glass dome is held in place by a brass clamp ring and sealed with a Viton O'ring.

The sight glasses are supplied with screwed connections to BSP parallel (other connections are available on request).

Quality

All Flowpoints indicators are manufactured to the highest standards.

The quality system is independently audited by BSI and certified to ISO 9001.

Materials of Construction

Body - Gunmetal BS1400 LG2
 Clamp Ring - De-zincified Brass
 Spinner - PPS Plastic (colour - fast yellow)
 Glass Dome - Moulded Annealed Borosilicate
 O'Ring - Viton
 Gasket - Klingersil C4400
 Fasteners - Stainless steel

Flow Requirements

Size (mm)	Minimum Flow (l/min)	Maximum Flow (l/min)	Pressure Drop - 2 m / sec (bar)
8	0.7	12	0.1
15	1.2	40	0.1
20	1.4	75	0.3
25	1.4	120	0.5

Dimensions and Weights

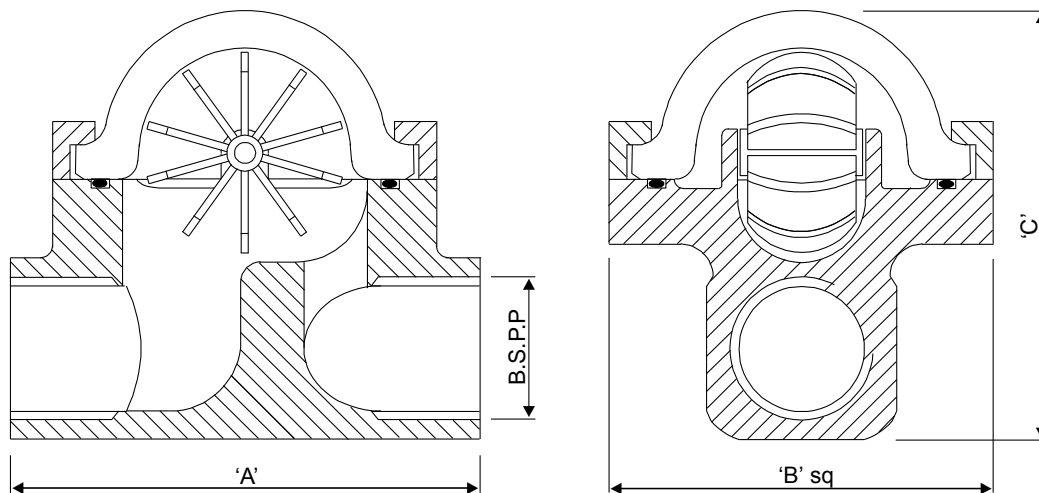

Bore Size mm (inch)	Weight (kg)	Overall Length 'A' (mm)	Width (Clamp) 'B' (mm)	Overall Height 'C' (mm)
8 (1/4)	0.7	76	60	65
15 (1/2)	0.7	76	60	65
20 (3/4)	1.5	89	60	85
25 (1)	1.3	89	60	85