

# C

Illustrated as drawing 1, when the liquid pass through main hole's plate, the pressure difference between front side and back side happens, there is a respondent function relation between the pressure difference and flow speed. Installing a small rotor flowmeter on the in-outlet of branch, i.e. to make that the flow volume through small rotor flowmeter is same to the volume through main pipe, therefore the flow volume's data in main pipe can be read through buoy position and scale on small rotor flowmeter.

The cut-off valve installed between measure pipe and indicator can make the flowmeter's take-down or repair conveniently when the main pipe is being in normal working situation.

- Temperature limit: Polyformaldehyde(POM): 0~100°C, SS304: 0~120°C
- Accuracy: ±2.5%
- Max. working pressure: 1.0MPa

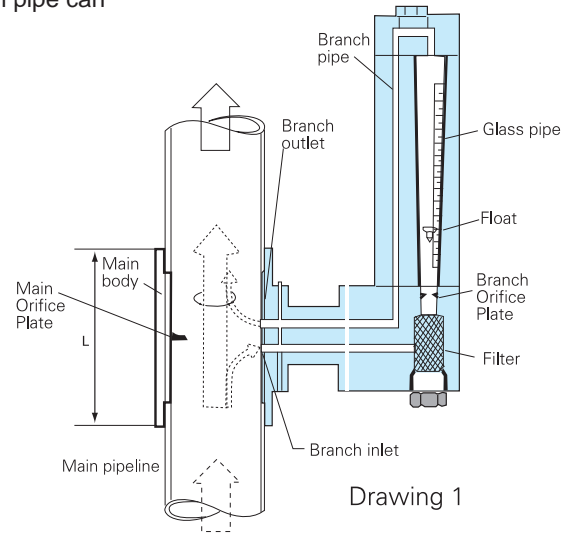

Drawing 1

### Specifications

DN(mm)	Size PSP	Measuring range	
		Water(m <sup>3</sup> /h)	Air(Nm <sup>3</sup> /h)
10	3/8"	0.1~0.5	0.8-4
15	1/2"	0.2~1	2-10
20	3/4"	0.5~2.5	5-25
25	1"	1~5	8-40
32	1-1/4"	1.4~7	12-60
40	1-1/2"	2~10	18-90
50	2"	4~20	35-175
65	2-1/2"	7~35	60-300
80	3"	10~50	80-400
100	4"	18~90	160-800
125	5"	25~125	250-1250
150	6"	40~200	350-1700
200	8"	70~350	600-2800
250	10"	100~500	900-5000
300	12"	180~900	1600-7800
350	14"	200~1000	2000-9500
400	16"	300~1500	3000-14500
450	18"	400~2000	4000-19000
500	20"	500~2500	5000-24000
600	24"	600~3000	6000-30000

\* Note: We need detail datas of working pressure, working temperature, density for gas medium.

### Flow direction

The product can be changed different directions illustrated as drawing 3, the flow direction can divide as: bottom-top, left-right, right-left and top-bottom. It is easy to change flow direction on the spot.  
Attention: special flow volume' specification can be customized according to technical data provided by customers.

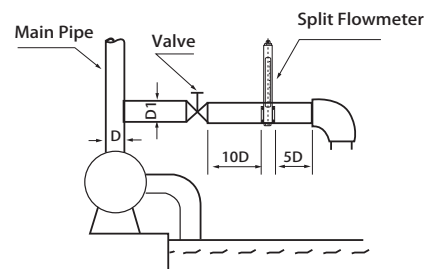
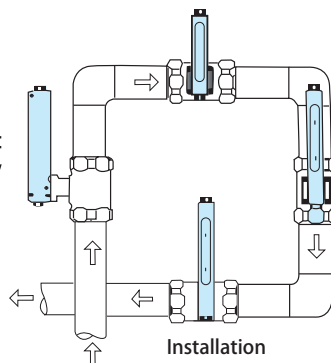

For purpose to measure the flow speed precisely, recommend to use below straight pipe diameter:

# KF600 series





## Orifice Plate Flowmeters

For purpose to measure the flow speed precisely, recommend to use below straight pipe diameter:

**D is main pipeline diameter**

	90°C Elbow Pipe	Opening Valve
Up straight pipe diameter	10D	12D
Down straight pipe diameter	5D	5D

### Flow direction

Measure gas	Indicator(for liquids)
Center → 	Top → 
Metal material	PVC material
Top → 	Top → 

### AT thread type

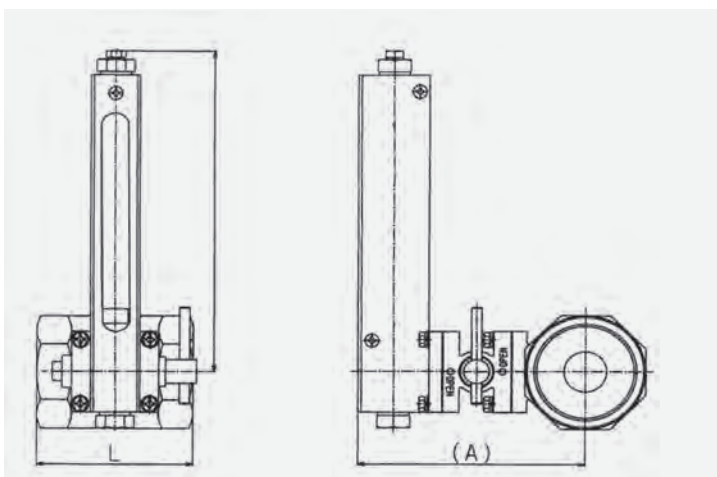
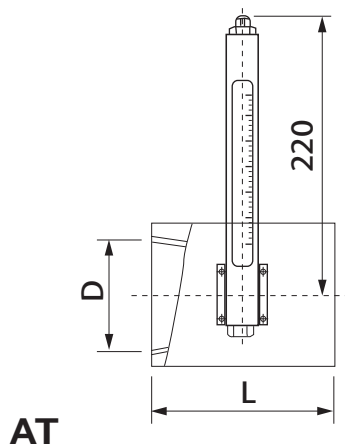

### AT External dimensions Unit:(mm)

DN	Pipeline Material SS304		
	L	*A	Weight(KG)
10	70		0.5
15	70		0.43
20	70		1.01
25	70		1.2
32	70	120	1.4
40	84	120	1.6
50	80	130	2.3
65	80	140	3.1
80	90	145	4.3
100	100	160	6

A : if without valve, then A's length need reduce 52mm

D

AC: Clamp type

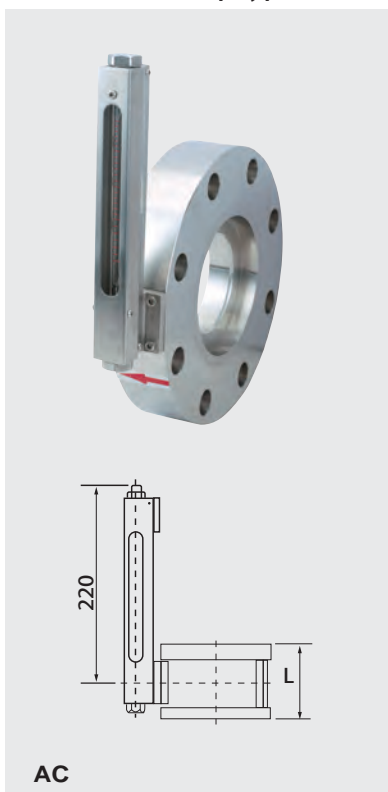

(1) Material (SS304, polyformaldehyde)

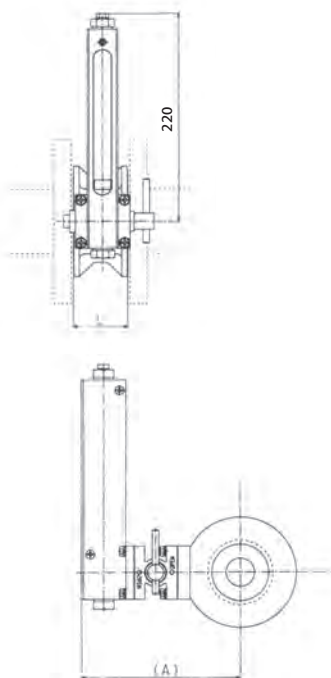

AC External dimensions Unit: (mm)

DN	L	*A	POM(KG)	304(KG)
10	50	137	0.3	2.5
15	50	140	0.4	2.7
20	50	145	0.52	2.8
25	50	150	0.7	3
32	50	165	0.95	4
40	50	170	1.1	5.4
50	50	178	1.3	6.1
65	50	190	1.6	7.3
80	50	195	1.75	9.3
100	50	200	2.0	10.3
125	50	220	2.5	11.3
150	50	240	3.1	14
200	50	270	4.2	15
250	50	295	5.1	16
300	50	320	6.0	17.5
350	65	350	7.0	19
400	65	380	8.0	21
450	65	405	9	23
500	65	432	10	25
600	65	492	11	28

A : if without valve, then A's length need reduce 52mm

AF: Flange type

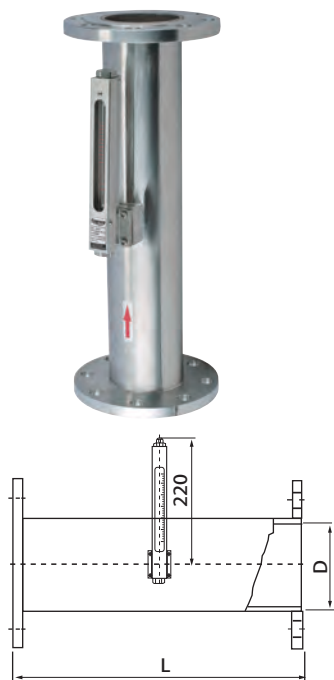

(1) Material (SS304, polyformaldehyde)

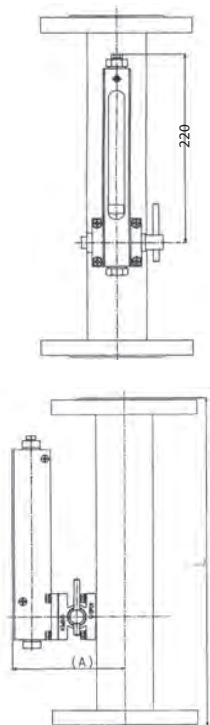

AF External dimensions Unit: (mm)

DN	Material of measure pipe(304SS)		
	L	*A	KG
10	520	-	-
15	520	-	-
20	520	-	-
25	520	-	-
32	520	-	-
40	520	138	7.1
50	520	143	8.5
65	540	150	11.4
80	540	157	12
100	540	168	15.5
125	540	180	20
150	540	193	27
200	540	218	35
250	540	242	50
300	540	268	61
350	540	460	74
400	540	510	93
450	540	560	115
500	540	610	130
600	540	710	170

A : if without valve, then A's length need reduce 52mm

L 200mm is optional as special (DN10mm-80mm)  
L 300mm(DN100mm-600mm)is optional as special

# KF600 series

## Orifice Plate Flowmeters

AD: Remote type

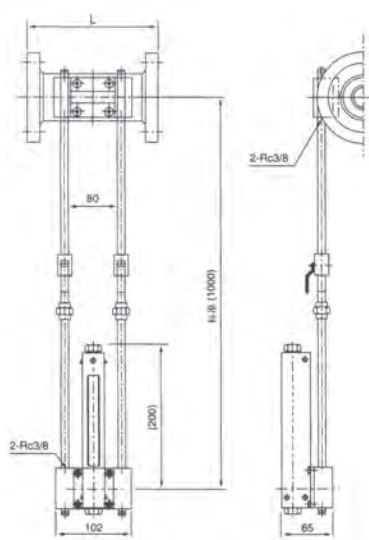

Local indicator 1 material (SS304)

With alarm switch indicator 3 material (SS304)

Valve material (SS304)

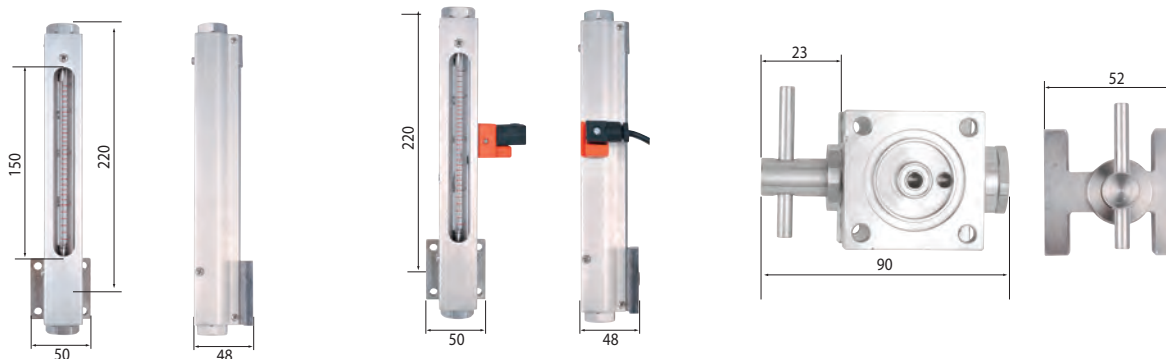

KF600

How to order

