

ELECTROMAGNETIC FLOW METER



01 MAGNETIC FLOW METER WORKING PRINCIPLE

Magnetic flow meters use the principle of Faraday's Law of Electromagnetic Induction to measure the flow rate of liquid in a pipe. In the magnetic flowmeter pipe parts, a magnetic field is generated, and channeled into the liquid flowing through the pipe.

Faraday's Law states that the voltage generated is proportional to the movement of the flowing liquid. A conductor moving through a magnetic field produces an electric signal within the conductor. And the signal is proportional to the velocity of the water moving through the field.

As fluid flows through the magnetic field, conductive particles in the fluid create changes. This variation is used to measure and calculate the velocity of water flow through the pipe. When the fluid moves faster, more voltage is generated. The electronic transmitter processes the voltage signal to determine liquid flow.

02 APPLICATIONS

- **Water water industry:** Transport networks sewage treatment plants, sludges
- **Chemical industry:** Acids alkalis, dosing applications, abrasive or corrosive mediums
- **Metal & mining industry:** Mediums with a high solid content, like ore or excavator mud
- **Water industry:** Revenue metering, district metering water abstraction, leakage detection
- **Pulp & paper industry:** Pulp, pastes, sludges & other caustic mediums, liquor, additives, bleaches, colourants
- **Food & beverage industry:** Mixing, dosing and filling of drinks under hygienic conditions filling systems applications



03 FEATURES

- High accuracy & wide flow range measurement
- 99.999% pure copper for oil
- No mechanically moving parts
- IP68 proof, maximum 3 meter immersion in water
- Drinking water approvals
- FDA approvals
- Bi-directional measure
- Wide choice of materials for housing and flanges including SS304 and SS316
- Advanced wire-winding technology, no drift zero point
- Robust, fully welded and potted construction
- In house wet calibration for all diameters (up to DN3000)
- Three electrodes
- ≥ 3 mm thickness PTFE liner, durable service life

ELECTROMAGNETIC FLOW METER

04 INSTRUMENT CONNECTION

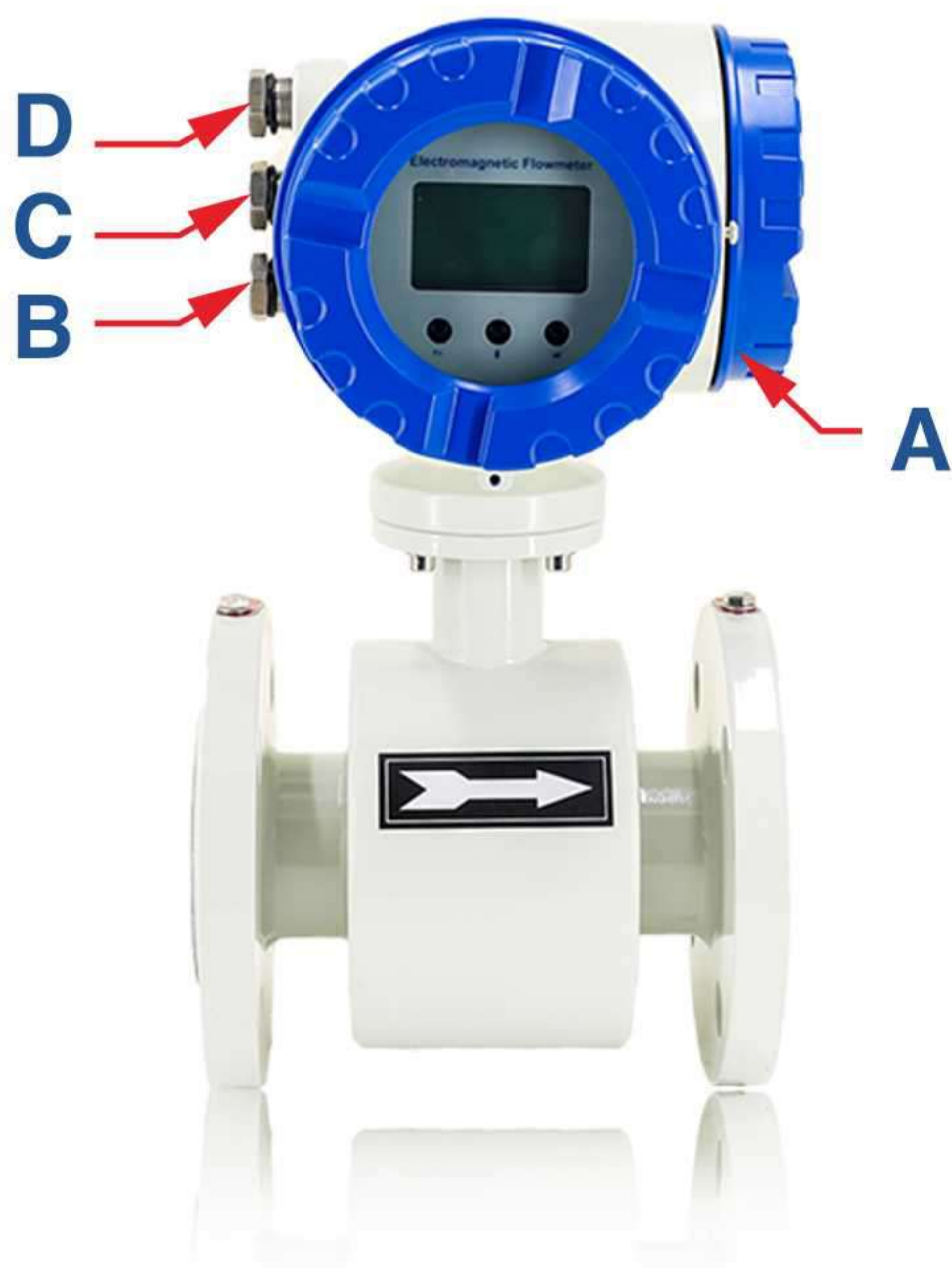

Converter Connection:

- A. Wiring diagram in the modified wiring cavity
- B. Power cable
- C. Signal cable or fieldbus cable
- D. Optional

05 WIRING

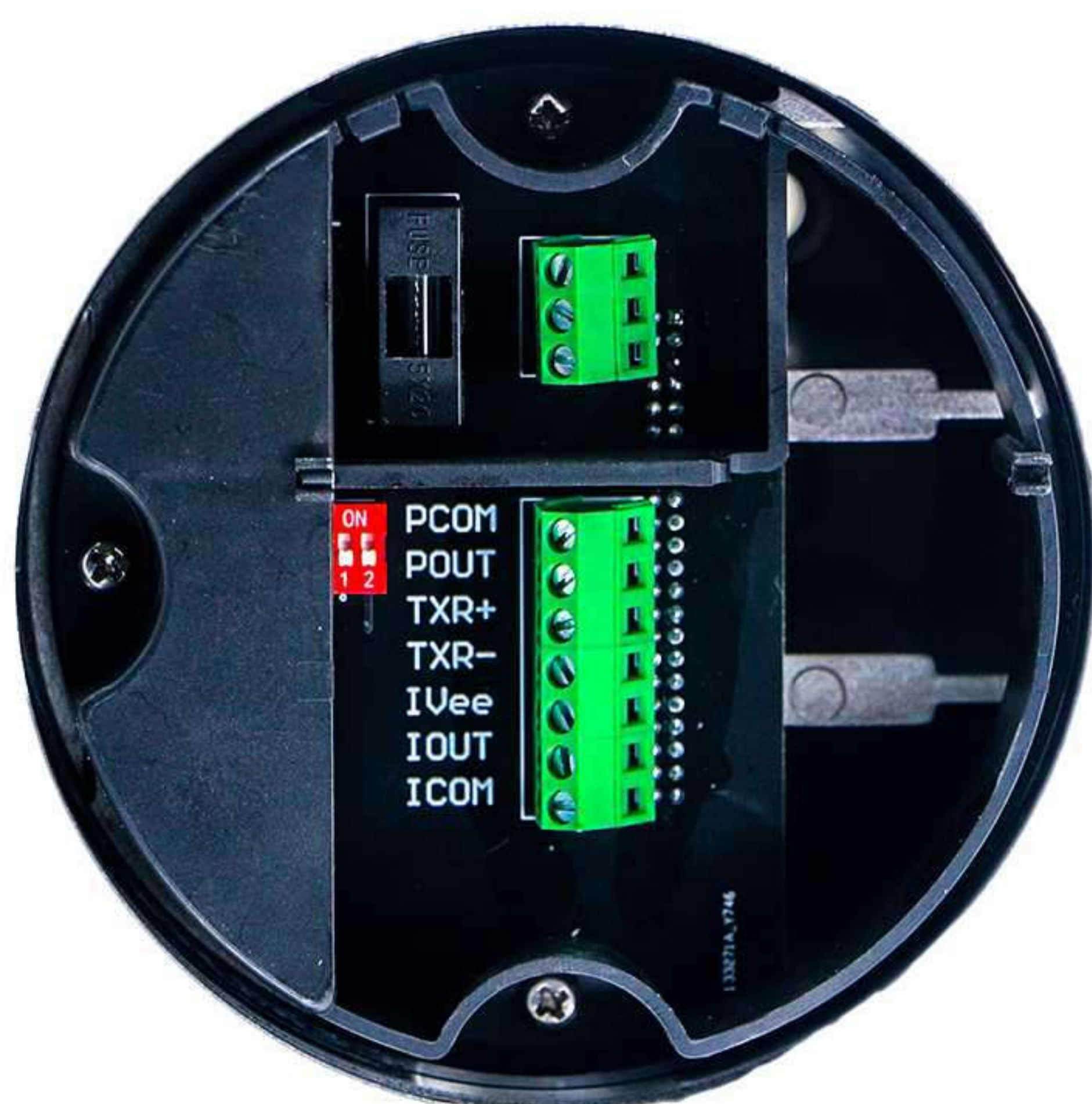

Sensor	SGND	Signal ground
	SIG 2	Signal 2
	EXT-	Field current -
Current output	IOUT+	Current output +
	ICOM-	Current common -
Pulse or frequency output	POUT+	Frequency (pulse) output (+)
	PCOM-	Frequency (pulse) output (-)
Digital output	DOUT+	Digital output (+)
	DCOM-	Digital output (-)
Communication interface	TXR+	Communications output (RS485+)
	TXR-	Communications output (RS485-)

ELECTROMAGNETIC FLOW METER

06 INSTALLATION DIMENSIONS

Diameter (mm)	Flange					Bolt	n*d (mm)
	L (mm)	D (mm)	K (mm)	H (mm)			
15	200	95	65	301.5	M12*50	4*φ14	
20	200	105	75	308.5	M12*50	4*φ14	
25	200	115	85	318	M12*50	4*φ14	
32	200	140	100	333	M16*70	4*φ18	
40	200	150	110	339.5	M16*70	4*φ18	
50	200	165	125	353	M16*70	4*φ18	
65	200	185	145	368.5	M16*70	4*φ18	
80	200	200	160	383.5	M16*70	8*φ18	
100	250	220	180	404	M16*70	8*φ18	
125	250	250	210	432	M16*70	8*φ18	
150	300	285	240	458.5	M20*90	8*φ22	
200	350	340	295	515.5	M20*90	12*φ22	
250	450	405	355	584	M24*110	12*φ26	
300	500	460	410	626.5	M24*110	12*φ26	
350	550	520	470	681	M24*110	16*φ26	
400	600	580	525	741	M27*130	16*φ30	
450	600	640	585	791	M27*130	20*φ30	
500	600	715	650	856.5	M30*140	20*φ33	
600	600	840	770	972	M33*170	20*φ36	
700	700	910	840	1058	M33*180	24*φ36	
800	800	1025	950	1166.5	M36*210	24*φ39	
900	900	1125	1050	1266.5	M36*220	28*φ39	
1000	1000	1255	1170	1381.5	M39*250	28*φ42	

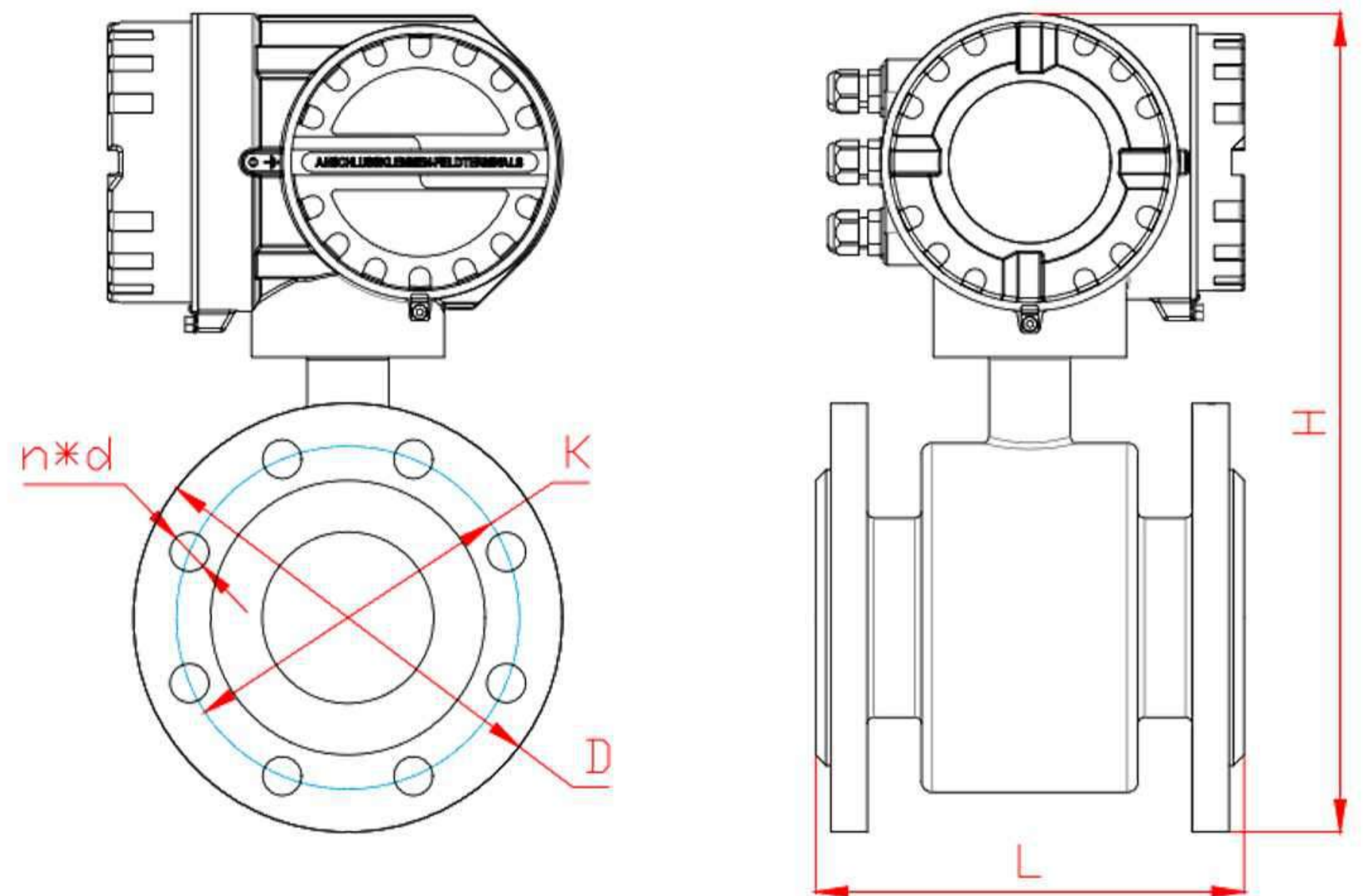

07 MEASUREMENT METHOD



ELECTROMAGNETIC FLOW METER

08 MORE PRODUCTS



A TYPE(ATEX)



B TYPE



REMOTE TYPE (Y TYPE)



**SANITARY MAGNETIC
FLOW METER**



**INSERTION MAGNETIC
FLOW METER**



**MINI MAGNETIC
FLOW METER**

ELECTROMAGNETIC FLOW METER

09 TECHNICAL DATA

Diameter	PTFE: DN2.5-DN1000
	Rubber: DN50-DN3000
Flow Direction	Forward; Reverse
Repeatability Error	±0.1%
Accuracy	±0.5% of rate; ±0.2% of rate
Medium Temperature	Rubber liner: -20...+60°C
	PTFE liner: -20...+120 °C
	PFA: -20...+180°C
	Ceramic: -20...+ 180 °C
Velocity	0.3-10m/s
Ambient Temperature	-20...+60 °C
Relative Humidity	5%~95%
Power Consumption	<20W
Protection	IP 65; IP 68 (Remote Type)

010 MAIN PERFORMANCES OF THE ELECTRODE MATERIALS

Electrode Material	Application
SS316L	Applicable in water, sewage and low corrosive medium; Widely used in industries of petrol, chemistry, carbamide etc.
Hastelloy B	Having strong resistance to hydrochloric acid of any consistence which is below boiling point. Resistable against vitriol, phosphate, hydrofluoric acid, organic acid etc which are oxidable acid, alkali and non-oxidable salt.
Hastelloy C	Be resistant to oxidable acid such as nitric acid, mixed acid as well as oxidable salt such as Fe ⁺⁺⁺ ,Cu ⁺⁺ and sea water
Titanium	Applicable in seawater, and kinds of chloride, hypochlorite salt, oxidable acid (including fuming nitric acid), organic acid, alkali etc. Not resistant to a pure reducing acid (such as sulphuric acid. hydrochloric acid) corrosion. But if acid contains antioxidant (such as Fe ⁺⁺⁺ ,Cu ⁺⁺)is greatly reduce corrosion
Tantalum	Having strong resistance to corrosive mediums that is similar with glass. Almost applicable in all chemicals mediums except for hydrofluoric acid, oleum and alkali
Platinum-iridium	Almost be applicable in all chemical mediums except fortis, ammonium salt
Ceramic	Resistant to vacuum, corrosion, wear, and extreme temperatures, widely used in chemical industry, papermaking and pulp, and water and wastewater treatment.

ELECTROMAGNETIC FLOW METER

011 TECHNICAL DATA

Diameter		Flow Rate (m ³ /h)		
		V=0.3m/s	V=6m/s	V=10m/s
mm	Inch	Min	Calibrated	Max
2.5	1/10"	0.0053	0.106	0.177
4	1/8"	0.014	0.271	0.452
6	1/4"	0.03	0.6	1
10	3/8"	0.1	1.7	3
15	1/2"	0.2	4	6
20	3/4"	0.3	7	11
25	1"	0.5	11	18
32	1-1/4"	0.9	17	29
40	1-1/2"	1	27	45
50	2"	2	42	71
65	2-1/2"	4	72	120
80	3"	5	109	181
100	4"	8	170	283
125	5"	13	265	442
150	6"	20	382	636
200	8"	34	679	1131
250	10"	53	1060	1767
300	12"	76	1527	2545
350	14"	104	2078	3465
400	16"	136	2714	4524
450	18"	171	3435	5726
500	20"	212	4241	7069
600	24"	305	6107	10179
700	28"	415	8310	13850
800	32"	542	10860	18100
900	36"	662	13740	22900
1000	40"	848	16962	28270

ELECTROMAGNETIC FLOW METER

012 MODEL SELECTION

Model	Suffix Code													Description
LDG-	①	②	③	④	⑤	⑥	-⑦	⑧	⑨	⑩	⑪	⑫	⑬	Electromagnetic Flow Meter
Type	B													B type (Compact structure)
	Y													Y type (Remote structure)
	W													W803 type (Battery supply)
	A													ATEX Type (Ex-proof)
	H													HY900(For sludge)
Diameter	XXX													Stand for diameter 0006: DN6; 0015: DN15 0100: DN100; 2200: DN2200
Structure		S												Compact Type with local display
		L												Remote Type; 10 meters cable default
Electrode Material			M											SS316L
			T											Titanium
			D											Tantalum
			H											Hastelloy C
			P											Platinum-Iridium
			C											Ceramic
Signal Output					0									No Output
					1									4-20mA / Pulse
Liner Material						X								Rubber (DN40-DN2000)
						F								PTFE (DN2.5-DN2000)
						A								PFA (DN2.5-DN500)
						C								Ceramic (DN10-DN600)
						P								Polyurethane (DN15-DN500)
Power Supply							-0							110-240V AC
							-1							24V DC (20-36V DC)
							-2							Battery Power Supply
Communication								0						No Communication
								1						Modbus RS485
								2						HART
								3						GPRS
								4						Others (Profibus DP, Profibus PA, BACnet / IP, etc)
Sensor Grounding									0					No Grounding
									1					Grounding Ring
									2					Grounding Electrode
Connection										DXX				D16: DIN PN16 Flange ; D25: DIN PN25 Flange...
										AXX				A15: ANSI150# Flange; A30: ANSI 300# Flange...
										JXX				J10: JIS 10K Flange; J20: JIS 20K Flange...
										XXX				On request
Body Material											CS			Carbon Steel
											S4			Stainless Steel 304
											S6			Stainless Steel 316
Cable												0		Default
												XX		Optional
Accuracy													5	± 0.5%
													2	± 0.2%

ELECTROMAGNETIC FLOW METER

013 INSTALLATION

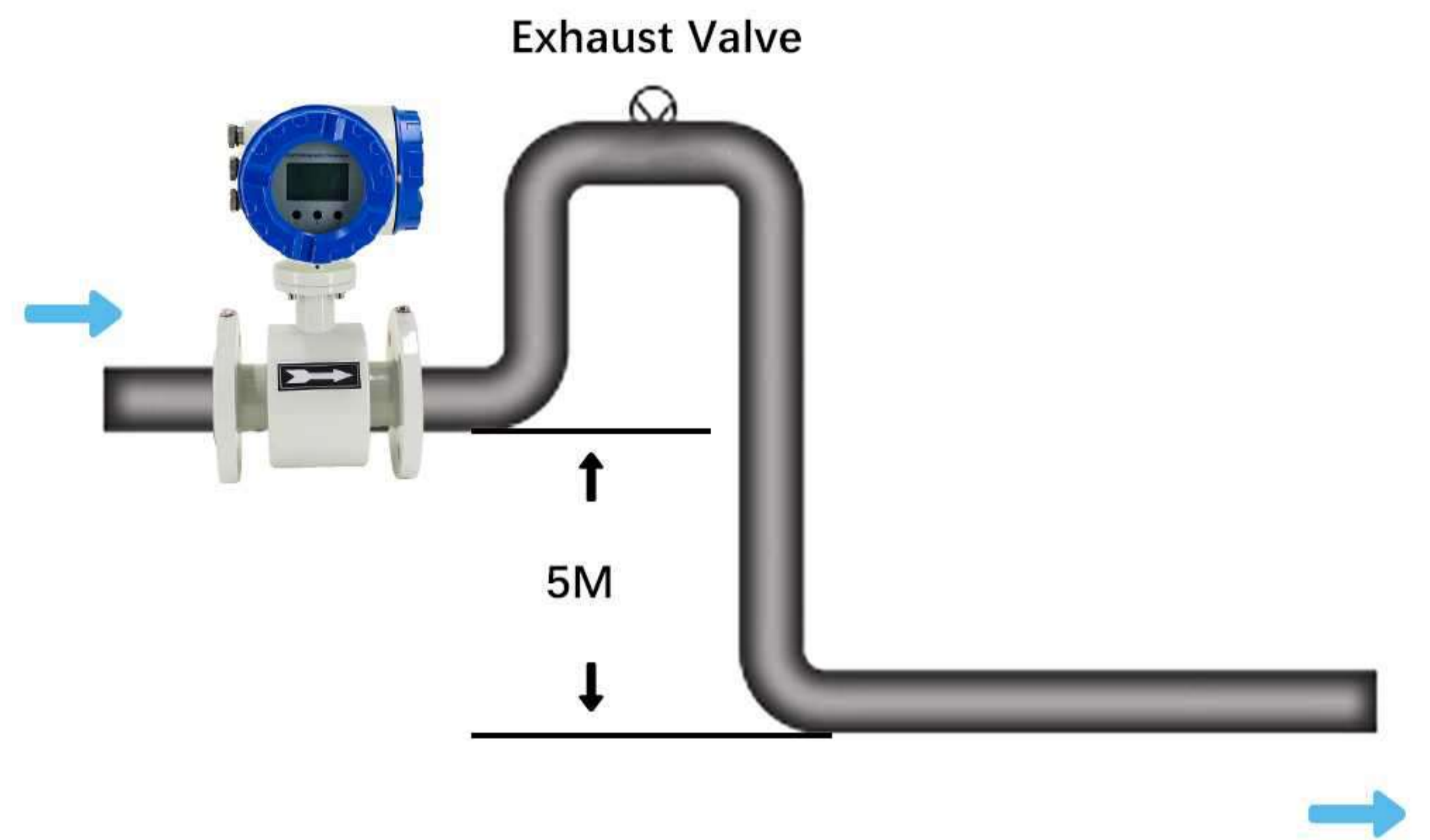
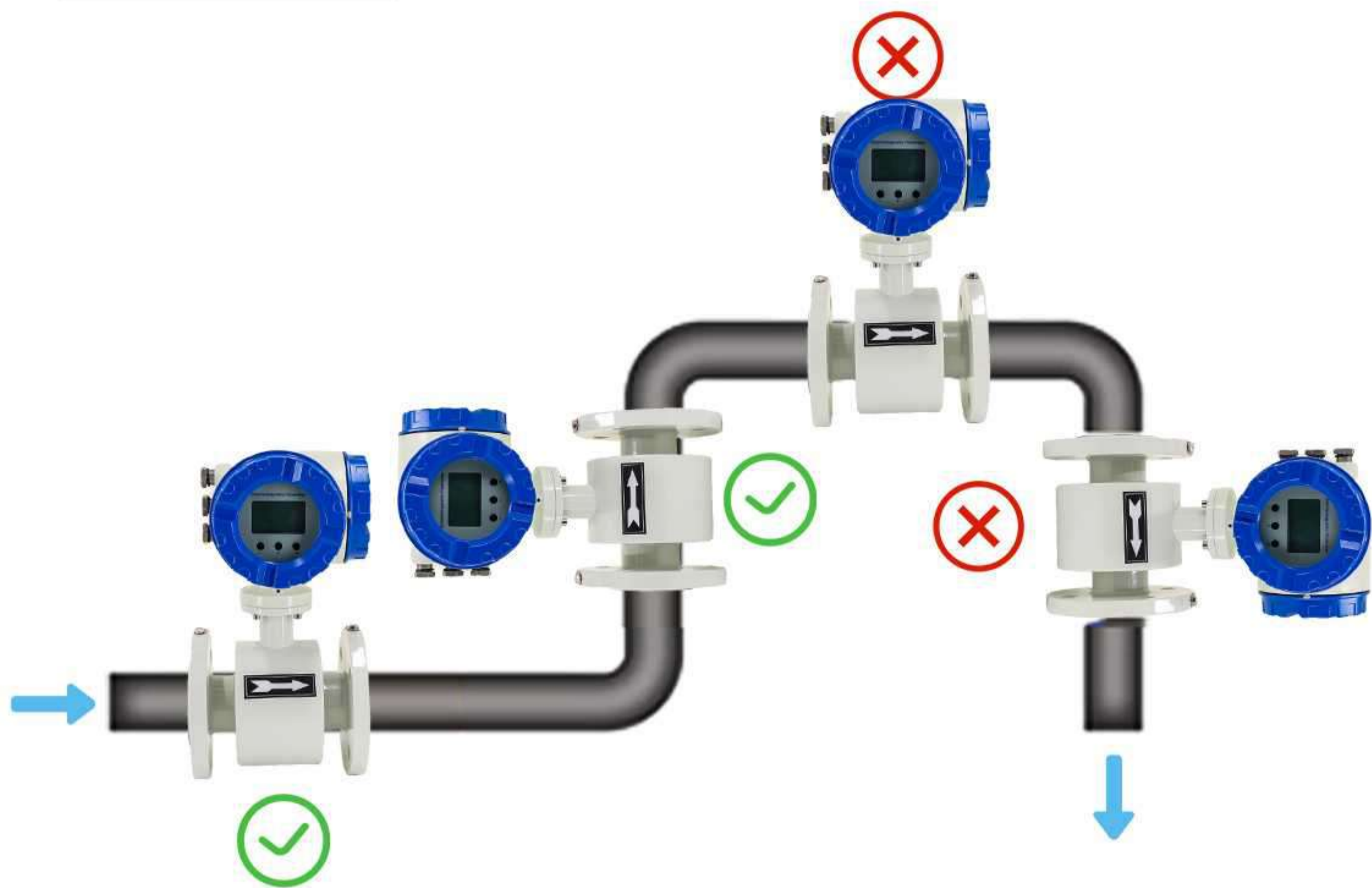

The flow meter should be installed at a lower level and vertically upwards of the horizontal pipe. Avoid installation at the highest and vertically downwards point of the pipe.

When drop is more than 5m, install exhaust valve at the downstream.



Install at the lowest point when used in poen drain pipe.

Need 10D of upstreat and 5D of downsteat



Don't install it at the entrance of pump, install it at the exit of pump.

Install at the rising direction