

วาล์วระบายนิรภัย

Model: SF – 13, SF-13L, SF-14, SF-14L (แบบคว้านรูเต็ม)

(เหมาะสำหรับอุปกรณ์รับความดัน, หม้อต้มไอน้ำ และอื่นๆ (1.0 MPa)

มีทั้งแบบมีด้าม และไม่มีด้ามโยก

SF-13 , SF-13L



SF-14 , SF-14L



Specifications

Model name	SF-13	SF-13L	SF-14	SF-14L
Code name	SF13-G □	SF13L-G □	SF14-G □	SF14L-G □
	Code No. of pressure division is required in □			
Cap type	With lever		Without lever	
Size	25 – 150 (1"-6")			
Applicable fluid	Air	Steam	Air, gases & Liquids	Steam
Fluid temperature	-5 - 220 °C		-5 - 184 °C	
Set pressure range	0.1 – 1.0 MPa			
End connection	Inlet: Flanged JIS10KFF (Thickness is based on table of DIMENSIONS) ^{*2} Outlet: Flanged JIS10KFF			
Materials	Body (Cast iron), Disc & Seat ring (Stainless Steel ^{*1})			
Valve body pressure test	Hydraulic 1.5 MPa			

*1. Applicable temperature Max.220°C is available upon your request.

*2. Flanged codes JIS B8210 for inlet is also available upon your request.

*3. The valve for steam has spill valve disc.

Dimensions

● CONSTRUCTION OF SF-13L, 14L VALVE PART

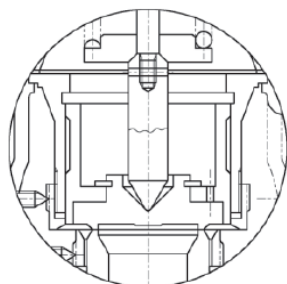

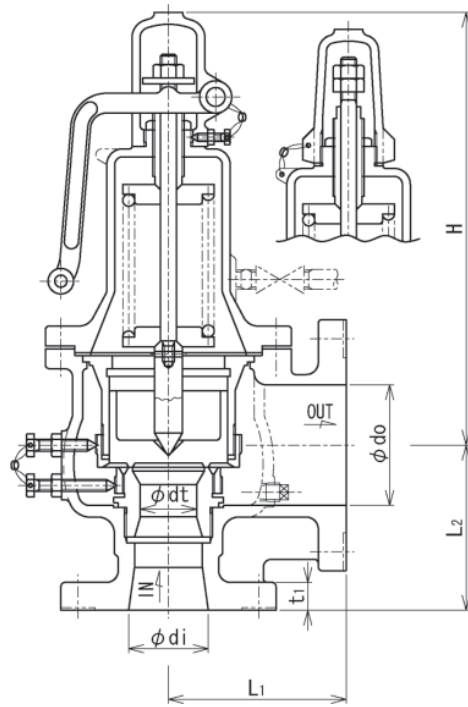

Depending on nominal diameter, the structure of the valve may be different from what is shown in the drawing

Size Inlet x Throat dia. x Outlet	Seat opening dia. D	Throat dia.	Throat area a(mm ²)	Lift l	Face to Face		Height H		Thickness of flange t	Mass (Kg)	
					L ₁	L ₂	SF-13,13L Type	SF-14,14L Type		SF-13,13L Type	SF-14,14L Type
DI x dt x do											
25(1")x19 x40(1 1/2")	22	19	283.3	5.0	105	95	226	227	22	11	11
40(1 1/2")x25x85(2 1/2") 30	35	25 30	490.6 706.5	6.5 7.5	125	120	280	281	24	20	19
50(2")x34x80(3") 38	45	34 38	907.4 1133.5	8.5 9.5	135	125	341	342	26	26	26
65(2 1/2")x43x100(4") 49	58	43 49	1451.4 1884.7	11.0 12.5	155	140	396	397	28	41	40
80(3")x55x125(5") 61	71	55 61	2374.6 2920.9	14.0 15.5	175	160	480	481	30	61	58
100(4")x69x150(6") 76	88	69 76	3737.3 4534.1	17.5 19.0	205	180	553	554	32	91	91
125(5")x86x200(8") 95	111	86 95	5805.8 7084.6	21.5 24.0	225	210	686	687	34	147	145
150 (6")x105x200(8") 115	134	105 115	8654.6 10381.8	26.5 29.0	255	220	813	815	36	226	220

Pressure Division (MPa)

Code No.	Pressure division
1	0.1
2	Over 0.1-0.12
3	Over 0.12-0.15
4	Over 0.15-0.18
5	Over 0.18-0.21
6	Over 0.21-0.25
7	Over 0.25-0.3
8	Over 0.3-0.36
9	Over 0.36-0.43
A	Over 0.43-0.5
B	Over 0.5-0.65
C	Over 0.65-0.8
D	Over 0.8-1.0