

**ประตูน้ำทองเหลือง: Model 209A ( ประตูน้ำทองเหลือง คลาส 150 ปอนด์ )**

เกลียวใน, ก้านยึดขึ้นลงตามการหมุน, ฝาครอบเกลียว

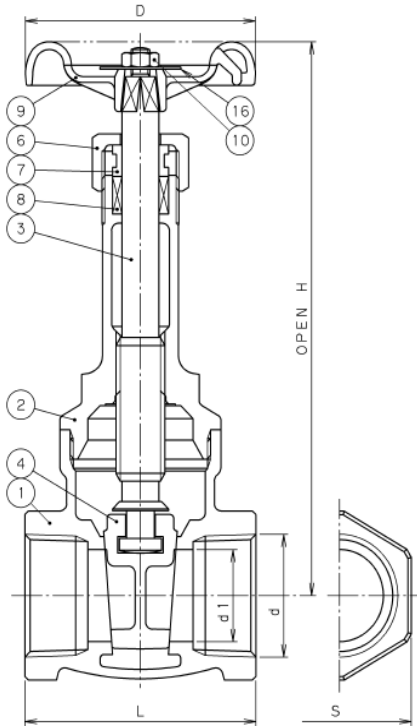

**ชิ้นส่วนและวัสดุที่ใช้**

No.	Name of parts	ASTM Specification		
1	Body	Cast bronze	ASTM B62	
2	Bonnet	Cast bronze	ASTM B62	
3	Stem	Cast bronze	ASTM B62	
4	Disc	Cast bronze	ASTM B62	
6	Packing nut	1/2 - 2	Forged brass	ASTM B283
7	Gland		Brass rod	ASTM B16
8	Gland packing		Aramid fibers graphite	
9	Handwheel	1/2 - 2	Aluminum die cast	ASTM B85
10	Wheel nut		Brass rod	ASTM B16
16	Name plate		Aluminum plate	

**ขนาด**

Size Mark	1/2	3/4	1	1 1/4	1 1/2	2
	15	20	25	32	40	50
H	51	56	66	68	74	84
G	137	157	180	216	257	295
L	55	70	70	80	90	100
D	28	34	41	52	57	70

## น้ำหนัก

Kgs	0.42	0.64	0.94	1.66	1.83	2.72
-----	------	------	------	------	------	------

## แรงดัน

Working pressures Non-Shock	
Saturated steam pressure	Water, Oil, Gas
1.03 MPa	2.07 MPa
150 psi	300 psi

KRUNG THAI EQUIPMENT CO., LTD.