

## Bronze Check Valves : Model 236A

Swing type, Y-pattern, screwed cap, integral disc, screwed ends.

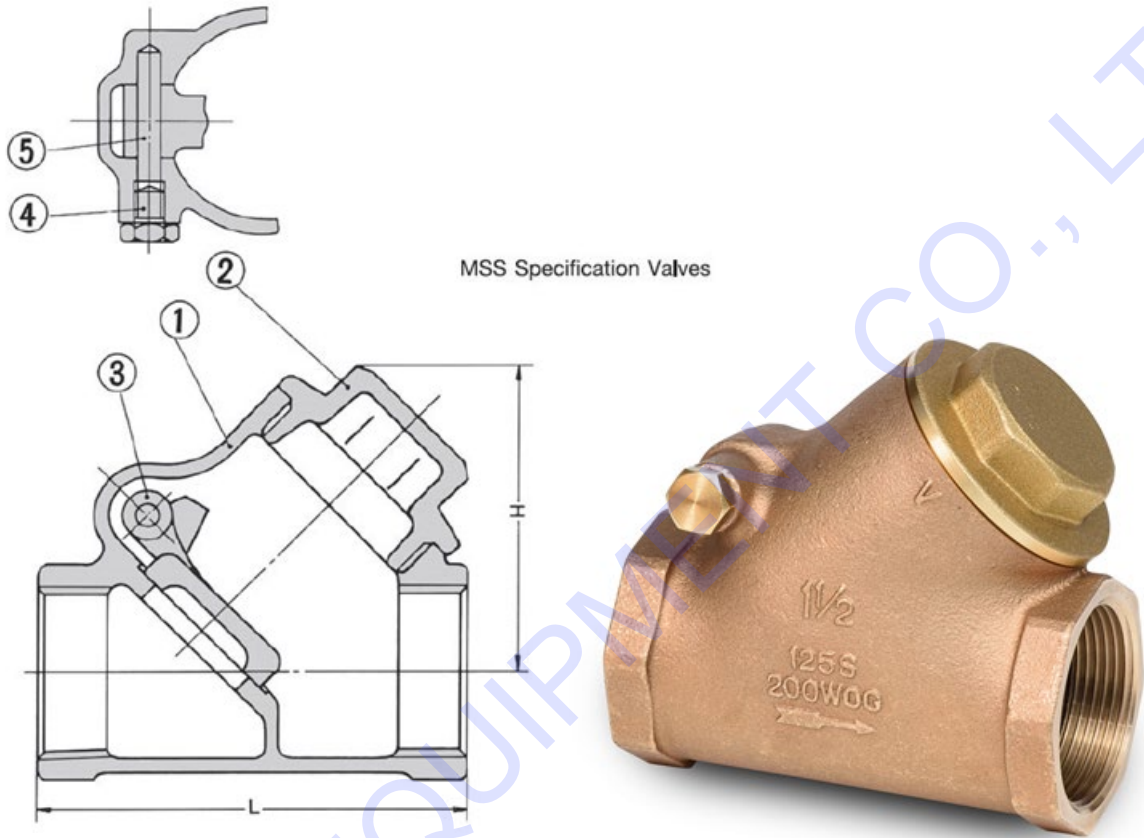

### Material

No.	Name of parts	ASTM Specification	
1	Body	Cast bronze	B62-C83600
2	Cap	Cast bronze	B62-C83600
3	Disc	Cast bronze	B62-C83600
4	Plug	Brass rod	B16-C36000
5	Hanger pin	Copper alloy rod*	B21-C37940

\*Resist Dezincification Material (Toyo copper alloy Pat. No. 845351)

### Dimension

Size Mark		¼	3/8	½	¾	1	1 ¼	1 ½	2	2 ½	3	4
	L	in.	2.20	2.20	2.20	2.76	3.15	3.78	4.33	5.04	6.14	7.24
mm.		56	56	56	70	80	96	110	128	156	184	232
H	in.	1.65	1.65	1.65	1.97	2.28	2.72	3.19	3.86	4.69	5.47	6.85
	mm.	42	42	42	50	58	69	81	98	119	139	174

## Weight

lbs	0.46	0.44	0.57	0.95	1.34	2.11	3.08	4.99	8.71	12.50	24.16
Kgs	0.28	2.27	0.26	0.43	0.61	0.96	1.40	2.27	3.96	5.68	10.98

## Working pressures

Working pressure Non-shock		Test pressure		
Saturated steam	Cold water, Oil, Gas	Shell (Water)	Seat (Air)	
Psig	125	200	300	50
Bar	8.6	13.8	20.7	3.5

- Note :
1. End threads conform to the American, British or Germany standard pipe threads.
  2. These valves conform to the requirements of MSS SP-80.
- \*Design and materials are subject to change without notice.