

Bronze Strainers : Model 380A

Screwed cap, Y-pattern, screwed ends.

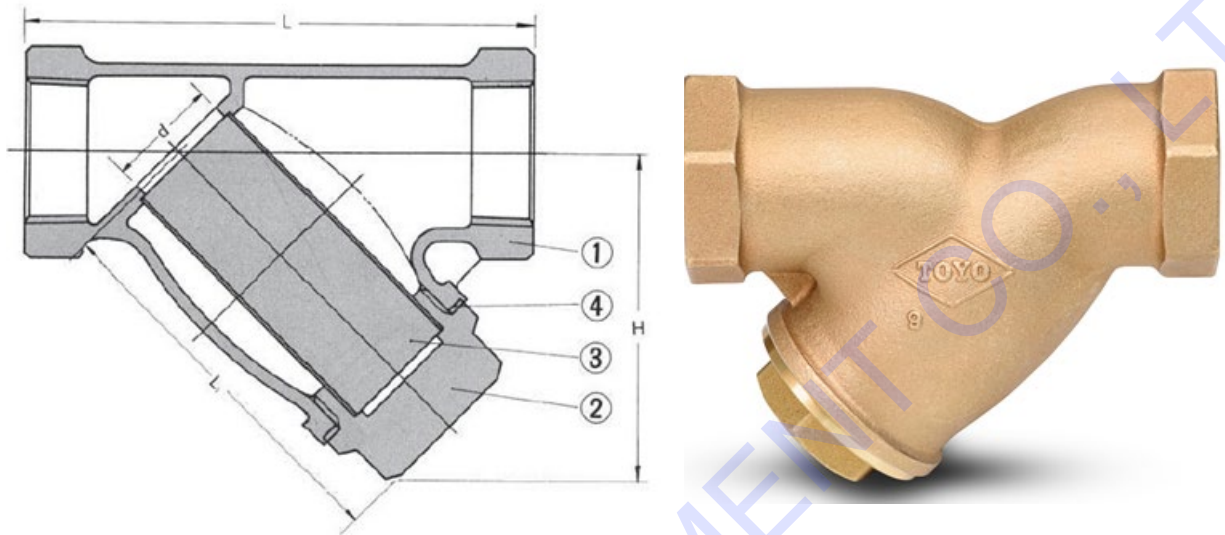

Material

No.	Name of parts	ASTM Specification	
1	Body	Cast Bronze	B62-C83600
2	Cap	Cast Bronze	B62-C83600
3	Screen	Stainless steel	A167-304
4	Gasket	Non-asbestos packing	T#1995
5	O-ring	Buna-N	

Dimension

Mark	Size	½	¾	1	1 ¼	1 ½	2	2 ½	3
L	in.	3.15	3.94	4.53	5.31	6.3	7.68	8.66	9.45
	mm.	80	100	115	135	160	195	220	240
L1	in.	2.36	2.87	3.39	3.9	4.41	5.71	7.05	7.72
	mm.	60	73	86	99	112	145	179	196
H	in.	2.01	2.44	2.91	3.23	3.7	4.76	5.79	6.5
	mm.	51	62	74	82	94	121	147	165
D	in.	0.59	0.79	0.98	1.26	1.57	1.97	2.4	2.99
	mm.	15	20	25	32	40	50	61	76

Data of screen

Data	Size	½	¾	1	1 ¼	1 ½	2	2 ½	3
	Number of holes	in ²	119.4	119.4	119.4	119.4	119.4	119.4	119.4
	cm ²	18.5	18.5	18.5	18.5	18.5	18.5	18.5	18.5
Open area	(%)	32.7	32.7	32.7	32.7	32.7	32.7	32.7	32.7
Total	in ²	3.14	5.12	7.71	11.27	16.32	27.63	42.56	58.33
Screen area	cm ²	20.23	33.00	49.75	72.73	105.26	178.28	274.59	376.29

Weight

lbs	0.64	1.04	1.65	2.71	3.79	6.19	9.61	13.69
Kgs	0.29	0.47	0.75	1.23	1.72	2.81	4.36	6.21

Working pressures

Working pressure Non-shock		Test pressure	
Saturated steam	Cold water, Oil, Gas	Shell (Water)	Seat (Air)
Psig 150	300	450	80
Bar 10.3	20.7	31.0	5.5

Note : 1. End threads conform to the American or British standard pipe threads.
2. Taping for drain plug can be made on the caps of the American standard pipe threads strainers.

*Design and materials are subject to change without notice.