

ประตุน้ำทองเหลือง: Model 204A (ประตุน้ำทองเหลือง คลาส 150 ปอนด์)

ก้านไม่ขยับขึ้นลง, ฝาครอบเกลียว, ลินทองเหลืองตัน, ปลายข้อต่อแบบเกลียว

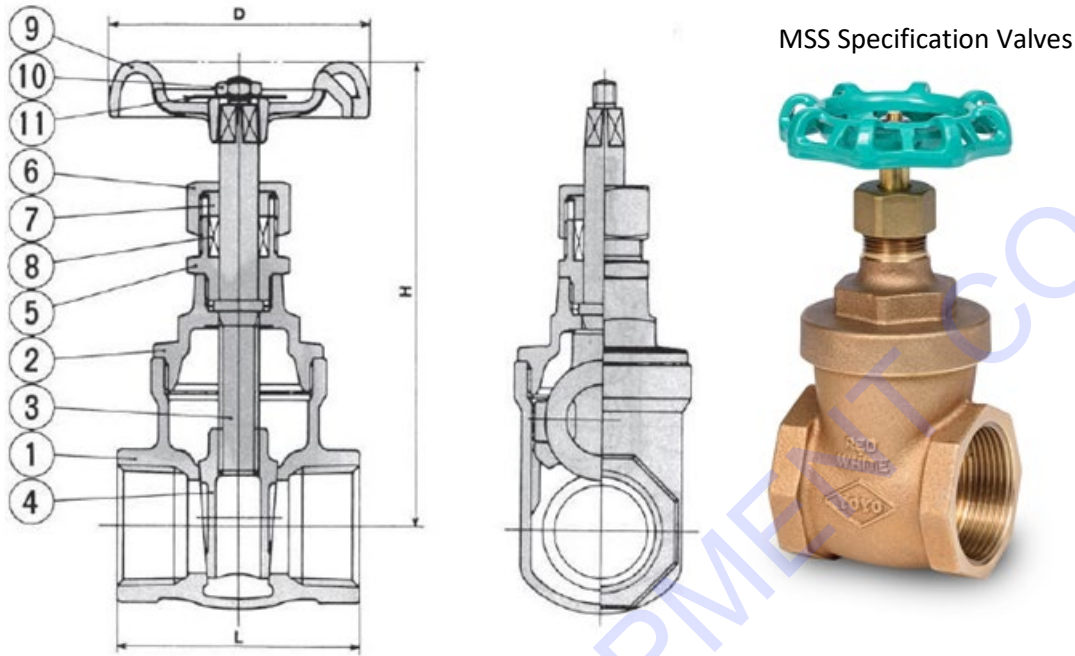

ชิ้นส่วนและชนิดของวัสดุที่ใช้

No.	Name of parts	ASTM Specification	
1	Body	Cast Bronze	B62-C83600
2	Bonnet	Cast Bronze	B62-C83600
3	Stem	Copper alloy rod*	B21-C47940 or
		Or cast bronze (Note 1)	B505-C83600
4	Disc	3/8	Copper alloy rod*
		1/2 - 4	Cast bronze
5	Stuffing box	3/8 - 2 1/2	Brass rod
		3 & 4	Cast bronze
6	Packing nut	3/8 - 2 1/2	Forged brass
		3 & 4	Cast bronze
7	Gland	Forged brass	B124-C37700
8	Gland packing	Non-asbestos packing	T#2996-NA
		3/8 & 1/2	Zinc alloy die casting
9	Handwheel	3/8 - 3	Alluminium alloy die casting
		4	Ductile iron
10	Wheel nut	Steel (Zinc plated)	A563 Gr.A
11	Name plate	Aluminum plate	B209-1100

*Resist Dezincification Material (Toyo copper alloy Pat. No. 845351)

ขนาด

Mark	Size	3/8	1/2	3/4	1	1 ¼	1 ½	2	2 ½	3	4
	L	in.	1.77	1.97	2.20	2.56	2.83	3.11	3.35	4.49	5.12
	mm.	45	50	56	65	72	79	85	114	130	170
H	in.	3.58	3.78	4.33	4.88	5.63	6.46	7.6	9.76	11.06	13.94
	mm.	91	96	110	124	143	164	193	248	281	354
D	in.	1.89	2.17	2.48	2.76	3.15	3.54	3.94	4.92	5.51	7.09
	mm.	48	55	63	70	80	90	100	125	140	180

น้ำหนัก

lbs	0.66	0.86	1.19	2.07	2.54	3.73	5.69	11.29	16.87	36.09
Kgs	0.30	0.39	0.54	0.94	1.15	1.69	2.58	5.12	7.65	16.37

แรงดัน

ใช้งานที่ 300 ปอนด์/ตารางนิ้ว สำหรับ น้ำ, น้ำมัน, แก๊ส

Size	Working pressure Non-shock		Test pressure	
	Saturated steam	Cold water, Oil, Gas	Shell (Water)	Seat (Air)
3/8 to 3	Psig	150	300	450
	Bar	10.3	20.7	31.0
4	Psig	150	225	450
	Bar	10.3	15.5	31.0

Note: 1. Stem materials are as follows:

ASTEM B21-C47940 applied to British standard pipe threaded valves.

ASTEM B505-C83600 applied to American standard pipe threaded valves.

1. End threads conform to the American, British or Germany standard pipe threads.
2. These valves conform to the requirements of MSS SP-80.

*Design and materials are subject to change without notice.