

## PVC-uH Check Valve Model: CVE, EPDM O-rings

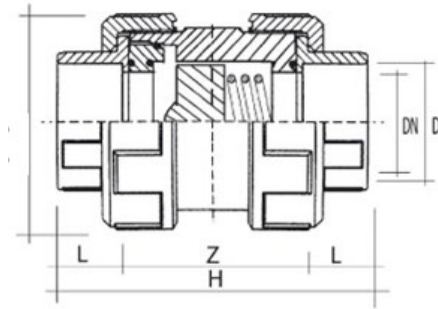

MODEL	DN	L	Z	H	E	Peso g	L/m p=1bar
CERCVE020B	15 (1/2")	16	46	78	50	110	190
CERCVE025C	20 (3/4")	19	52	90	60	180	380
CERCVE032D	25 (1")	22	60	104	68	250	700
CERCVE040E	32 (1 1/4")	24	68	116	80	380	1000
CERCVE050F	40 (1 1/2")	24	78	126	94	600	1700
CERCVE063G	50 (2")	28	93	149	115	1000	3200
CERCVE075H	65 (2 1/2")	33	139	205	168	2800	5000
CERCVE090I	80 (3")	36	139	212	168	3000	7000
CERCVE110L	100 (4")	42	160	244	210	5000	10000

## PVC -uH check valves – "CV" range

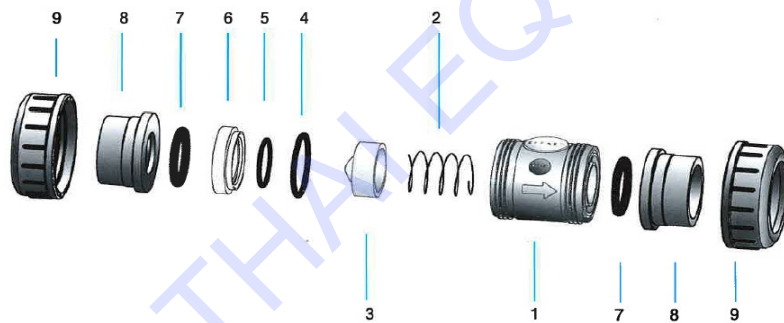

### No. Part

- 1 Body
- 2 Spring
- 3 Swivel Plug
- 4 Body O-ring
- 5 O-ring
- 6 Support
- 7 O-Ring under Sockets
- 8 Sockets
- 9 Nuts