

## ประตูน้ำทองเหลือง: Model 206A (ประตูน้ำทองเหลือง คลาส 125 )

ก้านไม่ขยับขึ้นลง, ฝาเกลียวครอบตัวบอดี้, ลิ้นทองเหลืองตัน, ปลายข้อต่อแบบเกลียว

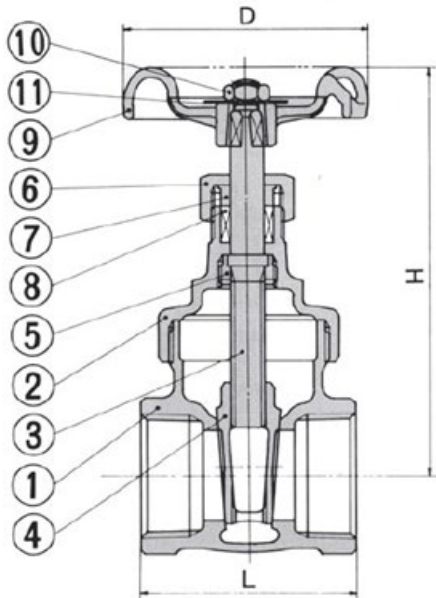

### ชิ้นส่วนและชนิดของวัสดุที่ใช้

No.	Name of parts	ASTM Specification	
1	Body	Cast Bronze B62-C83600	
2	Bonnet	Cast Bronze B62-C83600	
3	Stem	Copper alloy rod* B21-C47940	
4	Disc	Cast Bronze B62-C82600	
5	Lock nut	Copper alloy rod* B21-C47940	
6	Packing nut	¼ - 3	Forged brass B21-C37700
		4	Cast bronze B62-C83600
7	Gland	Forged brass B124-C37700	
8	Gland packing	Non-asbestos packing T#2996-NA	
9	Handwheel	¼ - ¾	Zinc alloy die casting B86-Z335520
		1 - 4	Aluminium alloy die casting B85-A03840
10	Wheel nut	Steel (Zinc plated) A307 Gr. A	
11	Nameplate	Aluminum plate B209-1100	

\*Resist Dezincification Material (Toyo copper alloy Pat. No. 845351)

### ขนาด

Mark	Size	1/4	3/8	1/2	3/4	1	1 ¼	1 ½	2	2 ½	3	4
	L	in.	1.65	1.65	1.73	1.93	2.20	2.40	2.60	2.87	3.54	3.94
	mm.	42	42	44	49	56	61	66	73	90	100	140
H	in.	3.03	3.03	3.19	3.7	4.25	4.92	5.43	6.65	8.07	9.57	12.24
	mm.	77	77	81	94	108	125	138	169	205	243	311
D	in.	1.89	1.89	1.89	2.17	2.48	2.76	3.15	3.54	3.94	4.92	6.30

	mm.	48	48	48	55	63	70	80	90	100	125	160
--	-----	----	----	----	----	----	----	----	----	-----	-----	-----

### น้ำหนัก

lbs	0.57	0.55	0.64	0.88	1.28	1.81	2.51	3.95	7.32	10.71	25.07
Kgs	0.26	0.25	0.29	0.40	0.58	0.82	1.14	1.79	3.32	4.86	11.37

### แรงดัน

ใช้งานที่ 200 ปอนด์/ตารางนิ้ว สำหรับ น้ำ, น้ำมัน, แก๊ส

Working pressure Non-shock		Test pressure	
Saturated steam	Cold water, Oil, Gas	Shell (Water)	Seat (Air)
Psig 125	200	300	80
Bar 8.6	13.8	20.7	5.5

Note: -End threads conform to the American, British or Germany standard pipe threads.  
 -Design and materials are subject to change without notice.