

ประตูน้ำทองเหลือง : Model 275P (ประตูน้ำทองเหลือง คลาส PN16)

ก้านไม่ขยับขึ้นลง, ฝาครอบเกลียว, ลิ้นทองเหลืองตัน, ปลายข้อต่อแบบเกลียว

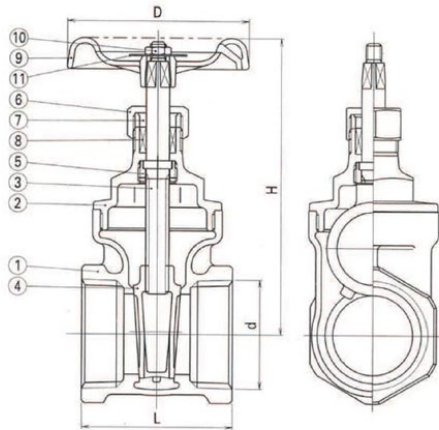

ชิ้นส่วนและชนิดของวัสดุที่ใช้

No.	Name of parts	ASTM Specification	
1	Body	Cast Bronze	B584-C84400
2	Bonnet	Cast Bronze	B584-C84400
3	Stem	Forged brass	C3531
4	Disc	Cast Bronze	B584-C84400
5	Lock nut	Forged brass	B124-C37700
6	Packingnut	Forged brass	B238-C37700
7	Gland	Forged brass	C3604BD
8	Gland packing	Non-asbestos packing	T#2996-NA
9	Handwheel	1/4 - 3/4	Zinc alloy die casting B86-Z335520
		1 - 4	Aluminium alloy die casting B85-A03840
10	Wheel nut	Steel (Zinc plated)	A563 Gr.A
11	Name plate	Aluminium plate	B209-1100

ขนาด

Mark	Size	1/4	3/8	1/2	3/4	1	1 1/4	1 1/2	2	2 1/2	3
	L	in.	1.57	1.57	1.69	1.89	2.08	2.36	2.48	2.79	3.42
mm.		40	43	43	48	53	60	63	71	87	96
H	in.	2.91	2.91	3.03	3.42	3.93	4.60	5.03	5.97	7.07	8.21
	mm.	76	76	76	85	97	117	128	155	180	211
D	in.	1.89	1.89	1.89	2.16	2.48	2.75	2.75	3.14	3.54	3.93
	mm.	48	48	48	55	63	70	70	80	90	100

น้ำหนัก

lbs	0.44	0.51	0.55	0.75	0.99	1.56	1.98	3.01	8.34	11.88
Kgs	0.20	0.23	0.25	0.34	0.45	0.71	0.90	1.37	3.79	5.40

แรงดัน

ใช้งานที่ 232 ปอนด์/ตารางนิ้ว สำหรับ น้ำ, น้ำมัน, แก๊ส

Working pressure Non-shock		Test pressure	
Saturated steam	Cold water, Oil, Gas	Shell (Water)	Seat (Air)
Psig	125	232	348
Bar	8.6	16	24

Note: -End threads conform to the American, British or Germany standard pipe threads.
-Design and materials are subject to change without notice.