

THERMOSTATIC AIR VENT FOR STEAM

Model: LA21

Features

Compact all stainless steel air vent with "fail open" feature for steam, for vertical installation.

1. Vents air automatically until close-to-steam temperature.
2. Compact yet with high capacity.
3. Reacts immediately to changes in operating conditions.
4. Withstands superheat and waterhammer.
5. Easy to maintain and easy to clean.
6. Hardened stainless steel valve seat.
7. Tight shut-off.



Specifications

Model	LA21
Connection	Screwed
Size (mm)	15
Max. Operating Press. (MPaG) PMO	2.1
Min. Operating Press. (MPaG)	0.01
Max. Operating Temp. (°C) TMO	See graph at right
Subcooling of X-element Fill (°C)	Up to 22
Type of X-element	T

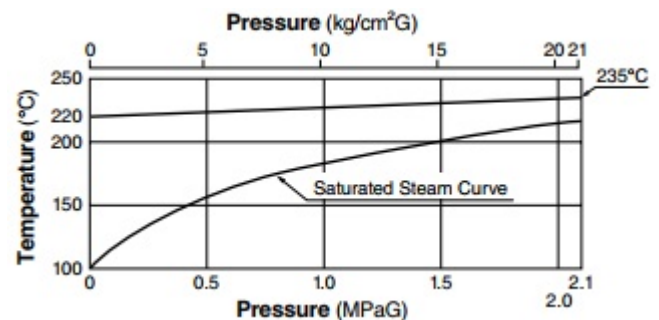

PRESSURE SHELL DESIGN CONDITIONS (NOT OPERATING CONDITIONS):

1MPa = 10.197 kg/cm²

Maximum Allowable Pressure (MPaG) : 6.3

Maximum Allowable Temperature (°C) : 425

CAUTION : To avoid abnormal operation, accidents of serious injury, Do Not use this product outside of the specification range. Local regulations may restrict the use of this product to below the conditions quoted.

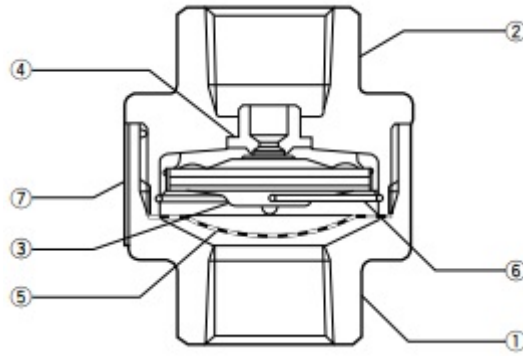

No.	Description	Materials	JIS	ASTM/AISI*
1	Body Lower Part	Cast Stainless Steel	SCS13A	A351 Gr. CF-8
2	Body Upper Part	Cast Stainless Steel	SCS13A	A351 Gr. CF-8
3	X-element	Stainless Steel	-	-
4	Valve Seat	Stainless Steel	SUS630	AISI630
5	Screen	Stainless Steel	SUS304	AISI304
6	Spring Clip	Stainless Steel	SUS304	AISI304
7	Nameplate	Stainless Steel	SUS304	AISI304

*Equivalent

Dimensions

LA21 Screwed* (mm)

Size	L	ϕW	Weight (kg)
15	55	47	0.4

*Rc(PT), other standards available

