

## ปัตเตอร์ฟลายวาล์ว แบบมือหมุน : Model 550GA

ออกแบบตามมาตรฐาน JIS B2032 และ ISO5752 คุณสมบัติพิเศษกันการกัดตัวของหยดน้ำ, พื้นที่หุ้มฉนวนช่วงคอกอย่างน้อย 62 mm, มีน้ำหนักเบา, ลึนเป็นสแตนเลส 316, ยาง EPDM กันรั่วซึม, ก้านสเต็มเป็นสแตนเลส 403, ด้ามควบคุมเป็นพื้นเฟืองตัวหนอน

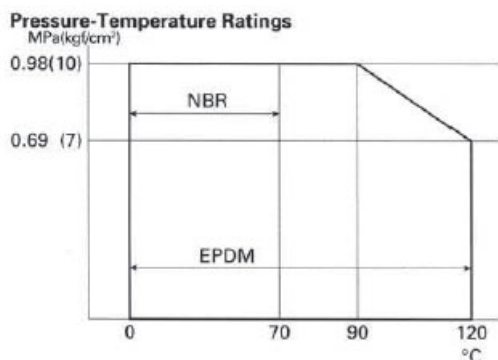

### แรงดัน

ใช้งานที่ 150 ปอนด์ต่อตารางนิ้ว

Working pressure Non-shock	Hydrostatic test pressure	
	Shell	Seat
MPa 0.98	1.5	1.1
Kgf/cm <sup>2</sup> 10	1.5	1.1

### ชิ้นส่วนและวัสดุที่ใช้

No.	Name of parts		ASTM Specification	
1	Body	40 - 200	Aluminum alloy	B85-SC102A
		250 & 300		A351-CF8M
2	Disc		Stainless steel	
3	Rubber liner		EPDM	A276-403
4	Upper stem		Stainless steel	A276-403
5	Lower stem		Stainless steel	A351-CF8
6	Yoke		Stainless steel	
7	Oring	40- 200	EPDM	B85-SC102A
8	Plug	40 - 200	Aluminum alloy	
9	Bottom cover	250 & 300	Steel	
10	Bottom gasket	250 & 300	Non-asbestos packing	
11	Oring		NBR	
12	Gear unit			

### ค่าสัมประสิทธิ์การไหล

MM.

Size	Full opening
2	220
2 ½	420
3	630
4	990
5	1500
6	1940
8	4200
10	6800
12	7600

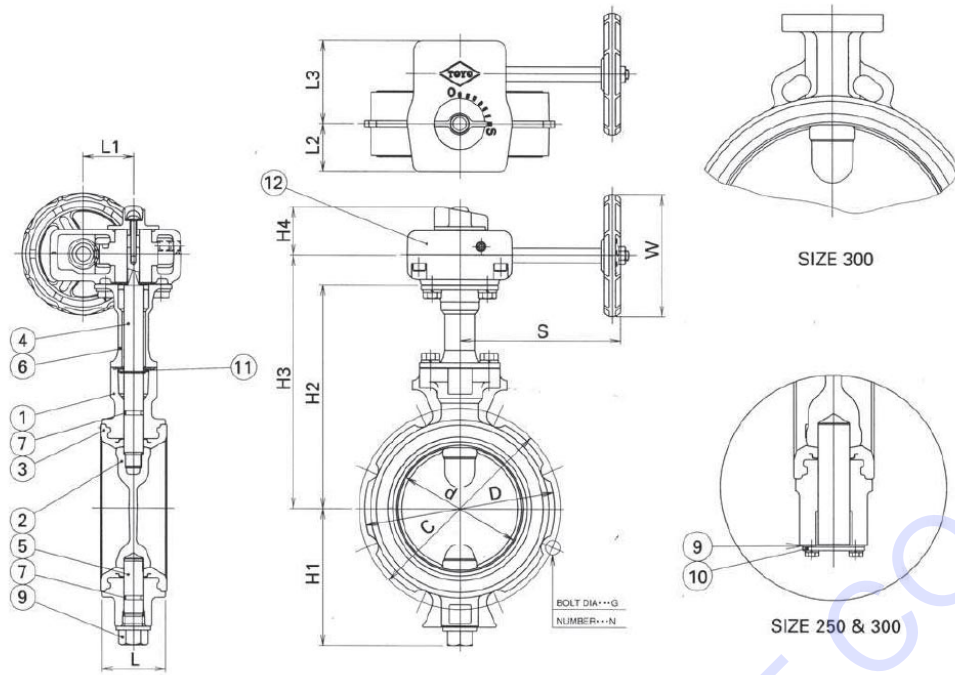

**Note :**

1. End connections conform to JIS 10K and ANSI B 16.1 class 125 cast iron flanges, flat and smooth face.
2. Face to face dimensions are according to JIS B 2032 and ISO-5752.

**ขนาด**

Mark Size (in)	Mark (mm)	d	L	H1	H2	H3	H4	JIS 10K Flange				L1	L2	L3	S	W	Gear unit	Weight	
								C	D	N	G							lb	kg.
1 - 1/2	40	42	33	70	145	168	30	105	86	4	M16	34	30	52	131	100	G-00A	4.0	1.8
2	50	52	43	82	145	168	30	120	101	4	M16	34	30	52	131	100	G-00A	4.6	2.1
2 - 1/2	65	67	46	90	157	180	30	140	121	4	M16	34	30	52	131	100	G-00A	5.5	2.5
3	80	80	46	99	165	188	30	150	131	8	M16	34	30	52	131	100	G-00A	6.0	2.7
4	100	102	52	112	183	206	30	175	156	8	M16	34	30	52	131	100	G-00A	6.4	2.9
5	125	126	56	132	196	220	35	210	187	8	M20	41	39	67	132	100	G-01A	11.0	5.0
6	150	150	56	146	214	238	35	240	217	8	M20	41	39	67	132	100	G-01A	14.6	6.6
8	200	199	60	188	241	272	41	290	267	12	M20	58	48	89	149	140	G-02A	21.2	9.6
10	250	248	68	220	320	367	57	355	324	12	M22	67	61	97	178	200	G-3A	47.4	21.5
12	300	297	78	255	355	402	57	400	367	12	M22	67	61	97	178	200	G-4A	68.3	31.0

**ค่าความดัน-อุณหภูมิ**

**A) Bronze and Brass valves (Extracted from MSS SP-80)**

Service temperature			100		125		150		200		300				
			THD				FLG		THD						
°C	°F	MPa	psi	MPa	psi	MPa	psi	MPa	psi	MPa	psi	MPa	psi	MPa	psi
-29 -66	-20 -150	1.03	150	1.37	200	2.06	300	1.55	225	2.75	400	4.13	600	6.89	1000
93	200	0.93	136	1.27	185	1.86	270	1.44	210	2.58	375	3.86	560	6.34	920
121	250	0.86	126	1.17	170	1.65	240	1.34	195	2.41	350	3.61	525	5.72	830
149	300	0.79	116	1.06	155	1.44	210	1.24	180	2.24	325	3.37	490	5.10	740
177	350	0.68	100	0.96	140	1.24	180	1.13	165	2.06	300	3.10	450	4.48	650
204	400	0.63	92	-	-	-	-	-	-	1.89	275	2.82	410	3.86	560
208	406	0.62	90	0.86	125	1.03	150	1.03	150	-	-	-	-	-	-
232	450	-	-	-	-	-	-	-	-	1.72	250	2.58	375	3.30	480
260	500	-	-	-	-	-	-	-	-	1.55	225	2.34	340	2.68	390
288	550	-	-	-	-	-	-	-	-	1.37	200	2.06	300	2.06	300
Saturated steam		0.68	100	0.86	125	1.03	150	1.03	150	1.37	200	2.06	300	2.06	300
Test Pressure	shell	1.55	225	2.06	300	3.10	450	2.41	350	4.13	600	6.20	900	10.34	1500
	water seat	0.55	80	0.55	80	0.55	80	0.55	80	0.55	80	0.55	80	0.55	80
	air	0.55	80	0.55	80	0.55	80	0.55	80	0.55	80	0.55	80	0.55	80

Note : Class100 outside of MSS SP-80

## B) Cast Iron Valves (Extracted from MSS SP-70, 71 & 85)

Class 125 Gate, Globe and Check Valves

Temperature			Size 50 thru 300		Above size 350	
°C	°F		MPa	psi	MPa	psi
-29 -66	-20 -150		1.37	200	1.03	150
93	200		1.31	190	0.93	135
107	225		1.24	180	0.90	130
121	250		1.21	175	0.86	125
135	275		1.17	170	0.83	120
149	300		1.14	165	0.76	110
163	325		1.07	155	0.72	105
178	350		1.03	150	0.69	100
191	375		1.00	145		
208	400		0.97	140		
218	425		0.90	130		
232	450		0.86	125		
Saturated steam			0.86	125	0.68	100
Test	shell	Water	2.41	350	1.83	265
Pressure	seat	air	0.55	80	0.55	80

## C) 10K Cast Iron Ball Valves

